



MALOSSSI

UNIVERS

2017



5898B	Ø 134	5579B	715579B	5216202	5216202	2913137	2913137
MAXI WING CLUTCH		149,00	149,00	149,94	149,94	20,99	20,99
CAMPANA + FRIZIONE (A)							
MAXI FLY SYSTEM							
CAMPANA + FRIZIONE NON REGOLABILE							
MAXI DELTA SYSTEM	16918						
CAMPANA + FRIZIONE REGOLABILE	56,00	Ø 134					
CLUTCH							

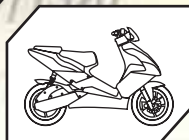
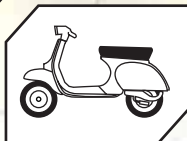
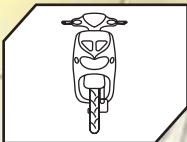
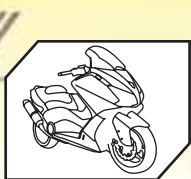

INDEX



EXPLODED VIEW OF VEHICLES

BMW 600 - 650 SPORT	28
GILERA RUNNER SP TROFEI MALOSSI	302
HONDA FORZA ABS 125 ie	30
HONDA NSC 50 4T	4
HONDA SH I ABS 125 - 150 2013->	32
HONDA SH I 125 - 150 2009->2012	34
HONDA SH I 300	36
KAWASAKI J 300	38
KYMC0 DOWNTOWN 350	40
KYMC0 XCITING 400	42
PIAGGIO APE 50	413
PIAGGIO CIAO	400
PIAGGIO TYPHOON 125 4T LC - PROTOTIPO MALOSSI	26
PIAGGIO ZIP SP TROFEI MALOSSI	298
VESPA GTS SUPER 125 4T	44
VESPA 3V PRIMAVERA 125 - 150 4T	46
YAMAHA AEROX 50 TROFEI MALOSSI	300
YAMAHA T-MAX 500	48
YAMAHA T-MAX 530	52



TABLES BRAND / MODEL

ATV QUAD	388
AUTOMATIC MOTORCYCLES	406
MOTORCYCLES MBK - PEUGEOT	398
MOTORCYCLES PIAGGIO	404
DIGITRONIC K.R.M. electronic coil	286
MAXI SCOOTER 125 → 800 4T	58
MAXI SCOOTER 2T	290
MOTO 50	364
MOTO 50 - 80 OLD	392
MOTO 125 - 135 4T	380
PIAGGIO APE 50	412
PIT BIKE	397
SCOOTER SPORT 50 → 124 4T	6
SCOOTER 2T	198
SCOOTER 2T MHR	304
VESPA GEARS	408



C-ONE / RC-ONE

C-ONE PIAGGIO	342
C-ONE YAMAHA	345
RC-ONE PIAGGIO	348
RC-ONE YAMAHA	352
AIR FORCE	356
CYLINDER KIT FLANGED MOUNT	358
GORILLA ARM	360
C-ONE PIAGGIO - YAMAHA	362
RC-ONE PIAGGIO - YAMAHA	363



CIRCULARES TECNICAS

TECHNICALCIRCULAR N° 1/2015	416
TECHNICALCIRCULAR N° 2/2015	414



SECTIONALS

AIR FILTER - E18 / E19	480
BEARINGS	473
BELTS	452
CLUTCH SYSTEM	464
DRR	386
EXHAUST SYSTEM MAXI SCOOTER	418
EXHAUST SYSTEM SCOOTER - MOTO 50	424
GEARS	478
GRIPS	506
HEAT MASTER - ENERGY PUMP	422
HELMETS	504
LUBRICANTS	490
MULTIVAR HOMOLOGATED	436
NEEDLE ROLLER BEARINGS	472
OIL-SEAL	476
PINWHEEL SHAFT	487
POWER TRANSMISSION	489
ROLLER CRANKCASE	486
ROLLERS VARIATOR	463
SCREENS	498
SHOCK ABSORBERS	482
SOUNDPROOF ELEMENT	435
SPARK PLUGS	504
SPRINGS MAXI SCOOTER	445
SPRINGS SCOOTER 50 > 110	438

SPECIFICATIONS EXAMPLE :

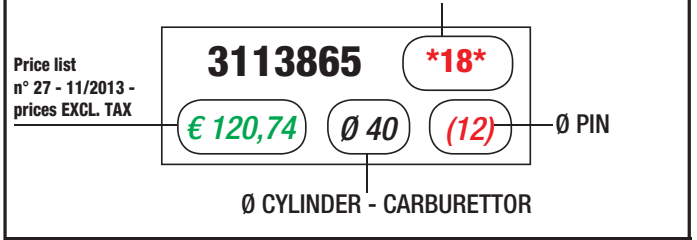

<-2000 = up to 2000

2001-> = from 2001

1 ATTENTION: For scooter - Quad 50

If you want to assemble Malossi crankshaft (pin Ø 12) with this cylinder-head (pin Ø 10), it is absolutely necessary to substitute the piston included in the cylinder with the one indicated in the following table (pin Ø 12) :

CYLINDER+HEAD	CRANKSHAFT	PISTON to be USED	0 / sel		magg
			pin Ø 10	pin Ø 12	
31 6170	53 8123	34 7036	(•) € 41,72	€ 46,10	
31 6901	53 8008	34 8538	(•) € 54,71	€ 56,98	
31 7083	53 8009	34 7036	(•) € 41,72	€ 46,10	
31 7237	53 8008	34 7036	(•) € 41,72	€ 46,10	
31 7559	53 8008	34 7849	(•) € 54,88	€ 62,09	
31 8284	53 8009	34 7036	(•) € 41,72	€ 46,10	
31 8403	53 8009	34 8544	€ 49,03		
31 8430	53 8009	34 7849	(•) € 54,88	€ 62,09	
31 8437	53 8009	34 7849	(•) € 54,88	€ 62,09	
31 8501	53 8008	34 7849	(•) € 54,88	€ 62,09	
31 8556	53 8009	34 8538	(•) € 54,71	€ 56,98	
31 8559	53 8009	34 8544	€ 49,03		
31 8562	53 8009	34 8538	(•) € 54,71	€ 56,98	
31 8565	53 8008	34 8544	€ 49,03		

(•) with 2 piston rings

Malossi reserves the right to make technical and code modifications as well as to the quantity of multiple packages whenever it is considered necessary, and shall not accept liability for any typographic or printing errors.

NEW LOGO MALOSSI



We are proud to officially present our **new company logo** the result of a year of work dedicated to the restyling of our brand image which has always contained the fundamental elements of Malossi's DNA: **energy, modernity, passion** and **Italian style**.

These values, Michele Enko Costa explains, have inspired the methods used during the restyling.

"The new font, spacing and its equilibrium were my starting point when making structural improvements. Creating a new brand which expresses the determination and experience of a historic company had to be my objective. Designing new lines, using new colours, creating a unique symbol, whilst maintaining the fundamental characteristics of a legendary marque."

In deciding the final logotype, Malossi's strong personality was analysed in full, **as an source of great interest for observers and enthusiasts of the sector from 1980 to 2015**.

By studying in depth the evolution of the company image with the intention of conveying the same passion that the company uses in its daily work has produced a final result which is a perfect compromise between modernity and tradition.

Our lion, a symbol of courage and nobility, strength and caution, reappears in a new setting, whilst retaining the principles which led to the choice of this symbol in the first place.

"Decisive and winding lines, Enko explains, are a complete re-design of the new figure - giving a determined and contemporary image, and moving away from the classic iconography used up until now"

The Malossi Lion has been renewed, and is full of passion and modernity.

Our company and our roots haven't changed: and nor has our vision for the future!

And the story continues...

The brand's experience and determination are key to its restyling.

youtu.be/XrupduFA26o

MALOSSI LOGOTYPE_1980



MALOSSI LOGOTYPE_1990

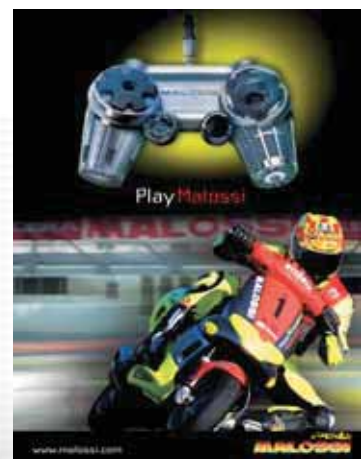

MALOSSI LOGOTYPE_2015





**Aluminium
complete cylinder
Ø 49 pin Ø 10
I-TECH 4 Stroke
3116518
€ 404,00**

New

**EXHAUST SYSTEM RX
homologated**

New

**X K BELT
6116671
€ 29,00**



**Honda
50**

MULTIVAR 2000

5115209

€ 58,71



DELTA CLUTCH

52 7880

€ 77,89

New



FLY CLUTCH
NOT adjustable
automatic clutch

52 8797

€ 47,80



la NSC
4T



**TC UNIT O2 controller -
lambda emulator**

5516458

€ 89,00



MALOSSI

Scooter Sport

50 → 124 4T

with ENGINE 

APRILIA

SCARABEO

SCARABEO 4V
euro 2

SCARABEO

SPORTCITY ONE

(PIAGGIO C373M)

(PIAGGIO C377M)

50 4T



50 4T



100 4T



50 4T



	CYLINDER 4 STROKE ALUMINIUM	3113905 € 204,00 Ø 49	3113905 € 204,00 Ø 49	-	3113905 € 204,00 Ø 49
	CYLINDER I-TECH ALUMINIUM EQUIPPED WITH CDI	-	-	-	-
	POWER CAM CAMSHAFT	*63*	*60*	-	*63*
	DIGITRONIC COIL VARIABLE ADVANCE	-	5514396 € 149,50	-	-
	TC UNIT 02 controller LAMBDA EMULATOR	-	-	-	-
	MULTIVAR VARIATOR	5111597 € 61,80	5111597 € 61,80	5112024 € 60,00	5111597 € 61,80
	X SPECIAL BELT BELT	61 9831 € 19,49	61 9831 € 19,49	-	61 9831 € 19,49
	X K BELT BELT	6113191 € 25,34	6113191 € 25,34	6113191 € 25,34	6113191 € 25,34
	HTRoll ROLLERS FOR MULTIVAR 2000	66 9420.G0 € 10,00 gr.06,1	66 9420.G0 € 10,00 gr.06,1	66 9420.10 € 10,00 gr.10	66 9420.G0 € 10,00 gr.06,1
	HTRoll ROLLERS FOR ORIGINAL VARIATOR	66 9420.I0 € 10,00 gr.06,5	66 9420.I0 € 10,00 gr.06,5	-	66 9420.I0 € 10,00 gr.06,5
	VARIABLE-SPEED DRIVE ADJUSTER SPRING FOR ORIGINAL VARIATOR	PG. 438 PG.438	PG.438	-	PG.438
	TORSION CONTROLLER ANTIFRICTION	-	-	-	-
	TORQUE DRIVER MOBILE DRIVEN SPLIT PULLEY	61 9100 € 85,57	61 9100 € 85,57	-	61 9100 € 85,57
	FLY CLUTCH / MAXI FLY CLUTCH NOT ADJUSTABLE CLUTCH	52 8797 € 47,30	52 8797 € 47,30	-	52 8797 € 47,30
	DELTA CLUTCH / MAXI DELTA CLUTCH ADJUSTABLE CLUTCH	52 7880 € 77,89	52 7880 € 77,89	-	52 7880 € 77,89
	FLY SYSTEM CLUTCH BELL + NOT ADJUSTABLE CLUTCH	5214111 € 63,00 Ø 107	5214111 € 63,00 Ø 107	-	5214111 € 63,00 Ø 107
	DELTA SYSTEM / MAXI DELTA SYSTEM CLUTCH BELL + ADJUSTABLE CLUTCH	5214110 € 93,84 Ø 107	5214110 € 93,84 Ø 107	-	5214110 € 93,84 Ø 107
	DELTA SYSTEM MHR CLUTCH BELL + ADJUSTABLE CLUTCH	5214738 € 156,00 Ø 107	5214738 € 156,00 Ø 107	-	5214738 € 156,00 Ø 107
	CLUTCH BELL CLUTCH BELL (SMOOTH RING)	7711115 € 22,60 Ø 107	7711115 € 22,60 Ø 107	-	7711115 € 22,60 Ø 107
	WING CLUTCH BELL / MAXI WING CLUTCH BELL (FINNED RING)	7711207 € 33,45 Ø 107	7711207 € 33,45 Ø 107	-	7711207 € 33,45 Ø 107
	WING CLUTCH BELL MHR CLUTCH BELL (FINNED RING)	7714147 € 90,00 Ø 107	7714147 € 90,00 Ø 107	-	7714147 € 90,00 Ø 107

60 - TO COUPLE ONLY with MALOSSİ CYLINDERS : 5914211 € 116,39

61 - TO COUPLE ONLY with MALOSSİ CYLINDERS : 5914143 € 178,00

63 - TO COUPLE ONLY with MALOSSİ CYLINDERS : 5911988 € 110,73

BAOTIAN		GARELLI				HONDA		
ECO BIKE	REBEL - ROCKY - TANCO 9/12	FLEXI' euro 2	TIESSE FOUR euro 2	VIP	DIO Clean 4 You	NSC50R ie euro 2	RUCKUS	
(139 QMB)		(1P139 QMB)	(1P39QMB)	(139 QMA)		(AF72E)		
50 4T	50 4T	50 4T	50 4T	50 4T	50 4T	50 4T	50 4T	
					LC		LC	
3113243 €214,14 Ø 52	3113243 €214,14 Ø 52	3113243 €214,14 Ø 52	3113243 €214,14 Ø 52	-	-	-	-	
-	-	-	-	-	-	3116518 €404,00 Ø 49	-	
61	*61*	*61*	*61*	-	-	-	-	
-	-	-	-	-	-	-	-	
-	-	-	-	-	-	5516458 €89,00	-	
5113139 €58,71	5113139 €58,71	5113139 €58,71	5113139 €58,71	5113424 €58,71	5111852 €60,17	5115209 €58,71	5111852 €60,17	
-	-	-	-	61 9832 €17,04	-	-	-	
6113397 €22,44	-	6113501 €20,40	6113501 €20,40	61 7587 €28,25	-	6116671 €29,00	-	
66 9823.M0 €9,50 gr.07	66 9823.M0 €9,50 gr.07	66 9823.M0 €9,50 gr.07	66 9823.M0 €9,50 gr.07	66 9823.L0 €9,50 gr.06	66 9823.L0 €9,50 gr.06	66 9823.Q0 €9,50 gr.07,5	-	
66 9823.L0 €9,50 gr.06	66 9823.L0 €9,50 gr.06	66 9823.I0 €9,50 gr.05,1	66 9823.L0 €9,50 gr.06	-	66 9823.L0 €9,50 gr.06	66 9823.M0 €9,50 gr.07	66 9823.L0 €9,50 gr.06	
PG.438	PG.438	PG.438	PG.438	PG.438	-	PG.438	-	
-	-	-	-	-	2512828 €4,45	-	2512828 €4,45	
61 8317 €95,61	61 8317 €95,61	61 8317 €95,61	61 8317 €95,61	61 8317 €95,61	-	-	-	
52 8797 €47,30	52 8797 €47,30	52 8797 €47,30	52 8797 €47,30	52 8797 €47,30	-	52 8797 €47,30	-	
52 7880 €77,89	52 7880 €77,89	52 7880 €77,89	52 7880 €77,89	52 7880 €77,89	-	52 7880 €77,89	-	
5214111 €63,00 Ø 107	5214111 €63,00 Ø 107	5214111 €63,00 Ø 107	5214111 €63,00 Ø 107	-	-	-	-	
5214110 €93,84 Ø 107	5214110 €93,84 Ø 107	5214110 €93,84 Ø 107	5214110 €93,84 Ø 107	-	-	-	-	
5214738 €156,00 Ø 107	5214738 €156,00 Ø 107	5214738 €156,00 Ø 107	5214738 €156,00 Ø 107	-	-	-	-	
7711115 €22,60 Ø 107	7711115 €22,60 Ø 107	7711115 €22,60 Ø 107	7711115 €22,60 Ø 107	-	-	-	-	
7711207 €33,45 Ø 107	7711207 €33,45 Ø 107	7711207 €33,45 Ø 107	7711207 €33,45 Ø 107	-	-	-	-	
7714147 €90,00 Ø 107	7714147 €90,00 Ø 107	7714147 €90,00 Ø 107	7714147 €90,00 Ø 107	-	-	-	-	



MALOSSI

Scooter Sport

50 → 124 4T

with ENGINE 

APRILIA

SCARABEO

SCARABEO 4V
euro 2

SCARABEO

SPORTCITY ONE

(PIAGGIO C373M)

(PIAGGIO C377M)

50 4T



50 4T



100 4T









50 4T



	SPORT SPRINGS FOR FLY / DELTA CLUTCH	29 8746 € 14,50	29 8746 € 14,50	-	29 8746 € 14,50
	MHR SPRINGS FOR FLY / DELTA CLUTCH	29 8747 € 19,40	29 8747 € 19,40	-	29 8747 € 19,40
	SPRINGS FOR ORIGINAL CLUTCH	-	-	-	29 7454 € 16,20
	RED SPONGE FOR ORIGINAL AIR BOX	1416575 € 2,80	1416575 € 2,80	1416575 € 2,80	-
	DOUBLE RED SPONGE FOR ORIGINAL AIR BOX	-	-	-	-
	GEARS HTQ PRIMARY	-	-	-	-
	GEARS HTQ SECONDARY (COUPLING Ø)	6711135 € 58,86 z 15/55 (17)	6711135 € 58,86 z 15/55 (17)	-	6711135 € 58,86 z 15/55 (17)
	PINWHEEL SHAFT	6714530 € 66,30	6714530 € 66,30	-	6714530 € 66,30
	ROLLER CRANKCASE	2514521 *66* € 95,00	2514521 *66* € 95,00	-	2514521 *66* € 95,00
	ROLLER CRANKCASE TEAM	PG. 486 2514603 *66* € 95,00	2514603 *66* € 95,00	-	2514603 *66* € 95,00
	SPORT SCREEN SCREEN	-	-	-	-
	BRAKE PADS FRONT ORGANIC BRAKE PADS	6215042 € 5,72	6215042 € 5,72	-	6215062 € 8,32
	BRAKE PADS MHR FRONT ORGANIC BRAKE PADS	6215080 € 6,00	6215080 € 6,00	-	6215079 € 8,20
	BRAKE PADS MHR SYNT FRONT SINTERED BRAKE PADS	6215007 € 11,96	6215007 € 11,96	-	6215013 € 16,50
	BRAKE POWER REAR BRAKE SHOES	-	-	-	-
	DISC FRONT BRAKE DISCS	-	-	-	-
	WHOOOP DISC FRONT BRAKE DISCS	-	-	-	6212929 € 105,00
	RS3 REAR SHOCK ABSORBER	-	-	-	-
	RS1 REAR SHOCK ABSORBER	-	-	-	-
	RS24 REAR SHOCK ABSORBER	-	-	-	-
	RS24 FRONT SHOCK ABSORBER	-	-	-	-

66 - NOT to be used on VEHICLE WITH ORIGINAL PRIMARY GEARS

PG - SPECIFICATIONS on the PAGE indicated in the TITLE of the LINE

BAOTIAN		GARELLI			HONDA		
ECO BIKE	REBEL - ROCKY - TANCO 9/12	FLEXI' euro 2	TIESSE FOUR euro 2	VIP	DIO Clean 4 You	NSC50R ie euro 2	RUCKUS
(139 QMB)		(1P139 QMB)	(1P39QMB)	(139 QMA)		(AF72E)	
50 4T 	50 4T 	50 4T 	50 4T 	50 4T 	50 4T LC	50 4T 	50 4T LC
29 8746 € 14,50	29 8746 € 14,50	29 8746 € 14,50	29 8746 € 14,50	-	-	-	-
29 8747 € 19,40	29 8747 € 19,40	29 8747 € 19,40	29 8747 € 19,40	-	-	-	-
29 9605 € 16,20	29 9605 € 16,20	29 9605 € 16,20	29 9605 € 16,20	29 9605 € 16,20	-	29 9605 € 16,20	-
-	-	-	-	-	-	-	-
-	-	-	-	-	-	-	-
-	-	-	-	-	-	-	-
-	-	-	-	-	-	-	-
-	-	-	-	-	-	-	-
-	-	-	-	-	-	-	-
-	-	-	-	-	-	-	-
6215044 € 6,97	-	-	-	-	-	-	-
62 9084 € 6,90	-	-	-	-	-	-	-
-	-	-	-	-	-	-	-
-	-	-	-	-	-	-	-
-	-	-	-	-	-	-	-
6214097 € 62,00	-	6212603 € 72,56	6212603 € 72,56	-	-	-	-
-	-	46 7905 € 140,92	-	-	-	-	-
-	-	-	-	-	-	-	-
-	-	46 7588 € 255,97	-	-	-	-	-
-	-	-	-	-	-	-	-





MALOSSI

Scooter Sport

50 → 124 4T

with ENGINE 

HONDA			HUPPER
VISION ie	VISION ie	ZOOMER	MONTECARLO 30
(AF72E)	(JF31E)		(139QMB)
50 4T 	110 4T 	50 4T LC	50 4T 

	CYLINDER 4 STROKE ALUMINIUM	-	-	-	3113243 €214,14 Ø 52
	CYLINDER I-TECH ALUMINIUM EQUIPPED WITH CDI	3116518 €404,00 Ø 49	-	-	-
	POWER CAM CAMSHAFT	-	-	-	*61*
	DIGITRONIC COIL VARIABLE ADVANCE	-	-	-	-
	TC UNIT O2 controller LAMBDA EMULATOR	5516458 €89,00	-	5514750 €84,00	-
	MULTIVAR VARIATOR	5115209 €58,71	5115211 €80,00	5111852 €60,17	5113139 €58,71
	X SPECIAL BELT BELT	-	6116748 €32,00	-	-
	X K BELT BELT	6116671 €29,00	-	-	6113501 €20,40
	HTRoll ROLLERS FOR MULTIVAR 2000	66 9823.Q0 €9,50 gr.07,5	66 9420.K0 €10,00 gr.12	66 9823.L0 €9,50 gr.06	66 9823.M0 €9,50 gr.07
	HTRoll ROLLERS FOR ORIGINAL VARIATOR	66 9823.Q0 €9,50 gr.07,5	-	66 9823.L0 €9,50 gr.06	66 9823.L0 €9,50 gr.06
	VARIABLE-SPEED DRIVE ADJUSTER SPRING FOR ORIGINAL VARIATOR	PG. 438 PG.438	-	-	PG.438
	TORSION CONTROLLER ANTIFRICTION	-	-	-	-
	TORQUE DRIVER MOBILE DRIVEN SPLIT PULLEY	-	-	-	61 8317 €95,61
	FLY CLUTCH / MAXI FLY CLUTCH NOT ADJUSTABLE CLUTCH	52 8797 €47,30	5212522 €70,37	-	52 8797 €47,30
	DELTA CLUTCH / MAXI DELTA CLUTCH ADJUSTABLE CLUTCH	52 7880 €77,89	5212487 €112,59	-	52 7880 €77,89
	FLY SYSTEM CLUTCH BELL + NOT ADJUSTABLE CLUTCH	-	-	-	5214111 €63,00 Ø 107
	DELTA SYSTEM / MAXI DELTA SYSTEM CLUTCH BELL + ADJUSTABLE CLUTCH	-	5216070 €125,46 Ø 125	-	5214110 €93,84 Ø 107
	DELTA SYSTEM MHR CLUTCH BELL + ADJUSTABLE CLUTCH	-	-	-	5214738 €156,00 Ø 107
	CLUTCH BELL CLUTCH BELL (SMOOTH RING)	-	-	-	7711115 €22,60 Ø 107
	WING CLUTCH BELL / MAXI WING CLUTCH BELL (FINNED RING)	-	7713376 €38,00 Ø 125	-	7711207 €33,45 Ø 107
	WING CLUTCH BELL MHR CLUTCH BELL (FINNED RING)	-	-	-	7714147 €90,00 Ø 107

61 - TO COUPLE ONLY with MALOSSİ CYLINDERS : 5914143 € 178,00

63 - TO COUPLE ONLY with MALOSSİ CYLINDERS : 5911988 € 110,73

ITALJET		KYMCO					
TORPEDO	AGILITY R10/12 - RS euro 2	AGILITY R16 - RS euro 2	DINK euro 2	FILLY	LIKE euro 2	PEOPLE euro 2	PEOPLE S euro 2
	(KL10B)	(KL10B)			(KG10A)		(BB10)
50 4T	50 4T	50 4T	50 4T	50 4T	50 4T	50 4T	50 4T
3113905 €204,00 Ø 49	3113243 €214,14 Ø 52	3113243 €214,14 Ø 52	3113243 €214,14 Ø 52	-	3113243 €214,14 Ø 52	3113243 €214,14 Ø 52	3113243 €214,14 Ø 52
-	-	-	-	-	-	-	-
63	*61*	*61*	*61*	-	*61*	*61*	*61*
-	-	-	-	-	-	-	-
-	-	-	-	-	-	-	-
5111597 €61,80	5113790 €58,71	5113790 €58,71	5113790 €58,71	-	5113790 €58,71	5113790 €58,71	5113790 €58,71
61 9831 €19,49	-	-	-	-	-	-	-
6113191 €25,34	6113501 €20,40	6113501 €20,40	-	6113503 €22,00	-	6113501 €20,40	-
66 9420.G0 €10,00 gr.06,1	66 9823.L0 €9,50 gr.06	66 9823.L0 €9,50 gr.06	66 9823.L0 €9,50 gr.06	-	66 9823.L0 €9,50 gr.06	66 9823.L0 €9,50 gr.06	66 9823.L0 €9,50 gr.06
66 9420.I0 €10,00 gr.06,5	66 9823.L0 €9,50 gr.06	66 9823.L0 €9,50 gr.06	66 9823.L0 €9,50 gr.06	-	66 9823.L0 €9,50 gr.06	-	66 9823.L0 €9,50 gr.06
PG.438	-	-	-	-	-	-	-
-	-	-	-	-	-	-	-
-	61 8317 €95,61	61 8317 €95,61	61 8317 €95,61	-	61 8317 €95,61	61 8317 €95,61	61 8317 €95,61
-	52 8797 €47,30	52 8797 €47,30	52 8797 €47,30	-	52 8797 €47,30	52 8797 €47,30	52 8797 €47,30
-	52 7880 €77,89	52 7880 €77,89	52 7880 €77,89	-	52 7880 €77,89	52 7880 €77,89	52 7880 €77,89
-	5214111 €63,00 Ø 107	5214111 €63,00 Ø 107	5214111 €63,00 Ø 107	-	5214111 €63,00 Ø 107	5214111 €63,00 Ø 107	5214111 €63,00 Ø 107
-	5214110 €93,84 Ø 107	5214110 €93,84 Ø 107	5214110 €93,84 Ø 107	-	5214110 €93,84 Ø 107	5214110 €93,84 Ø 107	5214110 €93,84 Ø 107
-	5214738 €156,00 Ø 107	5214738 €156,00 Ø 107	5214738 €156,00 Ø 107	-	5214738 €156,00 Ø 107	5214738 €156,00 Ø 107	5214738 €156,00 Ø 107
-	7711115 €22,60 Ø 107	7711115 €22,60 Ø 107	7711115 €22,60 Ø 107	-	7711115 €22,60 Ø 107	7711115 €22,60 Ø 107	7711115 €22,60 Ø 107
-	7711207 €33,45 Ø 107	7711207 €33,45 Ø 107	7711207 €33,45 Ø 107	-	7711207 €33,45 Ø 107	7711207 €33,45 Ø 107	7711207 €33,45 Ø 107
-	7714147 €90,00 Ø 107	7714147 €90,00 Ø 107	7714147 €90,00 Ø 107	-	7714147 €90,00 Ø 107	7714147 €90,00 Ø 107	7714147 €90,00 Ø 107





MALOSSI

Scooter Sport

50 → 124 4T

with ENGINE 

HONDA			HUPPER
VISION ie	VISION ie	ZOOMER	MONTECARLO 30
(AF72E)	(JF31E)		(139QMB)
50 4T 	110 4T 	50 4T LC	50 4T 

	SPORT SPRINGS FOR FLY / DELTA CLUTCH	-	-	-	29 8746 € 14,50
	MHR SPRINGS FOR FLY / DELTA CLUTCH	-	-	-	29 8747 € 19,40
	SPRINGS FOR ORIGINAL CLUTCH	29 9605 € 16,20	2912536 € 15,56	-	29 9605 € 16,20
	RED SPONGE FOR ORIGINAL AIR BOX	-	-	-	-
	DOUBLE RED SPONGE FOR ORIGINAL AIR BOX	-	-	-	-
	GEARS HTQ PRIMARY	-	-	-	-
	GEARS HTQ SECONDARY (COUPLING Ø)	-	-	-	-
	PINWHEEL SHAFT	-	-	-	-
	ROLLER CRANKCASE	-	-	-	-
	ROLLER CRANKCASE TEAM		-	-	-
	SPORT SCREEN SCREEN	-	-	-	-
	BRAKE PADS FRONT ORGANIC BRAKE PADS	-	-	-	-
	BRAKE PADS MHR FRONT ORGANIC BRAKE PADS	-	-	-	-
	BRAKE PADS MHR SYNT FRONT SINTERED BRAKE PADS	-	-	-	-
	BRAKE POWER REAR BRAKE SHOES	-	-	-	-
	DISC FRONT BRAKE DISCS	-	-	-	-
	WHOOOP DISC FRONT BRAKE DISCS	-	-	-	-
	RS3 REAR SHOCK ABSORBER	-	-	-	46 7906 € 140,92
	RS1 REAR SHOCK ABSORBER	-	-	-	-
	RS24 REAR SHOCK ABSORBER	-	-	-	46 7589 € 221,96
	RS24 FRONT SHOCK ABSORBER	-	-	-	-

ITALJET		KYMCO					
TORPEDO	AGILITY R10/12 - RS euro 2	AGILITY R16 - RS euro 2	DINK euro 2	FILLY	LIKE euro 2	PEOPLE euro 2	PEOPLE S euro 2
	(KL10B)	(KL10B)			(KG10A)		(BB10)
50 4T	50 4T	50 4T	50 4T	50 4T	50 4T	50 4T	50 4T
-	-	-	-	-	-	-	-
-	-	-	-	-	-	-	-
-	29 9605 € 16,20	29 9605 € 16,20	29 9605 € 16,20	-	29 9605 € 16,20	29 9605 € 16,20	29 9605 € 16,20
-	-	-	-	-	-	-	-
-	-	-	-	-	-	-	-
-	-	6714189 € 77,01 z 16/57	-	-	-	6714189 € 77,01 z 16/57	-
-	-	-	-	-	-	-	-
-	-	-	-	-	-	-	-
-	-	-	-	-	-	-	-
-	-	-	-	-	-	-	-
-	-	6215858 € 8,84 2008->	-	-	-	6215858 € 8,84 2003->	6215858 € 8,84 2006->08
-	-	-	-	-	-	-	-
-	-	-	-	-	-	-	-
-	-	-	-	-	-	-	-
-	-	-	-	-	-	-	-
-	-	-	-	-	-	-	-
-	-	-	-	-	-	-	-
-	-	-	-	-	-	-	-
-	-	-	-	-	-	-	-
-	-	-	-	-	-	-	-
-	-	-	-	-	-	-	-
-	-	-	-	-	-	-	-
-	-	-	-	-	-	-	-
-	-	-	-	-	-	-	-
-	-	-	-	-	-	-	-
-	-	-	-	-	-	-	-
-	-	-	-	-	-	-	-





MALOSSI

Scooter Sport

50 → 124 4T

with ENGINE **KYMCO****MALAGUTI**SENTO
euro 2SUPER 8
euro 2VITALITY
euro 2CENTRO
euro 2

(KL10)

(SG10)

(C432M)

50 4T



50 4T



50 4T



50 4T



	CYLINDER 4 STROKE ALUMINIUM	3113243 €214,14 Ø 52	3113243 €214,14 Ø 52	3113243 €214,14 Ø 52	3113905 €204,00 Ø 49
	CYLINDER I-TECH ALUMINIUM EQUIPPED WITH CDI	-	-	-	-
	POWER CAM CAMSHAFT	*61*	*61*	*61*	*61*
	DIGITRONIC COIL VARIABLE ADVANCE	-	-	-	-
	TC UNIT O2 controller LAMBDA EMULATOR	-	-	-	-
	MULTIVAR VARIATOR	5113790 €58,71	5113790 €58,71	5113790 €58,71	5111597 €61,80
	X SPECIAL BELT BELT	-	-	-	61 9831 €19,49
	X K BELT BELT	-	6113501 €20,40	6113501 €20,40	6113191 €25,34
	HTRoll ROLLERS FOR MULTIVAR 2000	66 9823.LO €9,50 gr.06	66 9823.LO €9,50 gr.06	66 9823.LO €9,50 gr.06	66 9420.G0 €10,00 gr.06,1
	HTRoll ROLLERS FOR ORIGINAL VARIATOR	66 9823.LO €9,50 gr.06	66 9823.LO €9,50 gr.06	-	66 9420.I0 €10,00 gr.06,5
	VARIABLE-SPEED DRIVE ADJUSTER SPRING FOR ORIGINAL VARIATOR	-	-	-	PG.438 PG.438
	TORSION CONTROLLER ANTIFRICTION	-	-	-	-
	TORQUE DRIVER MOBILE DRIVEN SPLIT PULLEY	61 8317 €95,61	61 8317 €95,61	61 8317 €95,61	61 9100 €85,57
	FLY CLUTCH / MAXI FLY CLUTCH NOT ADJUSTABLE CLUTCH	52 8797 €47,30	52 8797 €47,30	52 8797 €47,30	52 8797 €47,30
	DELTA CLUTCH / MAXI DELTA CLUTCH ADJUSTABLE CLUTCH	52 7880 €77,89	52 7880 €77,89	52 7880 €77,89	52 7880 €77,89
	FLY SYSTEM CLUTCH BELL + NOT ADJUSTABLE CLUTCH	5214111 €63,00 Ø 107	5214111 €63,00 Ø 107	5214111 €63,00 Ø 107	5214111 €63,00 Ø 107
	DELTA SYSTEM / MAXI DELTA SYSTEM CLUTCH BELL + ADJUSTABLE CLUTCH	5214110 €93,84 Ø 107	5214110 €93,84 Ø 107	5214110 €93,84 Ø 107	5214110 €93,84 Ø 107
	DELTA SYSTEM MHR CLUTCH BELL + ADJUSTABLE CLUTCH	5214738 €156,00 Ø 107	5214738 €156,00 Ø 107	5214738 €156,00 Ø 107	5214738 €156,00 Ø 107
	CLUTCH BELL CLUTCH BELL (SMOOTH RING)	7711115 €22,60 Ø 107	7711115 €22,60 Ø 107	7711115 €22,60 Ø 107	7711115 €22,60 Ø 107
	WING CLUTCH BELL / MAXI WING CLUTCH BELL (FINNED RING)	7711207 €33,45 Ø 107	7711207 €33,45 Ø 107	7711207 €33,45 Ø 107	7711207 €33,45 Ø 107
	WING CLUTCH BELL MHR CLUTCH BELL (FINNED RING)	7714147 €90,00 Ø 107	7714147 €90,00 Ø 107	7714147 €90,00 Ø 107	7714147 €90,00 Ø 107

02 - Crankcase MODIFICATIONS : BORING AND CHAMFERING

61 - TO COUPLE ONLY with MALOSSI CYLINDERS : 5914143 € 178,00

63 - TO COUPLE ONLY with MALOSSI CYLINDERS : 5911988 € 110,73

MALAGUTI		MBK		OVER		PEUGEOT			PIAGGIO						
CIAK MASTER euro 2		DVD		BOOSTER X ie euro 2		B3		SPEEDFIGHT 3		TWEET euro 2		V-CLIC		FLY	
		(139 QMB)				(LJ1P38MB)		(XS1P37QMA-2)							
50 4T		50 4T		50 4T	LC	50 4T	LC	50 4T		50 4T		50 4T		50 4T	
3113905		3113243		-		3113579		-		-		3113243 *02*		3113905	
€ 204,00	Ø 49	€ 214,14	Ø 52			€ 298,70	Ø 44					€ 214,14	Ø 52	€ 204,00	Ø 49
-		-		-		-		-		-		-		-	
63		*61*		-		-		-		-		*61*		*61*	
-		-		-		-		-		-		-		-	
-		-		-		-		-		-		-		-	
5111597		5113139		5113603		-		5114206		5114206		5113139		5111597	
€ 61,80		€ 58,71		€ 58,71				€ 59,34		€ 59,34		€ 58,71		€ 61,80	
61 9831		-		6112741		61 9832		6112735		6112735		-		6111246	
€ 19,49				€ 15,25		€ 17,04		€ 15,46		€ 15,46				€ 18,50	
6113191		6113397		6112742		61 7587		6112736		6112736		6113397		-	
€ 25,34		€ 22,44		€ 26,33		€ 28,25		€ 27,23		€ 27,23		€ 22,44			
66 9420.G0		66 9823.M0		66 9823.L0		-		66 9823.L0		66 9823.L0		66 9823.M0		66 9420.G0	
€ 10,00 gr.06,1		€ 9,50 gr.07		€ 9,50 gr.06				€ 9,50 gr.06		€ 9,50 gr.06		€ 9,50 gr.07		€ 10,00 gr.06,1	
66 9420.I0		66 9417.E0		-		66 9417.E0		66 9823.L0		66 9823.L0		66 9823.L0		66 9420.I0	
€ 10,00 gr.06,5		€ 7,24 gr.04,8				€ 7,24 gr.04,8		€ 9,50 gr.06		€ 9,50 gr.06		€ 9,50 gr.06		€ 10,00 gr.06,5	
PG.438		PG.438		-		PG.438		PG.438		PG.438		PG.438		PG.438	
-		-		-		-		-		-		-		-	
61 9100		61 8317		61 9223		61 8317		-		-		61 8317		61 9100	
€ 85,57		€ 95,61		€ 85,57		€ 95,61						€ 95,61		€ 85,57	
52 8797		52 8797		52 9450		52 8797		5215166		-		52 8797		52 8797	
€ 47,30		€ 47,30		€ 47,30		€ 47,30		€ 47,30				€ 47,30		€ 47,30	
52 7880		52 7880		52 9451		52 7880		-		-		52 7880		52 7880	
€ 77,89		€ 77,89		€ 77,89		€ 77,89						€ 77,89		€ 77,89	
5214111		5214111		5214112		5214111		-		-		5214111		5214111	
€ 63,00 Ø 107		€ 63,00 Ø 107		€ 63,00 Ø 107		€ 63,00 Ø 107						€ 63,00 Ø 107		€ 63,00 Ø 107	
5214110		5214110		5214113		5214110		-		-		5214110		5214110	
€ 93,84 Ø 107		€ 93,84 Ø 107		€ 93,84 Ø 107		€ 93,84 Ø 107						€ 93,84 Ø 107		€ 93,84 Ø 107	
5214738		5214738		5214739		5214738		-		-		5214738		5214738	
€ 156,00 Ø 107		€ 156,00 Ø 107		€ 156,00 Ø 107		€ 156,00 Ø 107						€ 156,00 Ø 107		€ 156,00 Ø 107	
7711115		7711115		7711124		7711115		-		-		7711115		7711115	
€ 22,60 Ø 107		€ 22,60 Ø 107		€ 22,60 Ø 107		€ 22,60 Ø 107						€ 22,60 Ø 107		€ 22,60 Ø 107	
7711207		7711207		7711166		7711207		-		-		7711207		7711207	
€ 33,45 Ø 107		€ 33,45 Ø 107		€ 33,45 Ø 107		€ 33,45 Ø 107						€ 33,45 Ø 107		€ 33,45 Ø 107	
7714147		7714147		7714313		7714147		-		-		7714147		7714147	
€ 90,00 Ø 107		€ 90,00 Ø 107		€ 90,00 Ø 107		€ 90,00 Ø 107						€ 90,00 Ø 107		€ 90,00 Ø 107	

















MALOSS

Scooter Sport

50 → 124 4T

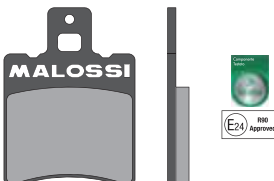
with ENGINE 







KYMCO			MALAGUTI
SENTO euro 2	SUPER 8 euro 2	VITALITY euro 2	CENTRO euro 2
	(KL10)	(SG10)	(C432M)
50 4T 	50 4T 	50 4T 	50 4T 

	SPORT SPRINGS FOR FLY / DELTA CLUTCH	-	-	-	29 8746 € 14,50
	MHR SPRINGS FOR FLY / DELTA CLUTCH	-	-	-	29 8747 € 19,40
	SPRINGS FOR ORIGINAL CLUTCH	29 9605 € 16,20	29 9605 € 16,20	29 9605 € 16,20	29 7454 € 16,20
	RED SPONGE FOR ORIGINAL AIR BOX	-	-	-	-
	DOUBLE RED SPONGE FOR ORIGINAL AIR BOX	-	-	-	-
	GEARS HTQ PRIMARY	-	-	-	-
	GEARS HTQ SECONDARY (COUPLING Ø)	-	-	-	6711135 € 58,86 z 15/55 (17)
	PINWHEEL SHAFT	-	-	-	6714530 € 66,30
	ROLLER CRANKCASE	-	-	-	2514521 *66* € 95,00
	ROLLER CRANKCASE TEAM	PG. 486	-	-	2514603 *66* € 95,00
	SPORT SCREEN SCREEN	-	-	-	-
	BRAKE PADS FRONT ORGANIC BRAKE PADS	-	-	-	6215059 € 8,84
	BRAKE PADS MHR FRONT ORGANIC BRAKE PADS	-	-	-	6212164 € 8,50
	BRAKE PADS MHR SYNT FRONT SINTERED BRAKE PADS	-	-	-	-
	BRAKE POWER REAR BRAKE SHOES	-	-	-	-
	DISC FRONT BRAKE DISCS	-	-	-	-
	WHOOB DISC FRONT BRAKE DISCS	-	-	-	-
	RS3 REAR SHOCK ABSORBER	-	-	-	-
	RS1 REAR SHOCK ABSORBER	-	-	-	-
	RS24 REAR SHOCK ABSORBER	-	-	-	-
	RS24 FRONT SHOCK ABSORBER	-	-	-	-

66 - NOT to be used on VEHICLE WITH ORIGINAL PRIMARY GEARS

84 - ALSO AVAILABLE: REAR, WHOOB disc 6212603 € 72,56 - BRAKE PADS MHR SYNT 6215019 € 16,64

PG - SPECIFICATIONS on the PAGE indicated in the TITLE of the LINE

MALAGUTI		MBK		OVER		PEUGEOT			PIAGGIO	
CIAK MASTER euro 2	DVD	BOOSTER X ie euro 2	B3	SPEEDFIGHT 3	TWEET euro 2	V-CLIC	FLY			
	(139 QMB)		(LJ1P38MB)	(XS1P37QMA-2)						
50 4T 	50 4T 	50 4T LC	50 4T LC	50 4T 	50 4T 	50 4T 	50 4T 			
29 8746 € 14,50	29 8746 € 14,50	-	29 8746 € 14,50	-	-	29 8746 € 14,50	29 8746 € 14,50			
29 8747 € 19,40	29 8747 € 19,40	-	29 8747 € 19,40	-	-	29 8747 € 19,40	29 8747 € 19,40			
-	29 9605 € 16,20	29 9605 € 16,20	29 9605 € 16,20	2914202 € 15,04	2914202 € 15,04	29 9605 € 16,20	-			
-	-	-	-	-	-	-	-			
-	-	-	-	-	-	-	-			
-	-	-	-	-	-	-	-			
6711135 € 58,86 z 15/55 (17)	-	-	-	-	-	-	-			
6714530 € 66,30	-	-	-	-	-	-	6714530 € 66,30			
2514521 *66* € 95,00	-	-	-	-	-	-	-			
2514603 *66* € 95,00	-	-	-	-	-	-	-			
-	-	-	-	-	-	-	-			
6215042 € 5,72	6215044 € 6,97	-	-	-	-	6215044 € 6,97	-			
6215080 € 6,00	62 9084 € 6,90	-	-	-	-	62 9084 € 6,90	-			
6215007 € 11,96	-	-	*84*	-	-	-	-			
-	-	-	-	-	-	-	-			
-	6214097 € 62,00	-	*84*	-	-	6214097 € 62,00	-			
-	-	-	46 7905 € 140,92	-	-	-	-			
-	-	-	-	-	-	-	-			
-	-	-	46 7588 € 255,97	-	-	-	-			
-	-	-	-	-	-	-	-			



MALOSSI

Scooter Sport

50 → 124 4T

with ENGINE 

PIAGGIO

NEW FLY 4V
euro 2

FREE

LIBERTY

LIBERTY 4V
euro 2

50 4T



100 4T



50 4T



50 4T



	CYLINDER 4 STROKE ALUMINIUM	3113905 € 204,00 Ø 49	-	3113905 € 204,00 Ø 49	3113905 € 204,00 Ø 49
	CYLINDER I-TECH ALUMINIUM EQUIPPED WITH CDI	-	-	-	-
	POWER CAM CAMSHAFT	*60*	-	*63*	*60*
	DIGITRONIC COIL VARIABLE ADVANCE	5514396 € 149,50	-	-	5514396 € 149,50
	TC UNIT 02 controller LAMBDA EMULATOR	-	-	-	-
	MULTIVAR VARIATOR	5111597 € 61,80	5112024 € 60,00	5111597 € 61,80	5111597 € 61,80
	X SPECIAL BELT BELT	-	-	61 9831 € 19,49	-
	X K BELT BELT	-	6113191 € 25,34	6113191 € 25,34	6113191 € 25,34
	HTRoll ROLLERS FOR MULTIVAR 2000	66 9420.G0 € 10,00 gr.06,1	66 9420.10 € 10,00 gr.10	66 9420.G0 € 10,00 gr.06,1	66 9420.G0 € 10,00 gr.06,1
	HTRoll ROLLERS FOR ORIGINAL VARIATOR	66 9420.C0 € 10,00 gr.05	-	66 9420.10 € 10,00 gr.06,5	66 9420.10 € 10,00 gr.06,5
	VARIABLE-SPEED DRIVE ADJUSTER SPRING FOR ORIGINAL VARIATOR	PG. 438 PG.438	-	PG.438	PG.438
	TORSION CONTROLLER ANTIFRICTION	-	-	-	-
	TORQUE DRIVER MOBILE DRIVEN SPLIT PULLEY	61 9100 € 85,57	-	61 9100 € 85,57	61 9100 € 85,57
	FLY CLUTCH / MAXI FLY CLUTCH NOT ADJUSTABLE CLUTCH	52 8797 € 47,30	-	52 8797 € 47,30	52 8797 € 47,30
	DELTA CLUTCH / MAXI DELTA CLUTCH ADJUSTABLE CLUTCH	52 7880 € 77,89	-	52 7880 € 77,89	52 7880 € 77,89
	FLY SYSTEM CLUTCH BELL + NOT ADJUSTABLE CLUTCH	5214111 € 63,00 Ø 107	-	5214111 € 63,00 Ø 107	5214111 € 63,00 Ø 107
	DELTA SYSTEM / MAXI DELTA SYSTEM CLUTCH BELL + ADJUSTABLE CLUTCH	5214110 € 93,84 Ø 107	-	5214110 € 93,84 Ø 107	5214110 € 93,84 Ø 107
	DELTA SYSTEM MHR CLUTCH BELL + ADJUSTABLE CLUTCH	5214738 € 156,00 Ø 107	-	5214738 € 156,00 Ø 107	5214738 € 156,00 Ø 107
	CLUTCH BELL CLUTCH BELL (SMOOTH RING)	7711115 € 22,60 Ø 107	-	7711115 € 22,60 Ø 107	7711115 € 22,60 Ø 107
	WING CLUTCH BELL / MAXI WING CLUTCH BELL (FINNED RING)	7711207 € 33,45 Ø 107	-	7711207 € 33,45 Ø 107	7711207 € 33,45 Ø 107
	WING CLUTCH BELL MHR CLUTCH BELL (FINNED RING)	7714147 € 90,00 Ø 107	-	7714147 € 90,00 Ø 107	7714147 € 90,00 Ø 107

02 - Crankcase MODIFICATIONS : BORING AND CHAMFERING***60*** - TO COUPLE ONLY with MALOSSİ CYLINDERS : 5914211 € 116,39***61*** - TO COUPLE ONLY with MALOSSİ CYLINDERS : 5914143 € 178,00***63*** - TO COUPLE ONLY with MALOSSİ CYLINDERS : 5911988 € 110,73

PIAGGIO			SYM			VESPA	
LIBERTY	ZIP	ZIP	MIO euro 3	SYMPHONY euro 2	SYMPLY euro 2	ET4	LX
			(A5A-1)	(XS1P37QMA-2)	(XS1P39QMB)		
100 4T	50 4T	100 4T	100 4T	50 4T	50 4T	50 4T	50 4T
-	3113905 € 204,00 Ø 49	-	-	-	3113243 *02* € 214,14 Ø 52	3113905 € 204,00 Ø 49	3113905 € 204,00 Ø 49
-	-	-	-	-	-	-	-
-	*63*	-	-	-	*61*	*63*	*63*
-	-	-	-	-	-	-	-
-	-	-	-	-	-	-	-
5112024 € 60,00	5111597 € 61,80	5112024 € 60,00	-	5114206 € 59,34	5113790 € 58,71	5111597 € 61,80	5111597 € 61,80
-	6111246 € 18,50	-	-	6111295 € 17,71	-	6111246 € 18,50	6111246 € 18,50
6113191 € 25,34	-	-	-	6111294 € 28,38	-	-	-
66 9420.10 € 10,00 gr.10	66 9420.G0 € 10,00 gr.06,1	66 9420.10 € 10,00 gr.10	-	66 9823.L0 € 9,50 gr.06	66 9823.L0 € 9,50 gr.06	66 9420.G0 € 10,00 gr.06,1	66 9420.G0 € 10,00 gr.06,1
-	66 9420.I0 € 10,00 gr.06,5	-	-	66 9823.L0 € 9,50 gr.06	66 9823.L0 € 9,50 gr.06	66 9420.I0 € 10,00 gr.06,5	66 9420.I0 € 10,00 gr.06,5
-	PG.438	-	-	PG.438	-	PG.438	PG.438
-	-	-	-	-	-	-	-
-	61 9100 € 85,57	-	-	-	61 8317 € 95,61	61 9100 € 85,57	61 9100 € 85,57
-	52 8797 € 47,30	-	-	-	52 8797 € 47,30	52 8797 € 47,30	52 8797 € 47,30
-	52 7880 € 77,89	-	-	-	52 7880 € 77,89	52 7880 € 77,89	52 7880 € 77,89
-	5214111 € 63,00 Ø 107	-	-	-	5214111 € 63,00 Ø 107	5214111 € 63,00 Ø 107	5214111 € 63,00 Ø 107
-	5214110 € 93,84 Ø 107	-	-	-	5214110 € 93,84 Ø 107	5214110 € 93,84 Ø 107	5214110 € 93,84 Ø 107
-	5214738 € 156,00 Ø 107	-	-	-	5214738 € 156,00 Ø 107	5214738 € 156,00 Ø 107	5214738 € 156,00 Ø 107
-	7711115 € 22,60 Ø 107	-	-	-	7711115 € 22,60 Ø 107	7711115 € 22,60 Ø 107	7711115 € 22,60 Ø 107
-	7711207 € 33,45 Ø 107	-	-	-	7711207 € 33,45 Ø 107	7711207 € 33,45 Ø 107	7711207 € 33,45 Ø 107
-	7714147 € 90,00 Ø 107	-	-	-	7714147 € 90,00 Ø 107	7714147 € 90,00 Ø 107	7714147 € 90,00 Ø 107



MALOSSI

Scooter Sport

50 → 124 4T

with ENGINE 

PIAGGIO

NEW FLY 4V
euro 2

FREE

LIBERTY

LIBERTY 4V
euro 2

50 4T



100 4T



50 4T



50 4T



	SPORT SPRINGS FOR FLY / DELTA CLUTCH	29 8746 € 14,50	-	29 8746 € 14,50	29 8746 € 14,50
	MHR SPRINGS FOR FLY / DELTA CLUTCH	29 8747 € 19,40	-	29 8747 € 19,40	29 8747 € 19,40
	SPRINGS FOR ORIGINAL CLUTCH	29 7454 € 16,20	-	-	-
	RED SPONGE FOR ORIGINAL AIR BOX	-	-	1412117 € 4,71	1412117 € 4,71
	DOUBLE RED SPONGE FOR ORIGINAL AIR BOX	1414532 € 6,70	-	1414511 € 7,26	1414511 € 7,26
	GEARS HTQ PRIMARY	-	-	-	-
	GEARS HTQ SECONDARY (COUPLING Ø)	6711135 € 58,86 z 15/55 (17)	-	6711135 € 58,86 z 15/55 (17)	6711135 € 58,86 z 15/55 (17)
	PINWHEEL SHAFT	6714530 € 66,30	-	6714530 € 66,30	6714530 € 66,30
	ROLLER CRANKCASE	-	-	2514521 *66* € 95,00	2514521 *66* € 95,00
	ROLLER CRANKCASE TEAM	PG. 486	-	2514603 *66* € 95,00	2514603 *66* € 95,00
	SPORT SCREEN SCREEN	-	-	-	-
	BRAKE PADS FRONT ORGANIC BRAKE PADS	-	-	6215049 € 6,24 2000->	6215049 € 6,24 2000->
	BRAKE PADS MHR FRONT ORGANIC BRAKE PADS	-	-	6215074 € 6,30 2000->	6215074 € 6,30 2000->
	BRAKE PADS MHR SYNT FRONT SINTERED BRAKE PADS	-	-	6215006 € 11,96 2000->	6215006 € 11,96 2000->
	BRAKE POWER REAR BRAKE SHOES	-	-	-	-
	DISC FRONT BRAKE DISCS	-	-	-	-
	WHOOOP DISC FRONT BRAKE DISCS	-	-	-	-
	RS3 REAR SHOCK ABSORBER	-	-	-	-
	RS1 REAR SHOCK ABSORBER	-	-	-	-
	RS24 REAR SHOCK ABSORBER	-	-	-	-
	RS24 FRONT SHOCK ABSORBER	-	-	-	-

66 - NOT to be used on VEHICLE WITH ORIGINAL PRIMARY GEARS

PG - SPECIFICATIONS on the PAGE indicated in the TITLE of the LINE

PIAGGIO			SYM			VESPA	
LIBERTY	ZIP	ZIP	MIO euro 3	SYMPHONY euro 2	SYMPLY euro 2	ET4	LX
			(A5A-1)	(XS1P37QMA-2)	(XS1P39QMB)		
100 4T	50 4T	100 4T	100 4T	50 4T	50 4T	50 4T	50 4T
-	29 8746 € 14,50	-	-	-	-	29 8746 € 14,50	29 8746 € 14,50
-	29 8747 € 19,40	-	-	-	-	29 8747 € 19,40	29 8747 € 19,40
-	-	-	29 9605 € 16,20	2914202 € 15,04	29 9605 € 16,20	-	-
-	1411420 € 3,56	-	-	-	-	-	-
-	1414500 € 5,40	-	-	-	-	-	-
-	-	-	-	-	-	-	-
-	6712144 € 61,83 z 15/47 (17)	-	-	-	-	6712144 € 61,83 z 15/47 (17)	-
-	6714530 € 66,30	-	-	-	-	6714530 € 66,30	6714530 € 66,30
-	2514521 *66* € 95,00	-	-	-	-	2514521 *66* € 95,00	2514521 *66* € 95,00
-	2514603 *66* € 95,00	-	-	-	-	2514603 *66* € 95,00	2514603 *66* € 95,00
-	-	-	-	-	-	-	4516054 € 73,80
-	6215049 € 6,24 2000->	-	-	6215856 € 7,80 2009->	6215856 € 7,80 2007->09	6215049 € 6,24 1999->	-
-	6215074 € 6,30 2000->	-	-	-	-	6215074 € 6,30 1999->	-
-	6215006 € 11,96 2000->	-	-	-	-	6215006 € 11,96 1999->	-
-	6215328 € 18,39 2000->	-	-	-	-	6215328 € 18,39 1999->	6215328 € 18,39
-	-	-	-	-	-	-	-
-	-	-	-	-	6212603 € 72,56	-	-
-	46 7908 € 140,92	-	-	-	-	46 7908 € 140,92	-
-	4615432 € 94,86	-	-	-	-	4615432 € 94,86	-
-	46 8308 € 248,50	-	-	-	-	46 8308 € 248,50	-
-	-	-	-	-	-	-	-



MALOSSI

Scooter Sport

50 → 124 4T

with ENGINE 

VESPA

LX 4V
euro 2Primavera 4V
euro 2S 4V
euro 2Sprint 4V
euro 2

(C532M)

(C386M)

50 4T

50 4T



50 4T



50 4T



	CYLINDER 4 STROKE ALUMINIUM	3113905 € 204,00 Ø 49	3113905 € 204,00 Ø 49	3113905 € 204,00 Ø 49	3113905 € 204,00 Ø 49
	CYLINDER I-TECH ALUMINIUM EQUIPPED WITH CDI	-	-	-	-
	POWER CAM CAMSHAFT	*60*	*60*	*60*	*60*
	DIGITRONIC COIL VARIABLE ADVANCE	5514396 € 149,50	5514396 € 149,50	5514396 € 149,50	5514396 € 149,50
	TC UNIT 02 controller LAMBDA EMULATOR	-	-	-	-
	MULTIVAR VARIATOR	5111597 € 61,80	5111597 € 61,80	5111597 € 61,80	5111597 € 61,80
	X SPECIAL BELT BELT	6111246 € 18,50	-	6111246 € 18,50	-
	X K BELT BELT	-	6116424 € 21,00	-	-
	HTRoll ROLLERS FOR MULTIVAR 2000	66 9420.G0 € 10,00 gr.06,1	66 9420.G0 € 10,00 gr.06,1	66 9420.G0 € 10,00 gr.06,1	66 9420.G0 € 10,00 gr.06,1
	HTRoll ROLLERS FOR ORIGINAL VARIATOR	66 9420.C0 € 10,00 gr.05	66 9420.C0 € 10,00 gr.05	66 9420.C0 € 10,00 gr.05	66 9420.I0 € 10,00 gr.06,5
	VARIABLE-SPEED DRIVE ADJUSTER SPRING FOR ORIGINAL VARIATOR	PG. 438 PG.438	PG.438	PG.438	PG.438
	TORSION CONTROLLER ANTIFRICTION	-	-	-	-
	TORQUE DRIVER MOBILE DRIVEN SPLIT PULLEY	61 9100 € 85,57	61 9100 € 85,57	61 9100 € 85,57	61 9100 € 85,57
	FLY CLUTCH / MAXI FLY CLUTCH NOT ADJUSTABLE CLUTCH	52 8797 € 47,30	52 8797 € 47,30	52 8797 € 47,30	52 8797 € 47,30
	DELTA CLUTCH / MAXI DELTA CLUTCH ADJUSTABLE CLUTCH	52 7880 € 77,89	52 7880 € 77,89	52 7880 € 77,89	52 7880 € 77,89
	FLY SYSTEM CLUTCH BELL + NOT ADJUSTABLE CLUTCH	5214111 € 63,00 Ø 107	5214111 € 63,00 Ø 107	5214111 € 63,00 Ø 107	5214111 € 63,00 Ø 107
	DELTA SYSTEM / MAXI DELTA SYSTEM CLUTCH BELL + ADJUSTABLE CLUTCH	5214110 € 93,84 Ø 107	5214110 € 93,84 Ø 107	5214110 € 93,84 Ø 107	5214110 € 93,84 Ø 107
	DELTA SYSTEM MHR CLUTCH BELL + ADJUSTABLE CLUTCH	5214738 € 156,00 Ø 107	5214738 € 156,00 Ø 107	5214738 € 156,00 Ø 107	5214738 € 156,00 Ø 107
	CLUTCH BELL CLUTCH BELL (SMOOTH RING)	7711115 € 22,60 Ø 107	7711115 € 22,60 Ø 107	7711115 € 22,60 Ø 107	7711115 € 22,60 Ø 107
	WING CLUTCH BELL / MAXI WING CLUTCH BELL (FINNED RING)	7711207 € 33,45 Ø 107	7711207 € 33,45 Ø 107	7711207 € 33,45 Ø 107	7711207 € 33,45 Ø 107
	WING CLUTCH BELL MHR CLUTCH BELL (FINNED RING)	7714147 € 90,00 Ø 107	7714147 € 90,00 Ø 107	7714147 € 90,00 Ø 107	7714147 € 90,00 Ø 107

60 - TO COUPLE ONLY with MALOSSİ CYLINDERS : 5914211 € 116,39

61 - TO COUPLE ONLY with MALOSSİ CYLINDERS : 5914143 € 178,00

WT MOTORS		YAMAHA						
BILBAO	AEROX 4 ie euro 2	C3 [XF] ie euro 2	GIGGLE [XF] ie euro 2	NEO'S 4 ie euro 2	VOX [XF] ie euro 2	ZUMA FX ie		
(PEDA 139QMB)		(A311E)	(A311E)	(A316E)	(A311E)			
50 4T	50 4T LC	50 4T LC	50 4T LC	50 4T LC	50 4T LC	50 4T LC	50 4T LC	
3113243 €214,14 Ø 52	-	-	-	-	-	-	-	
-	3113864 €470,00 Ø 44	3113864 €470,00 Ø 44	3113864 €470,00 Ø 44	3113864 €470,00 Ø 44	3113864 €470,00 Ø 44	3113864 €470,00 Ø 44	-	
61	-	-	-	-	-	-	-	
-	-	-	-	-	-	-	-	
-	-	-	-	-	-	-	-	
5113139 €58,71	5113603 €58,71	5113603 €58,71	5113603 €58,71	5113603 €58,71	5113603 €58,71	5113603 €58,71	-	
-	6112741 €15,25	6112741 €15,25	6112741 €15,25	6112741 €15,25	6112741 €15,25	6112741 €15,25	-	
6113501 €20,40	6112742 €26,33	6112742 €26,33	6112742 €26,33	6112742 €26,33	6112742 €26,33	6112742 €26,33	-	
66 9823.M0 €9,50 gr.07	66 9823.L0 €9,50 gr.06	66 9823.L0 €9,50 gr.06	66 9823.L0 €9,50 gr.06	66 9823.L0 €9,50 gr.06	66 9823.L0 €9,50 gr.06	66 9823.L0 €9,50 gr.06	-	
66 9823.L0 €9,50 gr.06	66 9417.E0 €7,24 gr.04,8	66 9417.G0 €7,24 gr.06	66 9417.G0 €7,24 gr.06	66 9417.E0 €7,24 gr.04,8	66 9417.G0 €7,24 gr.06	66 9417.G0 €7,24 gr.06	-	
PG.438	-	-	-	-	-	-	-	
-	-	-	-	-	-	-	-	
61 8317 €95,61	61 9223 €85,57	61 9223 €85,57	61 9223 €85,57	61 9223 €85,57	61 9223 €85,57	61 9223 €85,57	-	
52 8797 €47,30	52 9450 €47,30	52 9450 €47,30	52 9450 €47,30	52 9450 €47,30	52 9450 €47,30	52 9450 €47,30	-	
52 7880 €77,89	52 9451 €77,89	52 9451 €77,89	52 9451 €77,89	52 9451 €77,89	52 9451 €77,89	52 9451 €77,89	-	
5214111 €63,00 Ø 107	5214112 €63,00 Ø 107	5214112 €63,00 Ø 107	5214112 €63,00 Ø 107	5214112 €63,00 Ø 107	5214112 €63,00 Ø 107	5214112 €63,00 Ø 107	-	
5214110 €93,84 Ø 107	5214113 €93,84 Ø 107	5214113 €93,84 Ø 107	5214113 €93,84 Ø 107	5214113 €93,84 Ø 107	5214113 €93,84 Ø 107	5214113 €93,84 Ø 107	-	
5214738 €156,00 Ø 107	5214739 €156,00 Ø 107	5214739 €156,00 Ø 107	5214739 €156,00 Ø 107	5214739 €156,00 Ø 107	5214739 €156,00 Ø 107	5214739 €156,00 Ø 107	-	
7711115 €22,60 Ø 107	7711124 €22,60 Ø 107	7711124 €22,60 Ø 107	7711124 €22,60 Ø 107	7711124 €22,60 Ø 107	7711124 €22,60 Ø 107	7711124 €22,60 Ø 107	-	
7711207 €33,45 Ø 107	7711166 €33,45 Ø 107	7711166 €33,45 Ø 107	7711166 €33,45 Ø 107	7711166 €33,45 Ø 107	7711166 €33,45 Ø 107	7711166 €33,45 Ø 107	-	
7714147 €90,00 Ø 107	7714313 €90,00 Ø 107	7714313 €90,00 Ø 107	7714313 €90,00 Ø 107	7714313 €90,00 Ø 107	7714313 €90,00 Ø 107	7714313 €90,00 Ø 107	-	



MALOSS

Scooter Sport

50 → 124 4T

with ENGINE 

VESPA

LX 4V
euro 2Primavera 4V
euro 2S 4V
euro 2Sprint 4V
euro 2

(C532M)

(C386M)

50 4T

50 4T



50 4T



50 4T



	SPORT SPRINGS		29 8746	29 8746	29 8746	29 8746
	FOR FLY / DELTA CLUTCH		€ 14,50	€ 14,50	€ 14,50	€ 14,50
	MHR SPRINGS		29 8747	29 8747	29 8747	29 8747
	FOR FLY / DELTA CLUTCH		€ 19,40	€ 19,40	€ 19,40	€ 19,40
	SPRINGS		29 7454	29 7454	29 7454	-
	FOR ORIGINAL CLUTCH		€ 16,20	€ 16,20	€ 16,20	-
	RED SPONGE		-	-	-	-
	FOR ORIGINAL AIR BOX		-	-	-	-
	DOUBLE RED SPONGE		1414532	1414532	1414532	-
	FOR ORIGINAL AIR BOX		€ 6,70	€ 6,70	€ 6,70	-
	GEARS HTQ		-	-	-	-
	PRIMARY		-	-	-	-
	GEARS HTQ		6712144	6711135	6712144	6711135
	SECONDARY (COUPLING Ø)		€ 61,83 z 15/47 (17)	€ 58,86 z 15/55 (17)	€ 61,83 z 15/47 (17)	€ 58,86 z 15/55 (17)
	PINWHEEL SHAFT		6714530	6714530	6714530	6714530
			€ 66,30	€ 66,30	€ 66,30	€ 66,30
	ROLLER CRANKCASE		2514521 *66*	-	2514521 *66*	-
			€ 95,00	-	€ 95,00	-
	ROLLER CRANKCASE TEAM	PG. 486	2514603 *66*	-	2514603 *66*	-
			€ 95,00	-	€ 95,00	-
	SPORT SCREEN		-	4516332	-	4516342
	SCREEN		-	€ 75,00	-	€ 75,00
	BRAKE PADS	FRONT	6215049	6215062	6215049	-
	ORGANIC BRAKE PADS		€ 6,24	€ 8,32	€ 6,24	-
	BRAKE PADS MHR	FRONT	6215074	6215079	6215074	-
	ORGANIC BRAKE PADS		€ 6,30	€ 8,20	€ 6,30	-
	BRAKE PADS MHR SYNT	FRONT	6215006	6215013	6215006	-
	SINTERED BRAKE PADS		€ 11,96	€ 16,50	€ 11,96	-
	BRAKE POWER	REAR	-	-	-	-
	BRAKE SHOES		-	-	-	-
	DISC		62 9078	62 9078	62 9078	-
	FRONT BRAKE DISCS		€ 79,00	€ 79,00	€ 79,00	-
	WHOOB DISC		6212604	6212604	6212604	-
	FRONT BRAKE DISCS		€ 76,38	€ 76,38	€ 76,38	-
	RS3		46 7908	-	46 7908	-
	REAR SHOCK ABSORBER		€ 140,92	-	€ 140,92	-
	RS1		4615432	-	4615432	-
	REAR SHOCK ABSORBER		€ 94,86	-	€ 94,86	-
	RS24		46 8308 *03*	-	46 8308 *03*	-
	REAR SHOCK ABSORBER		€ 248,50	-	€ 248,50	-
	RS24		46 7900 *03*	-	46 7900 *03*	-
	FRONT SHOCK ABSORBER		€ 222,63	-	€ 222,63	-

03 - THE PAIR of shock-absorbers IS AVAILABLE ON SALE , TOO: 46 9031 € 456,47

66 - NOT to be used on VEHICLE WITH ORIGINAL PRIMARY GEARS

PG - SPECIFICATIONS on the PAGE indicated in the TITLE of the LINE

WT MOTORS	YAMAHA						
------------------	---------------	--	--	--	--	--	--

BILBAO	AEROX 4 ie euro 2	C3 [XF] ie euro 2	GIGGLE [XF] ie euro 2	NEO'S 4 ie euro 2	VOX [XF] ie euro 2	ZUMA FX ie	
--------	----------------------	----------------------	--------------------------	----------------------	-----------------------	---------------	--

(PEDA 139QMB)		(A311E)	(A311E)	(A316E)	(A311E)		
---------------	--	---------	---------	---------	---------	--	--

50 4T	50 4T	LC	50 4T	LC	50 4T	LC	50 4T	LC	50 4T	LC	50 4T	LC
-------	-------	----	-------	----	-------	----	-------	----	-------	----	-------	----

29 8746	-	-	-	-	-	-	-	-	-	-	-	-
€ 14,50												
29 8747	-	-	-	-	-	-	-	-	-	-	-	-
€ 19,40												
29 9605	29 9605	29 9605	29 9605	29 9605	29 9605	29 9605	29 9605	29 9605	29 9605	29 9605	-	-
€ 16,20	€ 16,20	€ 16,20	€ 16,20	€ 16,20	€ 16,20	€ 16,20	€ 16,20	€ 16,20	€ 16,20	€ 16,20		
-	-	-	-	-	-	-	-	-	-	-	-	-
-	-	-	-	-	-	-	-	-	-	-	-	-
-	6714039	6714039	6714039	6714039	6714039	6714039	6714039	6714039	6714039	6714039	-	-
	€ 57,67 z 13/44	€ 57,67 z 13/44	€ 57,67 z 13/44	€ 57,67 z 13/44	€ 57,67 z 13/44	€ 57,67 z 13/44	€ 57,67 z 13/44	€ 57,67 z 13/44	€ 57,67 z 13/44	€ 57,67 z 13/44		
-	-	-	-	-	-	-	-	-	-	-	-	-
-	-	-	-	-	-	-	-	-	-	-	-	-
-	-	-	-	-	-	-	-	-	-	-	-	-
-	-	-	-	-	-	-	-	-	-	-	-	-
-	-	-	-	-	-	-	-	-	-	-	-	-
6215055	-	-	-	-	6215042	-	-	-	-	-	-	-
€ 8,84					€ 5,72							
6215078	-	-	-	-	6215080	-	-	-	-	-	-	-
€ 8,84					€ 6,00							
-	-	-	-	-	6215007	-	-	-	-	-	-	-
					€ 11,96							
-	-	-	-	-	-	-	-	-	-	-	-	-
-	-	-	-	-	-	-	-	-	-	-	-	-
-	-	-	-	-	6212603	-	-	-	-	-	-	-
					€ 72,56							
46 7906	-	-	-	-	46 7905	-	-	-	-	-	-	-
€ 140,92					€ 140,92							
-	-	-	-	-	-	-	-	-	-	-	-	-
-	-	-	-	-	-	-	-	-	-	-	-	-
46 7589	-	-	-	-	-	-	-	-	-	-	-	-
€ 221,96												
-	-	-	-	-	-	-	-	-	-	-	-	-



New TYPHOON 125 4T LC -

Turn your AIR-COOLED engine into WATER-COOLED engine in order to partake in Superscooter 4-stroke Trophy series.

Original PIAGGIO products:

829534 Cylinder head cover
829536 Head cover gasket
872635 Screw 5 pieces
830249 Buffer 5 pieces
828421 Cover breather
487989 Gasket
877136 Self-tapping screw
4847395 Intake rocker arm
4847405 Outlet rocker arm
486343 Rocker arm shaft 2 pieces
433308 Camshaft plate
877310 Special washer
486236 Crown chain sprocket
486333 Decompression counterweight
487833 Gasket
486974 Spring
8291395 Centrifuge weight
880651 Decompression housing
82644R Cam chain

Set cylinder kit / Power Cam Ø 75,5
aluminium pin Ø 15 H₂O 4-stroke
3116208 € 895,00



Crankshaft 4-stroke
pin Ø 15
5312853 € 380,00



RADIATOR MHR

300x190mm

7115508 € 183,00



ENERGY PUMP

5616363

€ 123,00



Pinwheel shaft

6715787 € 115,00



EXHAUST SYSTEM MAXI WILD LION MHR

3216760 € 875,00

New



Primary gears
HTQ z 18/45

6711492 € 183,00

Secondary gears
HTQ z 16/42

6711860 € 60,41

RED CHILLI OIL FILTER
oil filter

0313382 € 7,00



ATTENTION: It is necessary to buy all the MALOSSI and PIAGGIO products listed above.



Tr
Sup
SCOO
4STR

TORQUE DRIVER 4 stroke
6112563 € 197,30



X K belt
6115666 € 46,92



MULTIVAR 2000
5111397 € 112,35



Original PIAGGIO product:
833669 Fixed secondary pulley

MAXI DELTA CLUTCH
adjustable automatic clutch
5211821 € 120,42



MAXI CLUTCH
BELL Ø 134
7715898B € 52,00



MAXI DELTA SYSTEM
(Clutch BELL Ø 134)
5216918 € 136,00



Original PIAGGIO product:
874415 Intake manifold

RED FILTER E16
0413435 € 33,00



New CARBURETTOR
MIKUNI TM Ø 33
AM0TM33.12B € 214,68



INNER ROTOR IGNITION
5516771 € 328,50

New



REAR SHOCK ABSORBER
RS24/10-R
4616699 € 498,00

New



FORK KIT
F37R
4616779 € 1.550,00

Use front rim
Yamaha Slider
MBK Stunt

New



New
Silentbloc
0816707B € 45,00



Trofeo Super Scooter 4 STROKE

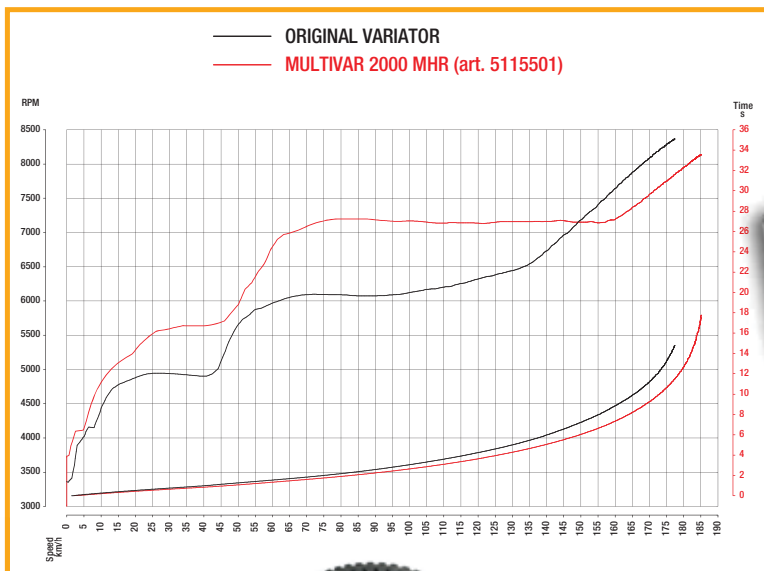

MULTIVAR 2000 MHR
5115501 € 212,00



X K BELT
6115687 € 96,90

MAXI WILD LION

homologated silencer

3215629B BMW 600 € 454,41

3215927 BMW 650 € 460,00

EXHAUST MANIFOLDS KIT

not homologated

3215630B BMW 600

€ 174,00

3215932 BMW 650

€ 174,00

BRAKE PADS MHR SYNT

Front - Rear

6215572 € 17,16

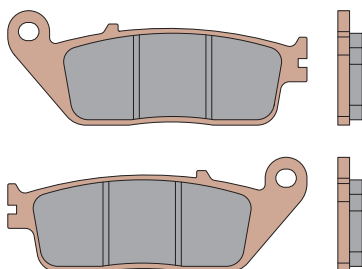

W BOX FILTER

1415541 € 39,00



**TC UNIT O2 controller -
lambda emulator**

5515721 € 88,00



Note: suggested setting example, please check in the following brand/model tables the items suitable for your vehicle.

New

8 HTRoll Ø 29,8x19,8 € 35,00
for MULTIVAR 2000 and original variator

6615657.D0 (gr.20)

6615657.F0 (gr.22)

6615657.H0 (gr.24)

6615657.L0 (gr.26)

6615657.R0 (gr.33)



**WHITE VARIATOR
ADJUSTER SPRING**

2915497.W0 € 25,75

**Exclusively for BMW C Sport 600 ie 4T LC euro 4
SPORT SCREEN - dark smoke screen**

4515571B € 65,00

SPORT SCREEN - clear screen

4515607B € 59,45

WHOOOP DISC

brake disc

Front - Rear

6215471 € 103,00

NB: the vehicle needs
2 front brake discs.



600 - 650

**FORCE MASTER 3
Electronic controller (injection)**

5515732 € 310,00



MULTIVAR 2000
5115652 € 122,57



X SPECIAL BELT
6115676 € 32,64



New

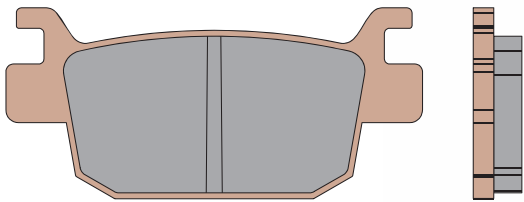

BRAKE PADS MHR SYNT
6215016 € 16,64
 (rear not homologated)

EXHAUST SYSTEM
 RX homologated
3216976 € 380,00

WHOOOP DISC
 brake disc
6212342
€ 87,50
 (rear)



HONDA
FORZA
125



MAXI CLUTCH BELL
 Ø inner 135 mm
7715916B
 € 52,00



**TC UNIT O2 controller -
 lambda emulator**
5516458
 € 89,00

SPORT SCREEN
4517067
 € ----

RACING SPRING SET
 for original clutch
2912536
 € 15,56



BRAKE PADS MHR SYNT
6215027
 € 16,64
 (front not homologated)

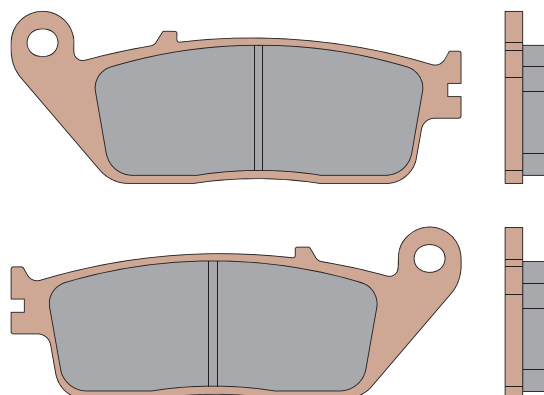

WHOOOP DISC
 brake disc
6212343
 € 99,00
 (front)



HONDA
FORZA ABS
125 ie



MAXI DELTA CLUTCH
adjustable
automatic clutch
5212487 € 112,59



MAXI WING CLUTCH BELL
Ø 125
7713376 € 38,00

MULTIVAR 2000
5115652 € 122,57

MAXI DELTA SYSTEM
(Clutch BELL Ø 125)
5216070
€ 125,46

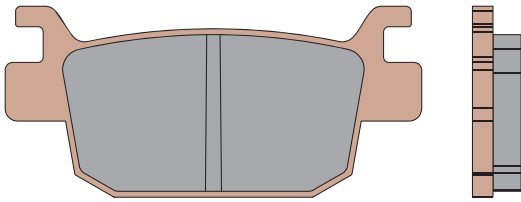

BRAKE PADS MHR SYNT
6215016 € 16,64
(rear not homologated)

EXHAUST SYSTEM RX homologated
3215557 € 380,00



X SPECIAL BELT
6115676 € 32,64



HONDA S
125 - 15



MAXI FLY CLUTCH
NOT adjustable
automatic clutch
5212522 € 70,37



MAXI CLUTCH BELL
Ø 125
7714325 € 33,00

New

MAXI FLY SYSTEM
(Clutch BELL Ø 125)

5214724
€ 100,47

SPORT SCREEN -
dark smoke screen
4516053 € 72,00



TC UNIT O2 controller -
lambda emulator
5516458
€ 89,00

BRAKE PADS MHR SYNT
6215027 € 16,64
(front not homologated)

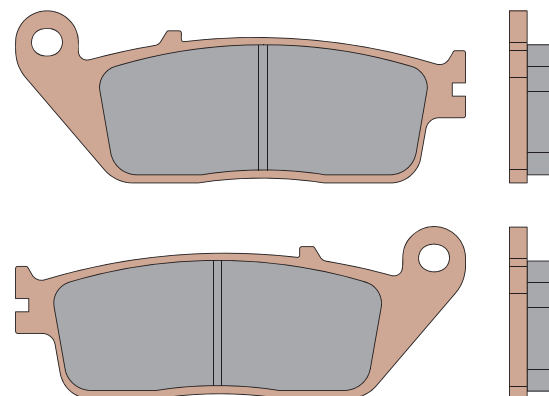

for ORIGINAL CLUTCH
2912536 € 15,56



RACING SPRINGS SET

for MAXI DELTA / FLY CLUTCH
29 9605 € 16,20

SH I ABS

50 2013->





Aluminium CYLINDER
pin Ø 14 H₂O 4-stroke

3111627 (Ø 58) - (125 cc) € 328,92
3111588 (Ø 61) - (150 cc) € 328,92



MAXI DELTA CLUTCH
adjustable
automatic clutch
5212487 € 112,59



MAXI FLY CLUTCH
NOT adjustable
automatic clutch
5212522 € 70,37



MAXI WING CLUTCH BELL
Ø 125
7713376 € 38,00



MAXI CLUTCH BELL
Ø 125
7714325 € 33,00

MAXI DELTA SYSTEM
(Clutch BELL Ø 125)
5216070 € 125,46

MAXI FLY SYSTEM
(Clutch BELL Ø 125)
5214724 € 100,47

TWINS
REAR pair shock absorber
4613162 € 246,00

EXHAUST SYSTEM RX homologated
3214796 € 380,00

WHOOOP DISC brake disc
6212342 € 87,50
(125-150 cc euro 3 2009->)
Front - Rear

FORCE MASTER 2 - Electronic controller (injection)

5514778 (125 cc) € 240,14
5515226 (150 cc) € 240,14

Force Master 2 is the innovative CDI which allows to change the injection in order to fit perfectly the new Malossi 4-stroke cylinder kit. This CDI has been scheduled with 4 different maps so as to be coupled perfectly with your vehicle whatever its setting is!

Maps were scheduled at the static test bench, thus simulating the real load of the engine, as if it were on the road. This allowed us to get a very refined carburetion, similar to the original one.



CDI

- Carburetion adjusting
- ± 20% at min/medium/max
- RPM limiter shifted to 10.000 RPM
- 4 different maps:
 - Curve 0 : original camshaft, original exhaust system
 - Curve 1 : original camshaft, Malossi exhaust system
 - Curve 2 : Malossi camshaft, original exhaust system
 - Curve 3 : Malossi camshaft, Malossi exhaust system



HONDA
SH 125
2009->

Note: suggested setting example, please check in the following brand/model tables the items suitable for your vehicle.

VENTILVAR 2000 half-pulley
for MULTIVAR 2000 and
ORIGINAL VARIATOR
6112672 € 36,72



MULTIVAR 2000
5111572 € 112,35



SPORT SCREEN - dark smoke screen
4514611 € 56,00
(125-150 cc <-2008)
4514608 € 56,00
(125-150 cc 2009->)

MULTIVAR 2000 MHR
5114065 € 122,57



TC UNIT O2 controller
lambda emulator
5514750 € 84,00



PRIMARY GEARS z 14/45
6712497 (150 cc) € 97,48



BRAKE PADS MHR SYNT
6215018 € 15,60
(front homologated
125-150 cc <-2008)

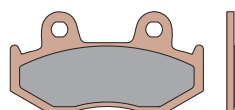

Pastillas
BRAKE PADS MHR SYNT
6215034 € 18,62
(fornt homologated
125-150 cc 2009->)

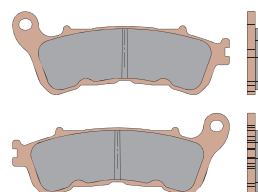

W BOX Air filter
1415333 € 45,00



for ORIGINAL CLUTCH
2912536 € 15,56



RACING SPRINGS SET

for MAXI DELTA / FLY CLUTCH
29 9605 € 16,20



X SPECIAL BELT
6114127 € 24,42



X K BELT
6116422 € 48,57



HONDA
125 - 150
->2012

MULTIVAR 2000
5113398 € 136,15



VENTILVAR 2000 half-pulley
for MULTIVAR 2000 and
ORIGINAL VARIATOR
6113523B € 44,88



X K BELT
6113590 € 97,21



MAXI DELTA CLUTCH
adjustable
automatic clutch
5211467 € 129,23



MAXI CLUTCH BELL
Ø 135
7715916B € 52,00

MAXI DELTA SYSTEM
(Clutch BELL Ø 135)
5216184 € 136,00

RED CHILLI OIL FILTER
oil filter
0313827 € 8,00



TWINS
REAR pair shock absorber
4614007 € 250,00

EXHAUST SYSTEM RX homologated
3214800 € 380,00

WHOOOP DISC brake disc
6212343 € 99,00
Front - Rear

BRAKE PADS MHR SYNT
6215016 rear homologated
€ 16,64

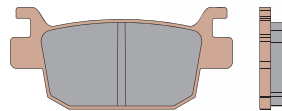

FORCE MASTER 2 - Electronic controller (injection)
5514754 € 232,96

Force Master 2 is the innovative CDI which allows to change the injection in order to fit perfectly the new Malossi 4-stroke cylinder kit. This CDI has been scheduled with 4 different maps so as to be coupled perfectly with your vehicle whatever its setting is! Maps were scheduled at the static test bench, thus simulating the real load of the engine, as if it were on the road. This allowed us to get a very refined carburetion, similar to the original one.

CDI

- Carburetion adjusting
- ± 20% at min/medium/max
- RPM limiter shifted to 10.000 RPM
- 4 different maps:
 - Curve 0 : original camshaft, original exhaust system
 - Curve 1 : original camshaft, Malossi exhaust system
 - Curve 2 : Malossi camshaft, original exhaust system
 - Curve 3 : Malossi camshaft, Malossi exhaust system



HONDA
SH13

MULTIVAR 2000 MHR
5114192 € 144,20



SPORT SCREEN - dark smoke screen
4514607 (<-2010) € 59,40
4515124 (2011->2014) € 66,00

RACING CLUTCH SPRING SET
for ORIGINAL CLUTCH
and MAXI DELTA CLUTCH
2911326 € 17,00



Power curve HONDA SH 300

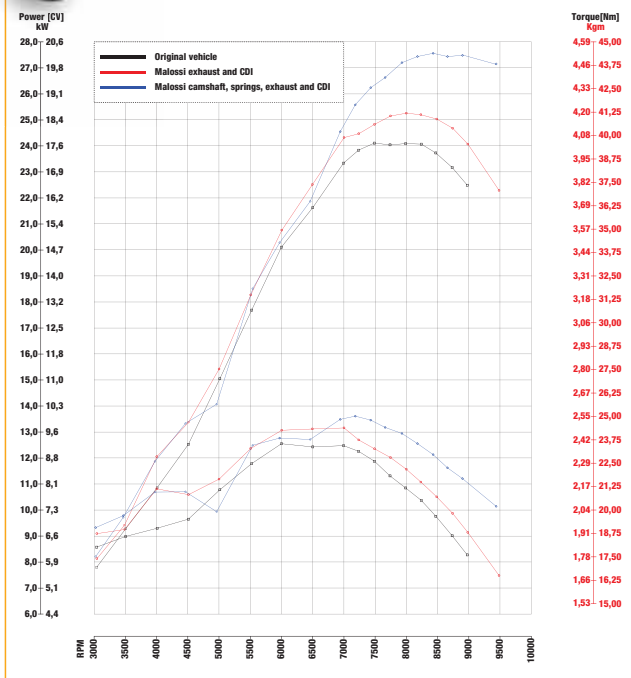

HONDA
SH 300

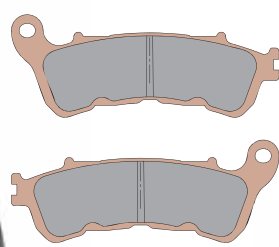

BRAKE PADS MHR SYNT
6215034 € 18,62
front homologated

W BOX Air filter
1415334 € 45,00



TC UNIT O2 controller
lambda emulator
5515734 € 90,00



4 SPRINGS for ENGINE VALVES
2914680 € 13,39
 Exhaust and Intake valve springs made of Si-Cr oil-tempered and annealed steel, designed to operate optimally under increased loads due to increased engine power.

POWER CAM camshaft
5914657 € 216,30



These new camshafts were created by exploiting Malossi experience and technical know-how in designing and building special parts for tourist and sports use. The camshafts were designed with the Cad-Cam system, built with very high precision machinery, and controlled 100% by measuring instruments with precision capability down to a tenth of a micron. These components are true mechanical jewels. The Malossi camshaft was designed and constructed to give your scooter a markedly sporting feel enabling you to easily manoeuvre through town traffic and tackle long distances at high cruising speeds. The considerable increase in torque will boost your acceleration and climbing power in a big way.

New

MULTIVAR 2000
5114730 € 144,20

X K belt
6115277 € 76,50



RX
EXHAUST SYSTEM
3214808 € 380,00



W BOX FILTER
for original air filter
1415336 € 45,00



KAWA J 30

VENTILVAR 2000 half-pulley

6114701B € 44,88



**TC UNIT O₂ controller -
lambda emulator**

5516341B

€ 90,00



**SPORT SCREEN -
dark smoke screen**

4516330B € 61,50

**RACING SPRING SET
for original clutch**

2915089 € 16,20



**ASAKI
300**

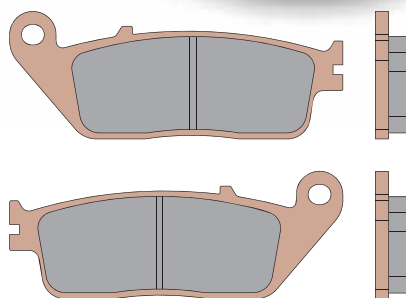

**BRAKE PADS MHR SYNT
front**

6215027 € 16,64

5114730

€ 144,20



New



**TWINS
REAR pair
shock absorber
4614007 € 250,00**

**X K belt
6115277
€ 76,50**



**MAXI WILD LION
exhaust system homologado
3217035 € 479,00**

**W BOX FILTER
for original air filter
1415336 € 45,00**

**KYM
DOWN
35**

**BRAKE PADS MHR SYNT
rear not homologated
6215028 € 20,00**

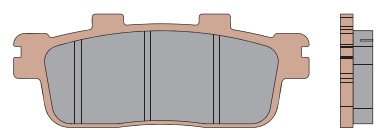

Products to be used exclusively for racing in places specially designed for such activity according to the regulations of the competent sporting authorities. We accept no liability resulting from improper use.

Note: suggested setting example, please check in the following brand/model tables the items suitable for your vehicle.

VENTILVAR 2000
half-pulley
6114701B
€ 44,88



TC UNIT
O₂ controller -
lambda emulator

5516341B
€ 90,00

SPORT SCREEN

screen

4517073

€ 63,00

RACING SPRING SET
for original clutch

2915089

€ 16,20



KYMCO
DOWNTOWN
50

BRAKE PADS MHR SYNT
front homologated

6215037

€ 20,00

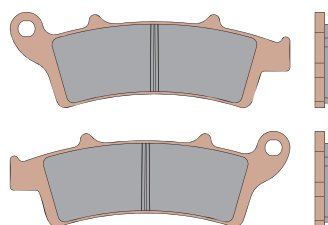

MULTIVAR 2000

5116072

€ 177,16



New

EXHAUST SYSTEM

RX homologated

3216388

€ 428,00



X K belt

6116079

€ 57,00

**XCITER
40**

New

**TC UNIT O₂ controller -
lambda emulator**

5516341B

€ 90,00



**SPORT SCREEN -
dark smoke screen**

4516574

€ 70,00



**RACING
SPRING SET
for original
clutch**

2915089

€ 16,20



TING 00

**Aluminium Complete Cylinder Kit /
POWER CAM Ø 75,5 pin Ø 15
H2O I-TECH 4-stroke**
3116268 <-2013 € 1.085,00

New

MULTIVAR 2000
5111397 € 112,35



TWINS
pair shock absorber
REAR
4613185 € 248,00



EXHAUST SYSTEM
RX Black homologated
3216703 € 502,00



X K belt
6116117 € 34,27

CATALYTIC
CONVERTER
3216704B € 150,00



SECONDARY GEARS
HTQ z 17/49
6712194 € 92,98



VESPA G
125

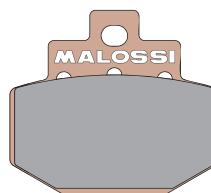

BRAKE PADS MHR SYNT
rear homologated
6215015 € 16,64



TORQUE DRIVER 4 STROKE
6111656 € 123,88

TORSION CONTROLLER
Antifriction fifth wheel
2513210 € 5,72



TC UNIT O2 controller
lambda emulator
5514746 € 90,00



MAXI DELTA CLUTCH
adjustable
automatic clutch
5211821 € 120,42



MAXI CLUTCH BELL
Ø 134
7715898B € 52,00



SPORT SCREEN light smoke screen
4515118 € 67,00



BRAKE PADS MHR SYNT
front homologated
6215013 € 16,50

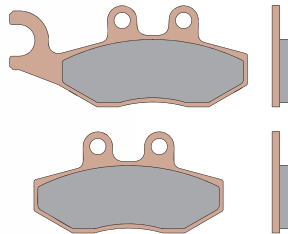

MAXI DELTA SYSTEM
(Clutch BELL Ø 134)
5216918 € 136,00

SHOCK ABSORBER
RS24 front

4614137 <-2013 € 178,50
New 4617076 2014-> € 213,00



WHOOOP DISC brake disc
front - rear
6215330 € 80,00

DOUBLE RED SPONGE
for original filter
1414486 € 7,02



RED CHILLI OIL FILTER
oil filter
0313382 € 7,00



GTS super 5 4T

**Aluminium Complete Cylinder Ø 63
pin Ø 14 I-TECH 4-stroke**

New

3116550 € 530,45

3116669 € 530,45

* see page 410



**TC UNIT O2 controller
lambda emulator**

5515735 (125 cc)

€ 88,00



**RS24 rear
shock absorber**

4617065 € 248,70

New



**RX homologated
EXHAUST SYSTEM**

3216551 € 502,00

New



CATALYTIC CONVERTER

3216715B

(125 cc)

€ 137,00



**RACING SPRING SET
for ORIGINAL CLUTCH**

2912536 (125 cc) € 15,56

2911326 (150 cc) € 17,00



MULTIVAR 2000

5116149 (125 cc) € 112,35



MULTIVAR 2000

5115639 (150 cc)

€ 112,35



**VESPA
PRIMA
125 - 1**

MAXI CLUTCH BELL Ø 125
7715648 (125 cc) € 38,00



SPORT SCREEN
light smoke screen
4516332
€ 75,00

MAXI DELTA CLUTCH
adjustable automatic clutch
5216462 € 120,42



MAXI CLUTCH BELL Ø 134
7715647 € 43,00



MAXI DELTA SYSTEM
(Clutch BELL Ø 134)
5216569 (150 cc) € 135,00

New

X K belt
6116148 (125 cc) € 31,00
6116117 (150 cc) € 34,27

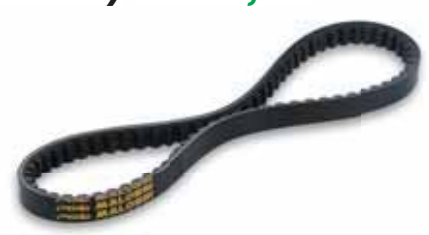

WHOOOP DISC
brake disc front
6212604
€ 76,38



RS24 front
shock absorber
4617076 € 213,00

New



RED CHILLI
OIL FILTER
oil filter
0313382
€ 7,00



PA 3V
PRIMAVERA
150 4T

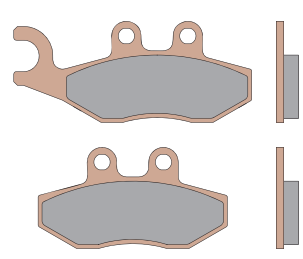

BRAKE PADS MHR SYNT
front not homologated
6215013 € 16,50

TWIN-CYLINDER 4 STROKE 560 cc.**(*) 3113666 - 2008-> 2011 € 690,00****3113687 - 2004-> 2007 € 690,00**

Over 15% increase in power

Specifications

- Bore: Ø 70 mm
- Stroke: 73 mm
- Displacement: 560 cc
- Compression Ratio: 1:12 Max.
- HP @ 7800 RPM
- Twin Cylinder Single Block: Special Al-Si-Cu alloy, hardened and stress relieved
- Cylinder liners: Cermet (Ni-Ca-Sil) coated and machined with extreme precision in our state of the art work cells
- Cross-honed at 110°/130°

(*) Also for vehicles 2004-> 2007 with hydraulic chain tensioner**FORGED PAIR OF PISTONS Ø 66 PIN Ø 15 WITH 3 PISTON RINGS FOR ORIGINAL CYLINDER****3413706 - 2004-> 2011 € 343,20**

Forged Pistons: Special Al-Si-Cu alloy, hardened, shaped crown with valve reliefs, racing design, reinforced and lightened with constant wall thickness.

**MAXI WILD LION****HOMOLOGATED****3214130 - 2008-> 2011 € 683,40****3212721 - 2001-> 2007 € 499,01**

- European homologation
- Elliptical cross-section casing made of stainless steel with laser marked logo
- Carbon end caps
- Silencer system with the addition of sound absorbing mineral fibers, possessing high noise damping and nondegrading qualities.
- Equipped with DB killer
- Stainless steel exhaust tubes from the cylinder or to the silencer.

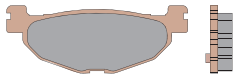
WHOOOP DISC rear brake disc**6213319 € 129,50****BRAKE PADS MHR SYNT****rear homologated - 2004-> 2011****6215026 € 18,72****SPRING PRE-LOAD REGULATION KIT FOR ORIGINAL FORK****2015460 - 2008-> 2011 € 147,46**

Technical features

- Extremely light, completely made of 6000 series aluminium alloy (with magnesium and silicon)
- Range of the preload adjustment plug: -5 / +25 mm
- Laser engraving on the plug with hard oxide coating for an even easier adjustment
- Tube made of 6000 series aluminium alloy (with magnesium and silicon), extremely light, with blue cobalt anodic oxidation

RS24 REAR SHOCK ABSORBER**4613598 € 830,00**

Technical features

- Oil-gas suspension with pressurized nitrogen chamber;
- Hydraulic adjustment in expansion;
- Patented adjustment of the spring pre-load;
- Adjustment of the vehicle setting;
- Stroke 48 mm;
- Adjustment system of the scooter setup, with fit shock absorber.

**T-Max****SUSPENSION BRACKET 25+****1813205 € 196,10**

Shock absorber bracket kit for racing setting. Optimization in bend entrance, reached thanks to 25 mm raising of the vehicle rear part, is the remedy that grants greater stability to vehicle and, moreover, it contrasts the problem of ground impact.

Note: suggested setting example, please check in the following brand/model tables the items suitable for your vehicle.

**Intake valves:**

- Bigger Ø from 25 mm to 26.5 mm
- Special steel for high performance valves
- Hardened stem tip to ensure highest resistance and life of the contact area

Válvula de Escape:

- Bigger Ø from 22 mm to 23.5 mm
- Nickel-based superalloy - NIMONIC 80 - resistant to very high temperatures
- Precipitation hardened material with Rm. 1400 N/mm

4 STROKE VALVE 2715092 € 164,80

Completely refaced valve, valve stem surface with hard chrome coating, valve surface finish, isotropic finishing.

**DOUBLE POWER CAMME****5913783 € 790,00**

Malossi's Double Power Camms are fine-tuned to generate an optimum and progressive power increase if matched with original cylinder or an exponential increase in power if matched with Malossi's 560 cc big bore twin cylinder set.

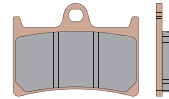
MHR SCREEN**4515361 - 2001-> 2007 € 63,00****4514012 - 2008-> 2011 € 63,00****HOSE KIT (front/rear)****for MHR BRAKE (AERONAUTICAL)****2214135 - 2008-> 2011 € 180,00****2213103 - 2004-> 2007 € 175,00****BRAKE PADS MHR SYNT front homologated****2004-> 2007****6215029 € 17,16****2008-> 2011****6215022 € 17,68****WHOOOP DISC COUPLE front brake disc****6213715 - 2008-> 2011 € 274,00****6216320E - 2004-> 2007 € 237,50**

The "WHOOOP DISC" paired with Malossi BRAKE PADS guarantee a progressive and secure braking even under extreme conditions.

MAX 500

RED CHILLI OIL FILTER**0313639 € 7,64****Technical Characteristics**

- Quality of the filtering media, unalterable in time, and insensitive to rapid temperature changes starting at 20°C below zero to the most elevated operational temperatures.
- Ability to filter infinitely small metallic particles and trap a greater quantity of harmful larger contaminants, in virtue of the special micro-porosity filtering media itself and its high capacity.

**W BOX FILTER****1413703 - 2001-> 2007 € 49,00****1414213 - 2008-> 2011 € 49,00****Technical Characteristics**

- High air flow
- Multilayer long fibre cotton gauze, oiled, and sandwiched between two epoxy-coated aluminium wire screens. Encased in a polyurethane frame, 30 ShA, insuring an excellent seal
- Washable and reusable

**V FILTER****0414614 € 41,36****Technical Characteristics**

- High air flow
- Multilayer long fibre cotton gauze, non-oiled, and sandwiched between two epoxy-coated aluminium wire screens. Encased in a polyurethane frame, 30 Kg/m3 adhesive based, insuring an excellent seal
- Washable and reusable



POWER TRANSMISSION MHR z 26/40**6714757 € 265,00**

HTQ Z 26/40 pinion and ring gear pair with lengthened gear ratio, Malossi Morse lightened, narrower, frictionless racing chain. This system completely replaces the original primary gears (25-tooth pinion and 41-tooth ring gear) with a 26-tooth drive pinion and a 40-tooth driven ring gear, thus providing a 7% longer ratio. Besides providing this longer ratio, these gears are narrower, as to fit the new Malossi Morse racing chain, which is frictionless and without friction springs, thus lighter, more sliding and with higher resistance and long life compared to the original one, since "you can't break what is missing".

**HTQ Z 26/40 pinion and ring gear pair**

- 1) Toothed ring gear pair with narrower walls, consisting of one 26-tooth drive pinion and one 40-tooth driven ring gear, made in Cr Ni Mo 5 alloy steel, tempered and case-hardened, manufactured basing on Malossi design with high precision machine tools.
- 2) Tooth profile designed for maximum resistance and minimum noise.
- 3) Tooth contact surfaces provided with maximum finish to ensure very long life and operating reliability.
- 4) High-standard inspections on each component, from raw materials to the finished product, ready for sale.

Malossi Morse Racing chain

Narrower chain, designed to eliminate the lateral friction of the original chain.



NB: we recommend not to modify Malossi Morse racing chain, art. 6114474B, in order to fit the original or other manufacturers' pinion and ring gear pair. Malossi does not assume any responsibility, thus won't recognize any warranty in case of damage.

**POWER TRANSMISSION SPORT - z 26/40 for original chain****6714418 € 148,00**

Gear sets which lengthen the pitch of about 7%. This Sport version must be used only with the original chain since Malossi racing chain is narrower and it doesn't accept original or similar ring gears.

**DISK SET
for original clutch
5215401 € 89,00**
**FORCE MASTER 2 - electronic controller (injection)****5514756 - 2008-> 2011 € 255,84****5514854 - 2004-> 2007 € 255,84**

Force Master 2 is the innovative CDI which allows to change the injection in order to fit perfectly the new Malossi 4-stroke cylinder kit.

This CDI has been scheduled with 4 different maps so as to be coupled perfectly with your vehicle whatever its setting is.

Maps were scheduled at the static test bench, thus simulating the real load of the engine, as if it were on the road. This allowed us to get a very refined carburetion, similar to the original one!

Technical features

- Carburetion adjusting
- $\pm 20\%$ at min/medium/max
- RPM limiter shifted to 9500 RPM
- 4 different maps
 - Curve 0 : original twin-cylinder, original camshaft, Malossi exhaust system, Malossi air filter
 - Curve 1 : Malossi pistons $\varnothing 66$, Malossi camshaft, Malossi exhaust system, Malossi air filter
 - Curve 2 : Malossi twin-cylinder $\varnothing 70$, original camshaft, Malossi exhaust system, Malossi air filter
 - Curve 3 : Malossi twin-cylinder $\varnothing 70$, Malossi camshaft, Malossi exhaust system, Malossi air filter

**TC UNIT O₂ controller - lambda emulator****5514747 - 2004-> 2011 € 84,00**

We suggest to use the O₂ controller to further optimize both carburetion and performances in transistors. In latest generation motorcycles, thanks to lambda sensor, the CDI can rectify the fuel quantity to be injected in order to reach a constant carburetion even in Closed Loop area. The O₂ controller permits to totally control the carburetion as to obtain the best air/fuel ratio. Malossi Lambda emulator is a device able to simulate signals from lambda sensor which original CDI is expected to receive. In this way, original lambda sensor is used to obtain best carburetion without the original CDI noticing failures or mistakes.



Note: suggested setting example, please check in the following brand/model tables the items suitable for your vehicle.

Transmission system

OVER RANGE - 6114885 € 549,78

2004-> 2011

X K BELT
6114674 € 105,76



MULTIVAR 2000 MHR NEXT

5114855 - 2004-> 2011 € 177,16

- Further widened gear range (especially short gear)
- Improved shifting consistency
- Hard anodized - black
- Modified roller guides to allow greater operational linearity while maintaining maximum power
- Case-hardened and ground machined steel sliding bushing
- Hardened, ground machined, chromed steel hub- New one-piece rollers with a better performing compound
- Supplied with two different roller sets and two shims in order to change the number of revolutions of the gear curve of your vehicle perfectly adjusting its speed and acceleration

VENTILVAR 2000

6113806B € 64,88

The fixed half-pulley features a diamond finish of the belts side pulley surface and a redesigned working angle to further increase the gearing range. This component completes the Multivar and renders it unparallelled!

TORQUE DRIVER

6113495 € 202,98

Mobile driven split pulley.

The spiral section is made of the finest steel; nitride surface hardened, the pulley is made of diamond finished aluminium, riveted to guarantee the highest rigidity.

The spiral section's special form was fine tuned to maintain constant engine speed at peak horsepower.



TORSION CONTROLLER

2514227 € 45,00

Antifriction fifth wheel for variator contrast spring.

VARIABLE-SPEED DRIVE

ADJUSTER SPRING € 15,16

Silicon-steel springs with high carbon content, heat-treated, dynamically balanced, kiln painted and designed and calculated for each specific application.

2914023.R0



+ 30 %

2912772.W0



+ 13 %

2914024.Y0



+ 7 %

2914401.G0



- 39 %

Rigidity
compared to the original

RACING CLUTCH SPRING

2913327 € 18,39

Pre-hardened carbon steel springs for original clutch, with high yield strength, galvanically treated for extended protection.

The different coloring indicates the load capacity of each spring series.

The spring kit permits up to a 500 rpm clutch engagement with 150 rpm increments per spring type.



T-Max 500



OVER RANGE - 6115472 € 493,68



TORQUE DRIVER

6115289

€ 209,10



The mobile driven split pulley comes from our racing department's many years of experience, and is manufactured with the best possible special nitrided steels in order to ensure a long life.

This component called Torque Driver for its specific function of determining the exact shifting moment, was calculated to give the vehicle the maximum possible acceleration in connection with the specific power of any single engine. The spiral's peculiar shape was studied to fix the RPMs on the point of maximum power.

Products to be used exclusively for racing in places specially designed for such activity according to the regulations of the competent sporting authorities. We accept no liability resulting from improper use.



T-Max

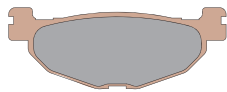

BRAKE PADS MHR SYNT rear homologated
6215030 € 18,75



VENTILVAR 2000

6115285B € 64,88

New fixed half-pulley, larger external diameter (186 mm, +3 mm compared to the original one), redesigned working angle (13°) and diamond finish of the belt-side pulley surface to further increase the gearing range! This component completes the Multivar and renders it unparalleled! Suitable even to original variator.

SPRING PRE-LOAD REGULATION KIT FOR ORIGINAL FORK

2015460 - 2012->2014

€ 147,46

Technical features

- Extremely light, completely made of 6000 series aluminium alloy (with magnesium and silicon)
- Range of the preload adjustment plug: -5 / +25 mm
- Laser engraving on the plug with hard oxide coating for an even easier adjustment
- Tube made of 6000 series aluminium alloy (with magnesium and silicon), extremely light, with blue cobalt anodic oxidation



Note: suggested setting example, please check in the following brand/model tables the items suitable for your vehicle.

MULTIVAR 2000 MHR**5115470 € 188,49**

- Widened gear range (especially short gear).
- Improved shifting consistency.
- Hard anodized black.
- External diamond fins.
- Modified roller guides to allow greater operational linearity while maintaining maximum power.
- Case-hardened and ground machined steel sliding bushing.
- Hardened, ground machined, chromed steel hub.
- New one-piece rollers with a better performing compound.
- Supplied with two different roller sets in order to change the number of revolutions of the gear curve of your vehicle perfectly adjusting its speed and acceleration.
- Equipped with sliders.
- One shim included into the kit

**MHR SCREEN****4516328 € 67,00****RACING SPRING SET****2915602 € 18,39**

Pre-hardened carbon steel springs for original clutch, with high yield strength, galvanically treated for extended protection.

The different coloring indicates the load capacity of each spring series.

The spring kit permits up to a 500 rpm clutch engagement with 150 rpm increments per spring type.

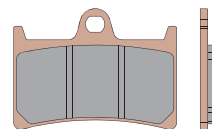
**HOSE KIT (front/rear)
FOR MHR BRAKE
(AERONAUTICAL)****2215529 € 191,00**

**BRAKE PADS
MHR SYNT front**
6215022 € 17,68

2914023.R0**+ 30 %**

Rigidity
compared to the original

2912772.W0**+ 13 %****2914024.Y0****+ 7 %****2914401.G0****- 39 %****VARIABLE-SPEED DRIVE ADJUSTER SPRING****€ 15,16**

Silicon-steel springs with high carbon content, heattreated, dynamically balanced, kiln painted and designed and calculated for each specific application.

**WHOOOP DISC COUPLE
front brake disc****6216320E € 237,50**

The "WHOOOP DISC" paired with Malossi BRAKE PADS guarantee a progressive and secure braking even under extreme conditions.

x 530

RS24 REAR SHOCK ABSORBER**4613598 € 830,00**

Technical features

- Oil-gas suspension with pressurized nitrogen chamber;
- Hydraulic adjustment in expansion;
- Patented adjustment of the spring pre-load;
- Adjustment of the vehicle setting;
- Stroke 48 mm;
- Adjustment system of the scooter setup, with fit shock absorber.

**TORSION CONTROLLER****2514227****€ 45,00**

Antifriction fifth wheel for variator contrast spring.

**New****MAXI WILD LION HOMOLOGATED****3216407 € 670,00**

- European homologation
- Elliptical cross-section casing made of aluminium with black anodized finish and laser marked logo
- Carbon end caps
- Silencer system with the addition of sound absorbing mineral fibers, possessing high noise damping and nondegrading qualities.
- Equipped with DB killer
- Stainless steel exhaust tubes from the cylinder or to the silencer.

**RED CHILLI OIL FILTER****0313639****€ 7,64**

Technical Characteristics

- Quality of the filtering media, unalterable in time, and insensitive to rapid temperature changes starting at 20°C below zero to the most elevated operational temperatures.
- Ability to filter infinitely small metallic particles and trap a greater quantity of harmful larger contaminants, in virtue of the special micro-porosity filtering media itself and its high capacity.

W BOX FILTER**1414213****€ 49,00**

Technical Characteristics

- High air flow
- Multilayer long fibre cotton gauze, oiled, and sandwiched between two epoxy-coated aluminium wire screens. Encased in a polyurethane frame, 30 ShA, insuring an excellent seal
- Washable and reusable

V FILTER**0415216****€ 42,57**

Technical Characteristics

- High air flow
- Multilayer long fibre cotton gauze, non-oiled, and sandwiched between two epoxy-coated aluminium wire screens. Encased in a polyurethane frame, 30 Kg/m³ adhesive based, insuring an excellent seal
- Washable and reusable

Note: suggested setting example, please check in the following brand/model tables the items suitable for your vehicle.**T-Max**

**TC Unit O₂ controller
lambda emulator**
5515720 € 84,00

We suggest to use the O₂ controller to further optimize both carburetion and performances in transistors. In latest generation motorcycles, thanks to lambda sensor, the CDI can rectify the fuel quantity to be injected in order to reach a constant carburetion even in Closed Loop area. The O₂ controller permits to totally control the carburetion as to obtain the best air/fuel ratio.

Malossi Lambda emulator is a device able to simulate signals from lambda sensor which original CDI is expected to receive.

In this way, original lambda sensor is used to obtain best carburetion without the original CDI noticing failures or mistakes.

DOUBLE POWER CAMME
5915981 € 826,00

Malossi's Double Power Cams are fine-tuned to generate an optimum and progressive power increase if matched with original cylinder or an exponential increase in power if matched with Malossi's 560 cc big bore twin cylinder set.

DISK SET for original clutch
5215608 € 104,00



**MHR intake horns PAIR
for ORIGINAL THROTTLE BODY**
0516195 € 145,00

New



**WHOOOP DISC
rear brake disc**
6215594 € 129,50



X K BELT
6116011 € 127,88



MAX 530

**Force Master 3
electronic controller (injection)**
5515730 € 298,00



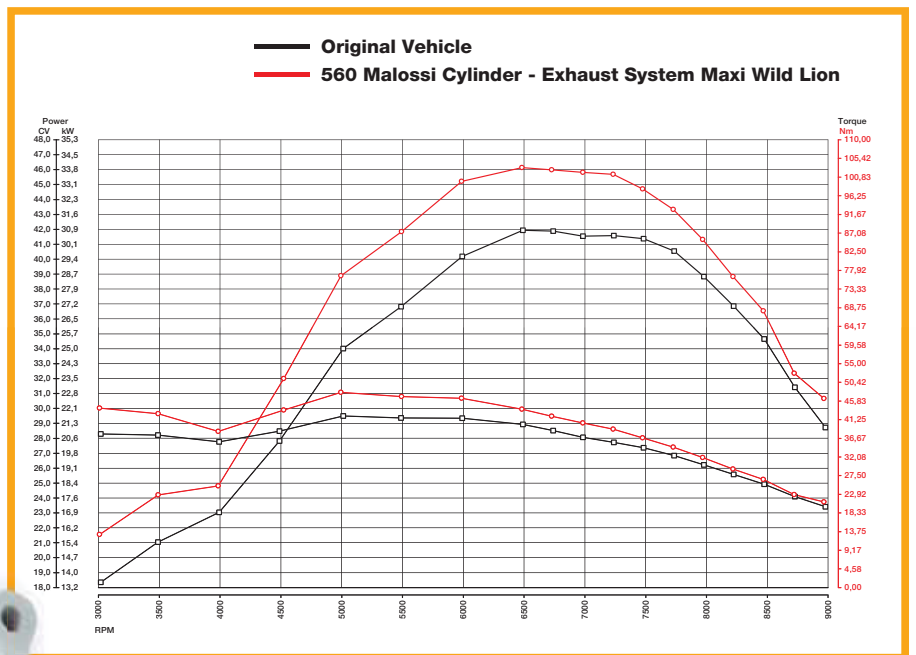

Bi- Cilindro 4-stroke 560 cc.

3115423 € 690,00

- Increase in power
- Extreme reliability.
- "Made in Italy" Technology.
- Designed and manufactured in the Calderara di Reno, Italy facility
- Malossi's engineering staff gave special attention in all phases, from design to manufacturing, as with all the products displaying this trademark.

Yamaha's clean design single block, twin cylinder was modified by Malossi with significant changes and updates that allowed a substantial bore increase without compromising the original mechanical and thermal integrity. Of particular interest are the pistons, which are forged using a special alloy, analysed, and designed to withstand the working stresses due to extended use. Nothing was left to chance, from the gaskets to the lightweight, taper bore, high alloy steel gudgeon pin to the chromed plated and gas nitride steel piston rings. Every detail is a precious contribution in creating a very exclusive cylinder/piston set: a product for a discerning and well-informed customer!

Specifications

- Bore: Ø 70 mm
- Stroke: 73 mm
- Displacement: 560 cc
- Compression Ratio: 1:12 Max.
- HP @ 7800 RPM
- Twin Cylinder Single Block: Special Al-Si-Cu alloy, hardened and stress relieved
- Cylinder liners: Cermetal (Ni-Ca-Sil) coated and machined with extreme precision in our state of the art work cells
- Cross-honed at 110°/130°

- Ø 70 forged pistons, pin 15 with 3 piston rings: special Al-Si-Cu alloy, hardened, shaped crown with valve reliefs, racing design, reinforced and lightened with constant wall thickness.

Piston Rings (3):

- 1st - Compression Ring: Chrome plated steel.
- 2nd - Intermediate Ring: Phosphate coated steel.
- 3rd - Oil Control Ring: 3-piece oil ring, (chrome plated steel rails, plus spring).

Note: suggested setting example, please check in the following brand/model tables the items suitable for your vehicle.

1616722 € 750,00



More power for the T-Max



The most powerful engines require an adequate and constant supply of fuel. Increasing the performance of the Yamaha T-Max, drawing from the extremely complete Malossi catalogue, has made it essential to build a specific throttle body able to ensure a performance that is unthinkable for the standard unit.

Made of black anodized 7975-T6 aluminium, the MHR throttle body has been designed specifically to achieve maximum efficiency in combination with the 560cc Malossi twin cylinder kit and with the Double PowerCam, providing the right intake to the engine in this configuration.

The inner diameter of the throttle body is widened to 38mm, while its length remains identical to the original so that it can be placed without difficulty in its standard position between the head and the airbox.

Its inner ducts are cylindrical near the horns, to become progressively oval-shaped in correspondence of the butterfly valve. Thanks to this variation of internal shape, the fresh gases are pushed with more energy towards the head which, featuring two intake valves, requires a significant width, offered by the oval section that continues to the end of the manifold.

The two manifolds supplied with the kit are oversized and can be installed only on a worked head without requiring further modifications. The specific horns for the MHR throttle body are calculated and optimized to achieve the maximum yield from the oval sections of the bodies, exploiting the perfect harmonization of the entire duct.

Use	Racing
Level of compatible elaboration	Twin cylinder 4-stroke 560 cc. 3115423
 HARD Head working	 Double Power Camme 5915981
	

T-Max 530





MALOSSI

Maxi Scooter

125 → 800 4T

with ENGINE 

APRILIA

ATLANTIC -
Arrecife

ATLANTIC

ATLANTIC -
ArrecifeATLANTIC SPRINT
- Arrecife

(PIAGGIO M234M)

(PIAGGIO M237M)

(PIAGGIO M348M)

125 4T

LC

200 4T

LC

250 4T

LC

400 4T

LC

	CYLINDER 4 STROKE ALUMINIUM	3113955 € 335,00 Ø 75,5	3113955 € 335,00 Ø 75,5	3113928 € 335,00 Ø 74	-
	CYLINDER I-TECH ALUMINIUM EQUIPPED WITH CDI	-	-	-	-
	POWER CAM CAMSHAFT	*62*	5911962 € 218,53	-	5913846 € 227,63
	HEAD V4 HEAD FOR ORIGINAL CYLINDER / MALOSSİ	*01*	*01*	3813273 € 475,00	-
	CYLINDER + V4 HEAD ALUMINIUM	-	-	3113927 € 745,00 Ø 74	-
	CYLINDER + V4 HEAD + POWER CAM ALUMINIUM Ø 75,5	3116208 € 895,00	3116208 € 895,00	-	-
	4 STROKE VALVE FOR ENGINE VALVES SET	2714047 € 118,53	2714047 € 118,53	2714047 € 118,53	-
	SPRINGS FOR ENGINE VALVES	2912834 € 21,54	2912834 € 21,54	2912834 € 21,54	2913068 € 22,74
	CRANKSHAFT RHQ	5312853 € 380,00	5312896 € 380,00	-	-
	IGNITION CONTROLLER DIGITRONIC FOR VEHICLES WITHOUT IMMOBILIZER	5512524 € 170,46	5512524 € 170,46	-	-
	IGNITION CONTROLLER DIGITRONIC FOR VEHICLES WITH IMMOBILIZER	5512341 € 170,46	5512341 € 170,46	-	-
	FORCE MASTER INJECTION CONTROLLER	-	-	5515724 € 255,84	-
	TC UNIT O2 controller LAMBDA EMULATOR	-	-	-	-
	MULTIVAR 2000 VARIATOR MULTIVAR 2000 MHR	5111397 € 112,35	5111885 € 112,35	5111885 € 112,35	5114260 € 173,04
	X SPECIAL BELT BELT X K BELT BELT	6116117 € 34,27	6115666 € 46,92	6113027 € 59,12	6115125 € 88,54
	HTRoll ROLLERS FOR MULTIVAR 2000 / MHR	6611095.G0 € 13,64 gr.09,5	6611095.R0 € 13,64 gr.14	6611095.T0 € 13,64 gr.15	6613554.B0 € 26,00 gr.15
	HTRoll ROLLERS FOR ORIGINAL VARIATOR	-	6613697.I0 € 18,00 gr.11	6613697.I0 € 18,00 gr.11	-
	VENTILVAR 2000 FIXED HALF-PULLEY	-	-	-	-
	VARIABLE-SPEED DRIVE ADJUSTER SPRING FOR VARIATOR	PG.445	PG.445	PG.445	PG.445
	TORSION CONTROLLER ANTIFRICTION FIFTH WHEEL	2513210 € 5,72	2513210 € 5,72	2513210 € 5,72	-
	TORQUE DRIVER MOBILE DRIVEN SPLIT PULLEY	6111656 € 123,88	6112563 2003-> € 197,30 6111656 <-2002 € 123,88	6112563 € 197,30	-
	OVER RANGE TRANSMISSION KIT	-	-	-	-
	MAXI FLY CLUTCH NOT ADJUSTABLE CLUTCH	-	-	-	5212813 € 146,14
	MAXI DELTA CLUTCH ADJUSTABLE CLUTCH	5211821 € 120,42	5211821 € 120,42	5211821 € 120,42	-
	MAXI CLUTCH BELL CLUTCH BELL (SMOOTH RING)	-	-	-	-
	MAXI WING CLUTCH BELL CLUTCH BELL (FINNED RING)	7715898B € 52,00 Ø 134	7715898B € 52,00 Ø 134	7715898B € 52,00 Ø 134	7715579B € 49,00 Ø 160
	MAXI FLY SYSTEM CLUTCH BELL + NOT ADJUSTABLE CLUTCH	-	-	-	5216202 € 149,94 Ø 160
	MAXI DELTA SYSTEM CLUTCH BELL + ADJUSTABLE CLUTCH	5216918 € 136,00 Ø 134	5216918 € 136,00 Ø 134	5216918 € 136,00 Ø 134	-
	SPRINGS FOR MAXI FLY CLUTCH	-	-	-	2913137 € 20,99
	SPRINGS FOR MAXI DELTA CLUTCH	2911326 € 17,00	2911326 € 17,00	2911326 € 17,00	-
	SPRINGS FOR ORIGINAL CLUTCH	2911326 € 17,00	2911326 € 17,00	2911326 € 17,00	2912779 € 21,00

Products to be used exclusively for racing in places specially designed for such activity according to the regulations of the competent sporting authorities. We accept no liability resulting from improper use.



01 - TO COUPLE ONLY with MALOSSİ CYLINDERS: 3813273 € 475,00

62 - TO COUPLE ONLY with MALOSSİ CYLINDERS : 5911962 € 218,53

PG - SPECIFICATIONS on the PAGE indicated in the TITLE of the LINE

APRILIA

59

ATLANTIC		ATLANTIC SPRINT - Arrecife		HABANA		LEONARDO		LEONARDO		LEONARDO		LEONARDO		MOJITO	
		(PIAGGIO M273M)													
500 4T	LC	500 4T	LC	125 4T		125 4T	LC	150 4T	LC	250 4T	LC	300 4T	LC	125 4T	
-	-	-	-	31 9518		31 9990		31 9990		31 9578		31 9578		31 9518	
				€ 295,92	Ø 60	€ 292,98	Ø 67	€ 292,98	Ø 67	€ 363,37	Ø 74	€ 363,37	Ø 74	€ 295,92	Ø 60
-	-	-	-	-	-	-	-	-	-	-	-	-	-	-	-
5913846		5913846		-	-	-	-	5911229		5911517		5911517		-	-
€ 227,63		€ 227,63						€ 100,54		€ 196,11		€ 196,11			
-	-	-	-	-	-	-	-	-	-	-	-	-	-	-	-
-	-	-	-	-	-	-	-	-	-	-	-	-	-	-	-
-	-	-	-	-	-	-	-	-	-	2711824		2711824		-	-
										€ 77,38		€ 77,38			
2913068		2913068		-	-	-	-	-	-	-	-	-	-	-	-
€ 22,74		€ 22,74													
-	-	-	-	-	-	-	-	-	-	-	-	-	-	-	-
-	-	-	-	-	-	-	-	-	-	-	-	-	-	-	-
-	-	-	-	-	-	-	-	-	-	-	-	-	-	-	-
5114260 (8 rollers) € 173,04		5114260		5111154		5111257		5111257		5111225		5111225		5111154	
5111808 (6 rollers) € 172,79		€ 173,04		€ 75,99		€ 116,80		€ 116,80		€ 121,97		€ 121,97		€ 75,99	
-	-	-	-	-	-	6116215		6116215		6116094		6116094		-	-
						€ 31,00		€ 31,00		€ 40,00		€ 40,00			
6613554.B0 gr.15 (8) € 26,00		6613554.B0		66 9420.K0		6611095.DO		6611095.F0		66 9919.G0		66 9919.G0		66 9420.K0	
6613968.A0 gr.20 (6) € 17,81		€ 26,00 gr.15		€ 10,00 gr.12		€ 13,64 gr.08		€ 13,64 gr.09		€ 22,15 gr.11		€ 22,15 gr.11		€ 10,00 gr.12	
6613968.E0		-		6611531.H0		6611095.E0		6611095.G0		66 9919.L0		66 9919.M0		6611531.H0	
€ 17,81 gr.28 (6 rollers)				€ 9,41 gr.12		€ 13,64 gr.08,5		€ 13,64 gr.09,5		€ 22,15 gr.14		€ 22,15 gr.14,5		€ 9,41 gr.12	
-	-	-	-	-	-	-	-	-	-	6111102B		6111102B		-	-
										€ 36,72		€ 36,72			
PG.445		PG.445		-	-	2911266.Y0 *PG*		2911266.Y0 *PG*		PG.445		29 9975.Y0 *PG*		-	-
						€ 10,71		€ 10,71				€ 10,71			
-	-	-	-	-	-	-	-	-	-	-	-	-	-	-	-
-	-	-	-	-	-	6111658		6111658		6111763		6111763		-	-
						€ 108,00		€ 108,00		€ 159,12		€ 159,12			
-	-	-	-	-	-	-	-	-	-	-	-	-	-	-	-
5212813		5212813		-	-	5212539		5212539		-		-		-	-
€ 146,14		€ 146,14				€ 70,37 Ø 134		€ 70,37 Ø 134							
-	-	-	-	-	-	5212492		5212492		5211468		5211835		-	-
						€ 104,00 Ø 134		€ 104,00 Ø 134		€ 129,23		€ 128,41			
-	-	-	-	-	-	-	-	-	-	7713368		7713369		-	-
										€ 59,00 Ø 135		€ 56,50 Ø 145			
7715579B		7715579B		-	-	-		-		-		-		-	-
€ 49,00 Ø 160		€ 49,00 Ø 160													
5216202		5216202		-	-	-		-		-		-		-	-
€ 149,94 Ø 160		€ 149,94 Ø 160													
-	-	-	-	-	-	-	-	-	-	-	-	5214721		-	-
												€ 137,70 Ø 145			
2913137		2913137		-	-	29 9605		29 9605		-		-		-	-
€ 20,99		€ 20,99				€ 16,20		€ 16,20							
-	-	-	-	-	-	29 9605		29 9605		2911326		2911848		-	-
						€ 16,20		€ 16,20		€ 17,00		€ 17,00			
2912779 (5 masses) € 21,00		2912779		-	-	2911326		2911326		2911325		2911848		-	-
2911326 (3 masses) € 15,94		€ 21,00				€ 17,00		€ 17,00		€ 17,24		€ 17,00			

MAXI SCOOTER 125 → 800 4T



MALOSSI

Maxi Scooter

125 → 800 4T

with ENGINE 

APRILIA

ATLANTIC -
Arrecife

ATLANTIC

ATLANTIC -
ArrecifeATLANTIC SPRINT
- Arrecife

































(PIAGGIO M234M)

(PIAGGIO M237M)

(PIAGGIO M348M)

 CHECK "TYPE" SPECIFICATION (HOMOLOGATION MARK).

125 4T LC 200 4T LC 250 4T LC 400 4T LC



	CLUTCH DISK SET FOR ORIGINAL CLUTCH		-	-	-	-
	MAXI WILD LION   HOMOLOGATED EXHAUST SYSTEM		-	-	-	3214374 *69* € 476,34
	RX   HOMOLOGATED EXHAUST SYSTEM		-	-	-	-
	RED CHILLI OIL OIL FILTER		0313382 € 7,00	0313382 € 7,00	0313382 € 7,00	0313383 € 7,42
	RED SPONGE FOR ORIGINAL AIR BOX		1412129 € 5,10	1412129 € 5,10	1412129 € 5,10	1412129 € 5,10
	DOUBLE RED SPONGE FOR ORIGINAL AIR BOX		1414496 € 7,35	1414496 € 7,35	1414496 € 7,35	1414496 € 7,35
	W BOX FOR ORIGINAL AIR BOX		-	-	-	-
	V FILTER VARIATOR AIR FILTER RIGHT SIDE		-	-	-	-
	POWER TRASMISSION		-	-	-	-
	GEARS HTQ PRIMARY		-	-	-	-
	GEARS HTQ SECONDARY		6712067 € 69,96 z 15/41	6711860 € 60,41 z 16/42	-	-
	SPORT SCREEN SCREEN		-	-	-	-
	MHR SCREEN SCREEN		-	-	-	-
	HOSE KIT FOR BRAKE		-	-	-	-
	BRAKE PADS FRONT ORGANIC BRAKE PADS		6216938 € 14,00 2003-> 05	6216938 € 14,00 2003-> 05	6216938 € 14,00 2003->	-
	BRAKE PADS MHR FRONT ORGANIC BRAKE PADS		-	-	-	-
	BRAKE PADS MHR SYNT FRONT SINTERED BRAKE PADS		6215037 € 20,00 2003-> 05	6215037 € 20,00 2003-> 05	6215037 € 20,00 2003->	-
	BRAKE PADS REAR ORGANIC BRAKE PADS		-	-	-	-
	BRAKE PADS MHR REAR ORGANIC BRAKE PADS		-	-	-	-
	BRAKE PADS MHR SYNT REAR SINTERED BRAKE PADS		-	-	6215019 € 16,64	6215019 € 16,64
	BRAKE POWER REAR BRAKE SHOES		-	-	-	-
	DISC / WHOOP DISC / PAIR WHOOP FRONT BRAKE DISC		-	-	-	-
	DISC / WHOOP DISC REAR BRAKE DISC		-	-	-	-
	TWINS MAXI SUSPENSIONS REAR PAIR SHOCK ABSORBER		-	-	-	-
	RS3 - RS1 REAR SHOCK ABSORBER		-	-	-	-
	RS24 REAR SHOCK ABSORBER		-	-	-	-
	RS24 FRONT SHOCK ABSORBER		-	-	-	-
	RS24 FRONT + REAR		-	-	-	-
	F32S FORK STEMS Ø 32		-	-	-	-
	F37R FORK STEMS Ø 37		-	-	-	-

69 - ONLY homologated SILENCER

76 - ALSO AVAILABLE : HOMOLOGATED, 6215008 € 11,96 1995 > 96 - 6215009 € 14,50 1997 > 1998

APRILIA

61

ATLANTIC	ATLANTIC SPRINT - Arrecife	HABANA	LEONARDO	LEONARDO	LEONARDO	LEONARDO	MOJITO
	(PIAGGIO M273M)						
500 4T LC	500 4T LC	125 4T 	125 4T LC	150 4T LC	250 4T LC	300 4T LC	125 4T 
-	-	-	-	-	-	-	-
3214374 *69* € 476,34	-	-	-	-	-	-	-
-	-	-	-	-	-	-	-
0313383 € 7,42	0313383 € 7,42	0313381 € 3,80	0313384 € 4,57	0313384 € 4,57	-	-	0313381 € 3,80
-	1412129 € 5,10	-	1411408 € 3,53	1411408 € 3,53	-	-	-
-	1414496 € 7,35	-	-	-	-	-	-
-	-	-	-	-	-	-	-
-	-	-	-	-	-	-	-
-	-	-	6711360 € 76,72 z 20/46	6711360 € 76,72 z 20/46	-	-	-
-	-	-	-	-	67 9974 € 90,27 z 17/37	-	-
-	-	-	-	-	-	-	-
-	6216938 € 14,00 2005->	-	6215043 € 5,80 1995->96	-	6215048 € 8,32 1999->	-	-
-	-	-	62 9083 € 6,20 1995->96	-	62 9098 € 8,10 1999->	-	-
-	6215037 € 20,00 2005->	6211649 € 15,00 1999->	6211649 *76* € 15,00 1999->	6211649 1999-> € 15,00 6215009 1998 € 14,50	6215031 € 17,16 1999->	-	6211649 € 15,00 1999->
-	-	-	6215042 € 5,72 1995->98	6215042 € 5,72 1998	-	-	-
-	-	-	6215080 € 6,00 1995->98	6215080 € 6,00 1998	-	-	-
-	6215019 € 16,64	-	6211649 1999-> € 15,00 6215007 1995->98 € 11,96	6211649 1999-> € 15,00 6215007 1998 € 11,96	6215019 € 16,64 1999->	-	-
-	-	6215328 € 18,39 1999->	-	-	-	-	6215328 € 18,39 1999->
6212350 € 85,00 2002	-	-	-	-	-	-	-
-	-	-	-	-	-	-	-
-	-	-	-	-	-	-	-
-	-	-	-	-	-	-	-
-	-	-	-	-	-	-	-
-	-	-	-	-	-	-	-
-	-	-	-	-	-	-	-
-	-	-	-	-	-	-	-
-	-	-	-	-	-	-	-
-	-	-	-	-	-	-	-
-	-	-	-	-	-	-	-
-	-	-	-	-	-	-	-
-	-	-	-	-	-	-	-
-	-	-	-	-	-	-	-
-	-	-	-	-	-	-	-
-	-	-	-	-	-	-	-
-	-	-	-	-	-	-	-

MAXI SCOOTER 125 → 800 4T



MALOSSI

Maxi Scooter

125 → 800 4T

with ENGINE 

APRILIA

MOJITO RY

SCARABEO

SCARABEO

SCARABEO Light
euro 3

(LEADER)

(PIAGGIO)

(ROTAX)

(APRILIA BA03)

125 4T



125 4T

LC

125 4T

LC

125 4T

LC

	CYLINDER 4 STROKE ALUMINIUM	3111393 € 302,60 Ø 70	3113955 € 335,00 Ø 75,5	31 9990 € 292,98 Ø 67	-
	CYLINDER I-TECH ALUMINIUM EQUIPPED WITH CDI	-	-	-	-
	POWER CAM CAMSHAFT	-	*62*	-	-
	HEAD V4 HEAD FOR ORIGINAL CYLINDER / MALOSSİ	-	*01*	-	-
	CYLINDER + V4 HEAD ALUMINIUM	-	-	-	-
	CYLINDER + V4 HEAD + POWER CAM ALUMINIUM Ø 75,5	-	3116208 € 895,00	-	-
	4 STROKE VALVE FOR ENGINE VALVES SET	-	2714047 € 118,53	-	-
	SPRINGS FOR ENGINE VALVES	-	2912834 € 21,54	-	-
	CRANKSHAFT RHQ	-	5312853 € 380,00	-	-
	IGNITION CONTROLLER DIGITRONIC FOR VEHICLES WITHOUT IMMOBILIZER	-	5512524 € 170,46	-	-
	IGNITION CONTROLLER DIGITRONIC FOR VEHICLES WITH IMMOBILIZER	-	5512341 € 170,46	-	-
	FORCE MASTER INJECTION CONTROLLER	-	-	-	-
	TC UNIT O2 controller LAMBDA EMULATOR	-	-	-	-
	MULTIVAR 2000 VARIATOR MULTIVAR 2000 MHR	5111397 € 112,35	5111397 € 112,35	5111257 € 116,80	5111397 € 112,35
	X SPECIAL BELT BELT X K BELT BELT	6116117 € 34,27	6116118 € 35,00	6116215 € 31,00	-
	HTRoll ROLLERS FOR MULTIVAR 2000 / MHR	6611095.G0 € 13,64 gr.09,5	6611095.G0 € 13,64 gr.09,5	6611095.DO € 13,64 gr.08	6611095.G0 € 13,64 gr.09,5
	HTRoll ROLLERS FOR ORIGINAL VARIATOR	66 9456.F0 € 12,00 gr.08,7	66 9456.D0 € 12,00 gr.07,4	6611095.E0 € 13,64 gr.08,5	66 9456.D0 € 12,00 gr.07,4
	VENTILVAR 2000 FIXED HALF-PULLEY	-	-	-	-
	VARIABLE-SPEED DRIVE ADJUSTER SPRING FOR VARIATOR	PG.445	PG.445	2911266.Y0 *PG* € 10,71	PG.445
	TORSION CONTROLLER ANTIFRICTION FIFTH WHEEL	2513210 € 5,72	2513210 € 5,72	-	2513210 € 5,72
	TORQUE DRIVER MOBILE DRIVEN SPLIT PULLEY	6111656 € 123,88	6111656 € 123,88	6111658 € 108,00	6111656 € 123,88
	OVER RANGE TRANSMISSION KIT	-	-	-	-
	MAXI FLY CLUTCH NOT ADJUSTABLE CLUTCH	-	-	5212539 € 70,37 Ø 134	-
	MAXI DELTA CLUTCH ADJUSTABLE CLUTCH	5211821 € 120,42	5211821 € 120,42	5212492 € 104,00 Ø 134	5211821 € 120,42
	MAXI CLUTCH BELL CLUTCH BELL (SMOOTH RING)	-	-	-	-
	MAXI WING CLUTCH BELL CLUTCH BELL (FINNED RING)	7715898B € 52,00 Ø 134	7715898B € 52,00 Ø 134	-	-
	MAXI FLY SYSTEM CLUTCH BELL + NOT ADJUSTABLE CLUTCH	-	-	-	-
	MAXI DELTA SYSTEM CLUTCH BELL + ADJUSTABLE CLUTCH	5216918 € 136,00 Ø 134	5216918 € 136,00 Ø 134	-	-
	SPRINGS FOR MAXI FLY CLUTCH	-	-	29 9605 € 16,20	-
	SPRINGS FOR MAXI DELTA CLUTCH	2911326 € 17,00	2911326 € 17,00	29 9605 € 16,20	2911326 € 17,00
	SPRINGS FOR ORIGINAL CLUTCH	2911326 € 17,00	2911326 € 17,00	2911326 € 17,00	2911326 € 17,00

01 - TO COUPLE ONLY with MALOSSİ CYLINDERS: 3813273 € 475,00

62 - TO COUPLE ONLY with MALOSSİ CYLINDERS : 5911962 € 218,53

PG - SPECIFICATIONS on the PAGE indicated in the TITLE of the LINE

APRILIA

63

SCARABEO		SCARABEO		SCARABEO Light ie euro 3		SCARABEO		SCARABEO Light ie 2007->		SCARABEO Special ie euro 3		SCARABEO ie 2007->		SCARABEO Light ie 2007->	
(ROTAX)		(ROTAX)		(APRILIA CA03-CB01)		(PIAGGIO M285M)				(PIAGGIO M28RM)					
150 4T	LC	200 4T	LC	200 4T	LC	250 4T	LC	250 4T	LC	300 4T	LC	400 4T	LC	400 4T	LC
31 9990 € 292,98 Ø 67	-	-	-	3113928 € 335,00 Ø 74	3113928 € 335,00 Ø 74	3113958 € 335,00 Ø 75,5	-	-	-	-	-	-	-	-	-
-	-	-	-	-	-	-	-	-	-	-	-	-	-	-	-
5911229 € 100,54	-	-	-	-	-	-	-	-	-	-	-	5913846 € 227,63	5913846 € 227,63	-	-
-	-	-	-	3813273 € 475,00	3813273 € 475,00	3813273 € 475,00	-	-	-	-	-	-	-	-	-
-	-	-	-	3113927 € 745,00 Ø 74	3113927 € 745,00 Ø 74	3114700 € 745,00 Ø 75,5	-	-	-	-	-	-	-	-	-
-	-	-	-	-	-	-	-	-	-	-	-	-	-	-	-
-	-	-	-	2714047 € 118,53	2714047 € 118,53	2714047 € 118,53	-	-	-	-	-	-	-	-	-
-	-	-	-	2912834 € 21,54	2912834 € 21,54	2912834 € 21,54	2913068 € 22,74	2913068 € 22,74	-	-	-	-	-	-	-
-	-	-	-	-	-	-	-	-	-	-	-	-	-	-	-
-	-	-	-	-	-	-	-	-	-	-	-	-	-	-	-
-	-	-	-	5515724 € 255,84	5515724 € 255,84	5514780 € 255,84	-	-	-	-	-	-	-	-	-
-	-	-	-	-	5514749 € 84,00	5514746 € 90,00	-	-	-	-	-	-	-	-	-
5111257 € 116,80	5111875 € 110,96	5111885 € 112,35	5111885 € 112,35	5111885 € 112,35	5111885 € 112,35	5111885 € 112,35	5114260 € 173,04	5114260 € 173,04	-	-	-	-	-	-	-
6116215 € 31,00	6116215 € 31,00	-	6116069 € 60,00	6116069 € 60,00	6116069 € 60,00	6116069 € 60,00	6115125 € 88,54	6115125 € 88,54	-	-	-	-	-	-	-
6611095.F0 € 13,64 gr.09	6611095.H0 € 13,64 gr.10	6611095.R0 € 13,64 gr.14	6611095.T0 € 13,64 gr.15	6611095.T0 € 13,64 gr.15	6611095.T0 € 13,64 gr.15	6611095.T0 € 13,64 gr.15	6613554.B0 € 26,00 gr.15	6613554.B0 € 26,00 gr.15	-	-	-	-	-	-	-
6611095.G0 € 13,64 gr.09,5	-	-	6613697.I0 € 18,00 gr.11	6613697.I0 € 18,00 gr.11	-	-	6613554.C0 € 26,00 gr.16	6613554.C0 € 26,00 gr.16	-	-	-	-	-	-	-
-	-	-	-	-	-	-	-	-	-	-	-	-	-	-	-
2911266.Y0 *PG* € 10,71	2911266.Y0 *PG* € 10,71	PG.445	PG.445	PG.445	PG.445	PG.445	PG.445	PG.445	-	-	-	-	-	-	-
-	-	2513210 € 5,72	2513210 € 5,72	2513210 € 5,72	2513210 € 5,72	2513210 € 5,72	-	-	-	-	-	-	-	-	-
6111658 € 108,00	-	6111656 € 123,88	6112563 € 197,30	6112563 € 197,30	6112563 € 197,30	6112563 € 197,30	-	-	-	-	-	-	-	-	-
-	-	-	-	-	-	-	-	-	-	-	-	-	-	-	-
5212539 € 70,37 Ø 134	-	-	-	-	-	-	5212813 € 146,14	5212813 € 146,14	-	-	-	-	-	-	-
5212492 € 104,00 Ø 134	-	5211821 € 120,42	5211821 € 120,42	5211821 € 120,42	5211821 € 120,42	5211821 € 120,42	-	-	-	-	-	-	-	-	-
-	-	-	-	-	-	-	-	-	-	-	-	-	-	-	-
-	-	-	7715898B € 52,00 Ø 134	7715898B € 52,00 Ø 134	7715898B € 52,00 Ø 134	7715898B € 52,00 Ø 134	7715579B € 49,00 Ø 160	7715579B € 49,00 Ø 160	-	-	-	-	-	-	-
-	-	-	-	-	-	-	5216202 € 149,94 Ø 160	5216202 € 149,94 Ø 160	-	-	-	-	-	-	-
-	-	-	5216918 € 136,00 Ø 134	5216918 € 136,00 Ø 134	5216918 € 136,00 Ø 134	5216918 € 136,00 Ø 134	-	-	-	-	-	-	-	-	-
29 9605 € 16,20	-	-	-	-	-	-	-	-	-	-	-	-	-	2913137 € 20,99	-
29 9605 € 16,20	-	2911326 € 17,00	2911326 € 17,00	2911326 € 17,00	2911326 € 17,00	2911326 € 17,00	2913137 € 20,99	2913137 € 20,99	-	-	-	-	-	-	-
2911326 € 17,00	2911326 € 17,00	2911326 € 17,00	2911326 € 17,00	2911326 € 17,00	2911326 € 17,00	2911326 € 17,00	2912779 € 21,00	2912779 € 21,00	2912779 € 21,00	2912779 € 21,00	2912779 € 21,00	2912779 € 21,00	2912779 € 21,00	2912779 € 21,00	2912779 € 21,00

MAXI SCOOTER 125 → 800 4T



MALOSSI

Maxi Scooter

125 → 800 4T

with ENGINE 

APRILIA

MOJITO RY

SCARABEO

SCARABEO

SCARABEO Light
euro 3

(LEADER)

(PIAGGIO)

(ROTAX)

(APRILIA BA03)

() CHECK "TYPE" SPECIFICATION (HOMOLOGATION MARK).

125 4T



125 4T











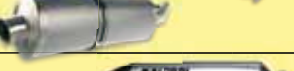





















LC

125 4T

LC

125 4T

LC

	CLUTCH DISK SET FOR ORIGINAL CLUTCH		-	-	-	-
	MAXI WILD LION   HOMOLOGATED EXHAUST SYSTEM	PG. 418	-	-	-	-
	RX   HOMOLOGATED EXHAUST SYSTEM	PG. 420	-	-	-	3215522 € 380,00
	RED CHILLI OIL OIL FILTER		0313382 € 7,00	0313382 € 7,00	0313384 € 4,57	-
	RED SPONGE FOR ORIGINAL AIR BOX		-	1416577 € 3,60	1416577 € 3,60	1413713 € 7,15
	DOUBLE RED SPONGE FOR ORIGINAL AIR BOX		1414532 € 6,70	-	-	1414485 € 7,50
	W BOX FOR ORIGINAL AIR BOX		-	-	-	-
	V FILTER VARIATOR AIR FILTER RIGHT SIDE		-	-	-	-
	POWER TRASMISSION		-	-	-	-
	GEARS HTQ PRIMARY		-	-	6711539 € 92,98 z 20/72	-
	GEARS HTQ SECONDARY		6711860 € 60,41 z 16/42	6712194 € 92,98 z 17/49	-	-
	SPORT SCREEN SCREEN		-	-	-	-
	MHR SCREEN SCREEN		-	-	-	-
	HOSE KIT FOR BRAKE		-	-	-	-
	BRAKE PADS FRONT ORGANIC BRAKE PADS		-	-	6215048 € 8,32 1998->	-
	BRAKE PADS MHR FRONT ORGANIC BRAKE PADS		-	-	62 9098 € 8,10 1998->	-
	BRAKE PADS MHR SYNT FRONT SINTERED BRAKE PADS		-	-	6215031 1998->03 € 17,16 6215037 2004->06 € 20,00	-
	BRAKE PADS REAR ORGANIC BRAKE PADS		-	-	-	-
	BRAKE PADS MHR REAR ORGANIC BRAKE PADS		-	-	-	-
	BRAKE PADS MHR SYNT REAR SINTERED BRAKE PADS		-	6215019 € 16,64	6215019 € 16,64 1998->	-
	BRAKE POWER REAR BRAKE SHOES		-	-	-	-
	DISC / WHOOP DISC / PAIR WHOOP FRONT BRAKE DISC		-	6212350 € 85,00	6212350 € 85,00 1999->	6212350 € 85,00
	DISC / WHOOP DISC REAR BRAKE DISC		-	-	-	-
	TWINS MAXI SUSPENSIONS REAR PAIR SHOCK ABSORBER		-	-	-	-
	RS3 - RS1 REAR SHOCK ABSORBER		-	-	-	-
	RS24 REAR SHOCK ABSORBER		-	-	-	-
	RS24 FRONT SHOCK ABSORBER		-	-	-	-
	RS24 FRONT + REAR		-	-	-	-
	F32S FORK STEMS Ø 32		-	-	-	-
	F37R FORK STEMS Ø 37		-	-	-	-

APRILIA

SCARABEO	SCARABEO	SCARABEO Light ie euro 3	SCARABEO	SCARABEO Light ie 2007->	SCARABEO Special ie euro 3	SCARABEO ie 2007->	SCARABEO Light ie 2007->
(ROTAX)	(ROTAX)	(APRILIA CA03-CB01)	(PIAGGIO M285M)		(PIAGGIO M28RM)		
150 4T LC	200 4T LC	200 4T LC	250 4T LC	250 4T LC	300 4T LC	400 4T LC	400 4T LC
-	-	-	-	-	-	-	-
-	-	-	-	-	-	-	-
-	-	3215522 € 380,00	-	-	3215526 € 356,50	-	-
-	0313384 € 4,57	-	0313382 € 7,00	0313382 € 7,00	0313382 € 7,00	0313383 € 7,42	0313383 € 7,42
1416577 € 3,60	1416577 € 3,60	1413713 € 7,15	1416577 € 3,60	1412129 € 5,10	1412129 € 5,10	1412129 € 5,10	1412129 € 5,10
-	-	1414485 € 7,50	-	1414496 € 7,35	1414496 € 7,35	1414496 € 7,35	1414496 € 7,35
-	-	-	-	-	-	-	-
-	-	-	-	-	-	-	-
-	-	-	-	-	-	-	-
6711539 € 92,98 z 20/72	-	-	-	-	-	-	-
-	-	-	-	-	-	-	-
-	-	-	-	-	-	-	-
-	6215048 € 8,32 2001->	-	6216938 € 14,00 2004->06	-	-	-	-
-	62 9098 € 8,10 2001->	-	-	-	-	-	-
6215031 € 17,16 1998->	6215031 € 17,16 2001->	-	6215037 € 20,00 2004->06	-	-	-	-
-	-	-	-	-	-	-	-
-	-	-	-	-	-	-	-
6215019 € 16,64 1998->	6215019 € 16,64 2001->	6215019 € 16,64	6215019 € 16,64	-	6215019 € 16,64	-	-
-	-	-	-	-	-	-	-
6212350 € 85,00 1999->	6212350 € 85,00 2001->	6212350 € 85,00	6212350 € 85,00	-	6212350 € 85,00	-	-
-	-	-	-	-	-	-	-
-	-	-	-	-	4613183 € 232,00	-	-
-	-	-	-	-	-	-	-
-	-	-	-	-	-	-	-
-	-	-	-	-	-	-	-
-	-	-	-	-	-	-	-
-	-	-	-	-	-	-	-
-	-	-	-	-	-	-	-
-	-	-	-	-	-	-	-

MAXI SCOOTER 125 → 800 4T



MALOSSI

Maxi Scooter

125 → 800 4T

with ENGINE 

APRILIA

SCARABEO

SCARABEO Light
ie
2007->

SPORTCITY

SPORTCITY ONE

(PIAGGIO M281M)

(LEADER M38AM)

500 4T

LC

500 4T

LC

125 4T

LC

125 4T



	CYLINDER 4 STROKE ALUMINIUM	-	-	3113955 € 335,00 Ø 75,5	3111393 € 302,60 Ø 70
	CYLINDER I-TECH ALUMINIUM EQUIPPED WITH CDI	-	-	-	-
	POWER CAM CAMSHAFT	5913846 € 227,63	5913846 € 227,63	*62*	-
	HEAD V4 HEAD FOR ORIGINAL CYLINDER / MALOSSI	-	-	*01*	-
	CYLINDER + V4 HEAD ALUMINIUM	-	-	-	-
	CYLINDER + V4 HEAD + POWER CAM ALUMINIUM Ø 75,5	-	-	3116208 € 895,00	-
	4 STROKE VALVE FOR ENGINE VALVES SET	-	-	2714047 € 118,53	-
	SPRINGS FOR ENGINE VALVES	2913068 € 22,74	2913068 € 22,74	2912834 € 21,54	-
	CRANKSHAFT RHQ	-	-	5312853 € 380,00	-
	IGNITION CONTROLLER DIGITRONIC FOR VEHICLES WITHOUT IMMOBILIZER	-	-	5512524 € 170,46	-
	IGNITION CONTROLLER DIGITRONIC FOR VEHICLES WITH IMMOBILIZER	-	-	5512341 € 170,46	-
	FORCE MASTER INJECTION CONTROLLER	-	-	-	-
	TC UNIT O2 controller LAMBDA EMULATOR	-	-	-	-
	MULTIVAR 2000 VARIATOR	5114260 (8 rollers) € 173,04	5114260 € 173,04	5111397 € 112,35	5111397 € 112,35
	MULTIVAR 2000 MHR	5111808 (6 rollers) € 172,79	-	-	-
	X SPECIAL BELT BELT	-	6115125 € 88,54	6116118 € 35,00	6116117 € 34,27
	X K BELT BELT	-	-	-	-
	HTRoll	6613554.B0 gr.15 (8) € 26,00	6613554.B0 € 26,00 gr.15	6611095.G0 € 13,64 gr.09,5	6611095.G0 € 13,64 gr.09,5
	ROLLERS FOR MULTIVAR 2000 / MHR	6613968.A0 gr.20 (6) € 17,81	-	66 9456.D0 € 12,00 gr.07,4	66 9456.F0 € 12,00 gr.08,7
	HTRoll	6613968.E0 € 17,81 gr.28 (6 rollers)	-	-	-
	ROLLERS FOR ORIGINAL VARIATOR	-	-	-	-
	VENTILVAR 2000 FIXED HALF-PULLEY	-	-	-	-
	VARIABLE-SPEED DRIVE ADJUSTER SPRING FOR VARIATOR	PG.445	PG.445	PG.445	PG.445
	TORSION CONTROLLER ANTIFRICTION FIFTH WHEEL	-	-	2513210 € 5,72	2513210 € 5,72
	TORQUE DRIVER MOBILE DRIVEN SPLIT PULLEY	-	-	6111656 € 123,88	6111656 € 123,88
	OVER RANGE TRANSMISSION KIT	-	-	-	-
	MAXI FLY CLUTCH NOT ADJUSTABLE CLUTCH	5212813 € 146,14	5212813 € 146,14	-	-
	MAXI DELTA CLUTCH ADJUSTABLE CLUTCH	-	-	5211821 € 120,42	5211821 € 120,42
	MAXI CLUTCH BELL CLUTCH BELL (SMOOTH RING)	-	-	-	-
	MAXI WING CLUTCH BELL CLUTCH BELL (FINNED RING)	7715579B € 49,00 Ø 160	7715579B € 49,00 Ø 160	7715898B € 52,00 Ø 134	7715898B € 52,00 Ø 134
	MAXI FLY SYSTEM CLUTCH BELL + NOT ADJUSTABLE CLUTCH	5216202 € 149,94 Ø 160	5216202 € 149,94 Ø 160	-	-
	MAXI DELTA SYSTEM CLUTCH BELL + ADJUSTABLE CLUTCH	-	-	5216918 € 136,00 Ø 134	5216918 € 136,00 Ø 134
	SPRINGS FOR MAXI FLY CLUTCH	2913137 € 20,99	2913137 € 20,99	-	-
	SPRINGS FOR MAXI DELTA CLUTCH	-	-	2911326 € 17,00	2911326 € 17,00
	SPRINGS FOR ORIGINAL CLUTCH	2912779 (5 masses) € 21,00 2911326 (3 masses) € 15,94	2912779 € 21,00	2911326 € 17,00	2911326 € 17,00

01 - TO COUPLE ONLY with MALOSSI CYLINDERS: 3813273 € 475,00

62 - TO COUPLE ONLY with MALOSSI CYLINDERS : 5911962 € 218,53

PG - SPECIFICATIONS on the PAGE indicated in the TITLE of the LINE

TEC1 ** ATTENTION ** PLEASE CHECK THE PROPER FITMENT : PAGE 416

APRILIA

BENELLI

SPORTCITY euro 3	SPORTCITY ie euro 3	SPORTCITY CUBE ie euro 3	SR MAX ie euro 3	SR MAX ie euro 3	SR MOTARD euro 3	SRV ie euro 3	ADIVA
(PIAGGIO M288M)	(PIAGGIO M288M)	(LEADER M28LM)				(PIAGGIO M554M)	(LEADER)
200 4T LC	250 4T LC	300 4T LC	125 4T LC	300 4T LC	125 4T LC	850 4T LC	125 4T LC
3113955 €335,00 Ø 75,5	3113928 €335,00 Ø 74	3113958 €335,00 Ø 75,5	-	3113958 €335,00 Ø 75,5	3111393 €302,60 Ø 70	-	3111393 €302,60 Ø 70
-	-	-	3116090 €520,00 Ø 75,5	-	-	-	-
5911962 €218,53	-	-	*TEC1*	-	-	-	-
01	3813273 €475,00	3813273 €475,00	*TEC1*	3813273 €475,00	-	-	-
-	3113927 €745,00 Ø 74	3114700 €745,00 Ø 75,5	-	3114700 €745,00 Ø 75,5	-	-	-
3116208 €895,00	-	-	*TEC1*	-	-	-	-
2714047 €118,53	2714047 €118,53	2714047 €118,53	-	2714047 €118,53	-	-	-
2912834 €21,54	2912834 €21,54	2912834 €21,54	2912834 €21,54	2912834 €21,54	-	-	-
5312896 €380,00	-	-	-	-	-	-	-
5512524 €170,46	-	-	-	-	-	-	-
5512341 €170,46	-	-	-	-	-	-	-
-	5515724 €255,84	5514780 €255,84	-	5514780 €255,84	-	-	-
-	5514749 €84,00	5514746 €90,00	5514746 €90,00	5514746 €90,00	-	-	-
5111885 €112,35	5111885 €112,35	5111885 €112,35	5111397 €112,35	5111885 €112,35	5111397 €112,35	5116230 €212,00	5111397 €112,35
6116697 €67,00	6116069 €60,00	6116069 €60,00	6116117 €34,27	6113027 €59,12	6116117 €34,27	6115126 €118,46	6116117 €34,27
6611095.R0 €13,64 gr.14	6611095.T0 €13,64 gr.15	6611095.T0 €13,64 gr.15	6611095.G0 €13,64 gr.09,5	6611095.T0 €13,64 gr.15	6611095.G0 €13,64 gr.09,5	6613655.C0+.H0 €27,00 gr.17 +19	6611095.G0 €13,64 gr.09,5
6613697.I0 €18,00 gr.11	6613697.I0 €18,00 gr.11	-	66 9456.D0 €12,00 gr.07,4	-	66 9456.F0 €12,00 gr.08,7	6613655.H0 €27,00 gr.19	66 9456.F0 €12,00 gr.08,7
-	-	-	-	-	-	-	-
PG.445	PG.445	PG.445	PG.445	PG.445	PG.445	2914121.W0*PG* €18,50	PG.445
2513210 €5,72	2513210 €5,72	2513210 €5,72	2513210 €5,72	2513210 €5,72	2513210 €5,72	-	2513210 €5,72
6112563 €197,30	6112563 €197,30	6112563 €197,30	6111656 €123,88	6112563 €197,30	6111656 €123,88	-	6111656 €123,88
-	-	-	-	-	-	-	-
-	-	-	-	-	-	-	-
5211821 €120,42	5211821 €120,42	5211821 €120,42	5211821 €120,42	5211821 €120,42	5211821 €120,42	-	5211821 €120,42
-	-	-	-	-	-	-	-
7715898B €52,00 Ø 134	7715898B €52,00 Ø 134	7715898B €52,00 Ø 134	7715898B €52,00 Ø 134	7715898B €52,00 Ø 134	7715898B €52,00 Ø 134	-	7715898B €52,00 Ø 134
-	-	-	-	-	-	-	-
5216918 €136,00 Ø 134	5216918 €136,00 Ø 134	5216918 €136,00 Ø 134	5216918 €136,00 Ø 134	5216918 €136,00 Ø 134	5216918 €136,00 Ø 134	-	5216918 €136,00 Ø 134
-	-	-	-	-	-	-	-
2911326 €17,00	2911326 €17,00	2911326 €17,00	2911326 €17,00	2911326 €17,00	2911326 €17,00	-	2911326 €17,00
2911326 €17,00	2911326 €17,00	2911326 €17,00	2911326 €17,00	2911326 €17,00	2911326 €17,00	2913725 €22,00	2911326 €17,00



MALOSSI

Maxi Scooter

125 → 800 4T

with ENGINE 

APRILIA

SCARABEO

SCARABEO Light
ie
2007->

SPORTCITY

SPORTCITY ONE

(PIAGGIO M281M)

(LEADER M38AM)

CHECK "TYPE" SPECIFICATION (HOMOLOGATION MARK).

500 4T

LC

500 4T











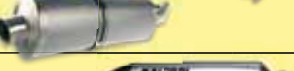





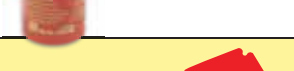





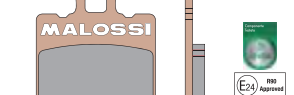

LC

125 4T

LC

125 4T



	CLUTCH DISK SET FOR ORIGINAL CLUTCH		-	-	-	-
	MAXI WILD LION   HOMOLOGATED EXHAUST SYSTEM		-	3214374 *69* € 476,34	-	-
	RX   HOMOLOGATED EXHAUST SYSTEM		-	-	3214791 € 380,00	-
	RED CHILLI OIL OIL FILTER		0313383 € 7,42	0313383 € 7,42	0313382 € 7,00	0313382 € 7,00
	RED SPONGE FOR ORIGINAL AIR BOX		-	1412129 € 5,10	1412129 € 5,10	-
	DOUBLE RED SPONGE FOR ORIGINAL AIR BOX		-	1414496 € 7,35	1414496 € 7,35	-
	W BOX FOR ORIGINAL AIR BOX		-	-	-	-
	V FILTER VARIATOR AIR FILTER RIGHT SIDE		-	-	-	-
	POWER TRASMISSION		-	-	-	-
	GEARS HTQ PRIMARY		-	-	-	-
	GEARS HTQ SECONDARY		-	-	6712194 € 92,98 z 17/49	6712067 € 69,96 z 15/41
	SPORT SCREEN SCREEN		-	-	-	-
	MHR SCREEN SCREEN		-	-	-	-
	HOSE KIT FOR BRAKE		-	-	-	-
	BRAKE PADS FRONT ORGANIC BRAKE PADS		6215048 € 8,32	-	6215048 € 8,32	6215062 € 8,32
	BRAKE PADS MHR FRONT ORGANIC BRAKE PADS		62 9098 € 8,10	-	62 9098 € 8,10	6215079 € 8,20
	BRAKE PADS MHR SYNT FRONT SINTERED BRAKE PADS		6215031 € 17,16	-	6215031 € 17,16	6215013 € 16,50
	BRAKE PADS REAR ORGANIC BRAKE PADS		-	-	-	-
	BRAKE PADS MHR REAR ORGANIC BRAKE PADS		-	-	-	-
	BRAKE PADS MHR SYNT REAR SINTERED BRAKE PADS		6215019 € 16,64	-	6215019 € 16,64	-
	BRAKE POWER REAR BRAKE SHOES		-	-	-	-
	DISC / WHOOP DISC / PAIR WHOOP FRONT BRAKE DISC		6212350 € 85,00	-	6212350 € 85,00	6212929 € 105,00
	DISC / WHOOP DISC REAR BRAKE DISC		-	-	-	-
	TWINS MAXI SUSPENSIONS REAR PAIR SHOCK ABSORBER		-	-	4613183 € 232,00	-
	RS3 - RS1 REAR SHOCK ABSORBER		-	-	-	-
	RS24 REAR SHOCK ABSORBER		-	-	-	-
	RS24 FRONT SHOCK ABSORBER		-	-	-	-
	RS24 FRONT + REAR		-	-	-	-
	F32S FORK STEMS Ø 32		-	-	-	-
	F37R FORK STEMS Ø 37		-	-	-	-

69 - ONLY homologated SILENCER

APRILIA

BENELLI

69

SPORTCITY euro 3	SPORTCITY ie euro 3	SPORTCITY CUBE ie euro 3	SR MAX ie euro 3	SR MAX ie euro 3	SR MOTARD euro 3	SRV ie euro 3	ADIVA
(PIAGGIO M288M)	(PIAGGIO M288M)	(LEADER M28LM)				(PIAGGIO M554M)	(LEADER)
200 4T LC	250 4T LC	300 4T LC	125 4T LC	300 4T LC	125 4T	850 4T LC	125 4T
-	-	-	-	-	-	-	-
-	-	-	-	-	3215950 € 395,00	3215536 € 712,98	-
3214791 € 380,00	-	3215964 € 380,00	-	3215237 € 380,00	-	-	-
0313382 € 7,00	0313382 € 7,00	0313382 € 7,00	0313382 € 7,00	0313382 € 7,00	0313382 € 7,00	-	0313382 € 7,00
1412129 € 5,10	1412129 € 5,10	1412129 € 5,10	1412129 € 5,10	1412129 € 5,10	-	-	-
1414496 € 7,35	1414496 € 7,35	1414496 € 7,35	1414496 € 7,35	1414496 € 7,35	1414532 € 6,70	-	-
-	-	-	-	-	-	-	-
-	-	-	-	-	-	-	-
-	-	-	-	-	-	-	-
-	-	-	-	-	-	-	-
6712194 € 92,98 z 17/49	-	-	6712194 € 92,98 z 17/49	-	6712067 € 69,96 z 15/41	-	6712067 € 69,96 z 15/41
-	-	-	4513099 € 61,50	4513099 € 61,50	-	-	-
-	-	-	-	-	-	-	-
6215048 € 8,32	6215048 € 8,32	6215048 € 8,32	6215062 € 8,32	6215062 € 8,32	6215062 € 8,32	6215052 € 8,00	-
62 9098 € 8,10	62 9098 € 8,10	62 9098 € 8,10	6215079 € 8,20	6215079 € 8,20	6215079 € 8,20	6211525 € 8,20	-
6215031 € 17,16	6215031 € 17,16	6215031 € 17,16	6215013 € 16,50	6215013 € 16,50	6215013 € 16,50	6215020 € 16,00	-
-	-	-	6215062 € 8,32	6215062 € 8,32	-	6215062 € 8,32	-
-	-	-	6215079 € 8,20	6215079 € 8,20	-	6215079 € 8,20	-
6215019 € 16,64	6215019 € 16,64	6215019 € 16,64	6215013 € 16,50	6215013 € 16,50	-	6215013 € 16,50	6215015 € 16,64 2000->
-	-	-	-	-	-	-	-
6212350 € 85,00	6212350 € 85,00	6212350 € 85,00	6212352 € 95,83	6212352 € 95,83	-	-	-
-	-	-	6212351 € 88,30	6212351 € 88,30	-	-	-
4613183 € 232,00	4613183 € 232,00	4613183 € 232,00	-	-	-	-	-
-	-	-	-	-	-	-	-
-	-	-	-	-	-	-	-
-	-	-	-	-	-	-	-
-	-	-	-	-	-	-	-
-	-	-	-	-	-	-	-
-	-	-	-	-	-	-	-
-	-	-	-	-	-	-	-

MAXI SCOOTER 125 → 800 4T



MALOSSI

Maxi Scooter

125 → 800 4T

with ENGINE **BENELLI**

ADIVA

ADIVA AD
euro 2CAFFÈNERO
euro 3

VELVET

(LEADER)

(QJ158M.J)

150 4T



250 4T

LC

150 4T

LC

125 4T

LC

	CYLINDER 4 STROKE ALUMINIUM	3111393 € 302,60 Ø 70	3113928 € 335,00 Ø 74	3111588 € 328,92 Ø 61	3111248 € 295,09 Ø 63
	CYLINDER I-TECH ALUMINIUM EQUIPPED WITH CDI	-	-	-	-
	POWER CAM CAMSHAFT	-	-	5912778 € 164,39	5911854 € 162,39
	HEAD V4 HEAD FOR ORIGINAL CYLINDER / MALOSSI	-	3813273 € 475,00	-	-
	CYLINDER + V4 HEAD ALUMINIUM	-	3113927 € 745,00 Ø 74	-	-
	CYLINDER + V4 HEAD + POWER CAM ALUMINIUM Ø 75,5	-	-	-	-
	4 STROKE VALVE FOR ENGINE VALVES SET	-	2714047 € 118,53	-	-
	SPRINGS FOR ENGINE VALVES	-	2912834 € 21,54	-	-
	CRANKSHAFT RHQ	-	-	-	-
	IGNITION CONTROLLER DIGITRONIC FOR VEHICLES WITHOUT IMMOBILIZER	-	-	-	-
	IGNITION CONTROLLER DIGITRONIC FOR VEHICLES WITH IMMOBILIZER	-	-	-	-
	FORCE MASTER INJECTION CONTROLLER	-	5515724 € 255,84	-	-
	TC UNIT O2 controller LAMBDA EMULATOR	-	-	-	-
	MULTIVAR 2000 VARIATOR MULTIVAR 2000 MHR	5111397 € 112,35	5111885 € 112,35	5111572 € 112,35 5114065 € 122,57	5113134 € 112,35
	X SPECIAL BELT BELT X K BELT BELT	6116117 € 34,27	-	6114127 € 24,42 6116422 € 48,57	6116101 € 42,50
	HTRoll ROLLERS FOR MULTIVAR 2000 / MHR	6611095.R0 € 13,64 gr.14	6611095.T0 € 13,64 gr.15	6611095.G0+.H0 € 13,64 gr.09,5 +10 MHR	6611095.D0+.I0 € 13,64 gr.08 (3) +10,5 (3)
	HTRoll ROLLERS FOR ORIGINAL VARIATOR	66 9456.H0 € 12,00 gr.10	-	6611534.B0 € 11,00 gr.11,5	6611156.C0 € 20,11 gr.09
	VENTILVAR 2000 FIXED HALF-PULLEY	-	-	6112672 € 36,72	6111703 € 36,72
	VARIABLE-SPEED DRIVE ADJUSTER SPRING FOR VARIATOR <small>PG. 445</small>	PG.445	PG.445	PG.445	2912647.Y0 *PG* € 10,00
	TORSION CONTROLLER ANTIFRICTION FIFTH WHEEL	2513210 € 5,72	2513210 € 5,72	-	-
	TORQUE DRIVER MOBILE DRIVEN SPLIT PULLEY	6111656 € 123,88	6112563 € 197,30	-	6111660 € 123,88
	OVER RANGE TRANSMISSION KIT	-	-	-	-
	MAXI FLY CLUTCH NOT ADJUSTABLE CLUTCH	-	-	5212522 € 70,37	-
	MAXI DELTA CLUTCH ADJUSTABLE CLUTCH	5211821 € 120,42	5211821 € 120,42	5212487 € 112,59	-
	MAXI CLUTCH BELL CLUTCH BELL (SMOOTH RING)	-	-	7714325 € 33,00 Ø 125	-
	MAXI WING CLUTCH BELL CLUTCH BELL (FINNED RING)	7715898B € 52,00 Ø 134	7715898B € 52,00 Ø 134	7713376 € 38,00 Ø 125	-
	MAXI FLY SYSTEM CLUTCH BELL + NOT ADJUSTABLE CLUTCH	-	-	5214724 € 100,47 Ø 125	-
	MAXI DELTA SYSTEM CLUTCH BELL + ADJUSTABLE CLUTCH	5216918 € 136,00 Ø 134	5216918 € 136,00 Ø 134	5216070 € 125,46 Ø 125	-
	SPRINGS FOR MAXI FLY CLUTCH	-	-	29 9605 € 16,20	-
	SPRINGS FOR MAXI DELTA CLUTCH	2911326 € 17,00	2911326 € 17,00	29 9605 € 16,20	-
	SPRINGS FOR ORIGINAL CLUTCH	2911326 € 17,00	2911326 € 17,00	2912536 € 15,56	2911325 € 17,24

PG - SPECIFICATIONS on the PAGE indicated in the TITLE of the LINE

BENELLI				BETA		BMW	
VELVET	VELVET	VELVET DUSK	ZENZERO ie euro 3	EIKON	EIKON	C Sport ie euro 4	C GT ie euro 4
			(T62N)				
150 4T LC	250 4T LC	400 4T LC	350 4T LC	125 4T LC	150 4T LC	600 4T LC	650 4T LC
3111248 € 295,09 Ø 63	31 9578 € 363,37 Ø 74	-	-	-	-	-	-
-	-	-	-	-	-	-	-
5911854 € 162,39	5911517 € 196,11	-	-	-	-	-	-
-	-	-	-	-	-	-	-
-	-	-	-	-	-	-	-
-	2711824 € 77,38	-	-	-	-	-	-
-	-	-	-	-	-	-	-
-	-	-	-	-	-	-	-
-	-	-	-	-	-	5515732 € 310,00	5515732 € 310,00
-	-	-	-	-	-	5515721 € 88,00	5515721 € 88,00
5113134 € 112,35	5111225 € 121,97	5114258 € 149,35	-	5111260 € 112,35	5111260 € 112,35	5115501 € 212,00	5115501 € 212,00
6116101 € 42,50	6116094 € 40,00	6113021 € 87,10	-	6116215 € 31,00	6116215 € 31,00	6115687 € 96,90	6115687 € 96,90
6611095.D0+.I0 € 13,64 gr.08 (3) +10,5 (3)	66 9919.G0 € 22,15 gr.11	6611367.E0 € 23,75 gr.16	-	6611095.G0 € 13,64 gr.09,5	6611095.G0 € 13,64 gr.09,5	6615657.F0+.H0 € 35,00 gr.22 +24	6615657.F0+.H0 € 35,00 gr.22 +24
6611156.E0 € 20,11 gr.10	66 9919.L0 € 22,15 gr.14	6611367.G0 € 23,75 gr.18	-	6611534.H0 € 11,00 gr.15,5	6611534.H0 € 11,00 gr.15,5	6615657.R0 € 35,00 gr.33	6615657.R0 € 35,00 gr.33
6111703 € 36,72	6111102B € 36,72	-	-	-	-	-	-
2912647.Y0 *PG* € 10,00	PG.445	2911429.Y0 *PG* € 11,50	-	2911384.Y0 *PG* € 10,71	2911384.Y0 *PG* € 10,71	2915497.W0 *PG* € 25,75	2915497.W0 *PG* € 25,75
-	-	-	-	-	-	-	-
6111660 € 123,88	6111763 € 159,12	-	-	-	-	-	-
-	-	-	-	-	-	-	-
-	-	-	-	-	-	-	-
5211888 € 120,42	5211468 € 129,23	-	-	-	-	-	-
7713368 € 59,00 Ø 135	7713368 € 59,00 Ø 135	7714329 € 115,00 Ø 150	-	-	-	-	-
-	-	-	-	-	-	-	-
-	-	-	-	-	-	-	-
-	-	-	-	-	-	-	-
2911326 € 17,00	2911326 € 17,00	-	-	-	-	-	-
2911326 € 17,00	2911325 € 17,24	-	2915089 € 16,20	2911326 € 17,00	2911326 € 17,00	-	-



MALOSSI

Maxi Scooter

125 → 800 4T

with ENGINE **BENELLI**

ADIVA

ADIVA AD
euro 2CAFFÈNERO
euro 3

VELVET

(LEADER)

(QJ158MJ)

() CHECK "TYPE" SPECIFICATION (HOMOLOGATION MARK).

150 4T



250 4T











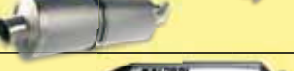





















LC

150 4T

LC

125 4T

LC

	CLUTCH DISK SET FOR ORIGINAL CLUTCH		-	-	-	-
	MAXI WILD LION   HOMOLOGATED EXHAUST SYSTEM		-	-	-	-
	RX   HOMOLOGATED EXHAUST SYSTEM		-	-	-	-
	RED CHILLI OIL OIL FILTER		0313382 € 7,00	0313382 € 7,00	-	-
	RED SPONGE FOR ORIGINAL AIR BOX		-	-	-	-
	DOUBLE RED SPONGE FOR ORIGINAL AIR BOX		-	-	-	-
	W BOX FOR ORIGINAL AIR BOX		-	-	-	-
	V FILTER VARIATOR AIR FILTER RIGHT SIDE		-	-	-	-
	POWER TRASMISSION		-	-	-	-
	GEARS HTQ PRIMARY		-	-	-	-
	GEARS HTQ SECONDARY		6712067 € 69,96 z 15/41	-	-	6711238 € 68,58 z 14/43 <-2000
	SPORT SCREEN SCREEN		-	-	-	-
	MHR SCREEN SCREEN		-	-	-	-
	HOSE KIT FOR BRAKE		-	-	-	-
	BRAKE PADS FRONT ORGANIC BRAKE PADS		-	-	-	6215042 € 5,72 1999->
	BRAKE PADS MHR FRONT ORGANIC BRAKE PADS		-	-	-	6215080 € 6,00 1999->
	BRAKE PADS MHR SYNT FRONT SINTERED BRAKE PADS		-	-	-	6215007 € 11,96 1999->
	BRAKE PADS REAR ORGANIC BRAKE PADS		-	-	-	6215042 € 5,72 1999->
	BRAKE PADS MHR REAR ORGANIC BRAKE PADS		-	-	-	6215080 € 6,00 1999->
	BRAKE PADS MHR SYNT REAR SINTERED BRAKE PADS		6215015 € 16,64 2000->	-	-	6215007 € 11,96 1999->
	BRAKE POWER REAR BRAKE SHOES		-	-	-	-
	DISC / WHOOP DISC / PAIR WHOOP FRONT BRAKE DISC		-	-	6212342 € 87,50	-
	DISC / WHOOP DISC REAR BRAKE DISC		-	-	6212342 € 87,50	-
	TWINS MAXI SUSPENSIONS REAR PAIR SHOCK ABSORBER		-	-	-	-
	RS3 - RS1 REAR SHOCK ABSORBER		-	-	-	-
	RS24 REAR SHOCK ABSORBER		-	-	-	-
	RS24 FRONT SHOCK ABSORBER		-	-	-	-
	RS24 FRONT + REAR		-	-	-	-
	F32S FORK STEMS Ø 32		-	-	-	-
	F37R FORK STEMS Ø 37		-	-	-	-

69 - ONLY homologated SILENCER

NB - the vehicle needs 2 front brake DISCS

69 - SPECIFICATIONS on the PAGE indicated in the TITLE of the LINE

BENELLI				BETA				BMW							
VELVET		VELVET		VELVET DUSK		ZENZERO ie euro 3		EIKON		EIKON		C Sport ie euro 4		C GT ie euro 4	
						(T62N)									
150 4T	LC	250 4T	LC	400 4T	LC	350 4T	LC	125 4T	LC	150 4T	LC	600 4T	LC	650 4T	LC
-		-		-		-		-		-		-		-	
-		-		-		-		-		-		3215629B *69*		3215927 *69*	
-		-		-		-		-		-		€ 454,41		€ 460,00	
-		-		-		-		-		-		-		-	
-		1411417		-		-		-		-		-		-	
-		€ 9,06		-		-		-		-		-		-	
-		1414502		-		-		-		-		-		-	
-		€ 7,35		-		-		-		-		-		-	
-		-		-		-		-		-		1415541		1415541	
-		-		-		-		-		-		€ 39,00		€ 39,00	
-		-		-		-		-		-		-		-	
-		-		-		-		-		-		-		-	
-		67 9974		-		-		-		-		-		-	
-		€ 90,27 z 17/37		-		-		-		-		-		-	
-		-		-		-		-		-		4515571B LIGHT-SMOKE	€ 65,00	-	
-		-		-		-		-		-		4515607B CLEAR	€ 59,45	-	
6215042		-		-		-		-		-		6216902		6216902	
€ 5,72 1999->		-		-		-		-		-		€ 9,87		€ 9,87	
6215080		-		-		-		-		-		-		-	
€ 6,00 1999->		-		-		-		-		-		-		-	
6215007		6215011		-		-		6215009		6215009		6215572		6215572	
€ 11,96 1999->		€ 16,00 1999->		-		-		€ 14,50 1999->		€ 14,50 1999->		€ 17,16		€ 17,16	
6215042		-		-		6215059		-		-		6216902		6216902	
€ 5,72 1999->		-		-		€ 8,84		-		-		€ 9,87		€ 9,87	
6215080		-		-		6212164		-		-		-		-	
€ 6,00 1999->		-		-		€ 8,50		-		-		-		-	
6215007		6215019		-		-		6215019		6215019		6215572		6215572	
€ 11,96 1999->		€ 16,64 1999->		-		-		€ 16,64 1999->		€ 16,64 1999->		€ 17,16		€ 17,16	
-		-		-		-		-		-		-		-	
-		-		-		-		-		-		6215471 *NB*		6215471 *NB*	
-		-		-		-		-		-		€ 103,00		€ 103,00	
-		-		-		-		-		-		6215471		6215471	
-		-		-		-		-		-		€ 103,00		€ 103,00	
-		-		-		-		-		-		-		-	
-		-		-		-		-		-		-		-	
-		-		-		-		-		-		-		-	
-		-		-		-		-		-		-		-	
-		-		-		-		-		-		-		-	
-		-		-		-		-		-		-		-	
-		-		-		-		-		-		-		-	
-		-		-		-		-		-		-		-	



MALOSSİ

Maxi Scooter

125 → 800 4T

with ENGINE 

CF MOTO

DERBI

URBAN R

BOULEVARD

BOULEVARD

BOULEVARD

(1P 58 MJ)

(LEADER)

(LEADER)

(PIAGGIO M387M)

150 4T

LC

125 4T



150 4T



200 4T





Products to be used exclusively for racing in places specially designed for such activity according to the regulations of the competent sporting authorities. We accept no liability resulting from improper use.

	CYLINDER 4 STROKE ALUMINIUM	-	3111393 € 302,60 Ø 70	3111393 € 302,60 Ø 70	-
	CYLINDER I-TECH ALUMINIUM EQUIPPED WITH CDI	-	-	-	-
	POWER CAM CAMSHAFT	-	-	-	-
	HEAD V4 HEAD FOR ORIGINAL CYLINDER / MALOSSİ	-	-	-	-
	CYLINDER + V4 HEAD ALUMINIUM	-	-	-	-
	CYLINDER + V4 HEAD + POWER CAM ALUMINIUM Ø 75,5	-	-	-	-
	4 STROKE VALVE FOR ENGINE VALVES SET	-	-	-	-
	SPRINGS FOR ENGINE VALVES	-	-	-	-
	CRANKSHAFT RHQ	-	-	-	-
	IGNITION CONTROLLER DIGITRONIC FOR VEHICLES WITHOUT IMMOBILIZER	-	-	-	-
	IGNITION CONTROLLER DIGITRONIC FOR VEHICLES WITH IMMOBILIZER	-	-	-	-
	FORCE MASTER INJECTION CONTROLLER	-	-	-	-
	TC UNIT O2 controller LAMBDA EMULATOR	-	-	-	-
	MULTIVAR 2000 VARIATOR MULTIVAR 2000 MHR	5114272 € 112,35	5111397 € 112,35	5111397 € 112,35	5111885 € 112,35
	X SPECIAL BELT BELT X K BELT BELT	6114127 € 24,42 6116422 € 48,57	6116117 € 34,27	6116117 € 34,27	-
	HTRoll ROLLERS FOR MULTIVAR 2000 / MHR	6611095.M0 € 13,64 gr.11,5	6611095.G0 € 13,64 gr.09,5	6611095.F0 € 13,64 gr.14	6611095.R0 € 13,64 gr.14
	HTRoll ROLLERS FOR ORIGINAL VARIATOR	-	66 9456.F0 € 12,00 gr.08,7	66 9456.H0 € 12,00 gr.10	6613697.I0 € 18,00 gr.11
	VENTILVAR 2000 FIXED HALF-PULLEY	-	-	-	-
	VARIABLE-SPEED DRIVE ADJUSTER SPRING FOR VARIATOR	PG.445	PG.445	PG.445	PG.445
	TORSION CONTROLLER ANTIFRICTION FIFTH WHEEL	-	2513210 € 5,72	2513210 € 5,72	2513210 € 5,72
	TORQUE DRIVER MOBILE DRIVEN SPLIT PULLEY	-	6111656 € 123,88	6111656 € 123,88	6111656 € 123,88
	OVER RANGE TRANSMISSION KIT	-	-	-	-
	MAXI FLY CLUTCH NOT ADJUSTABLE CLUTCH	5212522 € 70,37	-	-	-
	MAXI DELTA CLUTCH ADJUSTABLE CLUTCH	5212487 € 112,59	5211821 € 120,42	5211821 € 120,42	5211821 € 120,42
	MAXI CLUTCH BELL CLUTCH BELL (SMOOTH RING)	7714325 € 33,00 Ø 125	-	-	-
	MAXI WING CLUTCH BELL CLUTCH BELL (FINNED RING)	-	7715898B € 52,00 Ø 134	7715898B € 52,00 Ø 134	7715898B € 52,00 Ø 134
	MAXI FLY SYSTEM CLUTCH BELL + NOT ADJUSTABLE CLUTCH	5214724 € 100,47 Ø 125	-	-	-
	MAXI DELTA SYSTEM CLUTCH BELL + ADJUSTABLE CLUTCH	-	5216918 € 136,00 Ø 134	5216918 € 136,00 Ø 134	5216918 € 136,00 Ø 134
	SPRINGS FOR MAXI FLY CLUTCH	29 9605 € 16,20	-	-	-
	SPRINGS FOR MAXI DELTA CLUTCH	29 9605 € 16,20	2911326 € 17,00	2911326 € 17,00	2911326 € 17,00
	SPRINGS FOR ORIGINAL CLUTCH	-	2911326 € 17,00	2911326 € 17,00	2911326 € 17,00

01 - TO COUPLE ONLY with MALOSSİ CYLINDERS: 3813273 € 475,00

62 - TO COUPLE ONLY with MALOSSİ CYLINDERS : 5911962 € 218,53

DERBI					GARELLI		GILERA
GP1 euro 2-3	GP1 euro 2-3	RAMBLA euro 3	RAMBLA ie euro 3	RAMBLA i ie euro 3	XO' ie euro 3	XO' ie euro 3	DNA
		(PIAGGIO M287M)		(PIAGGIO)	(1P52 QMI-2)	(1P58 QMJ)	
125 4T LC	250 4T LC	125 4T LC	250 4T LC	300 4T LC	125 4T 	150 4T 	125 4T LC
3113955 € 335,00 Ø 75,5	3113928 € 335,00 Ø 74	3113955 € 335,00 Ø 75,5	3113928 € 335,00 Ø 74	3113958 € 335,00 Ø 75,5	-	-	3113955 € 335,00 Ø 75,5
-	-	-	-	-	-	-	-
62	-	*62*	-	-	-	-	*62*
01	3813273 € 475,00	*01*	3813273 € 475,00	3813273 € 475,00	-	-	*01*
-	3113927 € 745,00 Ø 74	-	3113927 € 745,00 Ø 74	3114700 € 745,00 Ø 75,5	-	-	-
3116208 € 895,00	-	3116208 € 895,00	-	-	-	-	3116208 € 895,00
2714047 € 118,53	2714047 € 118,53	2714047 € 118,53	2714047 € 118,53	2714047 € 118,53	-	-	2714047 € 118,53
2912834 € 21,54	2912834 € 21,54	2912834 € 21,54	2912834 € 21,54	2912834 € 21,54	-	-	2912834 € 21,54
5312853 € 380,00	-	5312853 € 380,00	-	-	-	-	5312853 € 380,00
-	-	5512524 € 170,46	-	-	-	-	5512524 € 170,46
5512341 € 170,46	-	5512341 € 170,46	-	-	-	-	5512341 € 170,46
-	5515724 € 255,84	-	-	5514780 € 255,84	-	-	-
-	-	-	5514749 € 84,00	5514746 € 90,00	-	-	-
5111397 € 112,35	5111885 € 112,35	5111397 € 112,35	5111885 € 112,35	5111885 € 112,35	5114272 € 112,35	5114272 € 112,35	5111397 € 112,35
6116117 € 34,27	6113027 € 59,12	6116118 € 35,00	6116069 € 60,00	6116069 € 60,00	6114127 € 24,42 6116422 € 48,57	6114127 € 24,42 6116422 € 48,57	6116117 € 34,27
6611095.G0 € 13,64 gr.09,5	6611095.T0 € 13,64 gr.15	6611095.G0 € 13,64 gr.09,5	6611095.T0 € 13,64 gr.15	6611095.T0 € 13,64 gr.15	-	6611095.M0 € 13,64 gr.11,5	6611095.G0 € 13,64 gr.09,5
66 9456.D0 € 12,00 gr.07,4	-	66 9456.D0 € 12,00 gr.07,4	6613697.I0 € 18,00 gr.11	-	6611095.M0 € 13,64 gr.11,5	-	66 9456.H0 € 12,00 gr.10
-	-	-	-	-	-	-	-
PG.445	PG.445	PG.445	PG.445	PG.445	PG.445	PG.445	PG.445
2513210 € 5,72	2513210 € 5,72	2513210 € 5,72	2513210 € 5,72	2513210 € 5,72	-	-	2513210 € 5,72
6111656 € 123,88	6112563 € 197,30	6111656 € 123,88	6112563 € 197,30	6112563 € 197,30	-	-	6111656 € 123,88
-	-	-	-	-	-	-	-
-	-	-	-	-	5212522 € 70,37	5212522 € 70,37	-
5211821 € 120,42	5211821 € 120,42	5211821 € 120,42	5211821 € 120,42	5211821 € 120,42	5212487 € 112,59	5212487 € 112,59	5211821 € 120,42
-	-	-	-	-	7714325 € 33,00 Ø 125	7714325 € 33,00 Ø 125	-
7715898B € 52,00 Ø 134	7715898B € 52,00 Ø 134	7715898B € 52,00 Ø 134	7715898B € 52,00 Ø 134	7715898B € 52,00 Ø 134	7713376 € 38,00 Ø 125	7713376 € 38,00 Ø 125	7715898B € 52,00 Ø 134
-	-	-	-	-	5214724 € 100,47 Ø 125	5214724 € 100,47 Ø 125	-
5216918 € 136,00 Ø 134	5216918 € 136,00 Ø 134	5216918 € 136,00 Ø 134	5216918 € 136,00 Ø 134	5216918 € 136,00 Ø 134	5216070 € 125,46 Ø 125	5216070 € 125,46 Ø 125	5216918 € 136,00 Ø 134
-	-	-	-	-	29 9605 € 16,20	29 9605 € 16,20	-
2911326 € 17,00	2911326 € 17,00	2911326 € 17,00	2911326 € 17,00	2911326 € 17,00	29 9605 € 16,20	29 9605 € 16,20	2911326 € 17,00
2911326 € 17,00	2911326 € 17,00	2911326 € 17,00	2911326 € 17,00	2911326 € 17,00	2913725 € 22,00	2913725 € 22,00	2911326 € 17,00



MALOSSI

Maxi Scooter

125 → 800 4T

with ENGINE 

CF MOTO

DERBI

URBAN R

BOULEVARD

BOULEVARD

BOULEVARD

(1P 58 MJ)

(LEADER)

(LEADER)

(PIAGGIO M387M)

 CHECK "TYPE" SPECIFICATION (HOMOLOGATION MARK).

150 4T

LC

125 4T











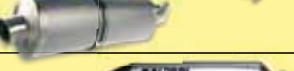



























150 4T



200 4T



	CLUTCH DISK SET FOR ORIGINAL CLUTCH		-	-	-	-
	MAXI WILD LION  HOMOLOGATED EXHAUST SYSTEM	 	PG. 418	-	-	-
	RX  HOMOLOGATED EXHAUST SYSTEM	 	PG. 420	-	-	-
	RED CHILLI OIL OIL FILTER		-	0313382 € 7,00	0313382 € 7,00	0313382 € 7,00
	RED SPONGE FOR ORIGINAL AIR BOX		-	-	-	-
	DOUBLE RED SPONGE FOR ORIGINAL AIR BOX		-	1414532 € 6,70	1414532 € 6,70	-
	W BOX FOR ORIGINAL AIR BOX		-	-	-	-
	V FILTER VARIATOR AIR FILTER RIGHT SIDE		-	-	-	-
	POWER TRASMISSION		-	-	-	-
	GEARS HTQ PRIMARY		-	-	-	-
	GEARS HTQ SECONDARY		-	6712067 € 69,96 z 15/41	6712067 € 69,96 z 15/41	-
	SPORT SCREEN SCREEN		-	-	-	-
	MHR SCREEN SCREEN		-	-	-	-
	HOSE KIT FOR BRAKE		-	-	-	-
	BRAKE PADS FRONT ORGANIC BRAKE PADS		-	-	-	-
	BRAKE PADS MHR FRONT ORGANIC BRAKE PADS		-	-	-	-
	BRAKE PADS MHR SYNT FRONT SINTERED BRAKE PADS		-	-	-	-
	BRAKE PADS REAR ORGANIC BRAKE PADS		6215055 € 8,84	-	-	-
	BRAKE PADS MHR REAR ORGANIC BRAKE PADS		6215078 € 8,84	-	-	-
	BRAKE PADS MHR SYNT REAR SINTERED BRAKE PADS		-	-	-	-
	BRAKE POWER REAR BRAKE SHOES		-	-	-	-
	DISC / WHOOP DISC / PAIR WHOOP FRONT BRAKE DISC		-	-	-	6212929 € 105,00
	DISC / WHOOP DISC REAR BRAKE DISC		-	-	-	-
	TWINS MAXI SUSPENSIONS REAR PAIR SHOCK ABSORBER		-	-	-	-
	RS3 - RS1 REAR SHOCK ABSORBER		-	-	-	-
	RS24 REAR SHOCK ABSORBER		-	-	-	-
	RS24 FRONT SHOCK ABSORBER		-	-	-	-
	RS24 FRONT + REAR		-	-	-	-
	F32S FORK STEMS Ø 32		-	-	-	-
	F37R FORK STEMS Ø 37		-	-	-	-

DERBI					GARELLI		GILERA
GP1 euro 2-3	GP1 euro 2-3	RAMBLA euro 3	RAMBLA ie euro 3	RAMBLA i ie euro 3	XO' ie euro 3	XO' ie euro 3	DNA
		(PIAGGIO M287M)		(PIAGGIO)	(1P52 QMI-2)	(1P58 QMJ)	
125 4T LC	250 4T LC	125 4T LC	250 4T LC	300 4T LC	125 4T 	150 4T 	125 4T LC
-	-	-	-	-	-	-	-
-	-	-	-	-	-	-	-
-	-	-	-	-	-	-	-
0313382 € 7,00	0313382 € 7,00	0313382 € 7,00	0313382 € 7,00	0313382 € 7,00	-	-	0313382 € 7,00
1412129 € 5,10	1412129 € 5,10	1412129 € 5,10	1412129 € 5,10	1412129 € 5,10	-	-	1411839 € 5,12
1414496 € 7,35	1414496 € 7,35	1414496 € 7,35	1414496 € 7,35	1414496 € 7,35	-	-	-
-	-	-	-	-	-	-	-
-	-	-	-	-	-	-	-
-	-	-	-	-	-	-	-
-	-	6712194 € 92,98 z 17/49	-	-	-	-	6712067 € 69,96 z 15/41
-	-	-	-	-	-	-	-
-	-	6215048 € 8,32	6215048 € 8,32	-	-	-	-
-	-	62 9098 € 8,10	62 9098 € 8,10	-	-	-	-
-	-	6215031 € 17,16	6215031 € 17,16	-	-	-	6215011 € 16,00 2000->
-	-	-	-	-	-	-	-
-	-	-	-	-	-	-	-
-	-	6215019 € 16,64	6215019 € 16,64	-	-	-	6215015 € 16,64 2000->
-	-	-	-	-	-	-	-
-	-	6212350 € 85,00	6212350 € 85,00	-	-	-	6211702 2000-> € 83,67 6212351 2000-> € 88,30
-	-	-	-	-	-	-	-
-	-	4613183 € 232,00	4613183 € 232,00	4613183 € 232,00	-	-	-
-	-	-	-	-	-	-	-
-	-	-	-	-	-	-	-
-	-	-	-	-	-	-	-
-	-	-	-	-	-	-	-
-	-	-	-	-	-	-	-
-	-	-	-	-	-	-	-
-	-	-	-	-	-	-	-



MALOSSİ

Maxi Scooter

125 → 800 4T

with ENGINE **GILERA**

DNA

FUOCO
ie euro 3

GP

NEXUS
euro 3

(PIAGGIO M554M)

180 4T

LC

500 4T

LC

800 4T

LC

125 4T

LC

	CYLINDER 4 STROKE ALUMINIUM	3113955 € 335,00 Ø 75,5	-	-	3113955 € 335,00 Ø 75,5
	CYLINDER I-TECH ALUMINIUM EQUIPPED WITH CDI	-	-	-	-
	POWER CAM CAMSHAFT	5911962 € 218,53	5913846 € 227,63	-	*62*
	HEAD V4 HEAD FOR ORIGINAL CYLINDER / MALOSSİ	*01*	-	-	*01*
	CYLINDER + V4 HEAD ALUMINIUM	-	-	-	-
	CYLINDER + V4 HEAD + POWER CAM ALUMINIUM Ø 75,5	3116208 € 895,00	-	-	3116208 € 895,00
	4 STROKE VALVE FOR ENGINE VALVES SET	2714047 € 118,53	-	-	2714047 € 118,53
	SPRINGS FOR ENGINE VALVES	2912834 € 21,54	2913068 € 22,74	-	2912834 € 21,54
	CRANKSHAFT RHQ	5312896 € 380,00	-	-	5312853 € 380,00
	IGNITION CONTROLLER DIGITRONIC FOR VEHICLES WITHOUT IMMOBILIZER	5512524 € 170,46	-	-	5512524 € 170,46
	IGNITION CONTROLLER DIGITRONIC FOR VEHICLES WITH IMMOBILIZER	5512341 € 170,46	-	-	5512341 € 170,46
	FORCE MASTER INJECTION CONTROLLER	-	-	-	-
	TC UNIT O2 controller LAMBDA EMULATOR	-	-	-	-
	MULTIVAR 2000 VARIATOR MULTIVAR 2000 MHR	5111594 € 112,35	5114260 € 173,04	5116230 € 212,00	5111397 € 112,35
	X SPECIAL BELT BELT X K BELT BELT	-	6115125 € 88,54	6115126 € 118,46	6116117 € 34,27
	HTRoll ROLLERS FOR MULTIVAR 2000 / MHR	6611095.R0 € 13,64 gr.14	6613554.B0 € 26,00 gr.15	6613655.C0+.H0 € 27,00 gr.17 +19	6611095.G0 € 13,64 gr.09,5
	HTRoll ROLLERS FOR ORIGINAL VARIATOR	-	-	6613655.H0 € 27,00 gr.19	66 9456.D0 € 12,00 gr.07,4
	VENTILVAR 2000 FIXED HALF-PULLEY	-	-	-	-
	VARIABLE-SPEED DRIVE ADJUSTER SPRING FOR VARIATOR	PG.445	PG.445	PG.445	2914121.W0*PG* € 18,50
	TORSION CONTROLLER ANTIFRICTION FIFTH WHEEL	2513210 € 5,72	-	-	2513210 € 5,72
	TORQUE DRIVER MOBILE DRIVEN SPLIT PULLEY	6111656 € 123,88	-	-	6111656 € 123,88
	OVER RANGE TRANSMISSION KIT	-	-	-	-
	MAXI FLY CLUTCH NOT ADJUSTABLE CLUTCH	-	5212813 € 146,14	-	-
	MAXI DELTA CLUTCH ADJUSTABLE CLUTCH	5211821 € 120,42	-	-	5211821 € 120,42
	MAXI CLUTCH BELL CLUTCH BELL (SMOOTH RING)	-	-	-	-
	MAXI WING CLUTCH BELL CLUTCH BELL (FINNED RING)	7715898B € 52,00 Ø 134	7715579B € 49,00 Ø 160	-	7715898B € 52,00 Ø 134
	MAXI FLY SYSTEM CLUTCH BELL + NOT ADJUSTABLE CLUTCH	-	5216202 € 149,94 Ø 160	-	-
	MAXI DELTA SYSTEM CLUTCH BELL + ADJUSTABLE CLUTCH	5216918 € 136,00 Ø 134	-	-	5216918 € 136,00 Ø 134
	SPRINGS FOR MAXI FLY CLUTCH	-	2913137 € 20,99	-	-
	SPRINGS FOR MAXI DELTA CLUTCH	2911326 € 17,00	-	-	2911326 € 17,00
	SPRINGS FOR ORIGINAL CLUTCH	2911326 € 17,00	2912779 € 21,00	2913725 € 22,00	2911326 € 17,00

01 - TO COUPLE ONLY with MALOSSİ CYLINDERS: 3813273 € 475,00

16 - ATTENTION, ONLY for EURO 3 vehicles: 6115125 € 88,54

62 - TO COUPLE ONLY with MALOSSİ CYLINDERS : 5911962 € 218,53

PG - SPECIFICATIONS on the PAGE indicated in the TITLE of the LINE

GILERA

NEXUS ie euro 3		NEXUS ie euro 3		NEXUS ie euro 3		NEXUS ie euro 2-3		RUNNER ST euro 3		RUNNER ST euro 3		RUNNER VX <-2005		RUNNER VX 2006->	
125 4T	LC	250 4T	LC	300 4T	LC	500 4T	LC	125 4T	LC	200 4T	LC	125 4T	LC	125 4T	LC
-		3113928 € 335,00 Ø 74		3113958 € 335,00 Ø 75,5		-		3113955 € 335,00 Ø 75,5		3113955 € 335,00 Ø 75,5		3113955 € 335,00 Ø 75,5		3113955 € 335,00 Ø 75,5	
3116090 € 520,00 Ø 75,5		-		-		-		-		-		-		-	
TEC1		-		-		5913846 € 227,63		*62*		5911962 € 218,53		*62*		*62*	
TEC1		3813273 € 475,00		3813273 € 475,00		-		*01*		*01*		*01*		*01*	
-		3113927 € 745,00 Ø 74		3114700 € 745,00 Ø 75,5		-		-		-		-		-	
TEC1		-		-		-		3116208 € 895,00		3116208 € 895,00		3116208 € 895,00		3116208 € 895,00	
-		2714047 € 118,53		2714047 € 118,53		-		2714047 € 118,53		2714047 € 118,53		2714047 € 118,53		2714047 € 118,53	
2912834 € 21,54		2912834 € 21,54		2912834 € 21,54		2913068 € 22,74		2912834 € 21,54		2912834 € 21,54		2912834 € 21,54		2912834 € 21,54	
-		-		-		-		5312853 € 380,00		5312896 € 380,00		5312853 € 380,00		5312853 € 380,00	
-		-		-		-		5512524 € 170,46		-		5512524 € 170,46		5512524 € 170,46	
-		-		-		-		5512341 € 170,46		5512341 € 170,46		5512341 € 170,46		5512341 € 170,46	
-		5515724 € 255,84		5514780 € 255,84		-		-		-		-		-	
5514746 € 90,00		5514749 € 84,00		5514746 € 90,00		-		-		-		-		-	
5111397 € 112,35		5111885 € 112,35		5111885 € 112,35		5114260 (8 rollers) € 173,04 5111808 (6 rollers) € 172,79		5111397 € 112,35		5111885 € 112,35		5111397 € 112,35		5111397 € 112,35	
6116117 € 34,27		6113027 € 59,12		6113027 € 59,12		*16*		6116117 € 34,27		6115666 € 46,92		6116117 € 34,27		6116117 € 34,27	
6611095.G0 € 13,64 gr.09,5		6611095.T0 € 13,64 gr.15		6611095.T0 € 13,64 gr.15		6613554.B0 gr.15 (8) € 26,00 6613968.A0 gr.20 (6) € 17,81		6611095.G0 € 13,64 gr.09,5		6611095.R0 € 13,64 gr.14		6611095.G0 € 13,64 gr.09,5		6611095.G0 € 13,64 gr.09,5	
66 9456.D0 € 12,00 gr.07,4		6613697.I0 € 18,00 gr.11		-		6612124.G0 € 15,59 gr.30 (6 rollers)		66 9456.D0 € 12,00 gr.07,4		6613697.I0 € 18,00 gr.11		66 9456.D0 € 12,00 gr.07,4		66 9456.D0 € 12,00 gr.07,4	
-		-		-		-		-		-		-		-	
PG.445		PG.445		PG.445		PG.445		PG.445		PG.445		PG.445		PG.445	
2513210 € 5,72		2513210 € 5,72		2513210 € 5,72		-		2513210 € 5,72		2513210 € 5,72		2513210 € 5,72		2513210 € 5,72	
6111656 € 123,88		6112563 € 197,30		6112563 € 197,30		-		6111656 € 123,88		6112563 € 197,30		6111656 € 123,88		6111656 € 123,88	
-		-		-		-		-		-		-		-	
-		-		-		5212813 € 146,14		-		-		-		-	
5211821 € 120,42		5211821 € 120,42		5211821 € 120,42		-		5211821 € 120,42		5211821 € 120,42		5211821 € 120,42		5211821 € 120,42	
-		-		-		7715579B € 49,00 Ø 160		-		-		-		-	
7715898B € 52,00 Ø 134		7715898B € 52,00 Ø 134		7715898B € 52,00 Ø 134		-		7715898B € 52,00 Ø 134		7715898B € 52,00 Ø 134		7715898B € 52,00 Ø 134		7715898B € 52,00 Ø 134	
-		-		-		5216202 € 149,94 Ø 160		-		-		-		-	
5216918 € 136,00 Ø 134		5216918 € 136,00 Ø 134		5216918 € 136,00 Ø 134		-		5216918 € 136,00 Ø 134		5216918 € 136,00 Ø 134		5216918 € 136,00 Ø 134		5216918 € 136,00 Ø 134	
-		-		-		2913137 € 20,99		-		-		-		-	
2911326 € 17,00		2911326 € 17,00		2911326 € 17,00		-		2911326 € 17,00		2911326 € 17,00		2911326 € 17,00		2911326 € 17,00	
2911326 € 17,00		2911326 € 17,00		2911326 € 17,00		2912779 (5 masses) € 21,00 2911326 (3 masses) € 15,94		2911326 € 17,00		2911326 € 17,00		2911326 € 17,00		2911326 € 17,00	

TEC1 ** ATTENTION ** PLEASE CHECK THE PROPER FITMENT : PAGE 416



MALOSSI

Maxi Scooter

125 → 800 4T

with ENGINE **GILERA**

DNA











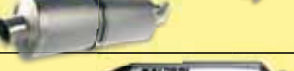





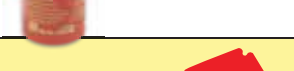















FUOCO
ie euro 3

GP

NEXUS
euro 3

(PIAGGIO M554M)

() CHECK "TYPE" SPECIFICATION (HOMOLOGATION MARK).180 4T **LC** 500 4T **LC** 800 4T **LC** 125 4T **LC**

	CLUTCH DISK SET FOR ORIGINAL CLUTCH		-	-	-	-
	MAXI WILD LION   HOMOLOGATED EXHAUST SYSTEM		-	3214374 *69* € 476,34	3214131 € 712,98	-
	RX   HOMOLOGATED EXHAUST SYSTEM		-	-	-	-
	RED CHILLI OIL OIL FILTER		0313382 € 7,00	0313383 € 7,42	0313383 € 7,42	0313382 € 7,00
	RED SPONGE FOR ORIGINAL AIR BOX		1411839 € 5,12	1412129 € 5,10	-	1412129 € 5,10
	DOUBLE RED SPONGE FOR ORIGINAL AIR BOX		-	1414496 € 7,35	-	1414496 € 7,35
	W BOX FOR ORIGINAL AIR BOX		-	-	-	-
	V FILTER VARIATOR AIR FILTER RIGHT SIDE		-	-	-	-
	POWER TRASMISSION		-	-	-	-
	GEARS HTQ PRIMARY		-	-	-	-
	GEARS HTQ SECONDARY		6712067 € 69,96 z 15/41	-	-	6712067 € 69,96 z 15/41
	SPORT SCREEN SCREEN		-	-	4514399 € 64,50	4513099 € 61,50
	MHR SCREEN SCREEN		-	-	-	-
	HOSE KIT FOR BRAKE		-	-	-	-
	BRAKE PADS FRONT ORGANIC BRAKE PADS		-	-	6215052 € 8,00	6215062 € 8,32
	BRAKE PADS MHR FRONT ORGANIC BRAKE PADS		-	-	6211525 € 8,20	6215079 € 8,20
	BRAKE PADS MHR SYNT FRONT SINTERED BRAKE PADS		6215011 € 16,00 2001->	-	6215020 € 16,00	6215013 € 16,50
	BRAKE PADS REAR ORGANIC BRAKE PADS		-	-	6215062 € 8,32	6215062 € 8,32
	BRAKE PADS MHR REAR ORGANIC BRAKE PADS		-	-	6215079 € 8,20	6215079 € 8,20
	BRAKE PADS MHR SYNT REAR SINTERED BRAKE PADS		6215015 € 16,64 2001->	-	6215013 € 16,50	6215013 € 16,50
	BRAKE POWER REAR BRAKE SHOES		-	-	-	-
	DISC / WHOOP DISC / PAIR WHOOP FRONT BRAKE DISC		6211702 2001-> € 83,67 6212351 2001-> € 88,30	-	-	6212352 € 95,83
	DISC / WHOOP DISC REAR BRAKE DISC		-	-	-	6212351 € 88,30
	TWINS MAXI SUSPENSIONS REAR PAIR SHOCK ABSORBER		-	4614789 € 261,00	-	-
	RS3 - RS1 REAR SHOCK ABSORBER		-	-	-	-
	RS24 REAR SHOCK ABSORBER		-	-	-	-
	RS24 FRONT SHOCK ABSORBER		-	-	-	-
	RS24 FRONT + REAR		-	-	-	-
	F32S FORK STEMS Ø 32		-	-	-	-
	F37R FORK STEMS Ø 37		-	-	-	-

69 - ONLY homologated SILENCER

GILERA

NEXUS ie euro 3		NEXUS ie euro 3		NEXUS ie euro 3		NEXUS ie euro 2-3		RUNNER ST euro 3		RUNNER ST euro 3		RUNNER VX <-2005		RUNNER VX 2006->	
125 4T	LC	250 4T	LC	300 4T	LC	500 4T	LC	125 4T	LC	200 4T	LC	125 4T	LC	125 4T	LC
-	-	-	-	-	-	-	-	-	-	-	-	-	-	-	-
-	-	-	-	-	-	3214374 *69* € 476,34	-	-	-	-	-	-	-	-	-
-	-	-	-	3215237 € 380,00	-	-	-	3215234 € 380,00	-	3215234 € 380,00	-	3215263 € 380,00	-	3215234 € 380,00	-
0313382 € 7,00	-	0313382 € 7,00	-	0313382 € 7,00	-	0313383 € 7,42	-	0313382 € 7,00	-	0313382 € 7,00	-	0313382 € 7,00	-	0313382 € 7,00	-
1412129 € 5,10	-	1412129 € 5,10	-	1412129 € 5,10	-	-	-	1412129 € 5,10	-	1412129 € 5,10	-	1411839 € 5,12	-	1412129 € 5,10	-
1414496 € 7,35	-	1414496 € 7,35	-	1414496 € 7,35	-	-	-	1414496 € 7,35	-	1414496 € 7,35	-	-	-	1414496 € 7,35	-
-	-	-	-	-	-	1413704 € 21,00	-	-	-	-	-	-	-	-	-
-	-	-	-	-	-	-	-	-	-	-	-	-	-	-	-
-	-	-	-	-	-	-	-	-	-	-	-	-	-	-	-
6712194 € 92,98 z 17/49	-	-	-	-	-	-	-	6711860 € 60,41 z 16/42	-	6711860 € 60,41 z 16/42	-	6711860 € 60,41 z 16/42	-	6711860 € 60,41 z 16/42	-
4513099 € 61,50	-	4513099 € 61,50	-	4513099 € 61,50	-	4513099 € 61,50	-	-	-	-	-	-	-	-	-
-	-	-	-	-	-	2213102 € 148,00	-	-	-	-	-	-	-	-	-
6215062 € 8,32	-	6215062 € 8,32	-	6215062 € 8,32	-	6215052 € 8,00	-	6215062 € 8,32	-	6215062 € 8,32	-	-	-	6215062 € 8,32	-
6215079 € 8,20	-	6215079 € 8,20	-	6215079 € 8,20	-	6211525 € 8,20	-	6215079 € 8,20	-	6215079 € 8,20	-	-	-	6215079 € 8,20	-
6215013 € 16,50	-	6215013 € 16,50	-	6215013 € 16,50	-	6215020 € 16,00	-	6215013 € 16,50	-	6215013 € 16,50	-	6215011 € 16,00 2001->	-	6215013 € 16,50	-
6215062 € 8,32	-	6215062 € 8,32	-	6215062 € 8,32	-	6216896 € 9,50	-	-	-	-	-	-	-	-	-
6215079 € 8,20	-	6215079 € 8,20	-	6215079 € 8,20	-	-	-	-	-	-	-	-	-	-	-
6215013 € 16,50	-	6215013 € 16,50	-	6215013 € 16,50	-	6215017 € 15,00	-	6215015 € 16,64	-	6215015 € 16,64	-	6215015 € 16,64 2001->	-	6215015 € 16,64	-
-	-	-	-	-	-	-	-	-	-	-	-	-	-	-	-
6212352 € 95,83	-	6212352 € 95,83	-	6212352 € 95,83	-	6212352 € 95,83	-	-	-	-	-	6212929 € 105,00 2001->	-	-	-
6212351 € 88,30	-	6212351 € 88,30	-	6212351 € 88,30	-	6212351 € 88,30	-	-	-	-	-	-	-	-	-
-	-	-	-	-	-	-	-	-	-	-	-	-	-	-	-
-	-	-	-	-	-	-	-	-	-	-	-	-	-	-	-
-	-	-	-	-	-	-	-	-	-	-	-	-	-	-	-
-	-	-	-	-	-	-	-	-	-	-	-	-	-	-	-
-	-	-	-	-	-	-	-	4613086 € 649,03	-	4613086 € 649,03	-	46 9627 € 688,26	-	4613086 € 649,03	-
-	-	-	-	-	-	-	-	4616136 € 1122,00	-	4616136 € 1122,00	-	4616135 € 1122,00	-	4616136 € 1122,00	-



MALOSSİ

Maxi Scooter

125 → 800 4T

with ENGINE 

GILERA			HONDA
RUNNER VXR	RUNNER VXR <-2005	RUNNER VXR 2006->	@
180 4T	LC	200 4T	LC
200 4T	LC	200 4T	LC
125 4T	LC		

Products to be used exclusively for racing in places specially designed for such activity according to the regulations of the competent sporting authorities. We accept no liability resulting from improper use.

	CYLINDER 4 STROKE ALUMINIUM	3113955 € 335,00 Ø 75,5	3113955 € 335,00 Ø 75,5	3113955 € 335,00 Ø 75,5	3111627 € 328,92 Ø 58
	CYLINDER I-TECH ALUMINIUM EQUIPPED WITH CDI	-	-	-	-
	POWER CAM CAMSHAFT	5911962 € 218,53	5911962 € 218,53	5911962 € 218,53	5912778 € 164,39
	HEAD V4 HEAD FOR ORIGINAL CYLINDER / MALOSSİ	*01*	*01*	*01*	-
	CYLINDER + V4 HEAD ALUMINIUM	-	-	-	-
	CYLINDER + V4 HEAD + POWER CAM ALUMINIUM Ø 75,5	3116208 € 895,00	3116208 € 895,00	3116208 € 895,00	-
	4 STROKE VALVE FOR ENGINE VALVES SET	2714047 € 118,53	2714047 € 118,53	2714047 € 118,53	-
	SPRINGS FOR ENGINE VALVES	2912834 € 21,54	2912834 € 21,54	2912834 € 21,54	-
	CRANKSHAFT RHQ	5312896 € 380,00	5312896 € 380,00	5312896 € 380,00	-
	IGNITION CONTROLLER DIGITRONIC FOR VEHICLES WITHOUT IMMOBILIZER	5512524 € 170,46	5512524 € 170,46	-	-
	IGNITION CONTROLLER DIGITRONIC FOR VEHICLES WITH IMMOBILIZER	5512341 € 170,46	5512341 € 170,46	5512341 € 170,46	-
	FORCE MASTER INJECTION CONTROLLER	-	-	-	-
	TC UNIT O2 controller LAMBDA EMULATOR	-	-	-	-
	MULTIVAR 2000 VARIATOR MULTIVAR 2000 MHR	5111594 € 112,35	5111885 € 112,35	5111885 € 112,35	5111572 € 112,35 5114065 € 122,57
	X SPECIAL BELT BELT X K BELT BELT	6115666 € 46,92	6115666 € 46,92	6115666 € 46,92	6114127 € 24,42 6116422 € 48,57
	HTRoll ROLLERS FOR MULTIVAR 2000 / MHR	6611095.R0 € 13,64 gr.14	6611095.R0 € 13,64 gr.14	6611095.R0 € 13,64 gr.14	6611095.G0+.FO € 13,64 gr.09,5+09 MHR
	HTRoll ROLLERS FOR ORIGINAL VARIATOR	66 9456.I0 € 12,00 gr.10,7	6613697.I0 € 18,00 gr.11	6613697.I0 € 18,00 gr.11	6611534.B0 € 11,00 gr.11,5
	VENTILVAR 2000 FIXED HALF-PULLEY	-	-	-	6112672 € 36,72
	VARIABLE-SPEED DRIVE ADJUSTER SPRING FOR VARIATOR	PG.445	PG.445	PG.445	PG.445
	TORSION CONTROLLER ANTIFRICTION FIFTH WHEEL	2513210 € 5,72	2513210 € 5,72	2513210 € 5,72	-
	TORQUE DRIVER MOBILE DRIVEN SPLIT PULLEY	6111656 € 123,88	6112563 2003-> € 197,30 6111656 <-2002 € 123,88	6112563 € 197,30	-
	OVER RANGE TRANSMISSION KIT	-	-	-	-
	MAXI FLY CLUTCH NOT ADJUSTABLE CLUTCH	-	-	-	5212522 € 70,37
	MAXI DELTA CLUTCH ADJUSTABLE CLUTCH	5211821 € 120,42	5211821 € 120,42	5211821 € 120,42	5212487 € 112,59
	MAXI CLUTCH BELL CLUTCH BELL (SMOOTH RING)	-	-	-	7714325 € 33,00 Ø 125
	MAXI WING CLUTCH BELL CLUTCH BELL (FINNED RING)	7715898B € 52,00 Ø 134	7715898B € 52,00 Ø 134	7715898B € 52,00 Ø 134	7713376 € 38,00 Ø 125
	MAXI FLY SYSTEM CLUTCH BELL + NOT ADJUSTABLE CLUTCH	-	-	-	5214724 € 100,47 Ø 125
	MAXI DELTA SYSTEM CLUTCH BELL + ADJUSTABLE CLUTCH	5216918 € 136,00 Ø 134	5216918 € 136,00 Ø 134	5216918 € 136,00 Ø 134	5216070 € 125,46 Ø 125
	SPRINGS FOR MAXI FLY CLUTCH	-	-	-	29 9605 € 16,20
	SPRINGS FOR MAXI DELTA CLUTCH	2911326 € 17,00	2911326 € 17,00	2911326 € 17,00	29 9605 € 16,20
	SPRINGS FOR ORIGINAL CLUTCH	2911326 € 17,00	2911326 € 17,00	2911326 € 17,00	2912536 € 15,56

01 - TO COUPLE ONLY with MALOSSİ CYLINDERS: 3813273 € 475,00

70 - For vehicles WITH ORIGINAL half-pulley "marked": "GF" 2911072.W0 - "FG" 2911074.Y0 € 10,71

HONDA

@	CN	DYLAN	DYLAN	FORESIGHT	FORZA 2001->	FORZA X <-2007	FORZA X 2008->
						(MF 08 E)	(MF 10 E)
150 4T LC	250 4T LC	125 4T LC	150 4T LC	250 4T LC	250 4T LC	250 4T LC	250 4T LC
3111588 €328,92 Ø 61	-	3111627 €328,92 Ø 58	3111588 €328,92 Ø 61	-	-	312956 €3200,00 Ø 77	-
-	-	-	-	-	-	-	-
5912778 €164,39	-	5912778 €164,39	5912778 €164,39	5911733 €152,00	5911733 €152,00	5911733 €152,00	-
-	-	-	-	-	-	-	-
-	-	-	-	-	-	-	-
-	-	-	-	2711826 €63,64	2711826 €63,64	2711826 €63,64	-
-	-	-	-	-	-	-	-
-	-	-	-	-	-	-	-
-	-	-	-	-	-	-	-
-	-	-	-	-	-	-	-
5111572 €112,35 5114065 €122,57	5113822 €119,13	5111572 €112,35 5114065 €122,57	5111572 €112,35 5114065 €122,57	5111226 €127,65	5111593 €127,65	5114261 €136,15	5113824 €136,15
6114127 €24,42 6116422 €48,57	61 9584 €39,82	6114127 €24,42 6116422 €48,57	6114127 €24,42 6116422 €48,57	6113189 €39,78	6113189 €39,78	6113104 €79,29	-
6611095.GO+.HO €13,64 gr.09,5 +10 MHR	66 9917.CO €19,12 gr.14	6611095.GO+.FO €13,64 gr.09,5 +09 MHR	6611095.GO+.HO €13,64 gr.09,5 +10 MHR	66 9917.MO €19,12 gr.18	66 9917.EO €19,12 gr.15	66 9917.MO €19,12 gr.18	66 9917.IO €19,12 gr.17
6611534.CO €11,00 gr.12,5	66 9915.DO €17,80 gr.23	6611534.BO €11,00 gr.11,5	6611534.CO €11,00 gr.12,5	66 9917.UO+.ZO €19,12 gr.25 1999-> +27 <-1998	-	-	66 9917.QO €19,12 gr.20
6112672 €36,72	-	6112672 €36,72	6112672 €36,72	6111347B €36,72	6111347B €36,72	-	-
PG.445	-	PG.445	PG.445	*70*	-	-	-
-	-	-	-	-	-	-	-
-	-	-	-	6111964 €177,16	6111964 €177,16	-	-
-	-	-	-	-	-	-	-
5212522 €70,37	-	5212522 €70,37	5212522 €70,37	-	-	-	-
5212487 €112,59	5211467 €129,23	5212487 €112,59	5212487 €112,59	5211467 €129,23	5211467 €129,23	5211467 €129,23	5211467 €129,23
7714325 €33,00 Ø 125	-	7714325 €33,00 Ø 125	7714325 €33,00 Ø 125	-	-	-	-
7713376 €38,00 Ø 125	-	7713376 €38,00 Ø 125	7713376 €38,00 Ø 125	7715916B €52,00 Ø 135	7715916B €52,00 Ø 135	7715916B €52,00 Ø 135	7715916B €52,00 Ø 135
5214724 €100,47 Ø 125	-	5214724 €100,47 Ø 125	5214724 €100,47 Ø 125	-	-	-	-
5216070 €125,46 Ø 125	-	5216070 €125,46 Ø 125	5216070 €125,46 Ø 125	5216184 €136,00 Ø 135	5216184 €136,00 Ø 135	5216184 €136,00 Ø 135	5216184 €136,00 Ø 135
29 9605 €16,20	-	29 9605 €16,20	29 9605 €16,20	-	-	-	-
29 9605 €16,20	2911326 €17,00	29 9605 €16,20	29 9605 €16,20	2911326 €17,00	2911326 €17,00	2911326 €17,00	2911326 €17,00
2912536 €15,56	2911326 €17,00	2912536 €15,56	2912536 €15,56	2911326 €17,00	2911326 €17,00	2911326 €17,00	2911326 €17,00

MAXI SCOOTER 125 → 800 4T



MALOSSI

Maxi Scooter

125 → 800 4T

with ENGINE **GILERA****HONDA**

RUNNER VXR

RUNNER VXR
<-2005RUNNER VXR
2006->

@

() CHECK "TYPE" SPECIFICATION (HOMOLOGATION MARK).

180 4T

LC

200 4T











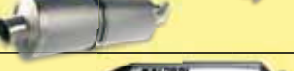

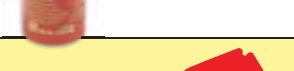













LC

200 4T

LC

125 4T

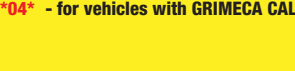
LC

	CLUTCH DISK SET FOR ORIGINAL CLUTCH		-	-	-	-
	MAXI WILD LION () HOMOLOGATED EXHAUST SYSTEM	PG. 418	-	-	-	-
	RX () HOMOLOGATED EXHAUST SYSTEM	PG. 420	-	3215263 € 380,00	3215234 € 380,00	3214796 € 380,00
	RED CHILLI OIL OIL FILTER		0313382 € 7,00	0313382 € 7,00	0313382 € 7,00	-
	RED SPONGE FOR ORIGINAL AIR BOX		1411839 € 5,12	1412129 € 5,10	1412129 € 5,10	-
	DOUBLE RED SPONGE FOR ORIGINAL AIR BOX		-	1414496 € 7,35	1414496 € 7,35	-
	W BOX FOR ORIGINAL AIR BOX		-	-	-	1415333 € 45,00
	V FILTER VARIATOR AIR FILTER RIGHT SIDE		-	-	-	-
	POWER TRASMISSION		-	-	-	-
	GEARS HTQ PRIMARY		-	-	-	6712497 € 97,48 z 14/45
	GEARS HTQ SECONDARY		6711860 € 60,41 z 16/42	6711860 € 60,41 z 16/42	6711860 € 60,41 z 16/42	-
	SPORT SCREEN SCREEN		-	-	-	-
	MHR SCREEN SCREEN		-	-	-	-
	HOSE KIT FOR BRAKE		-	-	-	-
	BRAKE PADS FRONT ORGANIC BRAKE PADS		-	-	6215062 € 8,32	-
	BRAKE PADS MHR FRONT ORGANIC BRAKE PADS		-	-	6215079 € 8,20	-
	BRAKE PADS MHR SYNT FRONT SINTERED BRAKE PADS		6215011 *04* € 16,00 2001->	6215011 *04* € 16,00 2001->05	6215013 € 16,50	6215018 € 15,60 2000
	BRAKE PADS REAR ORGANIC BRAKE PADS		-	-	-	-
	BRAKE PADS MHR REAR ORGANIC BRAKE PADS		-	-	-	-
	BRAKE PADS MHR SYNT REAR SINTERED BRAKE PADS		6215015 € 16,64 2001->	-	6215015 € 16,64	-
	BRAKE POWER REAR BRAKE SHOES		-	-	-	-
	DISC / WHOOP DISC / PAIR WHOOP FRONT BRAKE DISC		6212929 € 105,00 2001->	6212929 € 105,00	-	-
	DISC / WHOOP DISC REAR BRAKE DISC		-	-	-	-
	TWINS MAXI SUSPENSIONS REAR PAIR SHOCK ABSORBER		-	-	-	4613162 € 246,00
	RS3 - RS1 REAR SHOCK ABSORBER		-	-	-	-
	RS24 REAR SHOCK ABSORBER		-	-	-	-
	RS24 FRONT SHOCK ABSORBER		-	-	-	-
	RS24 FRONT + REAR		-	-	-	-
	F32S FORK STEMS Ø 32		46 9627 € 688,26	46 9627 € 688,26	4613086 € 649,03	-
	F37R FORK STEMS Ø 37		4616135 € 1122,00	4616135 € 1122,00	4616136 € 1122,00	-

04 - for vehicles with GRIMECA CALIPER

HONDA

@	CN	DYLAN	DYLAN	FORESIGHT	FORZA 2001->	FORZA X <-2007	FORZA X 2008->
						(MF 08 E)	(MF 10 E)
150 4T LC	250 4T LC	125 4T LC	150 4T LC	250 4T LC	250 4T LC	250 4T LC	250 4T LC
-	-	-	-	-	-	-	-
-	-	-	-	-	-	-	-
3214796 € 380,00	-	3214796 € 380,00	3214796 € 380,00	-	-	-	-
-	-	-	-	-	-	-	-
-	-	-	-	-	-	-	-
-	-	-	-	-	-	-	-
1415333 € 45,00	-	1415333 € 45,00	1415333 € 45,00	-	-	-	-
-	-	-	-	-	-	-	-
-	-	-	-	-	-	-	-
6712497 € 97,48 z 14/45	-	6712497 € 97,48 z 14/45	6712497 € 97,48 z 14/45	-	-	-	-
-	-	-	-	67 9983 € 90,27 z 17/37	67 9983 € 90,27 z 17/37	-	-
-	-	-	-	-	-	-	-
-	-	-	-	-	-	-	-
-	6211522 € 9,10 1993->	-	-	-	-	-	-
-	6211523 € 9,50 1993->	-	-	-	-	-	-
6215018 € 15,60 2000->	-	-	-	6215032 € 20,00 1999->	6215032 € 20,00 2001->	6215034 € 18,62	6215034 € 18,62
-	-	-	-	-	-	6216891 € 10,24	6216891 € 10,24
-	-	-	-	-	-	-	-
-	-	-	-	-	-	6215016 € 16,64	6215016 € 16,64
-	-	-	-	-	-	-	-
-	-	-	-	6212342 € 87,50 1997->	6212342 € 87,50 2001->	6212342 € 87,50	6212343 € 99,00
-	-	-	-	-	-	6212342 € 87,50	6212342 € 87,50
4613162 € 246,00	-	4613162 € 246,00	4613162 € 246,00	-	-	-	-
-	-	-	-	-	-	-	-
-	-	-	-	-	-	-	-
-	-	-	-	-	-	-	-
-	-	-	-	-	-	-	-
-	-	-	-	-	-	-	-
-	-	-	-	-	-	-	-
-	-	-	-	-	-	-	-



MALOSSI

Maxi Scooter

125 → 800 4T

with ENGINE **HONDA**FORZA ABS
ieINTEGRA
ieINTEGRA
ieJAZZ
2001->

(NF04E)

300 4T

LC

700 4T

LC

750 4T

LC

250 4T

LC

Products to be used exclusively for racing in places specially designed for such activity according to the regulations of the competent sporting authorities. We accept no liability resulting from improper use.

	CYLINDER 4 STROKE ALUMINIUM	-	-	-	-
	CYLINDER I-TECH ALUMINIUM EQUIPPED WITH CDI	-	-	-	-
	POWER CAM CAMSHAFT	5914657 € 216,30	-	-	5911733 € 152,00
	HEAD V4 HEAD FOR ORIGINAL CYLINDER / MALOSSI	-	-	-	-
	CYLINDER + V4 HEAD ALUMINIUM	-	-	-	-
	CYLINDER + V4 HEAD + POWER CAM ALUMINIUM Ø 75,5	-	-	-	-
	4 STROKE VALVE FOR ENGINE VALVES SET	-	-	-	2711826 € 63,64
	SPRINGS FOR ENGINE VALVES	2914680 € 13,39	-	-	-
	CRANKSHAFT RHQ	-	-	-	-
	IGNITION CONTROLLER DIGITRONIC FOR VEHICLES WITHOUT IMMOBILIZER	-	-	-	-
	IGNITION CONTROLLER DIGITRONIC FOR VEHICLES WITH IMMOBILIZER	-	-	-	-
	FORCE MASTER INJECTION CONTROLLER	-	-	-	-
	TC UNIT O2 controller LAMBDA EMULATOR	-	-	-	-
	MULTIVAR 2000 VARIATOR MULTIVAR 2000 MHR	5113398 € 136,15 5114192 € 144,20	-	-	5111593 € 127,65
	X SPECIAL BELT BELT X K BELT BELT	6113590 € 97,21	-	-	6113189 € 39,78
	HTRoll ROLLERS FOR MULTIVAR 2000 / MHR	66 9917.J0+.A0 € 19,12 J0 gr.11 +.CO 14 gr.12 MHR	-	-	66 9917.E0 € 19,12 gr.15
	HTRoll ROLLERS FOR ORIGINAL VARIATOR	66 9917.Q0 € 19,12 gr.20	-	-	-
	VENTILVAR 2000 FIXED HALF-PULLEY	6113523B € 44,88	-	-	6111347B € 36,72
	VARIABLE-SPEED DRIVE ADJUSTER SPRING FOR VARIATOR	PG. 445 PG.445	-	-	-
	TORSION CONTROLLER ANTIFRICTION FIFTH WHEEL	-	-	-	-
	TORQUE DRIVER MOBILE DRIVEN SPLIT PULLEY	-	-	-	6111964 € 177,16
	OVER RANGE TRANSMISSION KIT	-	-	-	-
	MAXI FLY CLUTCH NOT ADJUSTABLE CLUTCH	-	-	-	-
	MAXI DELTA CLUTCH ADJUSTABLE CLUTCH	5211467 € 129,23	-	-	5211467 € 129,23
	MAXI CLUTCH BELL CLUTCH BELL (SMOOTH RING)	7715916B € 52,00 Ø 135	-	-	7715916B € 52,00 Ø 135
	MAXI WING CLUTCH BELL CLUTCH BELL (FINNED RING)	-	-	-	-
	MAXI FLY SYSTEM CLUTCH BELL + NOT ADJUSTABLE CLUTCH	-	-	-	-
	MAXI DELTA SYSTEM CLUTCH BELL + ADJUSTABLE CLUTCH	5216184 € 136,00 Ø 135	-	-	5216184 € 136,00 Ø 135
	SPRINGS FOR MAXI FLY CLUTCH	-	-	-	-
	SPRINGS FOR MAXI DELTA CLUTCH	2911326 € 17,00	-	-	2911326 € 17,00
	SPRINGS FOR ORIGINAL CLUTCH	2911326 € 17,00	-	-	2911326 € 17,00

HONDA

PANTHEON ie		PANTHEON ie		PCX ie euro 3 <-2011		PCX ie euro 3 2012->		PCX ie euro 3 <-2013		PCX ie euro 3 2014->		PS ie euro 3		PS ie euro 3	
				(JF28E)		(JF47)		(KF12E)		(KF19E)					
125 4T	LC	150 4T	LC	125 4T	LC	125 4T	LC	150 4T	LC	150 4T	LC	125 4T	LC	150 4T	LC
3111627 €328,92 Ø 58		3111588 €328,92 Ø 61		-		-		-		-		3111627 €328,92 Ø 58		3111588 €328,92 Ø 61	
-		-		-		-		-		-		-		-	
-		-		-		-		-		-		-		-	
-		-		-		-		-		-		-		-	
-		-		-		-		-		-		-		-	
-		-		-		-		-		-		-		-	
-		-		-		-		-		-		-		-	
-		-		-		-		-		-		-		-	
-		-		-		-		-		-		-		-	
-		-		-		-		-		-		-		-	
5514778 €240,14		5515226 €240,14		-		-		-		-		5514778 €240,14		5515226 €240,14	
5514750 €84,00		5514750 €84,00		-		-		-		-		5514750 €84,00		5514750 €84,00	
5111572 €112,35 5114065 €122,57		5111572 €112,35 5114065 €122,57		5115552 €110,68		5115552 €110,68		5115552 €110,68		5115552 €110,68		5111572 €112,35 5114065 €122,57		5111572 €112,35 5114065 €122,57	
6114127 €24,42 6116422 €48,57		6114127 €24,42 6116422 €48,57		6114895 €43,86		6114895 €43,86		-		-		6114127 €24,42 6116422 €48,57		6114127 €24,42 6116422 €48,57	
6611095.G0+.FO €13,64 gr.09,5 +09 MHR		6611095.G0+.HO €13,64 gr.09,5 +10 MHR		6611095.I0 €13,64 gr.10,5		6611095.I0 €13,64 gr.10,5		6611095.00 €13,64 gr.12,5		6611095.00 €13,64 gr.12,5		6611095.G0+.FO €13,64 gr.09,5 +09 MHR		6611095.G0+.HO €13,64 gr.09,5 +10 MHR	
6611534.B0 €11,00 gr.11,5		-		6611534.F0 €11,00 gr.14,5		6611534.F0 €11,00 gr.14,5		6611534.N0 €11,00 gr.17,5		6611534.H0 €11,00 gr.15,5		6611534.B0 €11,00 gr.11,5		6611534.C0 €11,00 gr.12,5	
6112672 €36,72		6112672 €36,72		-		-		-		-		6112672 €36,72		6112672 €36,72	
PG.445		PG.445		PG.445		PG.445		PG.445		PG.445		PG.445		PG.445	
-		-		-		-		-		-		-		-	
-		-		-		-		-		-		-		-	
-		-		-		-		-		-		-		-	
5212522 €70,37		5212522 €70,37		5212522 €70,37		5212522 €70,37		5212522 €70,37		5212522 €70,37		5212522 €70,37		5212522 €70,37	
5212487 €112,59		5212487 €112,59		5212487 €112,59		5212487 €112,59		5212487 €112,59		5212487 €112,59		5212487 €112,59		5212487 €112,59	
7714325 €33,00 Ø 125		7714325 €33,00 Ø 125		7714325 €33,00 Ø 125		7714325 €33,00 Ø 125		7714325 €33,00 Ø 125		7714325 €33,00 Ø 125		7714325 €33,00 Ø 125		7714325 €33,00 Ø 125	
7713376 €38,00 Ø 125		7713376 €38,00 Ø 125		7713376 €38,00 Ø 125		7713376 €38,00 Ø 125		7713376 €38,00 Ø 125		7713376 €38,00 Ø 125		7713376 €38,00 Ø 125		7713376 €38,00 Ø 125	
5214724 €100,47 Ø 125		5214724 €100,47 Ø 125		5214724 €100,47 Ø 125		5214724 €100,47 Ø 125		5214724 €100,47 Ø 125		5214724 €100,47 Ø 125		5214724 €100,47 Ø 125		5214724 €100,47 Ø 125	
5216070 €125,46 Ø 125		5216070 €125,46 Ø 125		5216070 €125,46 Ø 125		5216070 €125,46 Ø 125		5216070 €125,46 Ø 125		5216070 €125,46 Ø 125		5216070 €125,46 Ø 125		5216070 €125,46 Ø 125	
29 9605 €16,20		29 9605 €16,20		29 9605 €16,20		29 9605 €16,20		29 9605 €16,20		29 9605 €16,20		29 9605 €16,20		29 9605 €16,20	
29 9605 €16,20		29 9605 €16,20		29 9605 €16,20		29 9605 €16,20		29 9605 €16,20		29 9605 €16,20		29 9605 €16,20		29 9605 €16,20	
2912536 €15,56		2912536 €15,56		2912536 €15,56		2912536 €15,56		2912536 €15,56		2912536 €15,56		2912536 €15,56		2912536 €15,56	



MALOSSI

Maxi Scooter

125 → 800 4T

with ENGINE **HONDA**FORZA ABS
ieINTEGRA
ieINTEGRA
ieJAZZ
2001->

(NF04E)

300 4T

LC

700 4T

LC











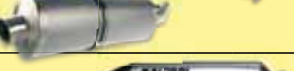





















750 4T

LC

250 4T

LC

() CHECK "TYPE" SPECIFICATION (HOMOLOGATION MARK).

	CLUTCH DISK SET FOR ORIGINAL CLUTCH		-	-	-	-
	MAXI WILD LION  HOMOLOGATED EXHAUST SYSTEM		-	-	-	-
	RX  HOMOLOGATED EXHAUST SYSTEM		-	-	-	-
	RED CHILLI OIL OIL FILTER		0313827 € 8,00	-	-	-
	RED SPONGE FOR ORIGINAL AIR BOX		-	-	-	-
	DOUBLE RED SPONGE FOR ORIGINAL AIR BOX		-	-	-	-
	W BOX FOR ORIGINAL AIR BOX		1415334 € 45,00	-	-	-
	V FILTER VARIATOR AIR FILTER RIGHT SIDE		-	-	-	-
	POWER TRASMISSION		-	-	-	-
	GEARS HTQ PRIMARY		-	-	-	-
	GEARS HTQ SECONDARY		-	-	-	67 9983 € 90,27 z 17/37
	SPORT SCREEN SCREEN		-	4515621B € 61,50	4515621B € 61,50	-
	MHR SCREEN SCREEN		-	-	-	-
	HOSE KIT FOR BRAKE		-	-	-	-
	BRAKE PADS FRONT ORGANIC BRAKE PADS		-	-	-	-
	BRAKE PADS MHR FRONT ORGANIC BRAKE PADS		-	-	-	-
	BRAKE PADS MHR SYNT FRONT SINTERED BRAKE PADS		6215034 € 18,62	-	-	6215032 € 20,00 2001->
	BRAKE PADS REAR ORGANIC BRAKE PADS		6216891 € 10,24	-	-	-
	BRAKE PADS MHR REAR ORGANIC BRAKE PADS		-	-	-	-
	BRAKE PADS MHR SYNT REAR SINTERED BRAKE PADS		6215016 € 16,64	-	-	-
	BRAKE POWER REAR BRAKE SHOES		-	-	-	-
	DISC / WHOOP DISC / PAIR WHOOP FRONT BRAKE DISC		6212343 € 99,00	-	-	6212342 € 87,50 2001->
	DISC / WHOOP DISC REAR BRAKE DISC		6212342 € 87,50	-	-	-
	TWINS MAXI SUSPENSIONS REAR PAIR SHOCK ABSORBER		4614007 € 250,00	-	-	-
	RS3 - RS1 REAR SHOCK ABSORBER		-	-	-	-
	RS24 REAR SHOCK ABSORBER		-	-	-	-
	RS24 FRONT SHOCK ABSORBER		-	-	-	-
	RS24 FRONT + REAR		-	-	-	-
	F32S FORK STEMS Ø 32		-	-	-	-
	F37R FORK STEMS Ø 37		-	-	-	-

HONDA

PANTHEON ie		PANTHEON ie		PCX ie euro 3 <-2011		PCX ie euro 3 2012->		PCX ie euro 3 <-2013		PCX ie euro 3 2014->		PS ie euro 3		PS ie euro 3	
				(JF28E)		(JF47)		(KF12E)		(KF19E)					
125 4T	LC	150 4T	LC	125 4T	LC	125 4T	LC	150 4T	LC	150 4T	LC	125 4T	LC	150 4T	LC
-		-		-		-		-		-		-		-	
-		-		-		-		-		-		-		-	
-		-		3215110 <i>€ 380,00</i>		3215554 <i>€ 380,00</i>		3215554 <i>€ 380,00</i>		3215554 <i>€ 380,00</i>		3214796 <i>€ 380,00</i>		3214796 <i>€ 380,00</i>	
-		-		-		-		-		-		-		-	
-		-		-		-		-		-		-		-	
-		-		-		-		-		-		-		-	
-		-		-		-		-		-		1415333 <i>€ 45,00</i>		1415333 <i>€ 45,00</i>	
-		-		-		-		-		-		-		-	
-		-		-		-		-		-		-		-	
6712497 <i>€ 97,48 z 14/45</i>		6712570 <i>€ 92,77 z 16/44</i>		-		-		-		-		6712497 <i>€ 97,48 z 14/45</i>		6712497 <i>€ 97,48 z 14/45</i>	
-		-		-		-		-		-		-		-	
-		-		-		-		-		-		-		-	
-		-		-		-		-		-		-		-	
-		-		-		-		-		-		-		-	
-		-		-		-		-		-		6215018 <i>€ 15,60</i>		6215018 <i>€ 15,60</i>	
-		-		-		-		-		-		-		-	
-		-		-		-		-		-		-		-	
6215032 <i>€ 20,00</i>		6215032 <i>€ 20,00</i>		-		-		-		-		-		-	
-		-		-		-		-		-		-		-	
-		-		-		-		-		-		-		-	
-		-		-		-		-		-		-		-	
-		-		-		-		-		-		-		-	
-		-		-		-		-		-		-		-	
-		-		-		-		-		-		-		-	
-		-		-		-		-		-		-		-	
-		-		-		-		-		-		-		-	
-		-		-		-		-		-		-		-	

MAXI SCOOTER 125 → 800 4T





MALOSSI

Maxi Scooter

125 → 800 4T

with ENGINE **HONDA**REFLEX
2001->

SH - SH Scoopy

SH I
ie
<-2008SH I
ie euro 3
2009->

(JF14E)

250 4T

LC

125 4T

LC

125 4T

LC

125 4T

LC

	CYLINDER 4 STROKE ALUMINIUM	-	3111627 € 328,92 Ø 58	3111627 € 328,92 Ø 58	3111627 € 328,92 Ø 58
	CYLINDER I-TECH ALUMINIUM EQUIPPED WITH CDI	-	-	-	-
	POWER CAM CAMSHAFT	5911733 € 152,00	5912778 € 164,39	*05*	*05*
	HEAD V4 HEAD FOR ORIGINAL CYLINDER / MALOSSI	-	-	-	-
	CYLINDER + V4 HEAD ALUMINIUM	-	-	-	-
	CYLINDER + V4 HEAD + POWER CAM ALUMINIUM Ø 75,5	-	-	-	-
	4 STROKE VALVE FOR ENGINE VALVES SET	2711826 € 63,64	-	-	-
	SPRINGS FOR ENGINE VALVES	-	-	-	-
	CRANKSHAFT RHQ	-	-	-	-
	IGNITION CONTROLLER DIGITRONIC FOR VEHICLES WITHOUT IMMOBILIZER	-	-	-	-
	IGNITION CONTROLLER DIGITRONIC FOR VEHICLES WITH IMMOBILIZER	-	-	-	-
	FORCE MASTER INJECTION CONTROLLER	-	-	5514778 € 240,14	5514778 € 240,14
	TC UNIT 02 controller LAMBDA EMULATOR	-	-	5514750 € 84,00	5514750 € 84,00
	MULTIVAR 2000 VARIATOR MULTIVAR 2000 MHR	5111593 € 127,65	5111572 € 112,35 5114065 € 122,57	5111572 € 112,35 5114065 € 122,57	5111572 € 112,35 5114065 € 122,57
	X SPECIAL BELT BELT X K BELT BELT	6113189 € 39,78	6114127 € 24,42 6116422 € 48,57	6114127 € 24,42 6116422 € 48,57	6114127 € 24,42 6116422 € 48,57
	HTRoll ROLLERS FOR MULTIVAR 2000 / MHR	66 9917.E0 € 19,12 gr.15	6611095.G0+.FO € 13,64 gr.09,5 +09 MHR	6611095.G0+.FO € 13,64 gr.09,5 +09 MHR	6611095.G0+.FO € 13,64 gr.09,5 +09 MHR
	HTRoll ROLLERS FOR ORIGINAL VARIATOR	-	6611534.B0 € 11,00 gr.11,5	6611534.A0 € 11,00 gr.10,5	6611534.A0 € 11,00 gr.10,5
	VENTILVAR 2000 FIXED HALF-PULLEY	6111347B € 36,72	6112672 € 36,72	6112672 € 36,72	6112672 € 36,72
	VARIABLE-SPEED DRIVE ADJUSTER SPRING FOR VARIATOR	PG.445	PG.445	PG.445	PG.445
	TORSION CONTROLLER ANTIFRICTION FIFTH WHEEL	-	-	-	-
	TORQUE DRIVER MOBILE DRIVEN SPLIT PULLEY	6111964 € 177,16	-	-	-
	OVER RANGE TRANSMISSION KIT	-	-	-	-
	MAXI FLY CLUTCH NOT ADJUSTABLE CLUTCH	-	5212522 € 70,37	5212522 € 70,37	5212522 € 70,37
	MAXI DELTA CLUTCH ADJUSTABLE CLUTCH	5211467 € 129,23	5212487 € 112,59	5212487 € 112,59	5212487 € 112,59
	MAXI CLUTCH BELL CLUTCH BELL (SMOOTH RING)	7715916B € 52,00 Ø 135	7714325 € 33,00 Ø 125	7714325 € 33,00 Ø 125	7714325 € 33,00 Ø 125
	MAXI WING CLUTCH BELL CLUTCH BELL (FINNED RING)	-	7713376 € 38,00 Ø 125	7713376 € 38,00 Ø 125	7713376 € 38,00 Ø 125
	MAXI FLY SYSTEM CLUTCH BELL + NOT ADJUSTABLE CLUTCH	-	5214724 € 100,47 Ø 125	5214724 € 100,47 Ø 125	5214724 € 100,47 Ø 125
	MAXI DELTA SYSTEM CLUTCH BELL + ADJUSTABLE CLUTCH	5216184 € 136,00 Ø 135	5216070 € 125,46 Ø 125	5216070 € 125,46 Ø 125	5216070 € 125,46 Ø 125
	SPRINGS FOR MAXI FLY CLUTCH	-	29 9605 € 16,20	29 9605 € 16,20	29 9605 € 16,20
	SPRINGS FOR MAXI DELTA CLUTCH	2911326 € 17,00	29 9605 € 16,20	29 9605 € 16,20	29 9605 € 16,20
	SPRINGS FOR ORIGINAL CLUTCH	2911326 € 17,00	2912536 € 15,56	2912536 € 15,56	2912536 € 15,56

05 - ONLY for vehicles WITH Malossi CYLINDER AND FORCE MASTER electr. contr.: 5912778 € 164,39

HONDA

91

SH i ABS ie euro 3 2013->	SH mode ie euro 3	SH - SH Scoopy	SH I ie <-2008	SH I ie euro 3 2009->	SH i ABS ie euro 3 2013->	SH I - SH I Scoopy ie <-2010	SH I - SH I Scoopy ie 2011->2014
(JF41E)	(JF51E)			(KF08E)	(KF13E)	(NF02E)	(NF02E)
125 4T LC	125 4T LC	150 4T LC	150 4T LC	150 4T LC	150 4T LC	300 4T LC	300 4T LC
-	-	3111588 € 328,92 Ø 61	3111588 € 328,92 Ø 61	3111588 € 328,92 Ø 61	-	-	-
-	-	-	-	-	-	-	-
-	-	5912778 € 164,39	-	-	-	5914657 € 216,30	5914657 € 216,30
-	-	-	-	-	-	-	-
-	-	-	-	-	-	-	-
-	-	-	-	-	-	-	-
-	-	-	-	-	-	2914680 € 13,39	2914680 € 13,39
-	-	-	-	-	-	-	-
-	-	-	-	-	-	-	-
-	-	-	5515226 € 240,14	5515226 € 240,14	-	5514754 € 232,96	5514754 € 232,96
5516458 € 89,00	-	-	5514750 € 84,00	5514750 € 84,00	5516458 € 89,00	5515734 € 90,00	5515734 € 90,00
5115652 € 122,57	5115552 € 110,68	5111572 € 112,35 5114065 € 122,57	5111572 € 112,35 5114065 € 122,57	5111572 € 112,35 5114065 € 122,57	5115652 € 122,57	5113398 € 136,15 5114192 € 144,20	5113398 € 136,15 5114192 € 144,20
6115676 € 32,64	6114895 € 43,86	6114127 € 24,42 6116422 € 48,57	6114127 € 24,42 6116422 € 48,57	6114127 € 24,42 6116422 € 48,57	6115676 € 32,64	6113590 € 97,21	6113590 € 97,21
-	6611095.I0 € 13,64 gr.10,5	6611095.G0+.HO € 13,64 gr.09,5 +10 MHR	6611095.G0+.HO € 13,64 gr.09,5 +10 MHR	6611095.G0+.HO € 13,64 gr.09,5 +10 MHR	-	66 9917.J0+.AO € 19,12 J0 gr.11 +C0 14 gr.12 MHR	66 9917.J0+.AO € 19,12 J0 gr.11 +C0 14 gr.12 MHR
6611534.HO € 11,00 gr.15,5	-	6611534.C0 € 11,00 gr.12,5	6611534.C0 € 11,00 gr.12,5	6611534.C0 € 11,00 gr.12,5	6611534.N0 € 11,00 gr.17,5	66 9917.O0 € 19,12 gr.19	66 9917.O0 € 19,12 gr.19
-	-	6112672 € 36,72	6112672 € 36,72	6112672 € 36,72	-	6113523B € 44,88	6113523B € 44,88
PG.445	PG.445	PG.445	PG.445	PG.445	PG.445	PG.445	PG.445
-	-	-	-	-	-	-	-
-	-	-	-	-	-	-	-
-	-	-	-	-	-	-	-
5212522 € 70,37	5212522 € 70,37	5212522 € 70,37	5212522 € 70,37	5212522 € 70,37	5212522 € 70,37	-	-
5212487 € 112,59	5212487 € 112,59	5212487 € 112,59	5212487 € 112,59	5212487 € 112,59	5212487 € 112,59	5211467 € 129,23	5211467 € 129,23
7714325 € 33,00 Ø 125	7714325 € 33,00 Ø 125	7714325 € 33,00 Ø 125	7714325 € 33,00 Ø 125	7714325 € 33,00 Ø 125	7714325 € 33,00 Ø 125	7715916B € 52,00 Ø 135	7715916B € 52,00 Ø 135
7713376 € 38,00 Ø 125	7713376 € 38,00 Ø 125	7713376 € 38,00 Ø 125	7713376 € 38,00 Ø 125	7713376 € 38,00 Ø 125	7713376 € 38,00 Ø 125	-	-
5214724 € 100,47 Ø 125	5214724 € 100,47 Ø 125	5214724 € 100,47 Ø 125	5214724 € 100,47 Ø 125	5214724 € 100,47 Ø 125	5214724 € 100,47 Ø 125	-	-
5216070 € 125,46 Ø 125	5216070 € 125,46 Ø 125	5216070 € 125,46 Ø 125	5216070 € 125,46 Ø 125	5216070 € 125,46 Ø 125	5216070 € 125,46 Ø 125	5216184 € 136,00 Ø 135	5216184 € 136,00 Ø 135
29 9605 € 16,20	29 9605 € 16,20	29 9605 € 16,20	29 9605 € 16,20	29 9605 € 16,20	29 9605 € 16,20	-	-
29 9605 € 16,20	29 9605 € 16,20	29 9605 € 16,20	29 9605 € 16,20	29 9605 € 16,20	29 9605 € 16,20	2911326 € 17,00	2911326 € 17,00
2912536 € 15,56	2912536 € 15,56	2912536 € 15,56	2912536 € 15,56	2912536 € 15,56	2912536 € 15,56	2911326 € 17,00	2911326 € 17,00

MAXI SCOOTER 125 → 800 4T



MALOSSİ

Maxi Scooter

125 → 800 4T











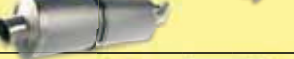







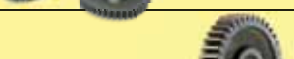



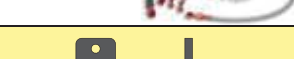





with ENGINE **HONDA**REFLEX
2001->

SH - SH Scoopy

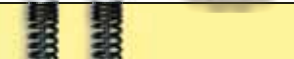
SH I
ie
<-2008SH I
ie euro 3
2009->

(JF14E)

() CHECK "TYPE" SPECIFICATION (HOMOLOGATION MARK).250 4T **LC** 125 4T **LC** 125 4T **LC** 125 4T **LC**

	CLUTCH DISK SET FOR ORIGINAL CLUTCH		-	-	-	-
	MAXI WILD LION () HOMOLOGATED EXHAUST SYSTEM	PG. 418	-	-	-	-
	RX () HOMOLOGATED EXHAUST SYSTEM	PG. 420	-	3214796 € 380,00	3214796 € 380,00	3214796 € 380,00
	RED CHILLI OIL OIL FILTER		-	-	-	-
	RED SPONGE FOR ORIGINAL AIR BOX		-	-	-	-
	DOUBLE RED SPONGE FOR ORIGINAL AIR BOX		-	-	-	-
	W BOX FOR ORIGINAL AIR BOX		-	1415333 € 45,00	1415333 € 45,00	1415333 € 45,00
	V FILTER VARIATOR AIR FILTER RIGHT SIDE		-	-	-	-
	POWER TRASMISSION		-	-	-	-
	GEARS HTQ PRIMARY		-	-	-	-
	GEARS HTQ SECONDARY		67 9983 € 90,27 z 17/37	-	-	-
	SPORT SCREEN SCREEN		-	-	4514611 € 56,00	4514608 € 56,00
	MHR SCREEN SCREEN		-	-	-	-
	HOSE KIT FOR BRAKE		-	-	-	-
	BRAKE PADS FRONT ORGANIC BRAKE PADS		-	-	-	-
	BRAKE PADS MHR FRONT ORGANIC BRAKE PADS		-	-	-	-
	BRAKE PADS MHR SYNT FRONT SINTERED BRAKE PADS		6215032 € 20,00 2001->	6215018 € 15,60 2000	6215018 € 15,60	6215034 € 18,62
	BRAKE PADS REAR ORGANIC BRAKE PADS		-	-	-	-
	BRAKE PADS MHR REAR ORGANIC BRAKE PADS		-	-	-	-
	BRAKE PADS MHR SYNT REAR SINTERED BRAKE PADS		-	-	-	-
	BRAKE POWER REAR BRAKE SHOES		-	-	-	-
	DISC / WHOOP DISC / PAIR WHOOP FRONT BRAKE DISC		6212342 € 87,50	-	-	6212342 € 87,50
	DISC / WHOOP DISC REAR BRAKE DISC		-	-	-	6212342 € 87,50
	TWINS MAXI SUSPENSIONS REAR PAIR SHOCK ABSORBER		-	4613162 € 246,00	4613162 € 246,00	4613162 € 246,00
	RS3 - RS1 REAR SHOCK ABSORBER		-	-	-	-
	RS24 REAR SHOCK ABSORBER		-	-	-	-
	RS24 FRONT SHOCK ABSORBER		-	-	-	-
	RS24 FRONT + REAR		-	-	-	-
	F32S FORK STEMS Ø 32		-	-	-	-
	F37R FORK STEMS Ø 37		-	-	-	-

HONDA

SH i ABS ie euro 3 2013->	SH mode ie euro 3	SH - SH Scoopy	SH I ie <-2008	SH I ie euro 3 2009->	SH i ABS ie euro 3 2013->	SH I - SH I Scoopy ie <-2010	SH I - SH I Scoopy ie 2011->2014
(JF41E)	(JF51E)			(KF08E)	(KF13E)	(NF02E)	(NF02E)
125 4T LC	125 4T LC	150 4T LC	150 4T LC	150 4T LC	150 4T LC	300 4T LC	300 4T LC
-	-	-	-	-	-	-	-
-	-	-	-	-	-	-	-
3215557 € 380,00	-	3214796 € 380,00	3214796 € 380,00	3214796 € 380,00	3215557 € 380,00	3214800 € 380,00	3214800 € 380,00
-	-	-	-	-	-	0313827 € 8,00	0313827 € 8,00
-	-	-	-	-	-	-	-
-	-	-	-	-	-	-	-
-	-	1415333 € 45,00	1415333 € 45,00	1415333 € 45,00	-	1415334 € 45,00	1415334 € 45,00
-	-	-	-	-	-	-	-
-	-	-	-	-	-	-	-
-	-	6712497 € 97,48 z 14/45	6712497 € 97,48 z 14/45	6712497 € 97,48 z 14/45	-	-	-
-	-	-	-	-	-	-	-
4516053 € 72,00	4516499 € 75,00	-	4514611 € 56,00	4514608 € 56,00	4516053 € 72,00	4514607 € 59,40	4515124 € 66,00
-	-	-	-	-	-	-	-
6216890 € 9,87	-	-	-	-	6216890 € 9,87	-	-
-	-	-	-	-	-	-	-
6215027 € 16,64	-	6215018 € 15,60 2000	6215018 € 15,60	6215034 € 18,62	6215027 € 16,64	6215034 € 18,62	6215034 € 18,62
6216891 € 10,24	-	-	-	-	6216891 € 10,24	6216891 € 10,24	6216891 € 10,24
-	-	-	-	-	-	-	-
6215016 € 16,64	-	-	-	-	6215016 € 16,64	6215016 € 16,64	6215016 € 16,64
-	-	-	-	-	-	-	-
-	-	-	-	6212342 € 87,50	-	6212343 € 99,00	6212343 € 99,00
-	-	-	-	6212342 € 87,50	-	6212343 € 99,00	6212343 € 99,00
-	-	4613162 € 246,00	4613162 € 246,00	4613162 € 246,00	-	4614007 € 250,00	4614007 € 250,00
-	-	-	-	-	-	-	-
-	-	-	-	-	-	-	-
-	-	-	-	-	-	-	-
-	-	-	-	-	-	-	-
-	-	-	-	-	-	-	-
-	-	-	-	-	-	-	-

MAXI SCOOTER 125 → 800 4T



MALOSS

Maxi Scooter

125 → 800 4T

with ENGINE **HONDA**

SILVER WING

SILVER WING

S-Wing
ie euro 3S-Wing
ie euro 3

(KF06E)

400 4T

LC

600 4T

LC





125 4T

LC

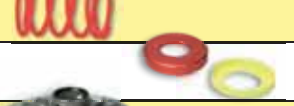

150 4T

LC

Products to be used exclusively for racing in places specially designed for such activity according to the regulations of the competent sporting authorities. We accept no liability resulting from improper use.

	CYLINDER 4 STROKE ALUMINIUM	-	-	3111627 € 328,92 Ø 58	3111588 € 328,92 Ø 61
	CYLINDER I-TECH ALUMINIUM EQUIPPED WITH CDI	-	-	-	-
	POWER CAM CAMSHAFT	-	-	-	-
	HEAD V4 HEAD FOR ORIGINAL CYLINDER / MALOSS	-	-	-	-
	CYLINDER + V4 HEAD ALUMINIUM	-	-	-	-
	CYLINDER + V4 HEAD + POWER CAM ALUMINIUM Ø 75,5	-	-	-	-
	4 STROKE VALVE FOR ENGINE VALVES SET	-	-	-	-
	SPRINGS FOR ENGINE VALVES	-	-	-	-
	CRANKSHAFT RHQ	-	-	-	-
	IGNITION CONTROLLER DIGITRONIC FOR VEHICLES WITHOUT IMMOBILIZER	-	-	-	-
	IGNITION CONTROLLER DIGITRONIC FOR VEHICLES WITH IMMOBILIZER	-	-	-	-
	FORCE MASTER INJECTION CONTROLLER	-	-	5514778 € 240,14	5515226 € 240,14
	TC UNIT O2 controller LAMBDA EMULATOR	-	-	5514750 € 84,00	5514750 € 84,00
	MULTIVAR 2000 VARIATOR MULTIVAR 2000 MHR	5113322 € 159,65	5111812 € 172,79	5111572 € 112,35 5114065 € 122,57	5111572 € 112,35 5114065 € 122,57
	X SPECIAL BELT BELT	6113500 € 120,51	6115803 € 79,60	6114127 € 24,42 6116422 € 48,57	6114127 € 24,42 6116422 € 48,57
	X K BELT BELT				
	HTRoll ROLLERS FOR MULTIVAR 2000 / MHR	6615437.YO € 28,39 gr.18	6615437.B0+.C0 € 28,39 gr.21 +24	6611095.G0+.F0 € 13,64 gr.09,5 +09 MHR	6611095.G0+.H0 € 13,64 gr.09,5 +10 MHR
	HTRoll ROLLERS FOR ORIGINAL VARIATOR	6615437.B0 € 28,39 gr.21	6615437.G0 € 28,39 gr.28	6611534.C0 € 11,00 gr.12,5	6611534.C0 € 11,00 gr.12,5
	VENTILVAR 2000 FIXED HALF-PULLEY	-	-	6112672 € 36,72	6112672 € 36,72
	VARIABLE-SPEED DRIVE ADJUSTER SPRING FOR VARIATOR	PG. 445 2912478.W0*PG* € 11,50	2912478.W0*PG* € 11,50	PG.445	PG.445
	TORSION CONTROLLER ANTIFRICTION FIFTH WHEEL	-	-	-	-
	TORQUE DRIVER MOBILE DRIVEN SPLIT PULLEY	-	-	-	-
	OVER RANGE TRANSMISSION KIT	-	-	-	-
	MAXI FLY CLUTCH NOT ADJUSTABLE CLUTCH	5212823 € 146,14	5212823 € 146,14	5212522 € 70,37	5212522 € 70,37
	MAXI DELTA CLUTCH ADJUSTABLE CLUTCH	-	-	5212487 € 112,59	5212487 € 112,59
	MAXI CLUTCH BELL CLUTCH BELL (SMOOTH RING)	-	-	7714325 € 33,00 Ø 125	7714325 € 33,00 Ø 125
	MAXI WING CLUTCH BELL CLUTCH BELL (FINNED RING)	-	-	7713376 € 38,00 Ø 125	7713376 € 38,00 Ø 125
	MAXI FLY SYSTEM CLUTCH BELL + NOT ADJUSTABLE CLUTCH	-	-	5214724 € 100,47 Ø 125	5214724 € 100,47 Ø 125
	MAXI DELTA SYSTEM CLUTCH BELL + ADJUSTABLE CLUTCH	-	-	5216070 € 125,46 Ø 125	5216070 € 125,46 Ø 125
	SPRINGS FOR MAXI FLY CLUTCH	2913137 € 20,99	2913137 € 20,99	29 9605 € 16,20	29 9605 € 16,20
	SPRINGS FOR MAXI DELTA CLUTCH	-	-	29 9605 € 16,20	29 9605 € 16,20
	SPRINGS FOR ORIGINAL CLUTCH	2912553 € 20,30	2912553 € 20,30	2912536 € 15,56	2912536 € 15,56

PG - SPECIFICATIONS on the PAGE indicated in the TITLE of the LINE

HONDA		ITALJET					
SW-T euro 3	SW-T euro 3	JET SET	JET SET	JUPITER	JUPITER	JUPITER	MILLENNIUM
(NF01E)	(PF01E)	(LEADER)	(LEADER)				
400 4T LC	600 4T LC	125 4T 	150 4T 	125 4T LC	150 4T LC	250 4T LC	125 4T LC
-	-	3111393 € 302,60 Ø 70	3111393 € 302,60 Ø 70	3111248 € 295,09 Ø 63	3111248 € 295,09 Ø 63	31 9578 € 363,37 Ø 74	3111248 € 295,09 Ø 63
-	-	-	-	-	-	-	-
-	-	-	-	5911854 € 162,39	5911854 € 162,39	5911517 € 196,11	5911854 € 162,39
-	-	-	-	-	-	-	-
-	-	-	-	-	-	-	-
-	-	-	-	-	-	2711824 € 77,38	-
-	-	-	-	-	-	-	-
-	-	-	-	-	-	-	-
-	-	-	-	-	-	-	-
-	-	-	-	-	-	-	-
-	-	-	-	-	-	-	-
5113322 € 159,65	5111812 € 172,79	5111397 € 112,35	5111397 € 112,35	5113134 € 112,35	5113134 € 112,35	5111225 € 121,97	5113134 € 112,35
6113500 € 120,51	-	6116117 € 34,27	6116117 € 34,27	6116101 € 42,50	6116101 € 42,50	6116094 € 40,00	6116101 € 42,50
6615437.YO € 28,39 gr.18	6615437.B0+.C0 € 28,39 gr.21 +24	6611095.G0 € 13,64 gr.09,5	6611095.R0 € 13,64 gr.14	6611095.D0+.I0 € 13,64 gr.08 (3) +10,5 (3)	6611095.D0+.I0 € 13,64 gr.08 (3) +10,5 (3)	66 9919.G0 € 22,15 gr.11	6611095.D0+.I0 € 13,64 gr.08 (3) +10,5 (3)
6615437.C0 € 28,39 gr.24	6615437.G0 € 28,39 gr.28	66 9456.F0 € 12,00 gr.08,7	66 9456.H0 € 12,00 gr.10	6611156.C0 € 20,11 gr.09	6611156.E0 € 20,11 gr.10	66 9919.L0 € 22,15 gr.14	6611156.C0 € 20,11 gr.09
-	-	-	-	6111703 € 36,72	6111703 € 36,72	6111102B € 36,72	6111703 € 36,72
2912478.W0*PG* € 11,50	2912478.W0*PG* € 11,50	PG.445	PG.445	2912647.Y0 *PG* € 10,00	2912647.Y0 *PG* € 10,00	PG.445	2912647.Y0 *PG* € 10,00
-	-	2513210 € 5,72	2513210 € 5,72	-	-	-	-
-	-	6111656 € 123,88	6111656 € 123,88	6111660 € 123,88	6111660 € 123,88	6111763 € 159,12	6111660 € 123,88
-	-	-	-	-	-	-	-
5212823 € 146,14	5212823 € 146,14	-	-	-	-	-	-
-	-	5211821 € 120,42	5211821 € 120,42	-	5211888 € 120,42	5211468 € 129,23	-
-	-	-	-	-	7713368 € 59,00 Ø 135	7713368 € 59,00 Ø 135	-
-	-	7715898B € 52,00 Ø 134	7715898B € 52,00 Ø 134	-	-	-	-
-	-	-	-	-	-	-	-
-	-	5216918 € 136,00 Ø 134	5216918 € 136,00 Ø 134	-	-	-	-
2913137 € 20,99	2913137 € 20,99	-	-	-	-	-	-
-	-	2911326 € 17,00	2911326 € 17,00	-	2911326 € 17,00	2911326 € 17,00	-
2912553 € 20,30	2912553 € 20,30	2911326 € 17,00	2911326 € 17,00	2911325 € 17,24	2911326 € 17,00	2911325 € 17,24	2911325 € 17,24



MALOSSİ

Maxi Scooter

125 → 800 4T

with ENGINE **HONDA**











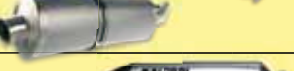





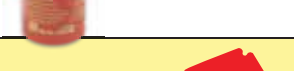















SILVER WING

SILVER WING

S-Wing
ie euro 3S-Wing
ie euro 3

(KF06E)

() CHECK "TYPE" SPECIFICATION (HOMOLOGATION MARK).400 4T **LC** 600 4T **LC** 125 4T **LC** 150 4T **LC**

	CLUTCH DISK SET FOR ORIGINAL CLUTCH		-	-	-	-
	MAXI WILD LION   HOMOLOGATED EXHAUST SYSTEM	PG. 418	-	3212720 € 397,80 *80*	-	-
	RX   HOMOLOGATED EXHAUST SYSTEM	PG. 420	-	-	-	-
	RED CHILLI OIL OIL FILTER		0313827 € 8,00	0313827 € 8,00	-	-
	RED SPONGE FOR ORIGINAL AIR BOX		-	-	-	-
	DOUBLE RED SPONGE FOR ORIGINAL AIR BOX		-	-	-	-
	W BOX FOR ORIGINAL AIR BOX		-	-	-	-
	V FILTER VARIATOR AIR FILTER RIGHT SIDE		-	-	-	-
	POWER TRASMISSION		-	-	-	-
	GEARS HTQ PRIMARY		-	-	6712497 € 97,48 z 14/45	6712570 € 92,77 z 16/44
	GEARS HTQ SECONDARY		-	-	-	-
	SPORT SCREEN SCREEN		-	-	-	-
	MHR SCREEN SCREEN		-	-	-	-
	HOSE KIT FOR BRAKE		-	-	-	-
	BRAKE PADS FRONT ORGANIC BRAKE PADS		*06*	*77*	-	-
	BRAKE PADS MHR FRONT ORGANIC BRAKE PADS		-	-	-	-
	BRAKE PADS MHR SYNT FRONT SINTERED BRAKE PADS		6215032 € 20,00	6215032 € 20,00 2001->	-	-
	BRAKE PADS REAR ORGANIC BRAKE PADS		6216890 € 9,87	6216890 € 9,87 2001->	-	-
	BRAKE PADS MHR REAR ORGANIC BRAKE PADS		-	-	-	-
	BRAKE PADS MHR SYNT REAR SINTERED BRAKE PADS		6215027 € 16,64	6215027 € 16,64 2001->	-	-
	BRAKE POWER REAR BRAKE SHOES		-	-	-	-
	DISC / WHOOP DISC / PAIR WHOOP FRONT BRAKE DISC		6212343 € 99,00	6212343 € 99,00 2001-> 02	6212342 € 87,50	6212342 € 87,50
	DISC / WHOOP DISC REAR BRAKE DISC		6212342 € 87,50	6212342 € 87,50 2001-> 02	-	-
	TWINS MAXI SUSPENSIONS REAR PAIR SHOCK ABSORBER		-	-	-	-
	RS3 - RS1 REAR SHOCK ABSORBER		-	-	-	-
	RS24 REAR SHOCK ABSORBER		-	-	-	-
	RS24 FRONT SHOCK ABSORBER		-	-	-	-
	RS24 FRONT + REAR		-	-	-	-
	F32S FORK STEMS Ø 32		-	-	-	-
	F37R FORK STEMS Ø 37		-	-	-	-

06 - for vehicles PRODUCED 2006-> WITH HANDBRAKE : 6215045 € 7,60

77 - for vehicles PRODUCED 2001-> WITH HANDBRAKE : 6215045 € 7,60

80 - ATTENTION: ONLY FOR euro 0-1-2 vehicles WITHOUT LAMBDA sensor

HONDA		ITALJET													
SW-T euro 3	SW-T euro 3	JET SET	JET SET	JUPITER	JUPITER	JUPITER	MILLENNIUM								
(NF01E)	(PF01E)	(LEADER)	(LEADER)												
400 4T	LC	600 4T	LC	125 4T	⚡	150 4T	⚡	125 4T	LC	150 4T	LC	250 4T	LC	125 4T	LC
-	-	-	-	-	-	-	-	-	-	-	-	-	-	-	-
-	-	-	-	-	-	-	-	-	-	-	-	-	-	-	-
-	-	-	-	-	-	-	-	-	-	-	-	-	-	-	-
0313827	0313827	0313382	0313382	-	-	-	-	-	-	-	-	-	-	-	-
€ 8,00	€ 8,00	€ 7,00	€ 7,00	-	-	-	-	-	-	-	-	1411417	-	-	-
-	-	-	-	-	-	-	-	-	-	-	-	€ 9,06	-	-	-
-	-	-	-	-	-	-	-	-	-	-	-	1414502	-	-	-
-	-	-	-	-	-	-	-	-	-	-	-	€ 7,35	-	-	-
-	-	-	-	-	-	-	-	-	-	-	-	-	-	-	-
-	-	-	-	-	-	-	-	-	-	-	-	-	-	-	-
-	-	-	-	-	-	-	-	-	-	-	-	-	-	-	-
-	-	6712067	6712067	6711238	-	67 9974	6711238	-	-	-	-	-	-	-	-
-	-	€ 69,96 z 15/41	€ 69,96 z 15/41	€ 68,58 z 14/43 <2000	-	€ 90,27 z 17/37	€ 68,58 z 14/43 <2000	-	-	-	-	-	-	-	-
-	-	-	-	-	-	-	-	-	-	-	-	-	-	-	-
-	-	-	-	-	-	-	-	-	-	-	-	-	-	-	-
-	-	-	-	-	-	-	-	-	-	-	-	-	-	-	-
-	-	-	-	-	-	-	-	-	-	-	-	-	-	-	-
6216890	6216890	-	-	-	-	-	-	-	-	-	-	-	-	-	-
€ 9,87	€ 9,87	-	-	-	-	-	-	-	-	-	-	-	-	-	-
-	-	-	-	-	-	-	-	-	-	-	-	-	-	-	-
6215027	6215027	-	-	-	-	-	-	-	-	-	-	-	-	-	-
€ 16,64	€ 16,64	-	-	-	-	-	-	-	-	-	-	-	-	-	-
-	-	-	-	-	-	-	-	-	-	-	-	-	-	-	-
-	-	-	-	-	-	-	-	-	-	-	-	-	-	-	-
6212342	6212342	-	-	-	-	-	-	-	-	-	-	-	-	-	-
€ 87,50	€ 87,50	-	-	-	-	-	-	-	-	-	-	-	-	-	-
-	-	-	-	-	-	-	-	-	-	-	-	-	-	-	-
-	-	-	-	-	-	-	-	-	-	-	-	-	-	-	-
-	-	-	-	-	-	-	-	-	-	-	-	-	-	-	-
-	-	-	-	-	-	-	-	-	-	-	-	-	-	-	-
-	-	-	-	-	-	-	-	-	-	-	-	-	-	-	-
-	-	-	-	-	-	-	-	-	-	-	-	-	-	-	-
-	-	-	-	-	-	-	-	-	-	-	-	-	-	-	-
-	-	-	-	-	-	-	-	-	-	-	-	-	-	-	-

MAXI SCOOTER 125 → 800 4T



MALOSS

Maxi Scooter

125 → 800 4T

with ENGINE 

ITALJET

MILLENNIUM

TORPEDO

TORPEDO

TORPEDO

(LEADER)

(LEADER)

150 4T

LC

125 4T



125 4T



150 4T

	CYLINDER 4 STROKE ALUMINIUM	3111248 € 295,09 Ø 63	31 9518 € 295,92 Ø 60	3111393 € 302,60 Ø 70	3111393 € 302,60 Ø 70
	CYLINDER I-TECH ALUMINIUM EQUIPPED WITH CDI	-	-	-	-
	POWER CAM CAMSHAFT	5911854 € 162,39	-	-	-
	HEAD V4 HEAD FOR ORIGINAL CYLINDER / MALOSS	-	-	-	-
	CYLINDER + V4 HEAD ALUMINIUM	-	-	-	-
	CYLINDER + V4 HEAD + POWER CAM ALUMINIUM Ø 75,5	-	-	-	-
	4 STROKE VALVE FOR ENGINE VALVES SET	-	-	-	-
	SPRINGS FOR ENGINE VALVES	-	-	-	-
	CRANKSHAFT RHQ	-	-	-	-
	IGNITION CONTROLLER DIGITRONIC FOR VEHICLES WITHOUT IMMOBILIZER	-	-	-	-
	IGNITION CONTROLLER DIGITRONIC FOR VEHICLES WITH IMMOBILIZER	-	-	-	-
	FORCE MASTER INJECTION CONTROLLER	-	-	-	-
	TC UNIT O2 controller LAMBDA EMULATOR	-	-	-	-
	MULTIVAR 2000 VARIATOR MULTIVAR 2000 MHR	5113134 € 112,35	5111154 € 75,99	5111397 € 112,35	5111397 € 112,35
	X SPECIAL BELT BELT X K BELT BELT	6116101 € 42,50	-	6116117 € 34,27	6116117 € 34,27
	HTRoll ROLLERS FOR MULTIVAR 2000 / MHR	6611095.D0+.J0 € 13,64 gr.08 (3) +10,5 (3)	66 9420.K0 € 10,00 gr.12	6611095.G0 € 13,64 gr.09,5	6611095.R0 € 13,64 gr.14
	HTRoll ROLLERS FOR ORIGINAL VARIATOR	6611156.E0 € 20,11 gr.10	-	-	-
	VENTILVAR 2000 FIXED HALF-PULLEY	6111703 € 36,72	-	-	-
	VARIABLE-SPEED DRIVE ADJUSTER SPRING FOR VARIATOR	PG. 445 2912647.Y0 *PG* € 10,00	-	PG.445	PG.445
	TORSION CONTROLLER ANTIFRICTION FIFTH WHEEL	-	-	2513210 € 5,72	2513210 € 5,72
	TORQUE DRIVER MOBILE DRIVEN SPLIT PULLEY	6111660 € 123,88	-	6111656 € 123,88	6111656 € 123,88
	OVER RANGE TRANSMISSION KIT	-	-	-	-
	MAXI FLY CLUTCH NOT ADJUSTABLE CLUTCH	-	-	-	-
	MAXI DELTA CLUTCH ADJUSTABLE CLUTCH	5211888 € 120,42	-	5211821 € 120,42	5211821 € 120,42
	MAXI CLUTCH BELL CLUTCH BELL (SMOOTH RING)	7713368 € 59,00 Ø 135	-	-	-
	MAXI WING CLUTCH BELL CLUTCH BELL (FINNED RING)	-	-	7715898B € 52,00 Ø 134	7715898B € 52,00 Ø 134
	MAXI FLY SYSTEM CLUTCH BELL + NOT ADJUSTABLE CLUTCH	-	-	-	-
	MAXI DELTA SYSTEM CLUTCH BELL + ADJUSTABLE CLUTCH	-	-	5216918 € 136,00 Ø 134	5216918 € 136,00 Ø 134
	SPRINGS FOR MAXI FLY CLUTCH	-	-	-	-
	SPRINGS FOR MAXI DELTA CLUTCH	2911326 € 17,00	-	2911326 € 17,00	2911326 € 17,00
	SPRINGS FOR ORIGINAL CLUTCH	2911326 € 17,00	-	2911326 € 17,00	2911326 € 17,00

Products to be used exclusively for racing in places specially designed for such activity according to the regulations of the competent sporting authorities. We accept no liability resulting from improper use.

PG - SPECIFICATIONS on the PAGE indicated in the TITLE of the LINE

KAWASAKI		KEEWAY				KYMCO		
J ie euro 3	LOGIK euro 3	OUTLOOK	OUTLOOK	ZAHARA euro 3	AGILITY euro 3	AGILITY R16 euro 3	AGILITY RS euro 3	
(WS60)	(QJ153MI-2)	(QJ153MI-2)	(QJ158MJ)	(QJ153 QMI-7B)	(KN25)	(KL25B)	(KN25SR)	
300 4T	125 4T	125 4T	150 4T	125 4T	125 4T	125 4T	125 4T	
LC	LC	LC	LC					
-	3111627 € 328,92 Ø 58	3111627 € 328,92 Ø 58	3111588 € 328,92 Ø 61	-	-	-	-	
-	-	-	-	-	-	-	-	
-	5912778 € 164,39	5912778 € 164,39	5912778 € 164,39	-	-	-	-	
-	-	-	-	-	-	-	-	
-	-	-	-	-	-	-	-	
-	-	-	-	-	-	-	-	
-	-	-	-	-	-	-	-	
-	-	-	-	-	-	-	-	
-	-	-	-	-	-	-	-	
-	-	-	-	-	-	-	-	
-	-	-	-	-	-	-	-	
5516341B € 90,00	-	-	-	-	-	-	-	
5114730 € 144,20	5111572 € 112,35 5114065 € 122,57	5111572 € 112,35 5114065 € 122,57	5111572 € 112,35 5114065 € 122,57	5114404 € 112,35	5114404 € 112,35	5114404 € 112,35	5114404 € 112,35	
6115277 € 76,50	6114127 € 24,42 6116422 € 48,57	6114127 € 24,42 6116422 € 48,57	6114127 € 24,42 6116422 € 48,57	-	6113148 € 26,40	6113148 € 26,40	6113148 € 26,40	
66 9917.MO € 19,12 gr.18	6611095.G0+.FO € 13,64 gr.09,5 +09 MHR	6611095.G0+.FO € 13,64 gr.09,5 +09 MHR	6611095.G0+.HO € 13,64 gr.09,5 +10 MHR	6611095.G0 € 13,64 gr.09,5	6611095.G0 € 13,64 gr.09,5	6611095.G0 € 13,64 gr.09,5	6611095.G0 € 13,64 gr.09,5	
66 9919.MO € 22,15 gr.14,5	6611534.B0 € 11,00 gr.11,5	6611534.B0 € 11,00 gr.11,5	-	-	6614705.D0 € 16,50 gr.13	6614705.D0 € 16,50 gr.13	6614705.D0 € 16,50 gr.13	
6114701B € 44,88	6112672 € 36,72	6112672 € 36,72	6112672 € 36,72	-	-	-	-	
2914712.W0*PG* € 14,19	PG.445	PG.445	PG.445	PG.445	PG.445	PG.445	PG.445	
-	-	-	-	-	-	-	-	
-	-	-	-	-	-	-	-	
-	5212522 € 70,37	5212522 € 70,37	5212522 € 70,37	-	5212522 € 70,37 Ø 125	5212522 € 70,37 Ø 125	5212522 € 70,37 Ø 125	
-	5212487 € 112,59	5212487 € 112,59	5212487 € 112,59	-	5212487 € 112,59 Ø 125	5212487 € 112,59 Ø 125	5212487 € 112,59 Ø 125	
-	7714325 € 33,00 Ø 125	7714325 € 33,00 Ø 125	7714325 € 33,00 Ø 125	-	7714325 € 33,00 Ø 125	7714325 € 33,00 Ø 125	7714325 € 33,00 Ø 125	
-	7713376 € 38,00 Ø 125	7713376 € 38,00 Ø 125	7713376 € 38,00 Ø 125	-	-	7713376 € 38,00 Ø 125	7713376 € 38,00 Ø 125	
-	5214724 € 100,47 Ø 125	5214724 € 100,47 Ø 125	5214724 € 100,47 Ø 125	-	5214724 € 100,47 Ø 125	5214724 € 100,47 Ø 125	5214724 € 100,47 Ø 125	
-	5216070 € 125,46 Ø 125	5216070 € 125,46 Ø 125	5216070 € 125,46 Ø 125	-	-	5216070 € 125,46 Ø 125	5216070 € 125,46 Ø 125	
-	29 9605 € 16,20	29 9605 € 16,20	29 9605 € 16,20	-	29 9605 € 16,20	29 9605 € 16,20	29 9605 € 16,20	
-	29 9605 € 16,20	29 9605 € 16,20	29 9605 € 16,20	-	29 9605 € 16,20	29 9605 € 16,20	29 9605 € 16,20	
2915089 € 16,20	2912536 € 15,56	2912536 € 15,56	2912536 € 15,56	2912536 € 15,56	-	-	-	



MALOSSI

Maxi Scooter

125 → 800 4T

with ENGINE 

ITALJET

MILLENNIUM

TORPEDO

TORPEDO

TORPEDO

(LEADER)

(LEADER)

(■) CHECK "TYPE" SPECIFICATION (HOMOLOGATION MARK).

150 4T

LC











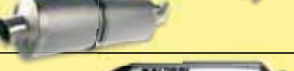



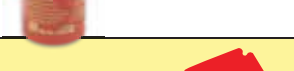















125 4T







125 4T



150 4T

	CLUTCH DISK SET FOR ORIGINAL CLUTCH		-	-	-	-
	MAXI WILD LION (■) HOMOLOGATED EXHAUST SYSTEM		-	-	-	-
	RX (■) HOMOLOGATED EXHAUST SYSTEM		-	-	-	-
	RED CHILLI OIL OIL FILTER		-	0313381 € 3,80	0313382 € 7,00	0313382 € 7,00
	RED SPONGE FOR ORIGINAL AIR BOX		-	-	-	-
	DOUBLE RED SPONGE FOR ORIGINAL AIR BOX		-	-	-	-
	W BOX FOR ORIGINAL AIR BOX		-	-	-	-
	V FILTER VARIATOR AIR FILTER RIGHT SIDE		-	-	-	-
	POWER TRASMISSION		-	-	-	-
	GEARS HTQ PRIMARY		-	-	-	-
	GEARS HTQ SECONDARY		-	-	6712067 € 69,96 z 15/41	6712067 € 69,96 z 15/41
	SPORT SCREEN SCREEN		-	-	-	-
	MHR SCREEN SCREEN		-	-	-	-
	HOSE KIT FOR BRAKE		-	-	-	-
	BRAKE PADS FRONT ORGANIC BRAKE PADS		-	6215051 € 5,72 1999->	-	-
	BRAKE PADS MHR FRONT ORGANIC BRAKE PADS		-	6215076 € 6,24 1999->	-	-
	BRAKE PADS MHR SYNT FRONT SINTERED BRAKE PADS		-	6215005 € 11,96 1999->	-	-
	BRAKE PADS REAR ORGANIC BRAKE PADS		-	-	-	-
	BRAKE PADS MHR REAR ORGANIC BRAKE PADS		-	-	-	-
	BRAKE PADS MHR SYNT REAR SINTERED BRAKE PADS		-	-	-	-
	BRAKE POWER REAR BRAKE SHOES		-	-	-	-
	DISC / WHOOP DISC / PAIR WHOOP FRONT BRAKE DISC		-	-	-	-
	DISC / WHOOP DISC REAR BRAKE DISC		-	-	-	-
	TWINS MAXI SUSPENSIONS REAR PAIR SHOCK ABSORBER		-	-	-	-
	RS3 - RS1 REAR SHOCK ABSORBER		-	-	-	-
	RS24 REAR SHOCK ABSORBER		-	-	-	-
	RS24 FRONT SHOCK ABSORBER		-	-	-	-
	RS24 FRONT + REAR		-	-	-	-
	F32S FORK STEMS Ø 32		-	-	-	-
	F37R FORK STEMS Ø 37		-	-	-	-

KAWASAKI		KEEWAY				KYMCO		
J ie euro 3	LOGIK euro 3	OUTLOOK	OUTLOOK	ZAHARA euro 3	AGILITY euro 3	AGILITY R16 euro 3	AGILITY RS euro 3	
(WS60)	(QJ153MI-2)	(QJ153MI-2)	(QJ158MJ)	(QJ153 QMI-7B)	(KN25)	(KL25B)	(KN255R)	
300 4T LC	125 4T LC	125 4T LC	150 4T LC	125 4T 	125 4T 	125 4T 	125 4T 	
-	-	-	-	-	-	-	-	
-	-	-	-	-	-	-	-	
3214808 € 380,00	-	-	3214796 € 380,00	-	-	-	-	
-	-	-	-	-	-	-	-	
-	-	-	-	-	-	-	-	
-	-	-	-	-	-	-	-	
1415336 € 45,00	-	-	-	-	-	-	-	
-	-	-	-	-	-	-	-	
-	-	-	-	-	-	-	-	
-	-	-	-	-	-	-	-	
4516330B € 61,50	-	-	-	-	-	-	-	
-	-	-	-	-	-	-	-	
6216890 € 9,87	-	6215190 € 8,84	6215190 € 8,84	-	6215055 € 8,84	6215858 € 8,84 2008->	-	
-	-	-	-	-	6215078 € 8,84	-	-	
6215027 € 16,64	-	-	-	-	-	-	-	
-	-	6215190 € 8,84	6215190 € 8,84	-	-	6216060 € 10,92	-	
-	-	-	-	-	-	-	-	
-	-	-	-	-	-	-	-	
-	6212342 € 87,50	6212342 € 87,50	6212342 € 87,50	-	-	-	-	
-	-	6212342 € 87,50	6212342 € 87,50	-	-	-	-	
-	4613162 € 246,00	-	-	-	-	-	-	
-	-	-	-	-	-	-	-	
-	-	-	-	-	-	-	-	
-	-	-	-	-	-	-	-	
-	-	-	-	-	-	-	-	
-	-	-	-	-	-	-	-	
-	-	-	-	-	-	-	-	
-	-	-	-	-	-	-	-	



MALOSI

Maxi Scooter

125 → 800 4T

with ENGINE **KYMCO**AGILITY
euro 3AGILITY R16
euro 3AGILITY R16 i
euro 3

BET & WIN

(KL30)

(KF40-KF40B)

150 4T



150 4T



200 4T

LC

125 4T

LC

	CYLINDER 4 STROKE ALUMINIUM	-	-	-	-
	CYLINDER I-TECH ALUMINIUM EQUIPPED WITH CDI	-	-	-	-
	POWER CAM CAMSHAFT	-	-	-	-
	HEAD V4 HEAD FOR ORIGINAL CYLINDER / MALOSI	-	-	-	-
	CYLINDER + V4 HEAD ALUMINIUM	-	-	-	-
	CYLINDER + V4 HEAD + POWER CAM ALUMINIUM Ø 75,5	-	-	-	-
	4 STROKE VALVE FOR ENGINE VALVES SET	-	-	-	-
	SPRINGS FOR ENGINE VALVES	-	-	-	-
	CRANKSHAFT RHQ	-	-	-	-
	IGNITION CONTROLLER DIGITRONIC FOR VEHICLES WITHOUT IMMOBILIZER	-	-	-	-
	IGNITION CONTROLLER DIGITRONIC FOR VEHICLES WITH IMMOBILIZER	-	-	-	-
	FORCE MASTER INJECTION CONTROLLER	-	-	-	-
	TC UNIT O2 controller LAMBDA EMULATOR	-	-	-	-
	MULTIVAR 2000 VARIATOR	5114404	5114404	5114404	5111260
	MULTIVAR 2000 MHR	€ 112,35	€ 112,35	€ 112,35	€ 112,35
	X SPECIAL BELT BELT	6113148	6113148	6113148	6116215
	X K BELT BELT	€ 26,40	€ 26,40	€ 26,40	€ 31,00
	HTRoll	6611095.MO	6611095.MO	6611095.MO	6611095.GO
	ROLLERS FOR MULTIVAR 2000 / MHR	€ 13,64 gr.11,5	€ 13,64 gr.11,5	€ 13,64 gr.11,5	€ 13,64 gr.09,5
	HTRoll	6614705.DO	6614705.DO	6614705.FO	6611534.HO
	ROLLERS FOR ORIGINAL VARIATOR	€ 16,50 gr.13	€ 16,50 gr.13	€ 16,50 gr.14	€ 11,00 gr.15,5
	VENTILVAR 2000 FIXED HALF-PULLEY	-	-	-	-
	VARIABLE-SPEED DRIVE ADJUSTER SPRING PG. 445 FOR VARIATOR	PG.445	PG.445	PG.445	2911384.YO *PG* € 10,71
	TORSION CONTROLLER ANTIFRICTION FIFTH WHEEL	-	-	-	-
	TORQUE DRIVER MOBILE DRIVEN SPLIT PULLEY	-	-	-	-
	OVER RANGE TRANSMISSION KIT	-	-	-	-
	MAXI FLY CLUTCH NOT ADJUSTABLE CLUTCH	5212522 € 70,37 Ø 125	5212522 € 70,37 Ø 125	5212522 € 70,37 Ø 125	-
	MAXI DELTA CLUTCH ADJUSTABLE CLUTCH	5212487 € 112,59 Ø 125	5212487 € 112,59 Ø 125	5212487 € 112,59 Ø 125	-
	MAXI CLUTCH BELL CLUTCH BELL (SMOOTH RING)	7714325 € 33,00 Ø 125	7714325 € 33,00 Ø 125	7714325 € 33,00 Ø 125	-
	MAXI WING CLUTCH BELL CLUTCH BELL (FINNED RING)	-	-	-	-
	MAXI FLY SYSTEM CLUTCH BELL + NOT ADJUSTABLE CLUTCH	5214724 € 100,47 Ø 125	5214724 € 100,47 Ø 125	5214724 € 100,47 Ø 125	-
	MAXI DELTA SYSTEM CLUTCH BELL + ADJUSTABLE CLUTCH	-	-	-	-
	SPRINGS FOR MAXI FLY CLUTCH	29 9605 € 16,20	29 9605 € 16,20	29 9605 € 16,20	-
	SPRINGS FOR MAXI DELTA CLUTCH	29 9605 € 16,20	29 9605 € 16,20	29 9605 € 16,20	-
	SPRINGS FOR ORIGINAL CLUTCH	-	-	2912536 € 15,56	2911326 € 17,00

Products to be used exclusively for racing in places specially designed for such activity according to the regulations of the competent sporting authorities. We accept no liability resulting from improper use.

PG - SPECIFICATIONS on the PAGE indicated in the TITLE of the LINE

KYMCO

BET & WIN		BET & WIN		DINK euro 0-1-2		GRAND DINK euro 0-1-2		DINK euro 0-1-2		GRAND DINK euro 0-1-2		DINK		DINK DD ie	
													(SH 40 A)		(SJ 40)
150 4T	LC	250 4T	LC	125 4T	LC	125 4T	LC	150 4T	LC	150 4T	LC	200 4T	LC	200 4T	LC
-		-		-		-		-		-		-		-	
-		-		-		-		-		-		-		-	
-		-		-		-		-		-		-		-	
-		-		-		-		-		-		-		-	
-		-		-		-		-		-		-		-	
-		-		-		-		-		-		-		-	
-		-		-		-		-		-		-		-	
-		-		-		-		-		-		-		-	
-		-		-		-		-		-		-		-	
-		-		-		-		-		-		-		-	
-		-		-		-		-		-		-		-	
-		-		-		-		-		-		-		-	
-		-		-		-		-		-		-		-	
5111260 € 112,35		5111838 € 127,65		5111260 € 112,35		5111260 € 112,35		5111260 € 112,35		5111260 € 112,35		5111260 € 112,35		5111260 € 112,35	
6116215 € 31,00		6116568 € 43,86		6116215 € 31,00		6116215 € 31,00		6116215 € 31,00		6116215 € 31,00		6116215 € 31,00		6116215 € 31,00	
6611095.G0 € 13,64 gr.09,5		66 9917.Q0 € 19,12 gr.20		6611095.G0 € 13,64 gr.09,5		6611095.G0 € 13,64 gr.09,5		6611095.G0 € 13,64 gr.09,5		6611095.G0 € 13,64 gr.09,5		6611095.Q0 € 13,64 gr.13,5		6611095.Q0 € 13,64 gr.13,5	
6611534.H0 € 11,00 gr.15,5		66 9917.Q0 € 19,12 gr.20		6611534.H0 € 11,00 gr.15,5		6611534.C0 € 11,00 gr.12,5		6611534.H0 € 11,00 gr.15,5		6611534.H0 € 11,00 gr.15,5		-		-	
-		-		-		-		-		-		-		-	
2911384.Y0 *PG* € 10,71		2911074.Y0 *PG* € 10,71		2911384.Y0 *PG* € 10,71		2911384.Y0 *PG* € 10,71		2911384.Y0 *PG* € 10,71		2911384.Y0 *PG* € 10,71		-		-	
-		-		-		-		-		-		-		-	
-		-		-		-		-		-		-		-	
-		-		-		-		-		-		-		-	
-		-		-		-		-		-		-		-	
-		-		-		-		-		-		-		-	
-		-		-		-		-		-		-		-	
-		-		-		-		-		-		-		-	
-		-		-		-		-		-		-		-	
-		-		-		-		-		-		-		-	
-		-		-		-		-		-		-		-	
-		-		-		-		-		-		-		-	
-		-		-		-		-		-		-		-	
-		-		-		-		-		-		-		-	
2911326 € 17,00		-		2911326 € 17,00		2911326 € 17,00		2911326 € 17,00		2911326 € 17,00		-		-	

MAXI SCOOTER 125 → 800 4T



MALOSS

Maxi Scooter

125 → 800 4T

with ENGINE **KYMCO**AGILITY
euro 3AGILITY R16
euro 3AGILITY R16 i
euro 3

BET & WIN

(KL30)

(KF40-KF40B)

() CHECK "TYPE" SPECIFICATION (HOMOLOGATION MARK).

150 4T



150 4T



































200 4T

LC

125 4T

LC

	CLUTCH DISK SET FOR ORIGINAL CLUTCH		-	-	-	-
	MAXI WILD LION  HOMOLOGATED EXHAUST SYSTEM		-	-	-	-
	RX  HOMOLOGATED EXHAUST SYSTEM		-	-	-	-
	RED CHILLI OIL OIL FILTER		-	-	-	-
	RED SPONGE FOR ORIGINAL AIR BOX		-	-	-	-
	DOUBLE RED SPONGE FOR ORIGINAL AIR BOX		-	-	-	-
	W BOX FOR ORIGINAL AIR BOX		-	-	-	-
	V FILTER VARIATOR AIR FILTER RIGHT SIDE		-	-	-	-
	POWER TRASMISSION		-	-	-	-
	GEARS HTQ PRIMARY		-	-	-	-
	GEARS HTQ SECONDARY		-	-	-	-
	SPORT SCREEN SCREEN		-	-	-	-
	MHR SCREEN SCREEN		-	-	-	-
	HOSE KIT FOR BRAKE		-	-	-	-
	BRAKE PADS FRONT ORGANIC BRAKE PADS		6215055 € 8,84	6215858 € 8,84 2008->09	6215858 € 8,84 2010->	6215055 € 8,84 2000->
	BRAKE PADS MHR FRONT ORGANIC BRAKE PADS		6215078 € 8,84	-	-	6215078 € 8,84 2000->
	BRAKE PADS MHR SYNT FRONT SINTERED BRAKE PADS		-	-	-	-
	BRAKE PADS REAR ORGANIC BRAKE PADS		-	6215055 € 8,84	6215055 € 8,84	6215055 € 8,84 2000->
	BRAKE PADS MHR REAR ORGANIC BRAKE PADS		-	6215078 € 8,84	-	6215078 € 8,84 2000->
	BRAKE PADS MHR SYNT REAR SINTERED BRAKE PADS		-	-	-	-
	BRAKE POWER REAR BRAKE SHOES		-	-	-	-
	DISC / WHOOP DISC / PAIR WHOOP FRONT BRAKE DISC		-	-	-	-
	DISC / WHOOP DISC REAR BRAKE DISC		-	-	-	-
	TWINS MAXI SUSPENSIONS REAR PAIR SHOCK ABSORBER		-	-	-	-
	RS3 - RS1 REAR SHOCK ABSORBER		-	-	-	-
	RS24 REAR SHOCK ABSORBER		-	-	-	-
	RS24 FRONT SHOCK ABSORBER		-	-	-	-
	RS24 FRONT + REAR		-	-	-	-
	F32S FORK STEMS Ø 32		-	-	-	-
	F37R FORK STEMS Ø 37		-	-	-	-

KYMCO

BET & WIN		BET & WIN		DINK euro 0-1-2		GRAND DINK euro 0-1-2		DINK euro 0-1-2		GRAND DINK euro 0-1-2		DINK		DINK DD ie	
												(SH 40 A)		(SJ 40)	
150 4T	LC	250 4T	LC	125 4T	LC	125 4T	LC	150 4T	LC	150 4T	LC	200 4T	LC	200 4T	LC
-		-		-		-		-		-		-		-	
-		-		-		-		-		-		-		-	
-		-		-		-		-		-		-		-	
-		-		-		-		-		-		-		-	
-		-		-		-		-		-		-		-	
-		-		-		-		-		-		-		-	
-		-		-		-		-		-		-		-	
-		-		-		-		-		-		-		-	
-		-		-		-		-		-		-		-	
-		-		-		-		-		-		-		-	
-		-		-		-		-		-		-		-	
-		-		-		-		-		-		-		-	
-		-		-		-		-		-		-		-	
-		-		-		-		-		-		-		-	
-		-		-		-		-		-		-		-	
-		-		-		-		-		-		-		-	
-		-		-		-		-		-		-		-	
-		-		-		-		-		-		-		-	
-		-		-		-		-		-		-		-	
-		-		-		-		-		-		-		-	
6215055 € 8,84 2000->		6215055 € 8,84 2000->		-		-		-		-		6215055 € 8,84		6215055 € 8,84	
6215078 € 8,84 2000->		6215078 € 8,84 2000->		-		-		-		-		6215078 € 8,84		6215078 € 8,84	
-		-		-		-		-		-		-		-	
-		-		-		-		-		-		-		-	
-		-		-		-		-		-		-		-	
6215055 € 8,84 2000->		6215055 € 8,84 2000->		-		-		-		-		6215055 € 8,84		6215055 € 8,84	
6215078 € 8,84 2000->		6215078 € 8,84 2000->		-		-		-		-		6215078 € 8,84		6215078 € 8,84	
-		-		-		-		-		-		-		-	
-		-		-		-		-		-		-		-	
-		-		-		-		-		-		-		-	
-		-		-		-		-		-		-		-	
-		-		4613460 € 248,00		4613460 € 248,00		4613460 € 248,00		4613460 € 248,00		4613460 € 248,00		4613460 € 248,00	
-		-		-		-		-		-		-		-	
-		-		-		-		-		-		-		-	
-		-		-		-		-		-		-		-	
-		-		-		-		-		-		-		-	
-		-		-		-		-		-		-		-	
-		-		-		-		-		-		-		-	
-		-		-		-		-		-		-		-	

MAXI SCOOTER 125 → 800 4T





MALOSS

Maxi Scooter

125 → 800 4T

with ENGINE **KYMCO**DINK Street
ie euro 3DINK Street
ie euro 3DINK Street
ie euro 3DINK Street
ie euro 3
2012->

(SK25)

(SK40)

(SK60)

(SK60A)

125 4T

LC

200 4T

LC

300 4T

LC

300 4T

LC

Products to be used exclusively for racing in places specially designed for such activity according to the regulations of the competent sporting authorities. We accept no liability resulting from improper use.

	CYLINDER 4 STROKE ALUMINIUM	-	-	-	-
	CYLINDER I-TECH ALUMINIUM EQUIPPED WITH CDI	-	-	-	-
	POWER CAM CAMSHAFT	-	-	-	-
	HEAD V4 HEAD FOR ORIGINAL CYLINDER / MALOSS	-	-	-	-
	CYLINDER + V4 HEAD ALUMINIUM	-	-	-	-
	CYLINDER + V4 HEAD + POWER CAM ALUMINIUM Ø 75,5	-	-	-	-
	4 STROKE VALVE FOR ENGINE VALVES SET	-	-	-	-
	SPRINGS FOR ENGINE VALVES	-	-	-	-
	CRANKSHAFT RHQ	-	-	-	-
	IGNITION CONTROLLER DIGITRONIC FOR VEHICLES WITHOUT IMMOBILIZER	-	-	-	-
	IGNITION CONTROLLER DIGITRONIC FOR VEHICLES WITH IMMOBILIZER	-	-	-	-
	FORCE MASTER INJECTION CONTROLLER	-	-	-	-
	TC UNIT O2 controller LAMBDA EMULATOR	-	-	5516341B € 90,00	5516341B € 90,00
	MULTIVAR 2000 VARIATOR	5114266	5114238	5114238	5114730
	MULTIVAR 2000 MHR	€ 112,35	€ 144,20	€ 144,20	€ 144,20
	X SPECIAL BELT BELT	6115275	6115276	6115277	6115277
	X K BELT BELT	€ 35,70	€ 63,24	€ 76,50	€ 76,50
	HTRoll	6611095.I0	66 9917.M0	66 9917.Q0	66 9917.M0
	ROLLERS FOR MULTIVAR 2000 / MHR	€ 13,64	€ 19,12 gr.18	€ 19,12 gr.20	€ 19,12 gr.18
	HTRoll	-	66 9919.H0	66 9919.L0	66 9919.M0
	ROLLERS FOR ORIGINAL VARIATOR	-	€ 22,15 gr.12	€ 22,15 gr.14	€ 22,15 gr.14,5
	VENTILVAR 2000 FIXED HALF-PULLEY	-	-	6114701B € 44,88	6114701B € 44,88
	VARIABLE-SPEED DRIVE ADJUSTER SPRING PG. 445 FOR VARIATOR	PG.445	PG.445	PG.445	2914712.W0 *PG* € 14,19
	TORSION CONTROLLER ANTIFRICTION FIFTH WHEEL	-	-	-	-
	TORQUE DRIVER MOBILE DRIVEN SPLIT PULLEY	-	-	-	-
	OVER RANGE TRANSMISSION KIT	-	-	-	-
	MAXI FLY CLUTCH NOT ADJUSTABLE CLUTCH	-	-	-	-
	MAXI DELTA CLUTCH ADJUSTABLE CLUTCH	-	-	-	-
	MAXI CLUTCH BELL CLUTCH BELL (SMOOTH RING)	-	-	-	-
	MAXI WING CLUTCH BELL CLUTCH BELL (FINNED RING)	-	-	-	-
	MAXI FLY SYSTEM CLUTCH BELL + NOT ADJUSTABLE CLUTCH	-	-	-	-
	MAXI DELTA SYSTEM CLUTCH BELL + ADJUSTABLE CLUTCH	-	-	-	-
	SPRINGS FOR MAXI FLY CLUTCH	-	-	-	-
	SPRINGS FOR MAXI DELTA CLUTCH	-	-	-	-
	SPRINGS FOR ORIGINAL CLUTCH	2912779 € 21,00	2915089 € 16,20	2915089 € 16,20	2915089 € 16,20

PG - SPECIFICATIONS on the PAGE indicated in the TITLE of the LINE



MALOSSI

Maxi Scooter

125 → 800 4T

with ENGINE **KYMCO**DINK Street
ie euro 3DINK Street
ie euro 3DINK Street
ie euro 3DINK Street
ie euro 3
2012->











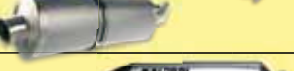





















(SK25)

(SK40)

(SK60)

(SK60A)

() CHECK "TYPE" SPECIFICATION (HOMOLOGATION MARK).125 4T **LC** 200 4T **LC** 300 4T **LC** 300 4T **LC**

	CLUTCH DISK SET FOR ORIGINAL CLUTCH		-	-	-	-
	MAXI WILD LION   HOMOLOGATED EXHAUST SYSTEM		-	-	-	-
	RX   HOMOLOGATED EXHAUST SYSTEM		-	-	3214808 € 380,00	3214808 € 380,00
	RED CHILLI OIL OIL FILTER		-	-	-	-
	RED SPONGE FOR ORIGINAL AIR BOX		-	-	-	-
	DOUBLE RED SPONGE FOR ORIGINAL AIR BOX		-	-	-	-
	W BOX FOR ORIGINAL AIR BOX		1415336 € 45,00	1415336 € 45,00	1415336 € 45,00	1415336 € 45,00
	V FILTER VARIATOR AIR FILTER RIGHT SIDE		-	-	-	-
	POWER TRASMISSION		-	-	-	-
	GEARS HTQ PRIMARY		-	-	-	-
	GEARS HTQ SECONDARY		-	-	-	-
	SPORT SCREEN SCREEN		4515116 € 62,76	4515116 € 62,76	4515116 € 62,76	4515116 € 62,76
	MHR SCREEN SCREEN		-	-	-	-
	HOSE KIT FOR BRAKE		-	-	-	-
	BRAKE PADS FRONT ORGANIC BRAKE PADS		6216890 € 9,87	6216890 € 9,87	6216890 € 9,87	6216890 € 9,87
	BRAKE PADS MHR FRONT ORGANIC BRAKE PADS		-	-	-	-
	BRAKE PADS MHR SYNT FRONT SINTERED BRAKE PADS		6215027 € 16,64	6215027 € 16,64	6215027 € 16,64	6215027 € 16,64
	BRAKE PADS REAR ORGANIC BRAKE PADS		-	-	-	-
	BRAKE PADS MHR REAR ORGANIC BRAKE PADS		-	-	-	-
	BRAKE PADS MHR SYNT REAR SINTERED BRAKE PADS		-	-	-	-
	BRAKE POWER REAR BRAKE SHOES		-	-	-	-
	DISC / WHOOP DISC / PAIR WHOOP FRONT BRAKE DISC		-	-	-	-
	DISC / WHOOP DISC REAR BRAKE DISC		-	-	-	-
	TWINS MAXI SUSPENSIONS REAR PAIR SHOCK ABSORBER		-	-	-	-
	RS3 - RS1 REAR SHOCK ABSORBER		-	-	-	-
	RS24 REAR SHOCK ABSORBER		-	-	-	-
	RS24 FRONT SHOCK ABSORBER		-	-	-	-
	RS24 FRONT + REAR		-	-	-	-
	F32S FORK STEMS Ø 32		-	-	-	-
	F37R FORK STEMS Ø 37		-	-	-	-

KYMCO

DOWNTOWN ie euro 3		DOWNTOWN ie euro 3		DOWNTOWN ie euro 3		DOWNTOWN ie euro 3 2012->		G6E ie euro 3		G6E ie euro 3		G-DINK ie euro 3		G-DINK ie euro 3	
(SK25)		(SK40)		(SK60)		(SK60A)		(SR25F)		(SR30F)		(SP25)		(SH60)	
125 4T	LC	200 4T	LC	300 4T	LC	300 4T	LC	125 4T	LC	150 4T	LC	125 4T	LC	300 4T	LC
-		-		-		-		-		-		-		-	
-		-		-		-		-		-		-		-	
-		-		3214808 € 380,00		3214808 € 380,00		-		-		-		-	
-		-		-		-		-		-		-		-	
-		-		-		-		-		-		-		-	
-		-		-		-		-		-		-		-	
1415336 € 45,00		1415336 € 45,00		1415336 € 45,00		1415336 € 45,00		-		-		-		-	
-		-		-		-		-		-		-		-	
-		-		-		-		-		-		-		-	
-		-		-		-		-		-		-		-	
-		-		-		-		-		-		-		-	
4515116 € 62,76		4515116 € 62,76		4515116 € 62,76		4515116 € 62,76		-		-		-		-	
-		-		-		-		-		-		-		-	
6216890 € 9,87		6216890 € 9,87		6216890 € 9,87		6216890 € 9,87		-		-		6216890 € 9,87		6216890 € 9,87	
-		-		-		-		-		-		-		-	
6215027 € 16,64		6215027 € 16,64		6215027 € 16,64		6215027 € 16,64		-		-		6215027 € 16,64		6215027 € 16,64	
6216957 € 9,50		6216957 € 9,50		6216957 € 9,50		6216957 € 9,50		-		-		6216899 € 9,50		6216899 € 9,50	
-		-		-		-		-		-		-		-	
-		-		-		-		-		-		6215028 € 20,00		6215028 € 20,00	
-		-		-		-		-		-		-		-	
-		-		-		-		-		-		-		-	
-		-		-		-		-		-		-		-	
-		-		-		-		-		-		-		-	
-		-		-		-		-		-		-		-	
-		-		-		-		-		-		-		-	
-		-		-		-		-		-		-		-	
-		-		-		-		-		-		-		-	
-		-		-		-		-		-		-		-	
-		-		-		-		-		-		-		-	
-		-		-		-		-		-		-		-	
-		-		-		-		-		-		-		-	
-		-		-		-		-		-		-		-	



MALOSS

Maxi Scooter

125 → 800 4T

with ENGINE 

KYMCO

GRAND DINK

K-XCT
ie euro 3K-XCT
ie euro 3LIKE
euro 3

(SK60B)

(KA40)

250 4T

LC

125 4T



LC

300 4T

LC

125 4T



	CYLINDER 4 STROKE ALUMINIUM	-	-	-	-
	CYLINDER I-TECH ALUMINIUM EQUIPPED WITH CDI	-	-	-	-
	POWER CAM CAMSHAFT	-	-	-	-
	HEAD V4 HEAD FOR ORIGINAL CYLINDER / MALOSS	-	-	-	-
	CYLINDER + V4 HEAD ALUMINIUM	-	-	-	-
	CYLINDER + V4 HEAD + POWER CAM ALUMINIUM Ø 75,5	-	-	-	-
	4 STROKE VALVE FOR ENGINE VALVES SET	-	-	-	-
	SPRINGS FOR ENGINE VALVES	-	-	-	-
	CRANKSHAFT RHQ	-	-	-	-
	IGNITION CONTROLLER DIGITRONIC FOR VEHICLES WITHOUT IMMOBILIZER	-	-	-	-
	IGNITION CONTROLLER DIGITRONIC FOR VEHICLES WITH IMMOBILIZER	-	-	-	-
	FORCE MASTER INJECTION CONTROLLER	-	-	-	-
	TC UNIT O2 controller LAMBDA EMULATOR	-	-	5516341B € 90,00	-
	MULTIVAR 2000 VARIATOR	5111838 € 127,65	5114266 € 112,35	5114730 € 144,20	5114404 € 112,35
	MULTIVAR 2000 MHR	6116568 € 43,86	6115275 € 35,70	6115277 € 76,50	6113148 € 26,40
	X SPECIAL BELT BELT				
	X K BELT BELT				
	HTRoll	66 9917.Q0 € 19,12 gr.20	6611095.I0 € 13,64	66 9917.M0 € 19,12 gr.18	6611095.G0 € 13,64 gr.09,5
	ROLLERS FOR MULTIVAR 2000 / MHR				
	HTRoll	66 9917.Q0 € 19,12 gr.20	-	66 9919.M0 € 22,15 gr.14,5	6614705.F0 € 16,50 gr.14
	ROLLERS FOR ORIGINAL VARIATOR				
	VENTILVAR 2000 FIXED HALF-PULLEY	-	-	6114701B € 44,88	-
	VARIABLE-SPEED DRIVE ADJUSTER SPRING FOR VARIATOR	PG. 445 2911074.Y0 *PG* € 10,71	PG.445	2914712.W0 *PG* € 14,19	PG.445
	TORSION CONTROLLER ANTIFRICTION FIFTH WHEEL	-	-	-	-
	TORQUE DRIVER MOBILE DRIVEN SPLIT PULLEY	-	-	-	-
	OVER RANGE TRANSMISSION KIT	-	-	-	-
	MAXI FLY CLUTCH NOT ADJUSTABLE CLUTCH	-	-	-	5212522 € 70,37 Ø 125
	MAXI DELTA CLUTCH ADJUSTABLE CLUTCH	-	-	-	5212487 € 112,59 Ø 125
	MAXI CLUTCH BELL CLUTCH BELL (SMOOTH RING)	-	-	-	7714325 € 33,00 Ø 125
	MAXI WING CLUTCH BELL CLUTCH BELL (FINNED RING)	7715900B € 59,00 Ø 153	-	-	-
	MAXI FLY SYSTEM CLUTCH BELL + NOT ADJUSTABLE CLUTCH	-	-	-	5214724 € 100,47 Ø 125
	MAXI DELTA SYSTEM CLUTCH BELL + ADJUSTABLE CLUTCH	-	-	-	-
	SPRINGS FOR MAXI FLY CLUTCH	-	-	-	29 9605 € 16,20
	SPRINGS FOR MAXI DELTA CLUTCH	-	-	-	29 9605 € 16,20
	SPRINGS FOR ORIGINAL CLUTCH	-	2912779 € 21,00	2915089 € 16,20	2912536 € 15,56

Products to be used exclusively for racing in places specially designed for such activity according to the regulations of the competent sporting authorities. We accept no liability resulting from improper use.

PG - SPECIFICATIONS on the PAGE indicated in the TITLE of the LINE

KYMCO

LIKE ie euro 3		MOVIE euro 3		MYROAD i		NIKITA ie euro 3		NIKITA ie euro 3		PEOPLE - PEOPLE S euro 3		PEOPLE GTi ie euro 3		PEOPLE One ie euro 3	
(KA40)				(SAAD)								(BF25)		(KM25)	
200 4T	🔊	125 4T	🔊	700 4T	LC	200 4T	LC	300 4T	LC	125 4T	🔊	125 4T	LC	125 4T	🔊
-		-		-		-		-		-		-		-	
-		-		-		-		-		-		-		-	
-		-		-		-		-		-		-		-	
-		-		-		-		-		-		-		-	
-		-		-		-		-		-		-		-	
-		-		-		-		-		-		-		-	
-		-		-		-		-		-		-		-	
-		-		-		-		-		-		-		-	
-		-		-		-		-		-		-		-	
-		-		-		-		-		-		-		-	
-		-		-		-		-		-		-		-	
-		-		-		-		-		-		-		-	
5114404 € 112,35		5114404 € 112,35		-		5114238 € 144,20		5114730 € 144,20		5114404 € 112,35		5114266 € 112,35		5114404 € 112,35	
6113148 € 26,40		-		-		6115276 € 63,24		6115277 € 76,50		6113148 € 26,40		6115275 € 35,70		6113148 € 26,40	
6611095.MO € 13,64 gr.11,5		6611095.GO € 13,64 gr.09,5		-		66 9917.MO € 19,12 gr.18		66 9917.MO € 19,12 gr.18		6611095.GO € 13,64 gr.09,5		6611095.IO € 13,64		6611095.GO € 13,64 gr.09,5	
6614705.FO € 16,50 gr.14		6614705.DO € 16,50 gr.13		-		66 9919.HO € 22,15 gr.12		66 9919.MO € 22,15 gr.14,5		6614705.DO € 16,50 gr.13		-		6614705.FO € 16,50 gr.14	
-		-		-		-		6114701B € 44,88		-		-		-	
PG.445		PG.445		-		PG.445		2914712.WO*PG* € 14,19		PG.445		PG.445		PG.445	
-		-		-		-		-		-		-		-	
-		-		-		-		-		-		-		-	
-		-		-		-		-		-		-		-	
5212522 € 70,37 Ø 125		5212522 € 70,37 Ø 125		-		-		-		5212522 € 70,37 Ø 125		-		5212522 € 70,37 Ø 125	
5212487 € 112,59 Ø 125		5212487 € 112,59 Ø 125		-		-		-		5212487 € 112,59 Ø 125		-		5212487 € 112,59 Ø 125	
7714325 € 33,00 Ø 125		7714325 € 33,00 Ø 125		-		-		-		7714325 € 33,00 Ø 125		-		7714325 € 33,00 Ø 125	
-		-		-		-		-		-		-		-	
5214724 € 100,47 Ø 125		5214724 € 100,47 Ø 125		-		-		-		5214724 € 100,47 Ø 125		-		5214724 € 100,47 Ø 125	
-		-		-		-		-		-		-		-	
29 9605 € 16,20		29 9605 € 16,20		-		-		-		29 9605 € 16,20		-		29 9605 € 16,20	
29 9605 € 16,20		29 9605 € 16,20		-		-		-		29 9605 € 16,20		-		29 9605 € 16,20	
2912536 € 15,56		-		2913137 € 20,99		2915089 € 16,20		2915089 € 16,20		2912536 € 15,56		2912779 € 21,00		2912536 € 15,56	



MALOSSI

Maxi Scooter

125 → 800 4T

with ENGINE **KYMCO**

GRAND DINK

K-XCT
ie euro 3K-XCT
ie euro 3LIKE
euro 3

(SK60B)

(KA40)

() CHECK "TYPE" SPECIFICATION (HOMOLOGATION MARK).

250 4T

LC

125 4T











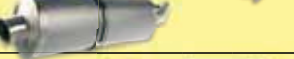









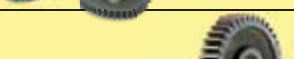



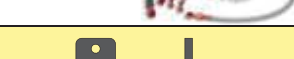

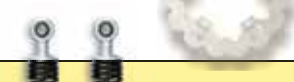

LC

300 4T

LC

125 4T



	CLUTCH DISK SET FOR ORIGINAL CLUTCH		-	-	-	-
	MAXI WILD LION   HOMOLOGATED EXHAUST SYSTEM		-	-	-	-
	RX   HOMOLOGATED EXHAUST SYSTEM		-	-	3216641 € 380,00	-
	RED CHILLI OIL OIL FILTER		-	-	-	-
	RED SPONGE FOR ORIGINAL AIR BOX		-	-	-	-
	DOUBLE RED SPONGE FOR ORIGINAL AIR BOX		-	-	-	-
	W BOX FOR ORIGINAL AIR BOX		-	-	-	-
	V FILTER VARIATOR AIR FILTER RIGHT SIDE		-	-	-	-
	POWER TRASMISSION		-	-	-	-
	GEARS HTQ PRIMARY		-	-	-	-
	GEARS HTQ SECONDARY		-	-	-	-
	SPORT SCREEN SCREEN		-	-	4516052 € 70,80	-
	MHR SCREEN SCREEN		-	-	-	-
	HOSE KIT FOR BRAKE		-	-	-	-
	BRAKE PADS FRONT ORGANIC BRAKE PADS		-	-	-	-
	BRAKE PADS MHR FRONT ORGANIC BRAKE PADS		-	-	-	-
	BRAKE PADS MHR SYNT FRONT SINTERED BRAKE PADS		-	-	-	-
	BRAKE PADS REAR ORGANIC BRAKE PADS		-	-	6216899 € 9,50	6215055 € 8,84
	BRAKE PADS MHR REAR ORGANIC BRAKE PADS		-	-	-	6215078 € 8,84
	BRAKE PADS MHR SYNT REAR SINTERED BRAKE PADS		-	-	6215028 € 20,00	-
	BRAKE POWER REAR BRAKE SHOES		-	-	-	-
	DISC / WHOOP DISC / PAIR WHOOP FRONT BRAKE DISC		-	-	-	-
	DISC / WHOOP DISC REAR BRAKE DISC		-	-	-	-
	TWINS MAXI SUSPENSIONS REAR PAIR SHOCK ABSORBER		-	-	-	-
	RS3 - RS1 REAR SHOCK ABSORBER		-	-	-	-
	RS24 REAR SHOCK ABSORBER		-	-	-	-
	RS24 FRONT SHOCK ABSORBER		-	-	-	-
	RS24 FRONT + REAR		-	-	-	-
	F32S FORK STEMS Ø 32		-	-	-	-
	F37R FORK STEMS Ø 37		-	-	-	-

KYMCO

LIKE ie euro 3	MOVIE euro 3	MYROAD i	NIKITA ie euro 3	NIKITA ie euro 3	PEOPLE - PEOPLE S euro 3	PEOPLE GTi ie euro 3	PEOPLE One ie euro 3
(KA40)	(KM25)	(SAAD)				(BF25)	(KM25)
200 4T	125 4T	700 4T	200 4T	300 4T	125 4T	125 4T	125 4T
		LC	LC	LC		LC	
-	-	-	-	-	-	-	-
-	-	-	-	-	-	-	-
-	-	-	-	3214808 € 380,00	-	-	-
-	-	-	-	-	-	-	-
-	-	-	-	-	-	-	-
-	-	-	-	-	-	-	-
-	-	-	1415336 € 45,00	1415336 € 45,00	-	-	-
-	-	-	-	-	-	-	-
-	-	-	-	-	-	-	-
-	-	-	-	-	-	-	-
-	-	-	4515116 € 62,76	4515116 € 62,76	-	-	-
-	-	-	-	-	-	-	-
-	-	6216890 € 9,87	6216890 € 9,87	6216890 € 9,87	6215858 € 8,84 2007->08	6216938 € 9,87	-
-	-	-	-	-	-	-	-
-	-	6215027 € 16,64	6215027 € 16,64	6215027 € 16,64	-	6215037 € 20,00	-
6215055 € 8,84	-	-	-	-	6216899 € 9,50	-	-
6215078 € 8,84	-	-	-	-	-	-	-
-	-	-	-	-	6215028 € 20,00	-	-
-	-	-	-	-	-	-	-
-	-	-	-	-	-	-	-
-	-	-	-	-	-	-	-
-	-	-	-	-	-	-	-
-	-	-	-	-	-	-	-
-	-	-	-	-	-	-	-
-	-	-	-	-	-	-	-
-	-	-	-	-	-	-	-
-	-	-	-	-	-	-	-
-	-	-	-	-	-	-	-
-	-	-	-	-	-	-	-
-	-	-	-	-	-	-	-
-	-	-	-	-	-	-	-



MALOSS

Maxi Scooter

125 → 800 4T

with ENGINE **KYMCO**

PEOPLE

PEOPLE GTI
ie euro 3

PEOPLE S

PEOPLE -
PEOPLE S
euro 2

(BF40)

(BA 40)

150 4T



200 4T

LC

200 4T



250 4T

LC

Products to be used exclusively for racing in places specially designed for such activity according to the regulations of the competent sporting authorities. We accept no liability resulting from improper use.

	CYLINDER 4 STROKE ALUMINIUM	-	-	-	-
	CYLINDER I-TECH ALUMINIUM EQUIPPED WITH CDI	-	-	-	-
	POWER CAM CAMSHAFT	-	-	-	-
	HEAD V4 HEAD FOR ORIGINAL CYLINDER / MALOSS	-	-	-	-
	CYLINDER + V4 HEAD ALUMINIUM	-	-	-	-
	CYLINDER + V4 HEAD + POWER CAM ALUMINIUM Ø 75,5	-	-	-	-
	4 STROKE VALVE FOR ENGINE VALVES SET	-	-	-	-
	SPRINGS FOR ENGINE VALVES	-	-	-	-
	CRANKSHAFT RHQ	-	-	-	-
	IGNITION CONTROLLER DIGITRONIC FOR VEHICLES WITHOUT IMMOBILIZER	-	-	-	-
	IGNITION CONTROLLER DIGITRONIC FOR VEHICLES WITH IMMOBILIZER	-	-	-	-
	FORCE MASTER INJECTION CONTROLLER	-	-	-	-
	TC UNIT O2 controller LAMBDA EMULATOR	-	-	-	-
	MULTIVAR 2000 VARIATOR	5114404	5114730	5114404	5111838
	MULTIVAR 2000 MHR	€ 112,35	€ 144,20	€ 112,35	€ 127,65
	X SPECIAL BELT BELT	6113148	6115276	6113148	6113028
	X K BELT BELT	€ 26,40	€ 63,24	€ 26,40	€ 53,76
	HTRoll	6611095.MO	66 9917.E0	6611095.MO	66 9917.Q0
	ROLLERS FOR MULTIVAR 2000 / MHR	€ 13,64 gr.11,5	€ 19,12 gr.15	€ 13,64 gr.11,5	€ 19,12 gr.20
	HTRoll	6614705.F0	66 9919.H0	6614705.F0	66 9917.Q0
	ROLLERS FOR ORIGINAL VARIATOR	€ 16,50 gr.14	€ 22,15 gr.12	€ 16,50 gr.14	€ 19,12 gr.20
	VENTILVAR 2000 FIXED HALF-PULLEY	-	-	-	-
	VARIABLE-SPEED DRIVE ADJUSTER SPRING PG. 445 FOR VARIATOR	PG.445	2914712.W0 *PG* € 14,19	PG.445	2911074.Y0 *PG* € 10,71
	TORSION CONTROLLER ANTIFRICTION FIFTH WHEEL	-	-	-	-
	TORQUE DRIVER MOBILE DRIVEN SPLIT PULLEY	-	-	-	-
	OVER RANGE TRANSMISSION KIT	-	-	-	-
	MAXI FLY CLUTCH NOT ADJUSTABLE CLUTCH	5212522 € 70,37 Ø 125	-	5212522 € 70,37 Ø 125	-
	MAXI DELTA CLUTCH ADJUSTABLE CLUTCH	5212487 € 112,59 Ø 125	-	5212487 € 112,59 Ø 125	-
	MAXI CLUTCH BELL CLUTCH BELL (SMOOTH RING)	7714325 € 33,00 Ø 125	-	7714325 € 33,00 Ø 125	-
	MAXI WING CLUTCH BELL CLUTCH BELL (FINNED RING)	-	7715900B € 59,00 Ø 153	-	7715900B € 59,00 Ø 153
	MAXI FLY SYSTEM CLUTCH BELL + NOT ADJUSTABLE CLUTCH	5214724 € 100,47 Ø 125	-	5214724 € 100,47 Ø 125	-
	MAXI DELTA SYSTEM CLUTCH BELL + ADJUSTABLE CLUTCH	-	-	-	-
	SPRINGS FOR MAXI FLY CLUTCH	29 9605 € 16,20	-	29 9605 € 16,20	-
	SPRINGS FOR MAXI DELTA CLUTCH	29 9605 € 16,20	-	29 9605 € 16,20	-
	SPRINGS FOR ORIGINAL CLUTCH	2912536 € 15,56	2915089 € 16,20	2912536 € 15,56	-

PG - SPECIFICATIONS on the PAGE indicated in the TITLE of the LINE



MALOSSI

Maxi Scooter

125 → 800 4T

with ENGINE **KYMCO**

PEOPLE

PEOPLE GTI
ie euro 3

PEOPLE S

PEOPLE -
PEOPLE S
euro 2

(BF40)

(BA 40)

150 4T



200 4T

LC











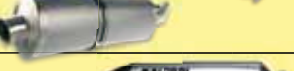





















200 4T





250 4T

LC

() CHECK "TYPE" SPECIFICATION (HOMOLOGATION MARK).

	CLUTCH DISK SET FOR ORIGINAL CLUTCH		-	-	-	-
	MAXI WILD LION   HOMOLOGATED EXHAUST SYSTEM		-	-	-	-
	RX   HOMOLOGATED EXHAUST SYSTEM		-	-	-	-
	RED CHILLI OIL OIL FILTER		-	-	-	-
	RED SPONGE FOR ORIGINAL AIR BOX		-	-	-	-
	DOUBLE RED SPONGE FOR ORIGINAL AIR BOX		-	-	-	-
	W BOX FOR ORIGINAL AIR BOX		-	-	-	-
	V FILTER VARIATOR AIR FILTER RIGHT SIDE		-	-	-	-
	POWER TRASMISSION		-	-	-	-
	GEARS HTQ PRIMARY		-	-	-	-
	GEARS HTQ SECONDARY		-	-	-	-
	SPORT SCREEN SCREEN		-	-	-	-
	MHR SCREEN SCREEN		-	-	-	-
	HOSE KIT FOR BRAKE		-	-	-	-
	BRAKE PADS FRONT ORGANIC BRAKE PADS	6215858 € 8,84 2003->	6216938 € 14,00	6215858 € 8,84 2007->	-	-
	BRAKE PADS MHR FRONT ORGANIC BRAKE PADS	-	-	-	-	-
	BRAKE PADS MHR SYNT FRONT SINTERED BRAKE PADS	-	6215037 € 20,00	-	-	-
	BRAKE PADS REAR ORGANIC BRAKE PADS	-	-	6216899 € 9,50	6216899 € 9,50	-
	BRAKE PADS MHR REAR ORGANIC BRAKE PADS	-	-	-	-	-
	BRAKE PADS MHR SYNT REAR SINTERED BRAKE PADS	-	-	6215028 € 20,00	6215028 € 20,00	-
	BRAKE POWER REAR BRAKE SHOES	-	-	-	-	-
	DISC / WHOOP DISC / PAIR WHOOP FRONT BRAKE DISC	-	-	-	-	-
	DISC / WHOOP DISC REAR BRAKE DISC	-	-	-	-	-
	TWINS MAXI SUSPENSIONS REAR PAIR SHOCK ABSORBER	-	-	-	-	-
	RS3 - RS1 REAR SHOCK ABSORBER	-	-	-	-	-
	RS24 REAR SHOCK ABSORBER	-	-	-	-	-
	RS24 FRONT SHOCK ABSORBER	-	-	-	-	-
	RS24 FRONT + REAR	-	-	-	-	-
	F32S FORK STEMS Ø 32	-	-	-	-	-
	F37R FORK STEMS Ø 37	-	-	-	-	-

KYMCO

PEOPLE GTi ie euro 3	PEOPLE S ie euro 3	RACING ie euro 3	RACING ie euro 3	SUPER 8 euro 3	SUPER DINK ie euro 3	SUPER DINK ie euro 3	SUPER DINK ie euro 3
(BF60)	(BB60)	(SR25B)	(SR30B)	(KL25)	(SK25)	(SK40)	(SK60)
300 4T LC	300 4T LC	125 4T LC	150 4T 	125 4T 	125 4T LC	200 4T LC	300 4T LC
-	-	-	-	-	-	-	-
-	-	-	-	-	-	-	-
-	-	-	-	-	-	-	3214808 € 380,00
-	-	-	-	-	-	-	-
-	-	-	-	-	-	-	-
-	-	-	-	-	-	-	-
-	-	-	-	-	1415336 € 45,00	1415336 € 45,00	1415336 € 45,00
-	-	-	-	-	-	-	-
-	-	-	-	-	-	-	-
-	-	-	-	-	-	-	-
-	-	-	-	-	4515116 € 62,76	4515116 € 62,76	4515116 € 62,76
-	-	-	-	-	-	-	-
6216938 € 14,00	6215055 € 8,84	-	-	6215858 € 8,84 2008->	6216890 € 9,87	6216890 € 9,87	6216890 € 9,87
-	6215078 € 8,84	-	-	-	-	-	-
6215037 € 20,00	-	-	-	-	6215027 € 16,64	6215027 € 16,64	6215027 € 16,64
-	6216899 € 9,50	-	-	-	-	-	-
-	-	-	-	-	-	-	-
-	6215028 € 20,00	-	-	-	-	-	-
-	-	-	-	-	-	-	-
-	-	-	-	-	-	-	-
-	-	-	-	-	-	-	-
-	-	-	-	-	-	-	-
-	-	-	-	-	-	-	-
-	-	-	-	-	-	-	-
-	-	-	-	-	-	-	-
-	-	-	-	-	-	-	-
-	-	-	-	-	-	-	-
-	-	-	-	-	-	-	-
-	-	-	-	-	-	-	-
-	-	-	-	-	-	-	-
-	-	-	-	-	-	-	-
-	-	-	-	-	-	-	-

MAXI SCOOTER 125 → 800 4T





MALOSSI

Maxi Scooter

125 → 800 4T

with ENGINE **KYMCO**SUPER DINK
ie euro 3
2012->

VIVIO

VIVIO

XCITING
euro 2

(SK60A)

300 4T

LC

125 4T



150 4T



250 4T

LC

Products to be used exclusively for racing in places specially designed for such activity according to the regulations of the competent sporting authorities. We accept no liability resulting from improper use.

	CYLINDER 4 STROKE ALUMINIUM	-	-	-	-
	CYLINDER I-TECH ALUMINIUM EQUIPPED WITH CDI	-	-	-	-
	POWER CAM CAMSHAFT	-	-	-	-
	HEAD V4 HEAD FOR ORIGINAL CYLINDER / MALOSSI	-	-	-	-
	CYLINDER + V4 HEAD ALUMINIUM	-	-	-	-
	CYLINDER + V4 HEAD + POWER CAM ALUMINIUM Ø 75,5	-	-	-	-
	4 STROKE VALVE FOR ENGINE VALVES SET	-	-	-	-
	SPRINGS FOR ENGINE VALVES	-	-	-	-
	CRANKSHAFT RHQ	-	-	-	-
	IGNITION CONTROLLER DIGITRONIC FOR VEHICLES WITHOUT IMMOBILIZER	-	-	-	-
	IGNITION CONTROLLER DIGITRONIC FOR VEHICLES WITH IMMOBILIZER	-	-	-	-
	FORCE MASTER INJECTION CONTROLLER	-	-	-	-
	TC UNIT O2 controller LAMBDA EMULATOR	5516341B € 90,00	-	-	-
	MULTIVAR 2000 VARIATOR MULTIVAR 2000 MHR	5114730 € 144,20	5114404 € 112,35	5114404 € 112,35	5111838 € 127,65
	X SPECIAL BELT BELT X K BELT BELT	6115277 € 76,50	6113148 € 26,40	6113148 € 26,40	6113028 € 53,76
	HTRoll ROLLERS FOR MULTIVAR 2000 / MHR	66 9917.MO € 19,12 gr.18	6611095.G0 € 13,64 gr.09,5	6611095.MO € 13,64 gr.11,5	66 9917.Q0 € 19,12 gr.20
	HTRoll ROLLERS FOR ORIGINAL VARIATOR	66 9919.MO € 22,15 gr.14,5	6614705.D0 € 16,50 gr.13	6614705.F0 € 16,50 gr.14	66 9917.Q0 € 19,12 gr.20
	VENTILVAR 2000 FIXED HALF-PULLEY	6114701B € 44,88	-	-	-
	VARIABLE-SPEED DRIVE ADJUSTER SPRING FOR VARIATOR	PG. 445 2914712.WO *PG* € 14,19	PG.445	PG.445	2911074.YO *PG* € 10,71
	TORSION CONTROLLER ANTIFRICTION FIFTH WHEEL	-	-	-	-
	TORQUE DRIVER MOBILE DRIVEN SPLIT PULLEY	-	-	-	-
	OVER RANGE TRANSMISSION KIT	-	-	-	-
	MAXI FLY CLUTCH NOT ADJUSTABLE CLUTCH	-	5212522 € 70,37 Ø 125	5212522 € 70,37 Ø 125	-
	MAXI DELTA CLUTCH ADJUSTABLE CLUTCH	-	5212487 € 112,59 Ø 125	5212487 € 112,59 Ø 125	-
	MAXI CLUTCH BELL CLUTCH BELL (SMOOTH RING)	-	7714325 € 33,00 Ø 125	7714325 € 33,00 Ø 125	-
	MAXI WING CLUTCH BELL CLUTCH BELL (FINNED RING)	-	-	-	7715900B € 59,00 Ø 153
	MAXI FLY SYSTEM CLUTCH BELL + NOT ADJUSTABLE CLUTCH	-	5214724 € 100,47 Ø 125	5214724 € 100,47 Ø 125	-
	MAXI DELTA SYSTEM CLUTCH BELL + ADJUSTABLE CLUTCH	-	-	-	-
	SPRINGS FOR MAXI FLY CLUTCH	-	29 9605 € 16,20	29 9605 € 16,20	-
	SPRINGS FOR MAXI DELTA CLUTCH	-	29 9605 € 16,20	29 9605 € 16,20	-
	SPRINGS FOR ORIGINAL CLUTCH	2915089 € 16,20	-	-	-

PG - SPECIFICATIONS on the PAGE indicated in the TITLE of the LINE



MALOSSI

Maxi Scooter

125 → 800 4T

with ENGINE **KYMCO**SUPER DINK
ie euro 3
2012->

VIVIO

VIVIO

XCITING
euro 2

(SK60A)

300 4T

LC

125 4T













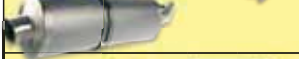

















150 4T



250 4T

LC

() CHECK "TYPE" SPECIFICATION (HOMOLOGATION MARK).

	CLUTCH DISK SET FOR ORIGINAL CLUTCH		-	-	-	-
	MAXI WILD LION () HOMOLOGATED EXHAUST SYSTEM	PG. 418	-	-	-	-
	RX () HOMOLOGATED EXHAUST SYSTEM	PG. 420	3214808 € 380,00	-	-	3214804 € 380,00
	RED CHILLI OIL OIL FILTER		-	-	-	-
	RED SPONGE FOR ORIGINAL AIR BOX		-	-	-	-
	DOUBLE RED SPONGE FOR ORIGINAL AIR BOX		-	-	-	-
	W BOX FOR ORIGINAL AIR BOX		1415336 € 45,00	-	-	-
	V FILTER VARIATOR AIR FILTER RIGHT SIDE		-	-	-	-
	POWER TRASMISSION		-	-	-	-
	GEARS HTQ PRIMARY		-	-	-	-
	GEARS HTQ SECONDARY		-	-	-	-
	SPORT SCREEN SCREEN		4515116	-	-	-
	MHR SCREEN SCREEN		€ 62,76	-	-	-
	HOSE KIT FOR BRAKE		-	-	-	-
	BRAKE PADS FRONT ORGANIC BRAKE PADS		6216890 € 9,87	-	-	6216890 € 9,87
	BRAKE PADS MHR FRONT ORGANIC BRAKE PADS		-	-	-	-
	BRAKE PADS MHR SYNT FRONT SINTERED BRAKE PADS		6215027 € 16,64	-	-	6215027 € 16,64
	BRAKE PADS REAR ORGANIC BRAKE PADS		-	-	-	6216890 € 9,87
	BRAKE PADS MHR REAR ORGANIC BRAKE PADS		-	-	-	-
	BRAKE PADS MHR SYNT REAR SINTERED BRAKE PADS		-	-	-	6215027 € 16,64
	BRAKE POWER REAR BRAKE SHOES		-	-	-	-
	DISC / WHOOP DISC / PAIR WHOOP FRONT BRAKE DISC		-	-	-	-
	DISC / WHOOP DISC REAR BRAKE DISC		-	-	-	-
	TWINS MAXI SUSPENSIONS REAR PAIR SHOCK ABSORBER		-	-	-	-
	RS3 - RS1 REAR SHOCK ABSORBER		-	-	-	-
	RS24 REAR SHOCK ABSORBER		-	-	-	-
	RS24 FRONT SHOCK ABSORBER		-	-	-	-
	RS24 FRONT + REAR		-	-	-	-
	F32S FORK STEMS Ø 32		-	-	-	-
	F37R FORK STEMS Ø 37		-	-	-	-

KYMCO							LAVERDA
XCITING - XCITING R ie euro 3	XCITING ie euro 3	XCITIN euro 2-3	XCITING R ie euro 3	YAGER GT ie euro 3	YAGER GT ie euro 3	YUP	PHOENIX
	(SK80)		(SB A0)		(SH60)	(SH 50 D)	
300 4T LC	400 4T LC	500 4T LC	500 4T LC	125 4T LC	300 4T LC	250 4T LC	125 4T 
-	-	-	-	-	-	-	-
-	-	-	-	-	-	-	-
3214804 € 380,00	3216388 € 428,00	-	-	-	-	-	-
-	-	-	-	-	-	-	-
-	-	-	-	-	-	-	-
-	-	-	-	-	-	-	-
-	-	-	-	-	-	-	-
-	-	-	-	-	-	-	-
-	-	-	-	-	-	-	-
-	-	-	-	-	-	-	-
-	-	-	-	-	-	-	-
-	4516574 € 70,00	-	-	-	-	-	-
-	-	-	-	-	-	-	-
6216890 € 9,87	-	6216890 € 9,87	6216890 € 9,87	6216890 € 9,87	6216890 € 9,87	-	-
-	-	-	-	-	-	-	-
6215027 € 16,64	-	6215027 € 16,64	6215027 € 16,64	6215027 € 16,64	6215027 € 16,64	-	-
-	-	6216890 € 9,87	6216890 € 9,87	6216899 € 9,50	6216899 € 9,50	-	6215858 € 8,84 2001->
-	-	-	-	-	-	-	-
-	-	6215027 € 16,64	6215027 € 16,64	6215028 € 20,00	6215028 € 20,00	-	-
-	-	-	-	-	-	-	-
-	-	-	-	-	-	-	-
-	-	-	-	-	-	-	-
-	-	-	-	-	-	-	-
-	-	-	-	-	-	-	-
-	-	-	-	-	-	-	-
-	-	-	-	-	-	-	-
-	-	-	-	-	-	-	-
-	-	-	-	-	-	-	-
-	-	-	-	-	-	-	-
-	-	-	-	-	-	-	-

MAXI SCOOTER 125 → 800 4T



MALOSSI

Maxi Scooter

125 → 800 4T

with ENGINE 

LAVERDA

LML

LINHAI

PHOENIX

STAR Delux

STAR Delux

MONARCH

(E25)

(E25)

150 4T



125 4T



150 4T







125 4T



Products to be used exclusively for racing in places specially designed for such activity according to the regulations of the competent sporting authorities. We accept no liability resulting from improper use.

	CYLINDER 4 STROKE ALUMINIUM	-	-	-	-
	CYLINDER I-TECH ALUMINIUM EQUIPPED WITH CDI	-	-	-	-
	POWER CAM CAMSHAFT	-	-	-	-
	HEAD V4 HEAD FOR ORIGINAL CYLINDER / MALOSSİ	-	-	-	-
	CYLINDER + V4 HEAD ALUMINIUM	-	-	-	-
	CYLINDER + V4 HEAD + POWER CAM ALUMINIUM Ø 75,5	-	-	-	-
	4 STROKE VALVE FOR ENGINE VALVES SET	-	-	-	-
	SPRINGS FOR ENGINE VALVES	-	-	-	-
	CRANKSHAFT RHQ	-	-	-	-
	IGNITION CONTROLLER DIGITRONIC FOR VEHICLES WITHOUT IMMOBILIZER	-	-	-	-
	IGNITION CONTROLLER DIGITRONIC FOR VEHICLES WITH IMMOBILIZER	-	-	-	-
	FORCE MASTER INJECTION CONTROLLER	-	-	-	-
	TC UNIT O2 controller LAMBDA EMULATOR	-	-	-	-
	MULTIVAR 2000 VARIATOR	5111869	-	-	5112133
	MULTIVAR 2000 MHR	€ 112,35	-	-	€ 110,68
	X SPECIAL BELT BELT	-	-	-	-
	X K BELT BELT	-	-	-	-
	HTRoll	6611095.I0	-	-	6611095.I0
	ROLLERS FOR MULTIVAR 2000 / MHR	€ 13,64	-	-	€ 13,64
	HTRoll	6611534.D0	-	-	6614705.D0
	ROLLERS FOR ORIGINAL VARIATOR	€ 11,00 gr.13,5	-	-	€ 16,50 gr.13
	VENTILVAR 2000 FIXED HALF-PULLEY	-	-	-	-
	VARIABLE-SPEED DRIVE ADJUSTER SPRING <small>PG. 445</small>	-	-	-	2911266.Y0 *PG* € 10,71
	TORSION CONTROLLER ANTIFRICTION FIFTH WHEEL	-	-	-	-
	TORQUE DRIVER MOBILE DRIVEN SPLIT PULLEY	-	-	-	-
	OVER RANGE TRANSMISSION KIT	-	-	-	-
	MAXI FLY CLUTCH NOT ADJUSTABLE CLUTCH	-	-	-	-
	MAXI DELTA CLUTCH ADJUSTABLE CLUTCH	-	-	-	-
	MAXI CLUTCH BELL CLUTCH BELL (SMOOTH RING)	-	-	-	-
	MAXI WING CLUTCH BELL CLUTCH BELL (FINNED RING)	-	-	-	-
	MAXI FLY SYSTEM CLUTCH BELL + NOT ADJUSTABLE CLUTCH	-	-	-	-
	MAXI DELTA SYSTEM CLUTCH BELL + ADJUSTABLE CLUTCH	-	-	-	-
	SPRINGS FOR MAXI FLY CLUTCH	-	-	-	-
	SPRINGS FOR MAXI DELTA CLUTCH	-	-	-	-
	SPRINGS FOR ORIGINAL CLUTCH	-	-	-	-

PG - SPECIFICATIONS on the PAGE indicated in the TITLE of the LINE

LINHAI		MALAGUTI					
MONARCH	BLOG ie euro 3	BLOG ie euro 3	CENTRO ie euro 3	CENTRO ie euro 3	CIAK MASTER	CIAK MASTER	CIAK MASTER
	(03)	(04)		(02)			
150 4T 	125 4T LC	160 4T LC	125 4T LC	160 4T LC	125 4T 	150 4T 	200 4T 
-	-	-	-	-	-	-	-
-	-	-	-	-	-	-	-
-	-	-	-	-	-	-	-
-	-	-	-	-	-	-	-
-	-	-	-	-	-	-	-
-	-	-	-	-	-	-	-
-	-	-	-	-	-	-	-
-	-	-	-	-	-	-	-
-	-	-	-	-	-	-	-
-	-	-	-	-	-	-	-
-	-	-	-	-	-	-	-
-	-	-	-	-	-	-	-
-	-	-	-	-	-	-	-
-	-	-	-	-	-	-	-
-	-	-	-	-	-	-	-
-	-	-	-	-	-	-	-
-	-	-	-	-	-	-	-
-	-	-	-	-	-	-	-
-	-	-	-	-	-	-	-
5112133 € 110,68	5114272 € 112,35	5114272 € 112,35	5114272 € 112,35	5114272 € 112,35	5114404 € 112,35	5114404 € 112,35	5114404 € 112,35
-	6114127 € 24,42 6116422 € 48,57	6114127 € 24,42 6116422 € 48,57	6114127 € 24,42 6116422 € 48,57	6114127 € 24,42 6116422 € 48,57	6113148 € 26,40	6113148 € 26,40	6113148 € 26,40
6611095.IO € 13,64	6611095.MO € 13,64 gr.11,5	6611095.MO € 13,64 gr.11,5	6611095.MO € 13,64 gr.11,5	6611095.MO € 13,64 gr.11,5	6611095.GO € 13,64 gr.09,5	6611095.MO € 13,64 gr.11,5	6611095.MO € 13,64 gr.11,5
6614705.DO € 16,50 gr.13	6611534.AO € 11,00 gr.10,5	6611534.AO € 11,00 gr.10,5	-	6611534.CO € 11,00 gr.12,5	6614705.DO € 16,50 gr.13	6614705.FO € 16,50 gr.14	6614705.FO € 16,50 gr.14
-	-	-	-	-	-	-	-
2911266.YO *PG* € 10,71	PG.445	PG.445	PG.445	PG.445	PG.445	PG.445	PG.445
-	-	-	-	-	-	-	-
-	-	-	-	-	-	-	-
-	-	-	-	-	-	-	-
-	5212522 € 70,37	5212522 € 70,37	5212522 € 70,37	5212522 € 70,37	5212522 € 70,37 Ø 125	5212522 € 70,37 Ø 125	5212522 € 70,37 Ø 125
-	5212487 € 112,59	5212487 € 112,59	5212487 € 112,59	5212487 € 112,59	5212487 € 112,59 Ø 125	5212487 € 112,59 Ø 125	5212487 € 112,59 Ø 125
-	7714325 € 33,00 Ø 125	7714325 € 33,00 Ø 125	7714325 € 33,00 Ø 125	7714325 € 33,00 Ø 125	7714325 € 33,00 Ø 125	7714325 € 33,00 Ø 125	7714325 € 33,00 Ø 125
-	7713376 € 38,00 Ø 125	7713376 € 38,00 Ø 125	-	-	-	-	-
-	5214724 € 100,47 Ø 125	5214724 € 100,47 Ø 125	5214724 € 100,47 Ø 125	5214724 € 100,47 Ø 125	5214724 € 100,47 Ø 125	5214724 € 100,47 Ø 125	5214724 € 100,47 Ø 125
-	5216070 € 125,46 Ø 125	5216070 € 125,46 Ø 125	-	-	-	-	-
-	29 9605 € 16,20	29 9605 € 16,20	29 9605 € 16,20	29 9605 € 16,20	29 9605 € 16,20	29 9605 € 16,20	29 9605 € 16,20
-	29 9605 € 16,20	29 9605 € 16,20	29 9605 € 16,20	29 9605 € 16,20	29 9605 € 16,20	29 9605 € 16,20	29 9605 € 16,20
-	2912536 € 15,56	2912536 € 15,56	-	-	2912536 € 15,56	2912536 € 15,56	2912536 € 15,56



MALOSSİ

Maxi Scooter

125 → 800 4T

with ENGINE

L A V E R D A
L M L
L I N H A I

PHOENIX

STAR Deluxe

STAR Deluxe

MONARCH

(E25)

(E25)

150 4T



125 4T



150 4T



125 4T



() CHECK "TYPE" SPECIFICATION (HOMOLOGATION MARK).

	CLUTCH DISK SET FOR ORIGINAL CLUTCH		-	-	-	-
	MAXI WILD LION		-	-	-	-
	RX	PG. 418	-	-	-	-
	RED CHILLI OIL OIL FILTER	PG. 420	-	-	-	-
	RED SPONGE FOR ORIGINAL AIR BOX		-	-	-	-
	DOUBLE RED SPONGE FOR ORIGINAL AIR BOX		-	-	-	-
	W BOX FOR ORIGINAL AIR BOX		-	-	-	-
	V FILTER VARIATOR AIR FILTER RIGHT SIDE		-	-	-	-
	POWER TRASMISSION		-	-	-	-
	GEARS HTQ PRIMARY		-	-	-	-
	GEARS HTQ SECONDARY		-	-	-	-
	SPORT SCREEN SCREEN		-	4515120 LIGHT SMOKE € 64,00	4515120 LIGHT SMOKE € 64,00	-
	MHR SCREEN SCREEN		-	4515122 CLEAR € 59,00	4515122 CLEAR € 59,00	-
	HOSE KIT FOR BRAKE		-	-	-	-
	BRAKE PADS FRONT ORGANIC BRAKE PADS		-	6215047 € 6,76	6215047 € 6,76	-
	BRAKE PADS MHR FRONT ORGANIC BRAKE PADS		-	62 9088 € 6,55	62 9088 € 6,55	-
	BRAKE PADS MHR SYNT FRONT SINTERED BRAKE PADS		-	-	-	-
	BRAKE PADS REAR ORGANIC BRAKE PADS		6215858 € 8,84 2001->	-	-	-
	BRAKE PADS MHR REAR ORGANIC BRAKE PADS		-	-	-	-
	BRAKE PADS MHR SYNT REAR SINTERED BRAKE PADS		-	-	-	-
	BRAKE POWER REAR BRAKE SHOES		-	-	-	-
	DISC / WHOOP DISC / PAIR WHOOP FRONT BRAKE DISC		-	6212604 € 76,38	6212604 € 76,38	-
	DISC / WHOOP DISC REAR BRAKE DISC		-	-	-	-
	TWINS MAXI SUSPENSIONS REAR PAIR SHOCK ABSORBER		-	-	-	-
	RS3 - RS1 REAR SHOCK ABSORBER		-	-	-	-
	RS24 REAR SHOCK ABSORBER		-	4615127 € 248,70	4615127 € 248,70	-
	RS24 FRONT SHOCK ABSORBER		-	4614615 € 178,50	4614615 € 178,50	-
	RS24 FRONT + REAR		-	-	-	-
	F32S FORK STEMS Ø 32		-	-	-	-
	F37R FORK STEMS Ø 37		-	-	-	-



MALOSSİ

Maxi Scooter

125 → 800 4T

with ENGINE **MALAGUTI**

F18 WARRIOR

F18 WARRIOR

MADISON

MADISON 3

(YAMAHA)

(PIAGGIO)

125 4T

LC

150 4T

LC

125 4T

LC

125 4T

LC

	CYLINDER 4 STROKE ALUMINIUM	-	-	3111248 € 295,09 Ø 63	3113955 € 335,00 Ø 75,5
	CYLINDER I-TECH ALUMINIUM EQUIPPED WITH CDI	-	-	-	-
	POWER CAM CAMSHAFT	-	-	5911854 € 162,39	*62*
	HEAD V4 HEAD FOR ORIGINAL CYLINDER / MALOSSİ	-	-	-	*01*
	CYLINDER + V4 HEAD ALUMINIUM	-	-	-	-
	CYLINDER + V4 HEAD + POWER CAM ALUMINIUM Ø 75,5	-	-	-	3116208 € 895,00
	4 STROKE VALVE FOR ENGINE VALVES SET	-	-	-	2714047 € 118,53
	SPRINGS FOR ENGINE VALVES	-	-	-	2912834 € 21,54
	CRANKSHAFT RHQ	-	-	-	5312853 € 380,00
	IGNITION CONTROLLER DIGITRONIC FOR VEHICLES WITHOUT IMMOBILIZER	-	-	-	5512524 € 170,46
	IGNITION CONTROLLER DIGITRONIC FOR VEHICLES WITH IMMOBILIZER	-	-	-	5512341 € 170,46
	FORCE MASTER INJECTION CONTROLLER	-	-	-	-
	TC UNIT O2 controller LAMBDA EMULATOR	-	-	-	-
	MULTIVAR 2000 VARIATOR	5111260 € 112,35	5111260 € 112,35	5111314 € 112,35	5111397 € 112,35
	MULTIVAR 2000 MHR				
	X SPECIAL BELT BELT	6116215 € 31,00	6116215 € 31,00	6116101 € 42,50	6116117 € 34,27
	X K BELT BELT				
	HTRoll ROLLERS FOR MULTIVAR 2000 / MHR	6611095.G0 € 13,64 gr.09,5	6611095.G0 € 13,64 gr.09,5	6611095.DO+.IO € 13,64 gr.08 (3) +10,5 (3)	6611095.G0 € 13,64 gr.09,5
	HTRoll ROLLERS FOR ORIGINAL VARIATOR	-	-	6611156.CO € 20,11 gr.09	-
	VENTILVAR 2000 FIXED HALF-PULLEY	-	-	6111703 € 36,72	-
	VARIABLE-SPEED DRIVE ADJUSTER SPRING FOR VARIATOR	PG. 445 2911384.Y0 *PG* € 10,71	2911384.Y0 *PG* € 10,71	2912647.Y0 *PG* € 10,00	PG.445
	TORSION CONTROLLER ANTIFRICTION FIFTH WHEEL	-	-	-	2513210 € 5,72
	TORQUE DRIVER MOBILE DRIVEN SPLIT PULLEY	-	-	6111660 € 123,88	6111656 € 123,88
	OVER RANGE TRANSMISSION KIT	-	-	-	-
	MAXI FLY CLUTCH NOT ADJUSTABLE CLUTCH	-	-	-	-
	MAXI DELTA CLUTCH ADJUSTABLE CLUTCH	-	-	-	5211821 € 120,42
	MAXI CLUTCH BELL CLUTCH BELL (SMOOTH RING)	-	-	7714335 € 41,00 Ø 120	-
	MAXI WING CLUTCH BELL CLUTCH BELL (FINNED RING)	-	-	-	7715898B € 52,00 Ø 134
	MAXI FLY SYSTEM CLUTCH BELL + NOT ADJUSTABLE CLUTCH	-	-	-	-
	MAXI DELTA SYSTEM CLUTCH BELL + ADJUSTABLE CLUTCH	-	-	-	5216918 € 136,00 Ø 134
	SPRINGS FOR MAXI FLY CLUTCH	-	-	-	-
	SPRINGS FOR MAXI DELTA CLUTCH	-	-	-	2911326 € 17,00
	SPRINGS FOR ORIGINAL CLUTCH	-	-	2911325 € 17,24	2911326 € 17,00

01 - TO COUPLE ONLY with MALOSSİ CYLINDERS: 3813273 € 475,00

62 - TO COUPLE ONLY with MALOSSİ CYLINDERS : 5911962 € 218,53

PG - SPECIFICATIONS on the PAGE indicated in the TITLE of the LINE

MALAGUTI

127

MADISON	MADISON	MADISON	MADISON	MADISON 3	MADISON RS	MADISON K	PassWord CK
(YAMAHA)	(PIAGGIO)	(PIAGGIO)	(YAMAHA)	(PIAGGIO)	(PIAGGIO M237M)		
150 4T LC	180 4T LC	200 4T LC	250 4T LC	250 4T LC	250 4T LC	400 4T LC	250 4T LC
3111248 € 295,09 Ø 63	3113955 € 335,00 Ø 75,5	3113955 € 335,00 Ø 75,5	31 9578 € 363,37 Ø 74	3113928 € 335,00 Ø 74	3113928 € 335,00 Ø 74	-	31 9578 € 363,37 Ø 74
-	-	-	-	-	-	-	-
5911854 € 162,39	5911962 € 218,53	5911962 € 218,53	5911517 € 196,11	-	-	-	-
-	*01*	*01*	-	3813273 € 475,00	3813273 € 475,00	-	-
-	-	-	-	3113927 € 745,00 Ø 74	3113927 € 745,00 Ø 74	-	-
-	3116208 € 895,00	3116208 € 895,00	-	-	-	-	-
-	2714047 € 118,53	2714047 € 118,53	2711824 € 77,38	2714047 € 118,53	2714047 € 118,53	-	2711824 € 77,38
-	2912834 € 21,54	2912834 € 21,54	-	2912834 € 21,54	2912834 € 21,54	-	-
-	5312896 € 380,00	5312896 € 380,00	-	-	-	-	-
-	5512524 € 170,46	5512524 € 170,46	-	-	-	-	-
-	5512341 € 170,46	5512341 € 170,46	-	-	-	-	-
-	-	-	-	5515724 € 255,84	5515724 € 255,84	-	-
-	-	-	-	-	-	-	-
5113134 € 112,35	5111594 € 112,35	5111885 € 112,35	5111225 € 121,97	5111885 € 112,35	5111885 € 112,35	5114258 € 149,35	5111225 € 121,97
6116101 € 42,50	6115666 € 46,92	6115666 € 46,92	6116094 € 40,00	6113027 € 59,12	6113027 € 59,12	6113021 € 87,10	6112714 € 55,71
6611095.D0+.I0 € 13,64 gr.08 (3) +10,5 (3)	6611095.R0 € 13,64 gr.14	6611095.R0 € 13,64 gr.14	66 9919.G0 € 22,15 gr.11	6611095.T0 € 13,64 gr.15	6611095.T0 € 13,64 gr.15	6611367.E0 € 23,75 gr.16	66 9919.G0 € 22,15 gr.11
6611156.E0 € 20,11 gr.10	6613697.F0 € 18,00 gr.10	6613697.I0 € 18,00 gr.11	66 9919.L0 € 22,15 gr.14	6613697.I0 € 18,00 gr.11	6613697.I0 € 18,00 gr.11	6611367.G0 € 23,75 gr.18	66 9919.H0 € 22,15 gr.12
6111703 € 36,72	-	-	6111102B € 36,72	-	-	-	6111102B € 36,72
2912647.Y0 *PG* € 10,00	PG.445	PG.445	PG.445	PG.445	PG.445	2911429.Y0 *PG* € 11,50	29 9975.Y0 *PG* € 10,71
-	2513210 € 5,72	2513210 € 5,72	-	2513210 € 5,72	2513210 € 5,72	-	-
6111660 € 123,88	6111656 € 123,88	6112563 2003-> € 197,30 6111656 <-2002 € 123,88	6111763 € 159,12	6112563 € 197,30	6112563 € 197,30	-	6111763 € 159,12
-	-	-	-	-	-	-	-
-	-	-	-	-	-	-	-
5211888 € 120,42	5211821 € 120,42	5211821 € 120,42	5211468 € 129,23	5211821 € 120,42	5211821 € 120,42	-	5211835 € 128,41
7713368 € 59,00 Ø 135	-	-	7713368 € 59,00 Ø 135	-	-	7714329 € 115,00 Ø 150	7713369 € 56,50 Ø 145
-	7715898B € 52,00 Ø 134	7715898B € 52,00 Ø 134	-	7715898B € 52,00 Ø 134	7715898B € 52,00 Ø 134	-	-
-	-	-	-	-	-	-	-
-	5216918 € 136,00 Ø 134	5216918 € 136,00 Ø 134	-	5216918 € 136,00 Ø 134	5216918 € 136,00 Ø 134	-	5214721 € 137,70 Ø 145
-	-	-	-	-	-	-	-
2911326 € 17,00	2911326 € 17,00	2911326 € 17,00	2911326 € 17,00	2911326 € 17,00	2911326 € 17,00	-	2911848 € 17,00
2911326 € 17,00	2911326 € 17,00	2911326 € 17,00	2911325 € 17,24	2911326 € 17,00	2911326 € 17,00	-	2911848 € 17,00

MAXI SCOOTER 125 → 800 4T



MALOSSİ

Maxi Scooter

125 → 800 4T

with ENGINE **MALAGUTI**

F18 WARRIOR

F18 WARRIOR

MADISON

MADISON 3

(YAMAHA)

(PIAGGIO)

() CHECK "TYPE" SPECIFICATION (HOMOLOGATION MARK).

125 4T

LC

150 4T











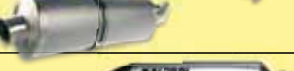



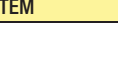















LC

125 4T

LC

125 4T

LC

	CLUTCH DISK SET FOR ORIGINAL CLUTCH		-	-	-	-
	MAXI WILD LION  HOMOLOGATED EXHAUST SYSTEM	 PG. 418	-	-	-	-
	RX  HOMOLOGATED EXHAUST SYSTEM	 PG. 420	-	-	-	-
	RED CHILLI OIL OIL FILTER		-	-	-	0313382 € 7,00
	RED SPONGE FOR ORIGINAL AIR BOX		-	-	-	1412129 € 5,10
	DOUBLE RED SPONGE FOR ORIGINAL AIR BOX		-	-	-	1414496 € 7,35
	W BOX FOR ORIGINAL AIR BOX		-	-	-	-
	V FILTER VARIATOR AIR FILTER RIGHT SIDE		-	-	-	-
	POWER TRASMISSION		-	-	-	-
	GEARS HTQ PRIMARY		-	-	-	-
	GEARS HTQ SECONDARY		-	-	6711238 € 68,58 z 14/43 <-2000	6711860 € 60,41 z 16/42
	SPORT SCREEN SCREEN		-	-	-	-
	MHR SCREEN SCREEN		-	-	-	-
	HOSE KIT FOR BRAKE		-	-	-	-
	BRAKE PADS FRONT ORGANIC BRAKE PADS		-	-	-	-
	BRAKE PADS MHR FRONT ORGANIC BRAKE PADS		-	-	-	-
	BRAKE PADS MHR SYNT FRONT SINTERED BRAKE PADS		6215009 € 14,50	6215009 € 14,50 2001->	-	-
	BRAKE PADS REAR ORGANIC BRAKE PADS		-	-	-	-
	BRAKE PADS MHR REAR ORGANIC BRAKE PADS		-	-	-	-
	BRAKE PADS MHR SYNT REAR SINTERED BRAKE PADS		6215019 € 16,64 2001->	6215019 € 16,64 2001->	6215019 € 16,64 1999->	-
	BRAKE POWER REAR BRAKE SHOES		-	-	-	-
	DISC / WHOOP DISC / PAIR WHOOP FRONT BRAKE DISC		-	-	6212349 € 74,50 1999->	-
	DISC / WHOOP DISC REAR BRAKE DISC		-	-	-	-
	TWINS MAXI SUSPENSIONS REAR PAIR SHOCK ABSORBER		-	-	-	-
	RS3 - RS1 REAR SHOCK ABSORBER		-	-	-	-
	RS24 REAR SHOCK ABSORBER		-	-	-	-
	RS24 FRONT SHOCK ABSORBER		-	-	-	-
	RS24 FRONT + REAR		-	-	-	-
	F32S FORK STEMS Ø 32		-	-	-	-
	F37R FORK STEMS Ø 37		-	-	-	-

MALAGUTI

129

MADISON	MADISON	MADISON	MADISON	MADISON 3	MADISON RS	MADISON K	PassWord CK
(YAMAHA)	(PIAGGIO)	(PIAGGIO)	(YAMAHA)	(PIAGGIO)	(PIAGGIO M237M)		
150 4T LC	180 4T LC	200 4T LC	250 4T LC	250 4T LC	250 4T LC	400 4T LC	250 4T LC
-	-	-	-	-	-	-	-
-	-	-	-	-	-	-	-
-	-	-	-	-	-	-	-
-	0313382 € 7,00	0313382 € 7,00	-	0313382 € 7,00	0313382 € 7,00	-	-
-	-	-	1411417 € 9,06	1412129 € 5,10	1412129 € 5,10	-	-
-	-	-	1414502 € 7,35	1414496 € 7,35	1414496 € 7,35	-	-
-	-	-	-	-	-	-	-
-	-	-	-	-	-	-	-
-	-	-	-	-	-	-	-
-	6711860 € 60,41 z 16/42	6711860 € 60,41 z 16/42	67 9974 € 90,27 z 17/37	-	-	-	-
-	-	-	-	-	-	-	-
-	-	-	-	-	-	-	-
-	-	-	6216890 € 9,87 1999->	-	-	-	-
-	-	-	-	-	-	-	-
-	6215011 € 16,00	-	6215037 € 20,00 1999->	-	6215011 € 16,00	-	6215011 € 16,00
-	-	-	-	-	-	-	-
-	-	-	-	-	-	-	-
6215019 € 16,64 1999->	6215019 € 16,64	-	6215019 € 16,64 1999->	-	6215019 € 16,64	-	6215019 € 16,64
-	-	-	-	-	-	-	-
6212349 € 74,50 2000->	6212349 € 74,50 2001->	-	-	-	6212349 € 74,50	-	-
-	6212349 € 74,50 2001->	-	6212349 € 74,50 1999->	-	6212349 € 74,50	-	-
-	4613167 € 230,00	4613167 € 230,00	-	-	-	-	4613169 € 243,00
-	-	-	-	-	-	-	-
-	-	-	-	-	-	-	-
-	-	-	-	-	-	-	-
-	-	-	-	-	-	-	-
-	-	-	-	-	-	-	-
-	-	-	-	-	-	-	-

MAXI SCOOTER 125 → 800 4T



MALOSSI

Maxi Scooter

125 → 800 4T

with ENGINE **MALAGUTI**

PHANTOM MAX

PHANTOM MAX

PHANTOM MAX

SPIDERMAX GT







(YAMAHA)

(PIAGGIO)

(PIAGGIO M361M)

(PIAGGIO M341M)

125 4T **LC**200 4T **LC**250 4T **LC**500 4T **LC**

	CYLINDER 4 STROKE ALUMINIUM	3111248 € 295,09 Ø 63	3113955 € 335,00 Ø 75,5	3113928 € 335,00 Ø 74	-
	CYLINDER I-TECH ALUMINIUM EQUIPPED WITH CDI	-	-	-	-
	POWER CAM CAMSHAFT	5911854 € 162,39	5911962 € 218,53	-	5913846 € 227,63
	HEAD V4 HEAD FOR ORIGINAL CYLINDER / MALOSSI	-	*01*	3813273 € 475,00	-
	CYLINDER + V4 HEAD ALUMINIUM	-	-	3113927 € 745,00 Ø 74	-
	CYLINDER + V4 HEAD + POWER CAM ALUMINIUM Ø 75,5	-	3116208 € 895,00	-	-
	4 STROKE VALVE FOR ENGINE VALVES SET	-	2714047 € 118,53	2714047 € 118,53	-
	SPRINGS FOR ENGINE VALVES	-	2912834 € 21,54	2912834 € 21,54	2913068 € 22,74
	CRANKSHAFT RHQ	-	5312896 € 380,00	-	-
	IGNITION CONTROLLER DIGITRONIC FOR VEHICLES WITHOUT IMMOBILIZER	-	5512524 € 170,46	-	-
	IGNITION CONTROLLER DIGITRONIC FOR VEHICLES WITH IMMOBILIZER	-	5512341 € 170,46	-	-
	FORCE MASTER INJECTION CONTROLLER	-	-	5515724 € 255,84	-
	TC UNIT O2 controller LAMBDA EMULATOR	-	-	-	-
	MULTIVAR 2000 VARIATOR MULTIVAR 2000 MHR	5113134 € 112,35	5111885 € 112,35	5111885 € 112,35	5114260 (8 rollers) € 173,04 5111808 (6 rollers) € 172,79
	X SPECIAL BELT BELT X K BELT BELT	6116101 € 42,50	6115666 € 46,92	6113027 € 59,12	6115125 € 88,54
	HTRoll ROLLERS FOR MULTIVAR 2000 / MHR	6611095.DO+.IO € 13,64 gr.08 (3) +10,5 (3)	6611095.R0 € 13,64 gr.14	6611095.T0 € 13,64 gr.15	6613554.B0 gr.15 (8) € 26,00 6613968.A0 gr.20 (6) € 17,81
	HTRoll ROLLERS FOR ORIGINAL VARIATOR	6611156.CO € 20,11 gr.09	6613697.IO € 18,00 gr.11	6613697.IO € 18,00 gr.11	6613968.E0 € 17,81 gr.28 (6 rollers)
	VENTILVAR 2000 FIXED HALF-PULLEY	-	-	-	-
	VARIABLE-SPEED DRIVE ADJUSTER SPRING FOR VARIATOR	PG. 445 2912647.Y0 *PG* € 10,00	PG.445	PG.445	PG.445
	TORSION CONTROLLER ANTIFRICTION FIFTH WHEEL	-	2513210 € 5,72	2513210 € 5,72	-
	TORQUE DRIVER MOBILE DRIVEN SPLIT PULLEY	-	6112563 € 197,30	6112563 € 197,30	-
	OVER RANGE TRANSMISSION KIT	-	-	-	-
	MAXI FLY CLUTCH NOT ADJUSTABLE CLUTCH	-	-	-	5212813 € 146,14
	MAXI DELTA CLUTCH ADJUSTABLE CLUTCH	-	5211821 € 120,42	5211821 € 120,42	-
	MAXI CLUTCH BELL CLUTCH BELL (SMOOTH RING)	-	-	-	-
	MAXI WING CLUTCH BELL CLUTCH BELL (FINNED RING)	-	7715898B € 52,00 Ø 134	7715898B € 52,00 Ø 134	7715898B € 52,00 Ø 134
	MAXI FLY SYSTEM CLUTCH BELL + NOT ADJUSTABLE CLUTCH	-	-	-	5216202 € 149,94 Ø 160
	MAXI DELTA SYSTEM CLUTCH BELL + ADJUSTABLE CLUTCH	-	5216918 € 136,00 Ø 134	5216918 € 136,00 Ø 134	-
	SPRINGS FOR MAXI FLY CLUTCH	-	-	-	2913137 € 20,99
	SPRINGS FOR MAXI DELTA CLUTCH	-	2911326 € 17,00	2911326 € 17,00	-
	SPRINGS FOR ORIGINAL CLUTCH	2911325 € 17,24	2911326 € 17,00	2911326 € 17,00	2912779 (5 masses) € 21,00 2911326 (3 masses) € 15,94

01 - TO COUPLE ONLY with MALOSSI CYLINDERS: 3813273 € 475,00

64 - TO COUPLE ONLY with MALOSSI CYLINDERS : 5913877 € 229,69

PG - SPECIFICATIONS on the PAGE indicated in the TITLE of the LINE

MBK

CITYLINER ie euro 3	D00D0	D00D0	FLAME	KILIBRE	SKYCRUISER ie euro 3	SKYLINER	SKYLINER
				(H314E)			
125 4T LC	125 4T LC	150 4T LC	125 4T 	300 4T LC	125 4T LC	125 4T LC	150 4T LC
-	3111248 € 295,09 Ø 63	3111248 € 295,09 Ø 63	-	31 9578 € 363,37 Ø 74	-	3111248 € 295,09 Ø 63	3111248 € 295,09 Ø 63
3114443 € 530,45 Ø 63	-	-	-	-	3114443 € 530,45 Ø 63	-	-
64	5911854 € 162,39	5911854 € 162,39	-	5911517 € 196,11	*64*	5911854 € 162,39	5911854 € 162,39
-	-	-	-	-	-	-	-
-	-	-	-	-	-	-	-
-	-	-	-	-	-	-	-
-	-	-	-	2711824 € 77,38	-	-	-
-	-	-	-	-	-	-	-
-	-	-	-	-	-	-	-
-	-	-	-	-	-	-	-
-	-	-	-	-	-	-	-
5113134 € 112,35	5113134 € 112,35	5113134 € 112,35	5111567 € 112,35	5111225 € 121,97	5113134 € 112,35	5113134 € 112,35	5113134 € 112,35
6113059 € 59,36	6116101 € 42,50	6116101 € 42,50	-	6112714 € 55,71	6113059 € 59,36	6116101 € 42,50	6116101 € 42,50
6611095.D0 € 13,64 gr.08	6611095.D0+.I0 € 13,64 gr.08 (3) +10,5 (3)	6611095.D0+.I0 € 13,64 gr.08 (3) +10,5 (3)	6611095.E0 € 13,64 gr.08,5	66 9919.G0 € 22,15 gr.11	6611095.D0 € 13,64 gr.08	6611095.D0+.I0 € 13,64 gr.08 (3) +10,5 (3)	6611095.D0+.I0 € 13,64 gr.08 (3) +10,5 (3)
6611156.E0 € 20,11 gr.10	6611156.C0 € 20,11 gr.09	6611156.E0 € 20,11 gr.10	-	66 9919.M0 € 22,15 gr.14,5	6611156.E0 € 20,11 gr.10	6611156.C0 € 20,11 gr.09	6611156.E0 € 20,11 gr.10
6111703 € 36,72	6111703 € 36,72	6111703 € 36,72	-	6111102B € 36,72	6111703 € 36,72	6111703 € 36,72	6111703 € 36,72
2912647.Y0 *PG* € 10,00	2912647.Y0 *PG* € 10,00	2912647.Y0 *PG* € 10,00	2912647.Y0 *PG* € 10,00	29 9975.Y0 *PG* € 10,71	2912647.Y0 *PG* € 10,00	2912647.Y0 *PG* € 10,00	2912647.Y0 *PG* € 10,00
-	-	-	-	-	-	-	-
6111660 € 123,88	6111660 € 123,88	6111660 € 123,88	-	6111763 € 159,12	6111660 € 123,88	6111660 € 123,88	6111660 € 123,88
-	-	-	-	-	-	-	-
-	5212544 € 70,37	-	-	-	-	5212544 € 70,37	-
5211888 € 120,42	5212450 € 112,59	5211888 € 120,42	-	5211835 € 128,41	5211888 € 120,42	5212450 € 112,59	5211888 € 120,42
7713368 € 59,00 Ø 135	7714335 € 41,00 Ø 120	7713368 € 59,00 Ø 135	-	7713369 € 56,50 Ø 145	7713368 € 59,00 Ø 135	7714335 € 41,00 Ø 120	7713368 € 59,00 Ø 135
-	-	-	-	-	-	-	-
-	5214727 € 109,14 Ø 120	-	-	-	-	5214727 € 109,14 Ø 120	-
-	-	-	-	5214721 € 137,70 Ø 145	-	-	-
-	29 9605 € 16,20	-	-	-	-	29 9605 € 16,20	-
2911326 € 17,00	29 9605 € 16,20	2911326 € 17,00	-	2911848 € 17,00	2911326 € 17,00	29 9605 € 16,20	2911326 € 17,00
2911848 € 17,00	2911325 € 17,24	2911326 € 17,00	-	2911848 € 17,00	2911848 € 17,00	2911325 € 17,24	2911326 € 17,00



MALOSSI

Maxi Scooter

125 → 800 4T

with ENGINE **MALAGUTI**

PHANTOM MAX

PHANTOM MAX

PHANTOM MAX

SPIDERMAX GT

(YAMAHA)

(PIAGGIO)

(PIAGGIO M361M)

(PIAGGIO M341M)

() CHECK "TYPE" SPECIFICATION (HOMOLOGATION MARK).

125 4T

LC

200 4T











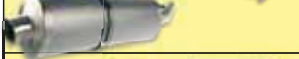





















LC

250 4T

LC

500 4T

LC

	CLUTCH DISK SET FOR ORIGINAL CLUTCH		-	-	-	-
	MAXI WILD LION   HOMOLOGATED EXHAUST SYSTEM		-	-	-	-
	RX   HOMOLOGATED EXHAUST SYSTEM		-	-	-	-
	RED CHILLI OIL OIL FILTER		-	0313382 € 7,00	0313382 € 7,00	0313383 € 7,42
	RED SPONGE FOR ORIGINAL AIR BOX		-	1412129 € 5,10	1412129 € 5,10	-
	DOUBLE RED SPONGE FOR ORIGINAL AIR BOX		-	1414496 € 7,35	1414496 € 7,35	-
	W BOX FOR ORIGINAL AIR BOX		-	-	-	-
	V FILTER VARIATOR AIR FILTER RIGHT SIDE		-	-	-	-
	POWER TRASMISSION		-	-	-	-
	GEARS HTQ PRIMARY		-	-	-	-
	GEARS HTQ SECONDARY		-	6711860 € 60,41 z 16/42	-	-
	SPORT SCREEN SCREEN		-	-	-	-
	MHR SCREEN SCREEN		-	-	-	-
	HOSE KIT FOR BRAKE		-	-	-	-
	BRAKE PADS FRONT ORGANIC BRAKE PADS		-	-	-	6215048 € 8,32
	BRAKE PADS MHR FRONT ORGANIC BRAKE PADS		-	-	-	62 9098 € 8,10
	BRAKE PADS MHR SYNT FRONT SINTERED BRAKE PADS		6215011 € 16,00	6215011 € 16,00	6215011 € 16,00	6215031 € 17,16
	BRAKE PADS REAR ORGANIC BRAKE PADS		-	-	-	6216896 € 9,50
	BRAKE PADS MHR REAR ORGANIC BRAKE PADS		-	-	-	-
	BRAKE PADS MHR SYNT REAR SINTERED BRAKE PADS		-	-	6215019 € 16,64	6215017 € 15,00
	BRAKE POWER REAR BRAKE SHOES		-	-	-	-
	DISC / WHOOP DISC / PAIR WHOOP FRONT BRAKE DISC		6212349 € 74,50	6212349 € 74,50	6212349 € 74,50	-
	DISC / WHOOP DISC REAR BRAKE DISC		6212349 € 74,50	6212349 € 74,50	6212349 € 74,50	-
	TWINS MAXI SUSPENSIONS REAR PAIR SHOCK ABSORBER		-	4613167 € 230,00	4613167 € 230,00	-
	RS3 - RS1 REAR SHOCK ABSORBER		-	-	-	-
	RS24 REAR SHOCK ABSORBER		-	-	-	-
	RS24 FRONT SHOCK ABSORBER		-	-	-	-
	RS24 FRONT + REAR		-	-	-	-
	F32S FORK STEMS Ø 32		-	-	-	-
	F37R FORK STEMS Ø 37		-	-	-	-

MBK

CITYLINER ie euro 3	D00D0	D00D0	FLAME	KILIBRE	SKYCRUISER ie euro 3	SKYLINER	SKYLINER
				(H314E)			
125 4T LC	125 4T LC	150 4T LC	125 4T 	300 4T LC	125 4T LC	125 4T LC	150 4T LC
-	-	-	-	-	-	-	-
-	-	-	-	-	-	-	-
3214827 € 380,00	-	-	-	-	3214827 € 380,00	-	-
0313826 € 6,00	-	-	-	-	0313826 € 6,00	-	-
-	-	-	-	-	-	-	-
-	-	-	-	-	-	-	-
1415338 € 45,00	-	-	-	-	1415338 € 45,00	-	-
-	-	-	-	-	-	-	-
-	-	-	-	-	-	-	-
6713301 € 97,48 z 14/43	6711238 € 68,58 z 14/43 <-2000	-	-	-	6713301 € 97,48 z 14/43	6711238 € 68,58 z 14/43 <-2000	-
-	-	-	-	-	-	-	-
-	-	-	-	-	-	-	-
6216890 € 9,87	-	-	-	-	6216897 € 8,77	6215052 € 8,00 1998->	6215052 € 8,00 2000->
-	-	-	-	-	-	6211525 € 8,20 1998->	6211525 € 8,20 2000->
6215027 € 16,64	-	-	-	6215020 € 16,00	6215023 € 17,16	6215020 € 16,00 1998->	6215020 € 16,00 2000->
-	-	-	-	-	6216896 € 9,50	-	6216896 € 9,50 2000->
-	-	-	-	-	-	-	-
-	-	-	-	6215020 € 16,00	6215017 € 15,00	-	6215017 € 15,00 2000->
-	-	-	-	-	-	-	-
-	-	-	-	-	-	-	-
-	-	-	-	4613462 € 243,00	4613171 € 253,00	4613171 € 253,00	4613171 € 253,00
-	-	-	-	-	-	-	-
-	-	-	-	-	-	-	-
-	-	-	-	-	-	-	-
-	-	-	-	-	-	-	-
-	-	-	-	-	-	-	-
-	-	-	-	-	-	-	-
-	-	-	-	-	-	-	-
-	-	-	-	-	-	-	-



MALOSSI

Maxi Scooter

125 → 800 4T

with ENGINE **MBK**

SKYLINER

THUNDER

THUNDER

X OVER
ie euro 3

(E3G3E)

250 4T

LC

125 4T

LC

150 4T

LC

125 4T



	CYLINDER 4 STROKE ALUMINIUM	31 9578 € 363,37 Ø 74	3111248 € 295,09 Ø 63	3111248 € 295,09 Ø 63	-
	CYLINDER I-TECH ALUMINIUM EQUIPPED WITH CDI	-	-	-	3113792 € 510,00 Ø 58
	POWER CAM CAMSHAFT	5911517 € 196,11	5911854 € 162,39	5911854 € 162,39	-
	HEAD V4 HEAD FOR ORIGINAL CYLINDER / MALOSSI	-	-	-	-
	CYLINDER + V4 HEAD ALUMINIUM	-	-	-	-
	CYLINDER + V4 HEAD + POWER CAM ALUMINIUM Ø 75,5	-	-	-	-
	4 STROKE VALVE FOR ENGINE VALVES SET	2711824 € 77,38	-	-	-
	SPRINGS FOR ENGINE VALVES	-	-	-	-
	CRANKSHAFT RHQ	-	-	-	-
	IGNITION CONTROLLER DIGITRONIC FOR VEHICLES WITHOUT IMMOBILIZER	-	-	-	-
	IGNITION CONTROLLER DIGITRONIC FOR VEHICLES WITH IMMOBILIZER	-	-	-	-
	FORCE MASTER INJECTION CONTROLLER	-	-	-	-
	TC UNIT O2 controller LAMBDA EMULATOR	-	-	-	-
	MULTIVAR 2000 VARIATOR MULTIVAR 2000 MHR	5111225 € 121,97	5113134 € 112,35	5113134 € 112,35	5112701 € 112,35
	X SPECIAL BELT BELT X K BELT BELT	6116094 € 40,00	6116101 € 42,50	6116101 € 42,50	-
	HTRoll ROLLERS FOR MULTIVAR 2000 / MHR	66 9919.G0 € 22,15 gr.11	6611095.DO+.IO € 13,64 gr.08 (3) +10,5 (3)	6611095.DO+.IO € 13,64 gr.08 (3) +10,5 (3)	6611095.DO € 13,64 gr.08
	HTRoll ROLLERS FOR ORIGINAL VARIATOR	66 9919.LO € 22,15 gr.14	6611156.CO € 20,11 gr.09	6611156.EO € 20,11 gr.10	6611156.HO € 20,11 gr.12
	VENTILVAR 2000 FIXED HALF-PULLEY	6111102B € 36,72	6111703 € 36,72	6111703 € 36,72	6111703 € 36,72
	VARIABLE-SPEED DRIVE ADJUSTER SPRING FOR VARIATOR	PG. 445 PG.445	2912647.YO *PG* € 10,00	2912647.YO *PG* € 10,00	2912647.YO *PG* € 10,00
	TORSION CONTROLLER ANTIFRICTION FIFTH WHEEL	-	-	-	-
	TORQUE DRIVER MOBILE DRIVEN SPLIT PULLEY	6111763 € 159,12	6111660 € 123,88	6111660 € 123,88	6112879 € 123,88
	OVER RANGE TRANSMISSION KIT	-	-	-	-
	MAXI FLY CLUTCH NOT ADJUSTABLE CLUTCH	-	5212544 € 70,37	-	5212544 € 70,37
	MAXI DELTA CLUTCH ADJUSTABLE CLUTCH	5211835 € 128,41	5212450 € 112,59	5211888 € 120,42	5212450 € 112,59
	MAXI CLUTCH BELL CLUTCH BELL (SMOOTH RING)	7713369 € 56,50 Ø 145	7714335 € 41,00 Ø 120	7713368 € 59,00 Ø 135	7714335 € 41,00 Ø 120
	MAXI WING CLUTCH BELL CLUTCH BELL (FINNED RING)	-	-	-	-
	MAXI FLY SYSTEM CLUTCH BELL + NOT ADJUSTABLE CLUTCH	-	5214727 € 109,14 Ø 120	-	5214727 € 109,14 Ø 120
	MAXI DELTA SYSTEM CLUTCH BELL + ADJUSTABLE CLUTCH	5214721 € 137,70 Ø 145	-	-	-
	SPRINGS FOR MAXI FLY CLUTCH	-	29 9605 € 16,20	-	29 9605 € 16,20
	SPRINGS FOR MAXI DELTA CLUTCH	2911848 € 17,00	29 9605 € 16,20	2911326 € 17,00	29 9605 € 16,20
	SPRINGS FOR ORIGINAL CLUTCH	2911848 € 17,00	2911325 € 17,24	2911326 € 17,00	29 9605 € 16,20

Products to be used exclusively for racing in places specially designed for such activity according to the regulations of the competent sporting authorities. We accept no liability resulting from improper use.

PG - SPECIFICATIONS on the PAGE indicated in the TITLE of the LINE

OVER		PEUGEOT						
THOR euro 3	ELYSEO	ELYSEO	GEOPOLIS ie euro 3	GEOPOLIS ie euro 3	GEOPOLIS euro 3	GeoRS ie euro 3	JET FORCE euro 3	
(LJ1P52QMI)						(PIAGGIO M28MM)		
125 4T	125 4T	150 4T	125 4T	250 4T	400 4T	300 4T	125 4T	
	LC	LC	LC	LC	LC	LC	LC	
-	-	-	-	3113928 €335,00 Ø 74	-	3113958 €335,00 Ø 75,5	-	
-	-	-	-	-	-	-	-	
-	-	-	-	-	5913846 €227,63	-	-	
-	-	-	-	3813273 €475,00	-	3813273 €475,00	-	
-	-	-	-	3113927 €745,00 Ø 74	-	3114700 €745,00 Ø 75,5	-	
-	-	-	-	-	-	-	-	
-	-	-	-	2714047 €118,53	-	2714047 €118,53	-	
-	-	-	-	2912834 €21,54	2913068 €22,74	2912834 €21,54	-	
-	-	-	-	-	-	-	-	
-	-	-	-	-	-	-	-	
-	-	-	-	5515724 €255,84	-	-	-	
-	-	-	-	5514749 €84,00	-	5514746 €90,00	-	
5114273 €112,35	5111369 €112,35	5111369 €112,35	5113365 €112,35	5111885 €112,35	5114260 €173,04	5111885 €112,35	5113365 €112,35	
-	-	-	-	6116069 €60,00	6115125 €88,54	6116069 €60,00	-	
6611095.M0 €13,64 gr.11,5	6611095.E0 €13,64 gr.08,5	6611095.E0 €13,64 gr.08,5	6611095.F0 €13,64 gr.09	6611095.T0 €13,64 gr.15	6613554.B0 €26,00 gr.15	6611095.T0 €13,64 gr.15	6611095.F0 €13,64 gr.09	
6614705.B0 €16,50 gr.10	-	-	6611095.G0 €13,64 gr.09,5	6613697.I0 €18,00 gr.11	6613554.C0 €26,00 gr.16	-	6611095.G0 €13,64 gr.09,5	
-	-	-	-	-	-	-	-	
2911266.Y0 *PG* €10,71	2911390.B0 *PG* €10,71	2911390.B0 *PG* €10,71	-	PG.445	PG.445	PG.445	-	
-	-	-	-	2513210 €5,72	-	2513210 €5,72	-	
-	-	-	-	6112563 €197,30	-	6112563 €197,30	-	
-	-	-	-	-	-	-	-	
5212522 €70,37	-	-	-	-	5212813 €146,14	-	-	
5212487 €112,59	-	-	5211821 €120,42	5211821 €120,42	-	5211821 €120,42	5211821 €120,42	
-	-	-	-	-	-	-	-	
7713376 €38,00 Ø 125	-	-	-	-	7715579B €49,00 Ø 160	7715898B €52,00 Ø 134	-	
-	-	-	-	-	5216202 €149,94 Ø 160	-	-	
5216070 €125,46 Ø 125	-	-	-	-	-	5216918 €136,00 Ø 134	-	
29 9605 €16,20	-	-	-	-	2913137 €20,99	-	-	
29 9605 €16,20	-	-	2911326 €17,00	2911326 €17,00	-	2911326 €17,00	2911326 €17,00	
29 9605 €16,20	-	-	2911326 €17,00	2911326 €17,00	2912779 €21,00	2911326 €17,00	2911326 €17,00	



MALOSSI

Maxi Scooter

125 → 800 4T

with ENGINE **MBK**

SKYLINER

THUNDER

THUNDER

X OVER
IE EURO 3

(E3G3E)

() CHECK "TYPE" SPECIFICATION (HOMOLOGATION MARK).

250 4T

LC

125 4T

































LC

150 4T

LC

125 4T



	CLUTCH DISK SET FOR ORIGINAL CLUTCH		-	-	-	-
	MAXI WILD LION  HOMOLOGATED EXHAUST SYSTEM	 PG. 418	-	-	-	-
	RX  HOMOLOGATED EXHAUST SYSTEM	 PG. 420	-	-	-	-
	RED CHILLI OIL OIL FILTER		-	-	-	-
	RED SPONGE FOR ORIGINAL AIR BOX		1411417 € 9,06	-	-	-
	DOUBLE RED SPONGE FOR ORIGINAL AIR BOX		1414502 € 7,35	-	-	-
	W BOX FOR ORIGINAL AIR BOX		-	-	-	-
	V FILTER VARIATOR AIR FILTER RIGHT SIDE		-	-	-	-
	POWER TRASMISSION		-	-	-	-
	GEARS HTQ PRIMARY		-	-	-	-
	GEARS HTQ SECONDARY		67 9974 € 90,27 z 17/37	6711238 € 68,58 z 14/43 <-2000	-	-
	SPORT SCREEN SCREEN		-	-	-	-
	MHR SCREEN SCREEN		-	-	-	-
	HOSE KIT FOR BRAKE		-	-	-	-
	BRAKE PADS FRONT ORGANIC BRAKE PADS		6216894 € 9,87 2000->	6215052 € 8,00 2001->	6215052 € 8,00 2001->	-
	BRAKE PADS MHR FRONT ORGANIC BRAKE PADS		-	6211525 € 8,20 2001->	6211525 € 8,20 2001->	-
	BRAKE PADS MHR SYNT FRONT SINTERED BRAKE PADS		6215029 € 17,16 2000->	6215020 € 16,00 2001->	6215020 € 16,00 2001->	-
	BRAKE PADS REAR ORGANIC BRAKE PADS		6216898 € 10,24 2000->	6216896 € 9,50 2001->	6216896 € 9,50 2001->	-
	BRAKE PADS MHR REAR ORGANIC BRAKE PADS		-	-	-	-
	BRAKE PADS MHR SYNT REAR SINTERED BRAKE PADS		6215021 € 17,16 2000->	6215017 € 15,00 2001->	6215017 € 15,00 2001->	-
	BRAKE POWER REAR BRAKE SHOES		-	-	-	-
	DISC / WHOOP DISC / PAIR WHOOP FRONT BRAKE DISC		6212345 € 92,00 2000->	-	-	-
	DISC / WHOOP DISC REAR BRAKE DISC		-	-	-	-
	TWINS MAXI SUSPENSIONS REAR PAIR SHOCK ABSORBER		4613171 € 253,00	-	-	-
	RS3 - RS1 REAR SHOCK ABSORBER		-	-	-	-
	RS24 REAR SHOCK ABSORBER		-	-	-	-
	RS24 FRONT SHOCK ABSORBER		-	-	-	-
	RS24 FRONT + REAR		-	-	-	-
	F32S FORK STEMS Ø 32		-	-	-	-
	F37R FORK STEMS Ø 37		-	-	-	-

OVER		PEUGEOT													
THOR euro 3		ELYSEO	ELYSEO	GEOPOLIS ie euro 3	GEOPOLIS ie euro 3	GEOPOLIS euro 3	GeoRS ie euro 3	JET FORCE euro 3							
(LJ1P52QMI)							(PIAGGIO M28MM)								
125 4T		125 4T	LC	150 4T	LC	125 4T	LC	250 4T	LC	400 4T	LC	300 4T	LC	125 4T	LC
-	-	-	-	-	-	-	-	-	-	-	-	-	-	-	-
-	-	-	-	-	-	-	-	-	-	-	-	-	-	-	-
-	-	-	-	-	-	-	-	-	-	-	-	-	-	-	-
-	-	0313384 € 4,57	-	0313384 € 4,57	-	0313384 € 4,57	-	0313382 € 7,00	-	0313383 € 7,42	-	0313382 € 7,00	-	0313384 € 4,57	-
-	-	-	-	-	-	-	-	-	-	-	-	1412129 € 5,10	-	-	-
-	-	-	-	-	-	-	-	-	-	-	-	1414496 € 7,35	-	-	-
-	-	-	-	-	-	-	-	-	-	-	-	-	-	-	-
-	-	-	-	-	-	-	-	-	-	-	-	-	-	-	-
-	-	-	-	-	-	-	-	-	-	-	-	-	-	-	-
-	-	-	-	-	-	-	-	-	-	-	-	-	-	-	-
-	-	-	-	-	-	-	-	-	-	-	-	-	-	-	-
-	-	-	-	-	-	-	-	-	-	-	-	-	-	-	-
-	-	6215051 € 5,72 1998->	-	-	-	-	-	-	-	-	-	-	-	-	-
-	-	6215076 € 6,24 1998->	-	-	-	-	-	-	-	-	-	-	-	-	-
-	-	6215005 € 11,96 1998->	-	6215011 € 16,00 2001->	-	-	-	-	-	-	-	-	-	-	-
-	-	-	-	-	-	-	-	-	-	-	-	-	-	-	-
-	-	-	-	-	-	-	-	-	-	-	-	-	-	-	-
6215019 € 16,64	-	-	-	-	-	-	-	-	-	-	-	-	-	-	-
-	-	-	-	-	-	-	-	-	-	-	-	-	-	-	-
6212603 € 72,56	-	-	-	-	-	-	-	-	-	-	-	-	-	-	-
-	-	-	-	-	-	-	-	-	-	-	-	-	-	-	-
-	-	-	-	-	-	-	-	-	-	-	-	-	-	-	-
-	-	-	-	-	-	-	-	-	-	-	-	-	-	-	-
-	-	-	-	-	-	-	-	-	-	-	-	-	-	-	-
-	-	-	-	-	-	-	-	-	-	-	-	-	-	-	-
-	-	-	-	-	-	-	-	-	-	-	-	-	-	-	-
-	-	-	-	-	-	-	-	-	-	-	-	-	-	-	-
-	-	-	-	-	-	-	-	-	-	-	-	-	-	-	-
-	-	-	-	-	-	-	-	-	-	-	-	-	-	-	-
-	-	-	-	-	-	-	-	-	-	-	-	-	-	-	-
-	-	-	-	-	-	-	-	-	-	-	-	-	-	-	-
-	-	-	-	-	-	-	-	-	-	-	-	-	-	-	-





MALOSS

Maxi Scooter

125 → 800 4T

with ENGINE 

PEUGEOT

LXR
euro 3LXR
ie euro 3METROPOLIS
ie euro 3SATELIS
euro 3

(MB)

(P6A)

(FD6)

125 4T

LC

200 4T

LC

400 4T

LC

125 4T

LC

	CYLINDER 4 STROKE ALUMINIUM	-	-	-	-
	CYLINDER I-TECH ALUMINIUM EQUIPPED WITH CDI	-	-	-	-
	POWER CAM CAMSHAFT	-	-	-	-
	HEAD V4 HEAD FOR ORIGINAL CYLINDER / MALOSS	-	-	-	-
	CYLINDER + V4 HEAD ALUMINIUM	-	-	-	-
	CYLINDER + V4 HEAD + POWER CAM ALUMINIUM Ø 75,5	-	-	-	-
	4 STROKE VALVE FOR ENGINE VALVES SET	-	-	-	-
	SPRINGS FOR ENGINE VALVES	-	-	-	-
	CRANKSHAFT RHQ	-	-	-	-
	IGNITION CONTROLLER DIGITRONIC FOR VEHICLES WITHOUT IMMOBILIZER	-	-	-	-
	IGNITION CONTROLLER DIGITRONIC FOR VEHICLES WITH IMMOBILIZER	-	-	-	-
	FORCE MASTER INJECTION CONTROLLER	-	-	-	-
	TC UNIT O2 controller LAMBDA EMULATOR	-	-	5515735 € 88,00	-
	MULTIVAR 2000 VARIATOR MULTIVAR 2000 MHR	5114273 € 112,35	5111260 € 112,35	5116679 € 164,80	5113365 € 112,35
	X SPECIAL BELT BELT X K BELT BELT	-	-	-	-
	HTRoll ROLLERS FOR MULTIVAR 2000 / MHR	6611095.M0 € 13,64 gr.11,5	6611095.Q0 € 13,64 gr.13,5	6613561.A0 € 26,00 gr.12	6611095.F0 € 13,64 gr.09
	HTRoll ROLLERS FOR ORIGINAL VARIATOR	6614705.B0 € 16,50 gr.10	-	6613561.C0 € 26,00 gr.14	6611095.G0 € 13,64 gr.09,5
	VENTILVAR 2000 FIXED HALF-PULLEY	-	-	-	-
	VARIABLE-SPEED DRIVE ADJUSTER SPRING FOR VARIATOR	PG. 445 2911266.Y0 *PG* € 10,71	-	PG.445	-
	TORSION CONTROLLER ANTIFRICTION FIFTH WHEEL	-	-	-	-
	TORQUE DRIVER MOBILE DRIVEN SPLIT PULLEY	-	-	-	-
	OVER RANGE TRANSMISSION KIT	-	-	-	-
	MAXI FLY CLUTCH NOT ADJUSTABLE CLUTCH	5212522 € 70,37	-	5212813 € 146,14	-
	MAXI DELTA CLUTCH ADJUSTABLE CLUTCH	5212487 € 112,59	-	-	5211821 € 120,42
	MAXI CLUTCH BELL CLUTCH BELL (SMOOTH RING)	-	7714325 € 33,00 Ø 125	-	-
	MAXI WING CLUTCH BELL CLUTCH BELL (FINNED RING)	7713376 € 38,00 Ø 125	-	-	-
	MAXI FLY SYSTEM CLUTCH BELL + NOT ADJUSTABLE CLUTCH	-	-	-	-
	MAXI DELTA SYSTEM CLUTCH BELL + ADJUSTABLE CLUTCH	5216070 € 125,46 Ø 125	-	-	-
	SPRINGS FOR MAXI FLY CLUTCH	29 9605 € 16,20	-	2913137 € 20,99	-
	SPRINGS FOR MAXI DELTA CLUTCH	29 9605 € 16,20	-	-	2911326 € 17,00
	SPRINGS FOR ORIGINAL CLUTCH	29 9605 € 16,20	2912536 € 15,56	2912779 € 21,00	2911326 € 17,00

70 - For vehicles WITH ORIGINAL half-pulley "marked": "GF" 2911072.W0 - "FG" 2911074.Y0 € 10,71

PG - SPECIFICATIONS on the PAGE indicated in the TITLE of the LINE

PEUGEOT						PGO	
SATELIS compressor euro 3	SATELIS euro 3	SATELIS euro 3 <-2014	SATELIS euro 3	SV	TWEET euro 3	GMAX	TIGRA
(FD6S)		(PIAGGIO)				(GY6)	(GY6)
125 4T LC	250 4T LC	400 4T LC	500 4T LC	250 4T LC	125 4T 	150 4T LC	150 4T LC
-	3113928 € 335,00 Ø 74	-	-	-	-	-	-
-	-	-	-	-	-	-	-
-	-	5913846 € 227,63	5913846 € 227,63	5911733 € 152,00	-	-	-
-	3813273 € 475,00	-	-	-	-	-	-
-	3113927 € 745,00 Ø 74	-	-	-	-	-	-
-	-	-	-	-	-	-	-
-	2714047 € 118,53	-	-	2711826 € 63,64	-	-	-
-	2912834 € 21,54	2913068 € 22,74	2913068 € 22,74	-	-	-	-
-	-	-	-	-	-	-	-
-	-	-	-	-	-	-	-
-	-	-	-	-	-	-	-
-	5515724 € 255,84	-	-	-	-	-	-
-	-	-	-	-	-	-	-
5113485 € 112,27	5111885 € 112,35	5114260 € 173,04	5114260 € 173,04	5111226 € 127,65	5114273 € 112,35	5114404 € 112,35	5114404 € 112,35
-	6113027 € 59,12	6115125 € 88,54	6115125 € 88,54	6113189 € 39,78	-	-	-
6611095.FO € 13,64 gr.09	6611095.TO € 13,64 gr.15	6613554.BO € 26,00 gr.15	6613554.BO € 26,00 gr.15	66 9917.MO € 19,12 gr.18	6611095.MO € 13,64 gr.11,5	6611095.MO € 13,64 gr.11,5	6611095.MO € 13,64 gr.11,5
6613697.IO € 18,00 gr.11	6613697.IO € 18,00 gr.11	6613554.CO € 26,00 gr.16	6613554.CO € 26,00 gr.16	-	6614705.BO € 16,50 gr.10	-	-
-	-	-	-	6111347B € 36,72	-	-	-
-	PG.445	PG.445	PG.445	*70*	2911266.YO *PG* € 10,71	PG.445	PG.445
-	2513210 € 5,72	-	-	-	-	-	-
-	6112563 € 197,30	-	-	6111964 € 177,16	-	-	-
-	-	-	-	-	-	-	-
-	-	5212813 € 146,14	5212813 € 146,14	-	5212522 € 70,37	-	-
5211835 € 128,41	5211821 € 120,42	-	-	5211467 € 129,23	5212487 € 112,59	-	-
-	-	-	-	-	-	-	-
-	-	7715579B € 49,00 Ø 160	7715579B € 49,00 Ø 160	7715916B € 52,00 Ø 135	7713376 € 38,00 Ø 125	-	-
-	-	5216202 € 149,94 Ø 160	5216202 € 149,94 Ø 160	-	-	-	-
-	-	-	-	5216184 € 136,00 Ø 135	5216070 € 125,46 Ø 125	-	-
-	-	2913137 € 20,99	2913137 € 20,99	-	29 9605 € 16,20	-	-
2911848 € 17,00	2911326 € 17,00	-	-	2911326 € 17,00	29 9605 € 16,20	-	-
2911848 € 17,00	2911326 € 17,00	2912779 € 21,00	2912779 € 21,00	2911326 € 17,00	29 9605 € 16,20	-	-



MALOSSİ

Maxi Scooter

125 → 800 4T

with ENGINE 

PEUGEOT

LXR
euro 3LXR
ie euro 3METROPOLIS
ie euro 3SATELIS
euro 3











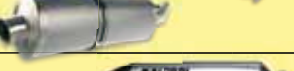















(MB)

(P6A)

(FD6)

CHECK "TYPE" SPECIFICATION (HOMOLOGATION MARK).

125 4T LC 200 4T LC 400 4T LC 125 4T LC

	CLUTCH DISK SET FOR ORIGINAL CLUTCH		-	-	-	-
	MAXI WILD LION  HOMOLOGATED EXHAUST SYSTEM	PG. 418	-	-	-	-
	RX  HOMOLOGATED EXHAUST SYSTEM	PG. 420	-	-	3216980 € 380,00	-
	RED CHILLI OIL OIL FILTER		-	-	-	0313384 € 4,57
	RED SPONGE FOR ORIGINAL AIR BOX		-	-	-	-
	DOUBLE RED SPONGE FOR ORIGINAL AIR BOX		-	-	-	-
	W BOX FOR ORIGINAL AIR BOX		-	-	-	-
	V FILTER VARIATOR AIR FILTER RIGHT SIDE		-	-	-	-
	POWER TRASMISSION		-	-	-	-
	GEARS HTQ PRIMARY		-	-	-	-
	GEARS HTQ SECONDARY		-	-	-	-
	SPORT SCREEN SCREEN		-	-	-	-
	MHR SCREEN SCREEN		-	-	-	-
	HOSE KIT FOR BRAKE		-	-	-	-
	BRAKE PADS FRONT ORGANIC BRAKE PADS		-	-	-	-
	BRAKE PADS MHR FRONT ORGANIC BRAKE PADS		-	-	-	-
	BRAKE PADS MHR SYNT FRONT SINTERED BRAKE PADS		-	-	-	6215011 € 16,00
	BRAKE PADS REAR ORGANIC BRAKE PADS		-	-	-	-
	BRAKE PADS MHR REAR ORGANIC BRAKE PADS		-	-	-	-
	BRAKE PADS MHR SYNT REAR SINTERED BRAKE PADS		-	-	-	-
	BRAKE POWER REAR BRAKE SHOES		-	-	-	-
	DISC / WHOOP DISC / PAIR WHOOP FRONT BRAKE DISC		-	-	-	-
	DISC / WHOOP DISC REAR BRAKE DISC		-	-	-	-
	TWINS MAXI SUSPENSIONS REAR PAIR SHOCK ABSORBER		-	-	-	-
	RS3 - RS1 REAR SHOCK ABSORBER		-	-	-	-
	RS24 REAR SHOCK ABSORBER		-	-	-	-
	RS24 FRONT SHOCK ABSORBER		-	-	-	-
	RS24 FRONT + REAR		-	-	-	-
	F32S FORK STEMS Ø 32		-	-	-	-
	F37R FORK STEMS Ø 37		-	-	-	-

PEUGEOT						PGO	
SATELIS compressor euro 3	SATELIS euro 3	SATELIS euro 3 <-2014	SATELIS euro 3	SV	TWEET euro 3	GMAX	TIGRA
(FD6S)		(PIAGGIO)				(GY6)	(GY6)
125 4T LC	250 4T LC	400 4T LC	500 4T LC	250 4T LC	125 4T 	150 4T LC	150 4T LC
-	-	-	-	-	-	-	-
-	-	-	-	-	-	-	-
-	-	-	-	-	-	-	-
0313384 € 4,57	0313382 € 7,00	0313383 € 7,42	0313383 € 7,42	-	-	-	-
-	-	-	-	-	-	-	-
-	-	-	-	-	-	-	-
-	-	-	-	-	-	-	-
-	-	-	-	-	-	-	-
-	-	-	-	-	-	-	-
-	-	-	-	-	-	-	-
-	-	-	-	-	-	-	-
-	-	-	-	-	-	-	-
-	-	-	-	-	67 9983 € 90,27 z 17/37	-	-
-	-	-	-	-	-	-	-
-	-	-	-	-	-	-	-
-	-	-	-	-	-	-	-
-	-	-	-	-	-	-	-
-	-	-	-	-	-	-	-
6215011 € 16,00	-	-	-	-	6215032 € 20,00 2001->	-	-
-	-	-	-	-	-	6215049 € 6,24	-
-	-	-	-	-	-	6215074 € 6,30	-
-	-	-	-	-	-	6215006 € 11,96	-
-	-	-	-	-	-	-	-
-	-	-	-	-	-	-	-
-	-	-	-	-	-	-	-
-	-	-	-	-	-	-	-
-	-	-	-	-	-	-	-
-	-	-	-	-	-	-	-
-	-	-	-	-	-	-	-
-	-	-	-	-	-	-	-
-	-	-	-	-	-	-	-
-	-	-	-	-	-	-	-
-	-	-	-	-	-	-	-
-	-	-	-	-	-	-	-
-	-	-	-	-	-	-	-

MAXI SCOOTER 125 → 800 4T



MALOSSI

Maxi Scooter

125 → 800 4T

with ENGINE 

PIAGGIO

BEVERLY
<-2009BEVERLY
ie euro 3
2010->

BEVERLY

BEVERLY
euro 1-2

(QUASAR)

(M285M)

125 4T

LC

125 4T

LC

200 4T

LC

250 4T

LC

	CYLINDER 4 STROKE ALUMINIUM	3113955 € 335,00 Ø 75,5	-	3113955 € 335,00 Ø 75,5	3113928 € 335,00 Ø 74
	CYLINDER I-TECH ALUMINIUM EQUIPPED WITH CDI	-	3116090 € 520,00 Ø 75,5	-	-
	POWER CAM CAMSHAFT	*62*	*TEC1*	5911962 € 218,53	-
	HEAD V4 HEAD FOR ORIGINAL CYLINDER / MALOSSI	*01*	*TEC1*	*01*	3813273 € 475,00
	CYLINDER + V4 HEAD ALUMINIUM	-	-	-	3113927 € 745,00 Ø 74
	CYLINDER + V4 HEAD + POWER CAM ALUMINIUM Ø 75,5	3116208 € 895,00	*TEC1*	3116208 € 895,00	-
	4 STROKE VALVE FOR ENGINE VALVES SET	2714047 € 118,53	-	2714047 € 118,53	2714047 € 118,53
	SPRINGS FOR ENGINE VALVES	2912834 € 21,54	2912834 € 21,54	2912834 € 21,54	2912834 € 21,54
	CRANKSHAFT RHQ	5312853 € 380,00	-	5312896 € 380,00	-
	IGNITION CONTROLLER DIGITRONIC FOR VEHICLES WITHOUT IMMOBILIZER	5512524 € 170,46	-	5512524 € 170,46	-
	IGNITION CONTROLLER DIGITRONIC FOR VEHICLES WITH IMMOBILIZER	5512341 € 170,46	-	5512341 € 170,46	-
	FORCE MASTER INJECTION CONTROLLER	-	-	-	5515724 € 255,84
	TC UNIT O2 controller LAMBDA EMULATOR	-	5514746 € 90,00	-	-
	MULTIVAR 2000 VARIATOR MULTIVAR 2000 MHR	5111397 € 112,35	5111397 € 112,35	5111885 € 112,35	5111885 € 112,35
	X SPECIAL BELT BELT X K BELT BELT	6116118 € 35,00	6116118 € 35,00	6116697 € 67,00	6116069 € 60,00
	HTRoll ROLLERS FOR MULTIVAR 2000 / MHR	6611095.G0 € 13,64 gr.09,5	6611095.G0 € 13,64 gr.09,5	6611095.R0 € 13,64 gr.14	6611095.T0 € 13,64 gr.15
	HTRoll ROLLERS FOR ORIGINAL VARIATOR	66 9456.D0 € 12,00 gr.07,4	66 9456.D0 € 12,00 gr.07,4	6613697.I0 € 18,00 gr.11	6613697.I0 € 18,00 gr.11
	VENTILVAR 2000 FIXED HALF-PULLEY	-	-	-	-
	VARIABLE-SPEED DRIVE ADJUSTER SPRING FOR VARIATOR	PG. 445 PG.445	PG.445	PG.445	PG.445
	TORSION CONTROLLER ANTIFRICTION FIFTH WHEEL	2513210 € 5,72	2513210 € 5,72	2513210 € 5,72	2513210 € 5,72
	TORQUE DRIVER MOBILE DRIVEN SPLIT PULLEY	6111656 € 123,88	6111656 € 123,88	6112563 2003-> € 197,30 6111656 <-2002 € 123,88	6112563 € 197,30
	OVER RANGE TRANSMISSION KIT	-	-	-	-
	MAXI FLY CLUTCH NOT ADJUSTABLE CLUTCH	-	-	-	-
	MAXI DELTA CLUTCH ADJUSTABLE CLUTCH	5211821 € 120,42	5211821 € 120,42	5211821 € 120,42	5211821 € 120,42
	MAXI CLUTCH BELL CLUTCH BELL (SMOOTH RING)	-	-	-	-
	MAXI WING CLUTCH BELL CLUTCH BELL (FINNED RING)	7715898B € 52,00 Ø 134	7715898B € 52,00 Ø 134	7715898B € 52,00 Ø 134	7715898B € 52,00 Ø 134
	MAXI FLY SYSTEM CLUTCH BELL + NOT ADJUSTABLE CLUTCH	-	-	-	-
	MAXI DELTA SYSTEM CLUTCH BELL + ADJUSTABLE CLUTCH	5216918 € 136,00 Ø 134	5216918 € 136,00 Ø 134	5216918 € 136,00 Ø 134	5216918 € 136,00 Ø 134
	SPRINGS FOR MAXI FLY CLUTCH	-	-	-	-
	SPRINGS FOR MAXI DELTA CLUTCH	2911326 € 17,00	2911326 € 17,00	2911326 € 17,00	2911326 € 17,00
	SPRINGS FOR ORIGINAL CLUTCH	2911326 € 17,00	2911326 € 17,00	2911326 € 17,00	2911326 € 17,00

01 - TO COUPLE ONLY with MALOSSI CYLINDERS: 3813273 € 475,00

16 - ATTENTION, ONLY for EURO 3 vehicles: 6115125 € 88,54

62 - TO COUPLE ONLY with MALOSSI CYLINDERS : 5911962 € 218,53

PG - SPECIFICATIONS on the PAGE indicated in the TITLE of the LINE

PIAGGIO

BEVERLY ie euro 3	BEVERLY S ie euro 3	BEVERLY ie euro 3 <-2009	BEVERLY ie euro 3 2010->	BEVERLY Sport Touring ie euro 3	BEVERLY ie euro 3	BEVERLY TOURER ie euro 3	BEVERLY ie euro 2-3
		(M28MM)	(M692M)	(M693M)	(M345M)	(M345M)	
250 4T LC	250 4T LC	300 4T LC	300 4T LC	350 4T LC	400 4T LC	400 4T LC	500 4T LC
3113928 €335,00 Ø 74	3113928 €335,00 Ø 74	3113958 €335,00 Ø 75,5	3113958 €335,00 Ø 75,5	-	-	-	-
-	-	-	-	-	-	-	-
-	-	-	-	-	5913846 €227,63	5913846 €227,63	5913846 €227,63
3813273 €475,00	3813273 €475,00	3813273 €475,00	3813273 €475,00	-	-	-	-
3113927 €745,00 Ø 74	3113927 €745,00 Ø 74	3114700 €745,00 Ø 75,5	3114700 €745,00 Ø 75,5	-	-	-	-
-	-	-	-	-	-	-	-
2714047 €118,53	2714047 €118,53	2714047 €118,53	2714047 €118,53	-	-	-	-
2912834 €21,54	2912834 €21,54	2912834 €21,54	2912834 €21,54	-	2913068 €22,74	2913068 €22,74	2913068 €22,74
-	-	-	-	-	-	-	-
-	-	-	-	-	-	-	-
-	-	-	-	-	-	-	-
5515724 €255,84	5515724 €255,84	5514780 €255,84	5514780 €255,84	5515723 €255,84	-	-	-
5514749 €84,00	5514749 €84,00	5514746 €90,00	5514746 €90,00	5514746 €90,00	-	-	-
5111885 €112,35	5111885 €112,35	5111885 €112,35	5111885 €112,35	5115308 €152,44	5114260 €173,04	5114260 €173,04	5114260 (8 rollers) €173,04 5111808 (6 rollers) €172,79
6116069 €60,00	6116069 €60,00	6116069 €60,00	6116069 €60,00	6115279 €72,32	6115125 €88,54	6115125 €88,54	*16*
6611095.TO €13,64 gr.15	6611095.TO €13,64 gr.15	6611095.TO €13,64 gr.15	6611095.TO €13,64 gr.15	6615452.IO €27,00 gr.10	6613554.B0 €26,00 gr.15	6613554.B0 €26,00 gr.15	6613554.B0 gr.15 (8) €26,00 6613968.A0 gr.20 (6) €17,81
6613697.IO €18,00 gr.11	6613697.IO €18,00 gr.11	-	-	6615452.CO €27,00 gr.16	6613554.CO €26,00 gr.16	6613554.CO €26,00 gr.16	6613968.B0 €17,81 gr.24 (6 rollers)
-	-	-	-	-	-	-	-
PG.445	PG.445	PG.445	PG.445	2915315.W0*PG* €15,97	PG.445	PG.445	PG.445
2513210 €5,72	2513210 €5,72	2513210 €5,72	2513210 €5,72	-	-	-	-
6112563 €197,30	6112563 €197,30	6112563 €197,30	6112563 €197,30	-	-	-	-
-	-	-	-	-	-	-	-
-	-	-	-	-	5212813 €146,14	5212813 €146,14	5212813 €146,14
5211821 €120,42	5211821 €120,42	5211821 €120,42	5211821 €120,42	-	-	-	-
-	-	-	-	-	-	-	-
7715898B €52,00 Ø 134	7715898B €52,00 Ø 134	7715898B €52,00 Ø 134	7715898B €52,00 Ø 134	-	7715579B €49,00 Ø 160	7715579B €49,00 Ø 160	7715579B €49,00 Ø 160
-	-	-	-	-	5216202 €149,94 Ø 160	5216202 €149,94 Ø 160	5216202 €149,94 Ø 160
5216918 €136,00 Ø 134	5216918 €136,00 Ø 134	5216918 €136,00 Ø 134	5216918 €136,00 Ø 134	-	-	-	-
-	-	-	-	-	2913137 €20,99	2913137 €20,99	2913137 €20,99
2911326 €17,00	2911326 €17,00	2911326 €17,00	2911326 €17,00	-	-	-	-
2911326 €17,00	2911326 €17,00	2911326 €17,00	2911326 €17,00	2915398 €19,90	2912779 €21,00	2912779 €21,00	2912779 (5 masses) €21,00 2911326 (3 masses) €15,94



MALOSSİ

Maxi Scooter

125 → 800 4T

with ENGINE 

PIAGGIO

BEVERLY
<-2009BEVERLY
ie euro 3
2010->

BEVERLY











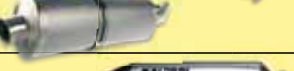



















BEVERLY
euro 1-2

(QUASAR)

(M285M)

CHECK "TYPE" SPECIFICATION (HOMOLOGATION MARK).

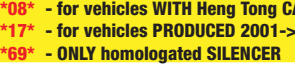
125 4T LC 125 4T LC 200 4T LC 250 4T LC

	CLUTCH DISK SET FOR ORIGINAL CLUTCH		-	-	-	-
	MAXI WILD LION  HOMOLOGATED EXHAUST SYSTEM		-	-	-	-
	RX  HOMOLOGATED EXHAUST SYSTEM		-	-	-	3214812 € 356,50
	RED CHILLI OIL OIL FILTER		0313382 € 7,00	0313382 € 7,00	0313382 € 7,00	0313382 € 7,00
	RED SPONGE FOR ORIGINAL AIR BOX		1412129 € 5,10	1412129 € 5,10	1412129 € 5,10	1412129 € 5,10
	DOUBLE RED SPONGE FOR ORIGINAL AIR BOX		1414496 € 7,35	1414496 € 7,35	1414496 € 7,35	1414496 € 7,35
	W BOX FOR ORIGINAL AIR BOX		-	-	-	-
	V FILTER VARIATOR AIR FILTER RIGHT SIDE		-	-	-	-
	POWER TRASMISSION		-	-	-	-
	GEARS HTQ PRIMARY		-	-	-	-
	GEARS HTQ SECONDARY		6712194 € 92,98 z 17/49	-	6712194 € 92,98 z 17/49	-
	SPORT SCREEN SCREEN		-	-	-	-
	MHR SCREEN SCREEN		-	-	-	-
	HOSE KIT FOR BRAKE		-	-	-	-
	BRAKE PADS FRONT ORGANIC BRAKE PADS		6215062 € 8,32	-	6215062 € 8,32	6215062 € 8,32
	BRAKE PADS MHR FRONT ORGANIC BRAKE PADS		6215079 € 8,20	-	6215079 € 8,20	6215079 € 8,20
	BRAKE PADS MHR SYNT FRONT SINTERED BRAKE PADS		6215013 *17* € 16,50	-	6215013 *17* € 16,50	6215013 € 16,50
	BRAKE PADS REAR ORGANIC BRAKE PADS		6215062 € 8,32	-	6215062 € 8,32	6215062 € 8,32
	BRAKE PADS MHR REAR ORGANIC BRAKE PADS		6215079 € 8,20	-	6215079 € 8,20	6215079 € 8,20
	BRAKE PADS MHR SYNT REAR SINTERED BRAKE PADS		6215013 *17* € 16,50	-	6215013 *17* € 16,50	6215013 € 16,50
	BRAKE POWER REAR BRAKE SHOES		-	-	-	-
	DISC / WHOOP DISC / PAIR WHOOP FRONT BRAKE DISC		6212352 € 95,83	-	6212352 € 95,83	6212352 € 95,83
	DISC / WHOOP DISC REAR BRAKE DISC		6212352 € 95,83	-	6212352 € 95,83	6212352 € 95,83
	TWINS MAXI SUSPENSIONS REAR PAIR SHOCK ABSORBER		4613183 € 232,00	4613183 € 232,00	4613183 € 232,00	4613183 € 232,00
	RS3 - RS1 REAR SHOCK ABSORBER		-	-	-	-
	RS24 REAR SHOCK ABSORBER		-	-	-	-
	RS24 FRONT SHOCK ABSORBER		-	-	-	-
	RS24 FRONT + REAR		-	-	-	-
	F32S FORK STEMS Ø 32		-	-	-	-
	F37R FORK STEMS Ø 37		-	-	-	-

07 - for vehicles WITH BREMBO CALIPER

08 - for vehicles WITH Heng Tong CALIPER

17 - for vehicles PRODUCED 2001-> with GRIMECA CALIPER: HOMOLOGATED, 6215011 € 16,00

69 - ONLY homologated SILENCER

PIAGGIO

BEVERLY ie euro 3		BEVERLY S ie euro 3		BEVERLY ie euro 3 <-2009		BEVERLY ie euro 3 2010->		BEVERLY Sport Touring ie euro 3		BEVERLY ie euro 3		BEVERLY TOURER ie euro 3		BEVERLY ie euro 2-3	
				(M28MM)		(M692M)		(M693M)		(M345M)		(M345M)			
250 4T	LC	250 4T	LC	300 4T	LC	300 4T	LC	350 4T	LC	400 4T	LC	400 4T	LC	500 4T	LC
-		-		-		-		5215609 € 65,00		-		-		-	
-		-		-		-		-		3214374 *69* € 476,34		3214374 *69* € 476,34		3214374 *69* € 476,34	
3214812 € 356,50		3214812 € 356,50		3214812 € 356,50		3214815 € 380,00		3215157 € 380,00		-		-		-	
0313382 € 7,00		0313382 € 7,00		0313382 € 7,00		0313382 € 7,00		-		0313383 € 7,42		0313383 € 7,42		0313383 € 7,42	
1412129 € 5,10		1412129 € 5,10		1412129 € 5,10		1412129 € 5,10		1415662 € 38,99		1412129 € 5,10		1412129 € 5,10		1412129 € 5,10	
1414496 € 7,35		1414496 € 7,35		1414496 € 7,35		1414496 € 7,35		-		1414496 € 7,35		1414496 € 7,35		1414496 € 7,35	
-		-		-		-		-		-		-		-	
-		-		-		-		-		-		-		-	
-		-		-		-		-		-		-		-	
-		-		-		-		-		-		-		-	
-		-		-		4516055 € 73,80		4516055 € 73,80		-		-		-	
-		-		-		-		-		-		-		-	
6215062 € 8,32		6215062 € 8,32		6215062 € 8,32		6215062 € 8,32		-		6215052 € 8,00 <-2007		6216896 € 9,50 2008->10		6216896 € 9,50	
6215079 € 8,20		6215079 € 8,20		6215079 € 8,20		6215079 € 8,20		-		6211525 € 8,20 <-2007		-		-	
6215013 € 16,50		6215013 € 16,50		6215013 € 16,50		6215013 € 16,50		-		6215020 € 16,00 <-2007		6215017 € 15,00 2008->10		6215017 € 15,00	
6215062 € 8,32		6215062 € 8,32		6215062 € 8,32		-		-		6215062 € 8,32 <-2007		6216418 *08* € 8,85 2008->10		6216418 *08* € 8,85	
6215079 € 8,20		6215079 € 8,20		6215079 € 8,20		-		-		6215079 € 8,20 <-2007		-		-	
6215013 € 16,50		6215013 € 16,50		6215013 € 16,50		-		-		6215013 € 16,50 <-2007		6215017 *07* € 15,00 2008->10		6215017 *07* € 15,00	
-		-		-		-		-		-		-		-	
6212352 € 95,83		6212352 € 95,83		6212352 € 95,83		-		-		6212352 € 95,83		-		6212352 € 95,83	
6212352 € 95,83		6212352 € 95,83		6212352 € 95,83		-		-		6212351 € 88,30		-		6212351 € 88,30	
4613183 € 232,00		4613183 € 232,00		4613183 € 232,00		4613183 € 232,00		-		4613179 € 245,00		4613179 € 245,00		4613179 € 245,00	
-		-		-		-		-		-		-		-	
-		-		-		-		-		-		-		-	
-		-		-		-		-		-		-		-	
-		-		-		-		-		-		-		-	
-		-		-		-		-		-		-		-	
-		-		-		-		-		-		-		-	

MAXI SCOOTER 125 → 800 4T



MALOSS

Maxi Scooter

125 → 800 4T

with ENGINE 

PIAGGIO

BEVERLY CRUISER
ie euro 3CARNABY
euro 3CARNABY
euro 3CARNABY
ie euro 3

(LEADER M28FM)

(LEADER M601M)

(QUASAR)

500 4T

LC

125 4T

LC

200 4T

LC

300 4T

LC

	CYLINDER 4 STROKE ALUMINIUM	-	3113955 € 335,00 Ø 75,5	3113955 € 335,00 Ø 75,5	3113958 € 335,00 Ø 75,5
	CYLINDER I-TECH ALUMINIUM EQUIPPED WITH CDI	-	-	-	-
	POWER CAM CAMSHAFT	5913846 € 227,63	*62*	5911962 € 218,53	-
	HEAD V4 HEAD FOR ORIGINAL CYLINDER / MALOSS	-	*01*	*01*	3813273 € 475,00
	CYLINDER + V4 HEAD ALUMINIUM	-	-	-	3114700 € 745,00 Ø 75,5
	CYLINDER + V4 HEAD + POWER CAM ALUMINIUM Ø 75,5	-	3116208 € 895,00	3116208 € 895,00	-
	4 STROKE VALVE FOR ENGINE VALVES SET	-	2714047 € 118,53	2714047 € 118,53	2714047 € 118,53
	SPRINGS FOR ENGINE VALVES	2913068 € 22,74	2912834 € 21,54	2912834 € 21,54	2912834 € 21,54
	CRANKSHAFT RHQ	-	5312853 € 380,00	5312896 € 380,00	-
	IGNITION CONTROLLER DIGITRONIC FOR VEHICLES WITHOUT IMMOBILIZER	-	5512524 € 170,46	5512524 € 170,46	-
	IGNITION CONTROLLER DIGITRONIC FOR VEHICLES WITH IMMOBILIZER	-	5512341 € 170,46	5512341 € 170,46	-
	FORCE MASTER INJECTION CONTROLLER	-	-	-	5514780 € 255,84
	TC UNIT O2 controller LAMBDA EMULATOR	-	-	-	5514746 € 90,00
	MULTIVAR 2000 VARIATOR MULTIVAR 2000 MHR	5114260 € 173,04	5111397 € 112,35	5111885 € 112,35	5111885 € 112,35
	X SPECIAL BELT BELT X K BELT BELT	6115125 € 88,54	6116118 € 35,00	6116697 € 67,00	6116697 € 67,00
	HTRoll ROLLERS FOR MULTIVAR 2000 / MHR	6613554.B0 € 26,00 gr.15	6611095.G0 € 13,64 gr.09,5	6611095.R0 € 13,64 gr.14	6611095.T0 € 13,64 gr.15
	HTRoll ROLLERS FOR ORIGINAL VARIATOR	-	66 9456.D0 € 12,00 gr.07,4	6613697.I0 € 18,00 gr.11	-
	VENTILVAR 2000 FIXED HALF-PULLEY	-	-	-	-
	VARIABLE-SPEED DRIVE ADJUSTER SPRING FOR VARIATOR	PG.445	PG.445	PG.445	PG.445
	TORSION CONTROLLER ANTIFRICTION FIFTH WHEEL	-	2513210 € 5,72	2513210 € 5,72	2513210 € 5,72
	TORQUE DRIVER MOBILE DRIVEN SPLIT PULLEY	-	6111656 € 123,88	6112563 € 197,30	6112563 € 197,30
	OVER RANGE TRANSMISSION KIT	-	-	-	-
	MAXI FLY CLUTCH NOT ADJUSTABLE CLUTCH	5212813 € 146,14	-	-	-
	MAXI DELTA CLUTCH ADJUSTABLE CLUTCH	-	5211821 € 120,42	5211821 € 120,42	5211821 € 120,42
	MAXI CLUTCH BELL CLUTCH BELL (SMOOTH RING)	-	-	-	-
	MAXI WING CLUTCH BELL CLUTCH BELL (FINNED RING)	7715579B € 49,00 Ø 160	7715898B € 52,00 Ø 134	7715898B € 52,00 Ø 134	7715898B € 52,00 Ø 134
	MAXI FLY SYSTEM CLUTCH BELL + NOT ADJUSTABLE CLUTCH	5216202 € 149,94 Ø 160	-	-	-
	MAXI DELTA SYSTEM CLUTCH BELL + ADJUSTABLE CLUTCH	-	5216918 € 136,00 Ø 134	5216918 € 136,00 Ø 134	5216918 € 136,00 Ø 134
	SPRINGS FOR MAXI FLY CLUTCH	2913137 € 20,99	-	-	-
	SPRINGS FOR MAXI DELTA CLUTCH	-	2911326 € 17,00	2911326 € 17,00	2911326 € 17,00
	SPRINGS FOR ORIGINAL CLUTCH	2912779 € 21,00	2911326 € 17,00	2911326 € 17,00	2911326 € 17,00

01 - TO COUPLE ONLY with MALOSS CYLINDERS: 3813273 € 475,00

10 - ATTENTION * ONLY FOR vehicles CIRCULATING in: INDONESIA - SINGAPORE - THAILAND - VIETNAM: 7715648 € 38,00

62 - TO COUPLE ONLY with MALOSS CYLINDERS : 5911962 € 218,53

PIAGGIO

FLY euro 2-3	NEW FLY 3V ie euro 3 2012->	FLY euro 2-3	HEXAGON LX4	SUPER HEXAGON GTX	SUPER HEXAGON GTX	HEXAGON	LIBERTY euro 0-1 <-1999
(LEADER M422M)		(LEADER M422M)					
125 4T	125 4T	150 4T	125 4T	125 4T	180 4T	250 4T	125 4T
3111393 €302,60 Ø 70	-	3111393 €302,60 Ø 70	31 9518 €295,92 Ø 60	3113955 €335,00 Ø 75,5	3113955 €335,00 Ø 75,5	-	31 9518 €295,92 Ø 60
-	3116669 €530,45 Ø 63	-	-	-	-	-	-
-	-	-	-	*62*	5911962 €218,53	-	-
-	-	-	-	*01*	*01*	-	-
-	-	-	-	-	-	-	-
-	-	-	-	3116208 €895,00	3116208 €895,00	-	-
-	-	-	-	2714047 €118,53	2714047 €118,53	-	-
-	-	-	-	2912834 €21,54	2912834 €21,54	-	-
-	-	-	-	5312853 €380,00	5312896 €380,00	-	-
-	-	-	-	5512524 €170,46	5512524 €170,46	-	-
-	-	-	-	5512341 €170,46	5512341 €170,46	-	-
-	-	-	-	-	-	-	-
-	5515735 €88,00	-	-	-	-	-	-
5111397 €112,35	5115639 €112,35	5111397 €112,35	5111154 €75,99	5111397 €112,35	5111594 €112,35	5113822 €119,13	5111154 €75,99
6116117 €34,27	6116117 €34,27	6116117 €34,27	-	6116117 €34,27	6115666 €46,92	61 9584 €39,82	-
6611095.G0 €13,64 gr.09,5	6611095.F0 €13,64 gr.09	6611095.R0 €13,64 gr.14	66 9420.K0 €10,00 gr.12	6611095.G0 €13,64 gr.09,5	6611095.R0 €13,64 gr.14	66 9917.C0 €19,12 gr.14	66 9420.K0 €10,00 gr.12
66 9456.F0 €12,00 gr.08,7	-	66 9456.H0 €12,00 gr.10	-	66 9456.D0 €12,00 gr.07,4	-	66 9915.D0 €17,80 gr.23	6611531.H0 €9,41 gr.12
-	-	-	-	-	-	-	-
PG.445	PG.445	PG.445	-	PG.445	PG.445	-	-
2513210 €5,72	2513210 €5,72	2513210 €5,72	-	2513210 €5,72	2513210 €5,72	-	-
6111656 €123,88	-	6111656 €123,88	-	6111656 €123,88	6111656 €123,88	-	-
-	-	-	-	-	-	-	-
-	-	-	-	-	-	-	-
5211821 €120,42	5216462 €120,42	5211821 €120,42	-	5211821 €120,42	5211821 €120,42	-	-
-	7715647 *10* €43,00 Ø 134	-	-	-	-	-	-
7715898B €52,00 Ø 134	-	7715898B €52,00 Ø 134	-	7715898B €52,00 Ø 134	7715898B €52,00 Ø 134	-	-
-	-	-	-	-	-	-	-
5216918 €136,00 Ø 134	5216569 €135,00 Ø 134	5216918 €136,00 Ø 134	-	5216918 €136,00 Ø 134	5216918 €136,00 Ø 134	-	-
-	-	-	-	-	-	-	-
2911326 €17,00	-	2911326 €17,00	-	2911326 €17,00	-	-	-
2911326 €17,00	2911326 €17,00	2911326 €17,00	-	2911326 €17,00	2911326 €17,00	2911326 €17,00	-



MALOSSI

Maxi Scooter

125 → 800 4T











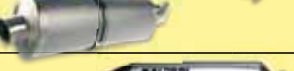





















with ENGINE **PIAGGIO**BEVERLY CRUISER
ie euro 3CARNABY
euro 3CARNABY
euro 3CARNABY
ie euro 3

(LEADER M28FM)

(LEADER M601M)

(QUASAR)

() CHECK "TYPE" SPECIFICATION (HOMOLOGATION MARK).500 4T **LC** 125 4T **LC** 200 4T **LC** 300 4T **LC**

	CLUTCH DISK SET FOR ORIGINAL CLUTCH		-	-	-	-
	MAXI WILD LION   HOMOLOGATED EXHAUST SYSTEM		3214374 *69* € 476,34	-	-	-
	RX   HOMOLOGATED EXHAUST SYSTEM		-	-	-	3214818 € 339,50
	RED CHILLI OIL OIL FILTER		0313383 € 7,42	0313382 € 7,00	0313382 € 7,00	0313382 € 7,00
	RED SPONGE FOR ORIGINAL AIR BOX		1412129 € 5,10	1412129 € 5,10	1412129 € 5,10	1412129 € 5,10
	DOUBLE RED SPONGE FOR ORIGINAL AIR BOX		1414496 € 7,35	1414496 € 7,35	1414496 € 7,35	1414496 € 7,35
	W BOX FOR ORIGINAL AIR BOX		-	-	-	-
	V FILTER VARIATOR AIR FILTER RIGHT SIDE		-	-	-	-
	POWER TRASMISSION		-	-	-	-
	GEARS HTQ PRIMARY		-	-	-	-
	GEARS HTQ SECONDARY		-	6712194 € 92,98 z 17/49	-	-
	SPORT SCREEN SCREEN		-	-	-	-
	MHR SCREEN SCREEN		-	-	-	-
	HOSE KIT FOR BRAKE		-	-	-	-
	BRAKE PADS FRONT ORGANIC BRAKE PADS		6216896 € 9,50	6215062 € 8,32	6215062 € 8,32	6215062 € 8,32
	BRAKE PADS MHR FRONT ORGANIC BRAKE PADS		-	6215079 € 8,20	6215079 € 8,20	6215079 € 8,20
	BRAKE PADS MHR SYNT FRONT SINTERED BRAKE PADS		6215017 € 15,00	6215013 € 16,50	6215013 € 16,50	6215013 € 16,50
	BRAKE PADS REAR ORGANIC BRAKE PADS		6216418 *08* € 8,85	6215062 € 8,32	6215062 € 8,32	6215062 € 8,32
	BRAKE PADS MHR REAR ORGANIC BRAKE PADS		-	6215079 € 8,20	6215079 € 8,20	6215079 € 8,20
	BRAKE PADS MHR SYNT REAR SINTERED BRAKE PADS		6215017 *07* € 15,00	6215013 € 16,50	6215013 € 16,50	6215013 € 16,50
	BRAKE POWER REAR BRAKE SHOES		-	-	-	-
	DISC / WHOOP DISC / PAIR WHOOP FRONT BRAKE DISC		6212352 € 95,83	6212352 € 95,83	6212352 € 95,83	6212352 € 95,83
	DISC / WHOOP DISC REAR BRAKE DISC		6212351 € 88,30	6212352 € 95,83	6212352 € 95,83	6212352 € 95,83
	TWINS MAXI SUSPENSIONS REAR PAIR SHOCK ABSORBER		-	4613183 € 232,00	4613183 € 232,00	4613183 € 232,00
	RS3 - RS1 REAR SHOCK ABSORBER		-	-	-	-
	RS24 REAR SHOCK ABSORBER		-	-	-	-
	RS24 FRONT SHOCK ABSORBER		-	-	-	-
	RS24 FRONT + REAR		-	-	-	-
	F32S FORK STEMS Ø 32		-	-	-	-
	F37R FORK STEMS Ø 37		-	-	-	-

07 - for vehicles WITH BREMBO CALIPER

08 - for vehicles WITH Heng Tong CALIPER

69 - ONLY homologated SILENCER

PIAGGIO

FLY euro 2-3	NEW FLY 3V ie euro 3 2012->	FLY euro 2-3	HEXAGON LX4	SUPER HEXAGON GTX	SUPER HEXAGON GTX	HEXAGON	LIBERTY euro 0-1 <-1999
(LEADER M422M)		(LEADER M422M)					
125 4T	125 4T	150 4T	125 4T	125 4T	180 4T LC	250 4T LC	125 4T
-	-	-	-	-	-	-	-
-	-	-	-	-	-	-	-
-	-	-	-	-	-	-	-
0313382 € 7,00	0313382 € 7,00	0313382 € 7,00	0313381 € 3,80	0313382 € 7,00	0313382 € 7,00	-	0313381 € 3,80
-	1416571 € 3,90	-	-	-	-	-	1411425 € 4,45
1414532 € 6,70	-	1414532 € 6,70	-	-	-	-	1414503 € 6,65
-	-	-	-	-	-	-	-
-	-	-	-	-	-	-	-
-	-	-	-	-	-	-	-
-	-	-	-	-	-	-	-
6712067 € 69,96 z 15/41	-	6712067 € 69,96 z 15/41	-	6711860 € 60,41 z 16/42	6711860 € 60,41 z 16/42	-	6711445 € 56,36 z 15/47
-	-	-	-	-	-	-	-
-	-	-	-	-	-	-	-
6215062 € 8,32	6215062 € 8,32	6215062 € 8,32	-	-	-	-	6215049 € 6,24 1998->
6215079 € 8,20	6215079 € 8,20	6215079 € 8,20	-	-	-	-	6215074 € 6,30 1998->
6215013 € 16,50	6215013 € 16,50	6215013 € 16,50	-	6215011 € 16,00 <-2000	6215011 € 16,00 <-2000	-	6215006 € 11,96 1998->
-	-	-	-	6215049 € 6,24 <-2000	6215049 € 6,24 <-2000	-	-
-	-	-	-	6215074 € 6,30 <-2000	6215074 € 6,30 <-2000	-	-
-	6215015 € 16,64	-	-	6215015 2001-> € 16,64 6215006 <-2000 € 11,96	6215015 2001-> € 16,64 6215006 <-2000 € 11,96	-	-
-	-	-	-	-	-	-	6215328 € 18,39 1998->
6212604 € 76,38	-	6212604 € 76,38	6212604 € 76,38	-	-	-	-
-	-	-	-	-	-	-	-
-	-	-	-	-	-	-	4613315 € 144,00 INDIVIDUAL
-	-	-	-	-	-	-	46 7908 € 140,92 4615432 € 94,86
-	-	-	-	-	-	-	46 8308 € 248,50
-	-	-	-	-	-	-	-
-	-	-	-	-	-	-	-
-	-	-	-	-	-	-	-

MAXI SCOOTER 125 → 800 4T



MALOSSI

Maxi Scooter

125 → 800 4T

with ENGINE 

PIAGGIO

LIBERTY -
LIBERTY LE
euro 1-2LIBERTY
euro 3LIBERTY S
euro 3LIBERTY 3V
ie euro 3

(LEADER)

(LEADER M389M)

(LEADER M381M)

125 4T



125 4T



125 4T



125 4T



	CYLINDER 4 STROKE ALUMINIUM	3111393 €302,60 Ø 70	3111393 €302,60 Ø 70	3111393 €302,60 Ø 70	-
	CYLINDER I-TECH ALUMINIUM EQUIPPED WITH CDI	-	-	-	*TEC2*
	POWER CAM CAMSHAFT	-	-	-	-
	HEAD V4 HEAD FOR ORIGINAL CYLINDER / MALOSSI	-	-	-	-
	CYLINDER + V4 HEAD ALUMINIUM	-	-	-	-
	CYLINDER + V4 HEAD + POWER CAM ALUMINIUM Ø 75,5	-	-	-	-
	4 STROKE VALVE FOR ENGINE VALVES SET	-	-	-	-
	SPRINGS FOR ENGINE VALVES	-	-	-	-
	CRANKSHAFT RHQ	-	-	-	-
	IGNITION CONTROLLER DIGITRONIC FOR VEHICLES WITHOUT IMMOBILIZER	-	-	-	-
	IGNITION CONTROLLER DIGITRONIC FOR VEHICLES WITH IMMOBILIZER	-	-	-	-
	FORCE MASTER INJECTION CONTROLLER	-	-	-	-
	TC UNIT O2 controller LAMBDA EMULATOR	-	-	-	5515735 €88,00
	MULTIVAR 2000 VARIATOR MULTIVAR 2000 MHR	5111397 €112,35	5111397 €112,35	5111397 €112,35	5116149 €112,35
	X SPECIAL BELT BELT X K BELT BELT	6116117 €34,27	6116117 €34,27	6116117 €34,27	6116148 €31,00
	HTRoII ROLLERS FOR MULTIVAR 2000 / MHR	6611095.G0 €13,64 gr.09,5	6611095.G0 €13,64 gr.09,5	6611095.G0 €13,64 gr.09,5	6611095.H0 €13,64 gr.10
	HTRoII ROLLERS FOR ORIGINAL VARIATOR	66 9456.F0 €12,00 gr.08,7	66 9456.F0 €12,00 gr.08,7	66 9456.F0 €12,00 gr.08,7	-
	VENTILVAR 2000 FIXED HALF-PULLEY	-	-	-	-
	VARIABLE-SPEED DRIVE ADJUSTER SPRING FOR VARIATOR	PG.445	PG.445	PG.445	*71*
	TORSION CONTROLLER ANTIFRICTION FIFTH WHEEL	2513210 €5,72	2513210 €5,72	2513210 €5,72	-
	TORQUE DRIVER MOBILE DRIVEN SPLIT PULLEY	6111656 €123,88	6111656 €123,88	6111656 €123,88	-
	OVER RANGE TRANSMISSION KIT	-	-	-	-
	MAXI FLY CLUTCH NOT ADJUSTABLE CLUTCH	-	-	-	-
	MAXI DELTA CLUTCH ADJUSTABLE CLUTCH	5211821 €120,42	5211821 €120,42	5211821 €120,42	-
	MAXI CLUTCH BELL CLUTCH BELL (SMOOTH RING)	-	-	-	7715648 €38,00 Ø 125
	MAXI WING CLUTCH BELL CLUTCH BELL (FINNED RING)	7715898B €52,00 Ø 134	7715898B €52,00 Ø 134	7715898B €52,00 Ø 134	-
	MAXI FLY SYSTEM CLUTCH BELL + NOT ADJUSTABLE CLUTCH	-	-	-	-
	MAXI DELTA SYSTEM CLUTCH BELL + ADJUSTABLE CLUTCH	5216918 €136,00 Ø 134	5216918 €136,00 Ø 134	5216918 €136,00 Ø 134	-
	SPRINGS FOR MAXI FLY CLUTCH	-	-	-	-
	SPRINGS FOR MAXI DELTA CLUTCH	2911326 €17,00	2911326 €17,00	2911326 €17,00	-
	SPRINGS FOR ORIGINAL CLUTCH	2911326 €17,00	2911326 €17,00	2911326 €17,00	2912536 €15,56

01 - TO COUPLE ONLY with MALOSSI CYLINDERS: 3813273 € 475,00

62 - TO COUPLE ONLY with MALOSSI CYLINDERS : 5911962 € 218,53

71 - For vehicles WITH pulley with LATERAL HOOKS "N°.", "1" - 29 8360.W0 € 6,50 / "2" - 29 7046.R0 € 5,91

TEC1 ** ATTENTION ** PLEASE CHECK THE PROPER FITMENT : PAGE 416

PIAGGIO

LIBERTY - LIBERTY LE euro 1-2	LIBERTY euro 3	LIBERTY 3V ie euro 3	LIBERTY - LIBERTY S euro 3	MP3 euro 3	MP3 YOURBAN 4V ie euro 3 2011->	MP3 ie euro 3	MP3 ie euro 3
(LEADER)	(LEADER M672M)	(M738M)	(LEADER)	(LEADER)		(QUASAR M472M)	(QUASAR M634M)
150 4T	150 4T	150 4T	200 4T	125 4T	125 4T	250 4T	300 4T
				LC	LC	LC	LC
3111393 €302,60 Ø 70	3111393 €302,60 Ø 70	-	-	3113955 €335,00 Ø 75,5	-	3113928 €335,00 Ø 74	3113958 €335,00 Ø 75,5
-	-	*TEC2*	-	-	3116090 €520,00 Ø 75,5	-	-
-	-	-	-	*62*	*TEC1*	-	-
-	-	-	-	*01*	*TEC1*	3813273 €475,00	3813273 €475,00
-	-	-	-	-	-	3113927 €745,00 Ø 74	3114700 €745,00 Ø 75,5
-	-	-	-	3116208 €895,00	*TEC1*	-	-
-	-	-	-	2714047 €118,53	-	2714047 €118,53	2714047 €118,53
-	-	-	-	2912834 €21,54	2912834 €21,54	2912834 €21,54	2912834 €21,54
-	-	-	-	5312853 €380,00	-	-	-
-	-	-	-	-	-	-	-
-	-	-	-	-	-	-	-
-	-	-	-	-	-	5515724 €255,84	5514780 €255,84
-	-	5515735 €88,00	-	-	5514746 €90,00	5514749 €84,00	5514746 €90,00
5111397 €112,35	5111397 €112,35	5115639 €112,35	5111885 €112,35	5111397 €112,35	5111397 €112,35	5111885 €112,35	5111885 €112,35
6116117 €34,27	6116117 €34,27	6116117 €34,27	6115666 €46,92	6116117 €34,27	6116118 €35,00	6113027 €59,12	6113027 €59,12
6611095.R0 €13,64 gr.14	6611095.R0 €13,64 gr.14	6611095.Q0 €13,64 gr.13,5	6611095.R0 €13,64 gr.14	6611095.G0 €13,64 gr.09,5	6611095.G0 €13,64 gr.09,5	6611095.T0 €13,64 gr.15	6611095.T0 €13,64 gr.15
66 9456.H0 €12,00 gr.10	66 9456.H0 €12,00 gr.10	-	6613697.I0 €18,00 gr.11	66 9456.D0 €12,00 gr.07,4	66 9456.D0 €12,00 gr.07,4	6613697.I0 €18,00 gr.11	-
-	-	-	-	-	-	-	-
PG.445	PG.445	PG.445	PG.445	PG.445	PG.445	PG.445	PG.445
2513210 €5,72	2513210 €5,72	2513210 €5,72	2513210 €5,72	2513210 €5,72	2513210 €5,72	2513210 €5,72	2513210 €5,72
6111656 €123,88	6111656 €123,88	-	6111656 €123,88	6111656 €123,88	6111656 €123,88	6112563 €197,30	6112563 €197,30
-	-	-	-	-	-	-	-
-	-	-	-	-	-	-	-
5211821 €120,42	5211821 €120,42	5216462 €120,42	5211821 €120,42	5211821 €120,42	5211821 €120,42	5211821 €120,42	5211821 €120,42
-	-	7715647 €43,00 Ø 134	-	-	-	-	-
7715898B €52,00 Ø 134	7715898B €52,00 Ø 134	-	7715898B €52,00 Ø 134	7715898B €52,00 Ø 134	7715898B €52,00 Ø 134	7715898B €52,00 Ø 134	7715898B €52,00 Ø 134
-	-	-	-	-	-	-	-
5216918 €136,00 Ø 134	5216918 €136,00 Ø 134	5216569 €135,00 Ø 134	5216918 €136,00 Ø 134	5216918 €136,00 Ø 134	5216918 €136,00 Ø 134	5216918 €136,00 Ø 134	5216918 €136,00 Ø 134
-	-	-	-	-	-	-	-
2911326 €17,00	2911326 €17,00	-	2911326 €17,00	2911326 €17,00	2911326 €17,00	2911326 €17,00	2911326 €17,00
2911326 €17,00	2911326 €17,00	2911326 €17,00	2911326 €17,00	2911326 €17,00	2911326 €17,00	2911326 €17,00	2911326 €17,00

MAXI SCOOTER 125 → 800 4T



MALOSSI

Maxi Scooter

125 → 800 4T

with ENGINE **PIAGGIO**LIBERTY -
LIBERTY LE
euro 1-2LIBERTY
euro 3LIBERTY S
euro 3LIBERTY 3V
ie euro 3

(LEADER)

(LEADER M389M)

(LEADER M381M)

125 4T



125 4T











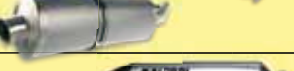



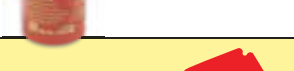

















125 4T



125 4T





**() CHECK "TYPE" SPECIFICATION (HOMOLOGATION MARK).**

	CLUTCH DISK SET FOR ORIGINAL CLUTCH		-	-	-	-
	MAXI WILD LION () HOMOLOGATED EXHAUST SYSTEM		-	-	-	-
	RX () HOMOLOGATED EXHAUST SYSTEM		-	-	-	-
	RED CHILLI OIL OIL FILTER		0313382 € 7,00	0313382 € 7,00	0313382 € 7,00	0313382 € 7,00
	RED SPONGE FOR ORIGINAL AIR BOX		-	-	-	1416571 € 3,90
	DOUBLE RED SPONGE FOR ORIGINAL AIR BOX		1414532 € 6,70	1414532 € 6,70	1414532 € 6,70	-
	W BOX FOR ORIGINAL AIR BOX		-	-	-	-
	V FILTER VARIATOR AIR FILTER RIGHT SIDE		-	-	-	-
	POWER TRASMISSION		-	-	-	-
	GEARS HTQ PRIMARY		-	-	-	-
	GEARS HTQ SECONDARY		6712067 € 69,96 z 15/41	6712067 € 69,96 z 15/41	6712067 € 69,96 z 15/41	6712067 € 69,96 z 15/41
	SPORT SCREEN SCREEN		-	-	-	-
	MHR SCREEN SCREEN		-	-	-	-
	HOSE KIT FOR BRAKE		-	-	-	-
	BRAKE PADS FRONT ORGANIC BRAKE PADS		6215049 € 6,24 2000->	6215062 € 8,32	6215049 € 6,24 2000->	6215062 € 8,32
	BRAKE PADS MHR FRONT ORGANIC BRAKE PADS		6215074 € 6,30 2000->	6215079 € 8,20	6215074 € 6,30 2000->	6215079 € 8,20
	BRAKE PADS MHR SYNT FRONT SINTERED BRAKE PADS		6215006 € 11,96 2000->	6215013 € 16,50	6215006 € 11,96 2000->	6215013 € 16,50
	BRAKE PADS REAR ORGANIC BRAKE PADS		-	-	-	-
	BRAKE PADS MHR REAR ORGANIC BRAKE PADS		-	-	-	-
	BRAKE PADS MHR SYNT REAR SINTERED BRAKE PADS		-	-	-	-
	BRAKE POWER REAR BRAKE SHOES		-	-	-	-
	DISC / WHOOP DISC / PAIR WHOOP FRONT BRAKE DISC		-	6212351 € 88,30	-	6212351 € 88,30
	DISC / WHOOP DISC REAR BRAKE DISC		-	-	-	-
	TWINS MAXI SUSPENSIONS REAR PAIR SHOCK ABSORBER		4613315 € 144,00 INDIVIDUAL	4613315 € 144,00 INDIVIDUAL	4613315 € 144,00 INDIVIDUAL	4613315 € 144,00 INDIVIDUAL
	RS3 - RS1 REAR SHOCK ABSORBER		-	-	-	-
	RS24 REAR SHOCK ABSORBER		-	-	-	-
	RS24 FRONT SHOCK ABSORBER		-	-	-	-
	RS24 FRONT + REAR		-	-	-	-
	F32S FORK STEMS Ø 32		-	-	-	-
	F37R FORK STEMS Ø 37		-	-	-	-

08 - for vehicles WITH Heng Tong CALIPER

09 - for vehicles PRODUCED 2006->08 with Heng Tong CALIPER: 6216418 € 8,85

PIAGGIO

LIBERTY - LIBERTY LE euro 1-2	LIBERTY euro 3	LIBERTY 3V ie euro 3	LIBERTY - LIBERTY S euro 3	MP3 euro 3	MP3 YOURBAN 4V ie euro 3 2011->	MP3 ie euro 3	MP3 ie euro 3
(LEADER)	(LEADER M672M)	(M738M)	(LEADER)	(LEADER)		(QUASAR M472M)	(QUASAR M634M)
150 4T 	150 4T 	150 4T 	200 4T 	125 4T LC	125 4T LC	250 4T LC	300 4T LC
-	-	-	-	-	-	-	-
-	-	-	-	-	-	-	-
-	-	-	-	-	3214821 € 339,50	-	-
0313382 € 7,00	0313382 € 7,00	0313382 € 7,00	0313382 € 7,00	0313382 € 7,00	0313382 € 7,00	0313382 € 7,00	0313382 € 7,00
-	-	1416571 € 3,90	-	1413811 € 5,84	1412129 € 5,10	-	-
1414532 € 6,70	1414532 € 6,70	-	1414532 € 6,70	1414486 € 7,02	1414496 € 7,35	-	-
-	-	-	-	-	-	-	-
-	-	-	-	-	-	-	-
-	-	-	-	-	-	-	-
6712067 € 69,96 z 15/41	6712067 € 69,96 z 15/41	6712067 € 69,96 z 15/41	-	6712067 € 69,96 z 15/41	-	-	-
-	-	-	-	-	-	-	-
-	-	-	-	-	-	-	-
6215049 € 6,24 2000->	6215062 € 8,32	6215062 € 8,32	6215049 € 6,24	6215049 € 6,24	-	6215049 € 6,24	6215049 € 6,24
6215074 € 6,30 2000->	6215079 € 8,20	6215079 € 8,20	6215074 € 6,30	6215074 € 6,30	-	6215074 € 6,30	6215074 € 6,30
6215006 € 11,96 2000->	6215013 € 16,50	6215013 € 16,50	6215006 € 11,96	6215006 € 11,96	-	6215006 € 11,96	6215006 € 11,96
-	-	-	-	6215062 *09* € 8,32 2009->	-	6216418 *08* € 8,85 2006->08	-
-	-	-	-	6215079 € 8,20	-	-	-
-	-	-	-	6215013 € 16,50	-	-	-
-	-	-	-	-	-	-	-
-	-	6212351 € 88,30	-	-	-	-	-
-	-	-	-	6212351 € 88,30	-	6212351 € 88,30	6212351 € 88,30
4613315 € 144,00 INDIVIDUAL	4613315 € 144,00 INDIVIDUAL	4613315 € 144,00 INDIVIDUAL	4613315 € 144,00 INDIVIDUAL	4614789 € 261,00	-	-	-
-	-	-	-	-	-	-	-
-	-	-	-	-	-	-	-
-	-	-	-	-	-	-	-
-	-	-	-	-	-	-	-
-	-	-	-	-	-	-	-
-	-	-	-	-	-	-	-

MAXI SCOOTER 125 → 800 4T



MALOSSI

Maxi Scooter

125 → 800 4T

with ENGINE **PIAGGIO**MP3
ie euro 3
2014->MP3 YOURBAN 4V
ie euro 3
2011->MP3
ie euro 3MP3
ie euro 3

(M862M)

(MASTER M474M)

300 4T **LC**300 4T **LC**400 4T **LC**500 4T **LC**

	CYLINDER 4 STROKE ALUMINIUM	3113958 € 335,00 Ø 75,5	3113958 € 335,00 Ø 75,5	-	-
	CYLINDER I-TECH ALUMINIUM EQUIPPED WITH CDI	-	-	-	-
	POWER CAM CAMSHAFT	-	-	5913846 € 227,63	5913846 € 227,63
	HEAD V4 HEAD FOR ORIGINAL CYLINDER / MALOSSI	3813273 € 475,00	3813273 € 475,00	-	-
	CYLINDER + V4 HEAD ALUMINIUM	3114700 € 745,00 Ø 75,5	3114700 € 745,00 Ø 75,5	-	-
	CYLINDER + V4 HEAD + POWER CAM ALUMINIUM Ø 75,5	-	-	-	-
	4 STROKE VALVE FOR ENGINE VALVES SET	2714047 € 118,53	2714047 € 118,53	-	-
	SPRINGS FOR ENGINE VALVES	2912834 € 21,54	2912834 € 21,54	2913068 € 22,74	2913068 € 22,74
	CRANKSHAFT RHQ	-	-	-	-
	IGNITION CONTROLLER DIGITRONIC FOR VEHICLES WITHOUT IMMOBILIZER	-	-	-	-
	IGNITION CONTROLLER DIGITRONIC FOR VEHICLES WITH IMMOBILIZER	-	-	-	-
	FORCE MASTER INJECTION CONTROLLER	5514780 € 255,84	5514780 € 255,84	-	-
	TC UNIT O2 controller LAMBDA EMULATOR	5514746 € 90,00	-	5514746 € 90,00	-
	MULTIVAR 2000 VARIATOR MULTIVAR 2000 MHR	5111885 € 112,35	5111885 € 112,35	5114260 € 173,04	5114260 € 173,04
	X SPECIAL BELT BELT X K BELT BELT	6113027 € 59,12	6113027 € 59,12	6115125 € 88,54	6115125 € 88,54
	HTRoll ROLLERS FOR MULTIVAR 2000 / MHR	6611095.TO € 13,64 gr.15	6611095.TO € 13,64 gr.15	6613554.B0 € 26,00 gr.15	6613554.B0 € 26,00 gr.15
	HTRoll ROLLERS FOR ORIGINAL VARIATOR	-	-	-	-
	VENTILVAR 2000 FIXED HALF-PULLEY	-	-	-	-
	VARIABLE-SPEED DRIVE ADJUSTER SPRING FOR VARIATOR	PG.445	PG.445	PG.445	PG.445
	TORSION CONTROLLER ANTIFRICTION FIFTH WHEEL	2513210 € 5,72	2513210 € 5,72	-	-
	TORQUE DRIVER MOBILE DRIVEN SPLIT PULLEY	6112563 € 197,30	6112563 € 197,30	-	-
	OVER RANGE TRANSMISSION KIT	-	-	-	-
	MAXI FLY CLUTCH NOT ADJUSTABLE CLUTCH	-	-	5212813 € 146,14	5212813 € 146,14
	MAXI DELTA CLUTCH ADJUSTABLE CLUTCH	5211821 € 120,42	5211821 € 120,42	-	-
	MAXI CLUTCH BELL CLUTCH BELL (SMOOTH RING)	-	-	-	-
	MAXI WING CLUTCH BELL CLUTCH BELL (FINNED RING)	7715898B € 52,00 Ø 134	7715898B € 52,00 Ø 134	7715579B € 49,00 Ø 160	7715579B € 49,00 Ø 160
	MAXI FLY SYSTEM CLUTCH BELL + NOT ADJUSTABLE CLUTCH	-	-	5216202 € 149,94 Ø 160	5216202 € 149,94 Ø 160
	MAXI DELTA SYSTEM CLUTCH BELL + ADJUSTABLE CLUTCH	5216918 € 136,00 Ø 134	5216918 € 136,00 Ø 134	-	-
	SPRINGS FOR MAXI FLY CLUTCH	-	-	2913137 € 20,99	2913137 € 20,99
	SPRINGS FOR MAXI DELTA CLUTCH	2911326 € 17,00	2911326 € 17,00	-	-
	SPRINGS FOR ORIGINAL CLUTCH	2911326 € 17,00	2911326 € 17,00	2912779 € 21,00	2912779 € 21,00

01 - TO COUPLE ONLY with MALOSSI CYLINDERS: 3813273 € 475,00

62 - TO COUPLE ONLY with MALOSSI CYLINDERS : 5911962 € 218,53

TEC1 ** ATTENTION ** PLEASE CHECK THE PROPER FITMENT : PAGE 416

PIAGGIO

SKIPPER ST	SKIPPER ST	TYPHOON euro 3	X7 euro 3	X7 EVO ie euro 3	X7 ie euro 3	X7 EVO ie euro 3	X8 euro 2-3
(LEADER)	(LEADER)	(LEADER M701M)	(LEADER)	(QUASAR)	(QUASAR M622M)	(QUASAR)	(LEADER)
125 4T	150 4T	125 4T	125 4T LC	125 4T LC	250 4T LC	300 4T LC	125 4T LC
3111393 € 302,60 Ø 70	3111393 € 302,60 Ø 70	3111393 € 302,60 Ø 70	3113955 € 335,00 Ø 75,5	-	3113928 € 335,00 Ø 74	3113958 € 335,00 Ø 75,5	3113955 € 335,00 Ø 75,5
-	-	-	-	3116090 € 520,00 Ø 75,5	-	-	-
-	-	-	*62*	*TEC1*	-	-	*62*
-	-	-	*01*	*TEC1*	3813273 € 475,00	3813273 € 475,00	*01*
-	-	-	-	-	3113927 € 745,00 Ø 74	3114700 € 745,00 Ø 75,5	-
-	-	-	3116208 € 895,00	*TEC1*	-	-	3116208 € 895,00
-	-	-	2714047 € 118,53	2714047 € 118,53	2714047 € 118,53	2714047 € 118,53	2714047 € 118,53
-	-	-	2912834 € 21,54	2912834 € 21,54	2912834 € 21,54	2912834 € 21,54	2912834 € 21,54
-	-	-	5312853 € 380,00	-	-	-	5312853 € 380,00
-	-	-	5512524 € 170,46	-	-	-	5512524 € 170,46
-	-	-	5512341 € 170,46	-	-	-	5512341 € 170,46
-	-	-	-	-	5515724 € 255,84	5514780 € 255,84	-
-	-	-	-	5514746 € 90,00	5514749 € 84,00	5514749 € 84,00	-
5111397 € 112,35	5111397 € 112,35	5111397 € 112,35	5111397 € 112,35	5111397 € 112,35	5111885 € 112,35	5111885 € 112,35	5111397 € 112,35
6116117 € 34,27	6116117 € 34,27	6116117 € 34,27	6116117 € 34,27	6116117 € 34,27	6113027 € 59,12	6113027 € 59,12	6116117 € 34,27
6611095.G0 € 13,64 gr.09,5	6611095.R0 € 13,64 gr.14	6611095.G0 € 13,64 gr.09,5	6611095.G0 € 13,64 gr.09,5	6611095.G0 € 13,64 gr.09,5	6611095.T0 € 13,64 gr.15	6611095.T0 € 13,64 gr.15	6611095.G0 € 13,64 gr.09,5
66 9456.F0 € 12,00 gr.08,7	66 9456.H0 € 12,00 gr.10	66 9456.F0 € 12,00 gr.08,7	66 9456.D0 € 12,00 gr.07,4	66 9456.D0 € 12,00 gr.07,4	6613697.I0 € 18,00 gr.11	6613697.I0 € 18,00 gr.11	66 9456.D0 € 12,00 gr.07,4
-	-	-	-	-	-	-	-
PG.445	PG.445	PG.445	PG.445	PG.445	PG.445	PG.445	PG.445
2513210 € 5,72	2513210 € 5,72	2513210 € 5,72	2513210 € 5,72	2513210 € 5,72	2513210 € 5,72	2513210 € 5,72	2513210 € 5,72
6111656 € 123,88	6111656 € 123,88	6111656 € 123,88	6111656 € 123,88	6111656 € 123,88	6112563 € 197,30	6112563 € 197,30	6111656 € 123,88
-	-	-	-	-	-	-	-
-	-	-	-	-	-	-	-
5211821 € 120,42	5211821 € 120,42	5211821 € 120,42	5211821 € 120,42	5211821 € 120,42	5211821 € 120,42	5211821 € 120,42	5211821 € 120,42
-	-	-	-	-	-	-	-
7715898B € 52,00 Ø 134	7715898B € 52,00 Ø 134	7715898B € 52,00 Ø 134	7715898B € 52,00 Ø 134	7715898B € 52,00 Ø 134	7715898B € 52,00 Ø 134	7715898B € 52,00 Ø 134	7715898B € 52,00 Ø 134
-	-	-	-	-	-	-	-
5216918 € 136,00 Ø 134	5216918 € 136,00 Ø 134	5216918 € 136,00 Ø 134	5216918 € 136,00 Ø 134	5216918 € 136,00 Ø 134	5216918 € 136,00 Ø 134	5216918 € 136,00 Ø 134	5216918 € 136,00 Ø 134
-	-	-	-	-	-	-	-
2911326 € 17,00	2911326 € 17,00	2911326 € 17,00	2911326 € 17,00	2911326 € 17,00	2911326 € 17,00	2911326 € 17,00	2911326 € 17,00
2911326 € 17,00	2911326 € 17,00	2913137 € 20,99	2911326 € 17,00	2911326 € 17,00	2911326 € 17,00	2911326 € 17,00	2911326 € 17,00



MALOSSİ

Maxi Scooter

125 → 800 4T

with ENGINE 





























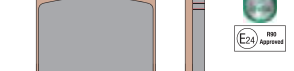

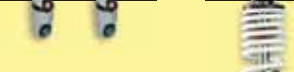

PIAGGIO

MP3
ie euro 3
2014->MP3 YOURBAN 4V
ie euro 3
2011->MP3
ie euro 3MP3
ie euro 3

(M862M)

(MASTER M474M)

300 4T LC 300 4T LC 400 4T LC 500 4T LC



CHECK "TYPE" SPECIFICATION (HOMOLOGATION MARK).		300 4T	LC	300 4T	LC	400 4T	LC	500 4T	LC
	CLUTCH DISK SET FOR ORIGINAL CLUTCH	-	-	-	-	-	-	-	-
	MAXI WILD LION   HOMOLOGATED EXHAUST SYSTEM	-	-	-	-	3214374 *69* € 476,34	3214374 *69* € 476,34	-	-
	RX   HOMOLOGATED EXHAUST SYSTEM	-	-	3214821 € 339,50	-	-	-	-	-
	RED CHILLI OIL OIL FILTER	0313382 € 7,00	-	0313382 € 7,00	-	0313383 € 7,42	-	0313383 € 7,42	-
	RED SPONGE FOR ORIGINAL AIR BOX	-	-	1412129 € 5,10	-	1412129 € 5,10	-	1412129 € 5,10	-
	DOUBLE RED SPONGE FOR ORIGINAL AIR BOX	-	-	1414496 € 7,35	-	1414496 € 7,35	-	1414496 € 7,35	-
	W BOX FOR ORIGINAL AIR BOX	-	-	-	-	-	-	-	-
	V FILTER VARIATOR AIR FILTER RIGHT SIDE	-	-	-	-	-	-	-	-
	POWER TRASMISSION	-	-	-	-	-	-	-	-
	GEARS HTQ PRIMARY	-	-	-	-	-	-	-	-
	GEARS HTQ SECONDARY	-	-	-	-	-	-	-	-
	SPORT SCREEN SCREEN	-	-	-	-	-	-	-	-
	MHR SCREEN SCREEN	-	-	-	-	-	-	-	-
	HOSE KIT FOR BRAKE	-	-	-	-	-	-	-	-
	BRAKE PADS FRONT ORGANIC BRAKE PADS	-	-	6215049 € 6,24	-	6215049 € 6,24	-	-	-
	BRAKE PADS MHR FRONT ORGANIC BRAKE PADS	-	-	6215074 € 6,30	-	6215074 € 6,30	-	-	-
	BRAKE PADS MHR SYNT FRONT SINTERED BRAKE PADS	6215015 € 16,64	-	6215006 € 11,96	-	6215006 € 11,96	-	-	-
	BRAKE PADS REAR ORGANIC BRAKE PADS	-	-	-	-	6215062 € 8,32	-	-	-
	BRAKE PADS MHR REAR ORGANIC BRAKE PADS	-	-	-	-	6215079 € 8,20	-	-	-
	BRAKE PADS MHR SYNT REAR SINTERED BRAKE PADS	-	-	-	-	6215013 € 16,50	-	-	-
	BRAKE POWER REAR BRAKE SHOES	-	-	-	-	-	-	-	-
	DISC / WHOOP DISC / PAIR WHOOP FRONT BRAKE DISC	-	-	-	-	-	-	-	-
	DISC / WHOOP DISC REAR BRAKE DISC	6212351 € 88,30	-	6212351 € 88,30	-	-	-	-	-
	TWINS MAXI SUSPENSIONS REAR PAIR SHOCK ABSORBER	-	-	-	-	4614789 € 261,00	-	-	-
	RS3 - RS1 REAR SHOCK ABSORBER	-	-	-	-	-	-	-	-
	RS24 REAR SHOCK ABSORBER	-	-	-	-	-	-	-	-
	RS24 FRONT SHOCK ABSORBER	-	-	-	-	-	-	-	-
	RS24 FRONT + REAR	-	-	-	-	-	-	-	-
	F32S FORK STEMS Ø 32	-	-	-	-	-	-	-	-
	F37R FORK STEMS Ø 37	-	-	-	-	-	-	-	-

07 - for vehicles WITH BREMBO CALIPER

08 - for vehicles WITH Heng Tong CALIPER

69 - ONLY homologated SILENCER

PIAGGIO

SKIPPER ST	SKIPPER ST	TYPHOON euro 3	X7 euro 3	X7 EVO ie euro 3	X7 ie euro 3	X7 EVO ie euro 3	X8 euro 2-3
(LEADER)	(LEADER)	(LEADER M701M)	(LEADER)	(QUASAR)	(QUASAR M622M)	(QUASAR)	(LEADER)
125 4T 	150 4T 	125 4T 	125 4T LC	125 4T LC	250 4T LC	300 4T LC	125 4T LC
-	-	-	-	-	-	-	-
-	-	-	-	-	-	-	-
-	-	-	-	-	-	-	-
0313382 € 7,00	0313382 € 7,00	0313382 € 7,00	0313382 € 7,00	0313382 € 7,00	0313382 € 7,00	0313382 € 7,00	0313382 € 7,00
-	-	-	1412129 € 5,10	1412129 € 5,10	1412129 € 5,10	1412129 € 5,10	-
-	-	1414532 € 6,70	1414496 € 7,35	1414496 € 7,35	1414496 € 7,35	1414496 € 7,35	-
-	-	-	-	-	-	-	-
-	-	-	-	-	-	-	-
-	-	-	-	-	-	-	-
-	-	-	-	-	-	-	-
6712067 € 69,96 z 15/41	6712067 € 69,96 z 15/41	6712067 € 69,96 z 15/41	6712067 € 69,96 z 15/41	6712067 € 69,96 z 15/41	-	-	6712067 € 69,96 z 15/41
-	-	-	-	-	-	-	-
-	-	-	-	-	-	-	-
6215047 € 6,76 1993->97	6215047 € 6,76 1993->97	6215062 € 8,32	-	-	6215062 € 8,32	6215062 € 8,32	-
62 9088 € 6,55 1993->97	62 9088 € 6,55 1993->97	6215079 € 8,20	-	-	6215079 € 8,20	6215079 € 8,20	-
6215011 € 16,00 1998->	6215011 € 16,00 1998->	6215013 € 16,50	-	-	6215013 € 16,50	6215013 € 16,50	-
-	-	-	-	-	6215062 € 8,32	6215062 € 8,32	6216418 *08* € 8,85
-	-	-	-	-	6215079 € 8,20	6215079 € 8,20	-
-	-	-	-	-	6215013 € 16,50	6215013 € 16,50	6215017 *07* € 15,00
-	-	-	-	-	-	-	-
-	-	-	-	-	6212352 € 95,83	6212352 € 95,83	6212352 € 95,83
-	-	-	-	-	6212351 € 88,30	6212351 € 88,30	6212351 € 88,30
-	-	-	-	-	-	-	4613181 € 219,90
-	-	-	-	-	-	-	-
-	-	-	-	-	-	-	-
-	-	-	-	-	-	-	-
-	-	-	-	-	-	-	-
-	-	-	-	-	-	-	-
-	-	-	-	-	-	-	-
-	-	-	-	-	-	-	-
-	-	-	-	-	-	-	-
-	-	-	-	-	-	-	-
-	-	-	-	-	-	-	-

MAXI SCOOTER 125 → 800 4T



MALOSSI

Maxi Scooter

125 → 800 4T

with ENGINE 

PIAGGIO

X8

X8
euro 2X8
ie euro 3X8
ie euro 3

(QUASAR)

(M521M)

200 4T

LC

250 4T

LC

250 4T

LC

400 4T

LC

	CYLINDER 4 STROKE ALUMINIUM	3113955 € 335,00 Ø 75,5	3113928 € 335,00 Ø 74	3113928 € 335,00 Ø 74	-
	CYLINDER I-TECH ALUMINIUM EQUIPPED WITH CDI	-	-	-	-
	POWER CAM CAMSHAFT	5911962 € 218,53	-	-	5913846 € 227,63
	HEAD V4 HEAD FOR ORIGINAL CYLINDER / MALOSSI	*01*	3813273 € 475,00	3813273 € 475,00	-
	CYLINDER + V4 HEAD ALUMINIUM	-	3113927 € 745,00 Ø 74	3113927 € 745,00 Ø 74	-
	CYLINDER + V4 HEAD + POWER CAM ALUMINIUM Ø 75,5	3116208 € 895,00	-	-	-
	4 STROKE VALVE FOR ENGINE VALVES SET	2714047 € 118,53	2714047 € 118,53	2714047 € 118,53	-
	SPRINGS FOR ENGINE VALVES	2912834 € 21,54	2912834 € 21,54	2912834 € 21,54	2913068 € 22,74
	CRANKSHAFT RHQ	5312896 € 380,00	-	-	-
	IGNITION CONTROLLER DIGITRONIC FOR VEHICLES WITHOUT IMMOBILIZER	5512524 € 170,46	-	-	-
	IGNITION CONTROLLER DIGITRONIC FOR VEHICLES WITH IMMOBILIZER	5512341 € 170,46	-	-	-
	FORCE MASTER INJECTION CONTROLLER	-	5515724 € 255,84	5515724 € 255,84	-
	TC UNIT O2 controller LAMBDA EMULATOR	-	-	5514749 € 84,00	-
	MULTIVAR 2000 VARIATOR MULTIVAR 2000 MHR	5111885 € 112,35	5111885 € 112,35	5111885 € 112,35	5114260 € 173,04
	X SPECIAL BELT BELT X K BELT BELT	6115666 € 46,92	6113027 € 59,12	6113027 € 59,12	6115125 € 88,54
	HTRoll ROLLERS FOR MULTIVAR 2000 / MHR	6611095.R0 € 13,64 gr.14	6611095.T0 € 13,64 gr.15	6611095.T0 € 13,64 gr.15	6613554.B0 € 26,00 gr.15
	HTRoll ROLLERS FOR ORIGINAL VARIATOR	6613697.I0 € 18,00 gr.11	-	6613697.I0 € 18,00 gr.11	6613554.C0 € 26,00 gr.16
	VENTILVAR 2000 FIXED HALF-PULLEY	-	-	-	-
	VARIABLE-SPEED DRIVE ADJUSTER SPRING FOR VARIATOR	PG.445	PG.445	PG.445	PG.445
	TORSION CONTROLLER ANTIFRICTION FIFTH WHEEL	2513210 € 5,72	2513210 € 5,72	2513210 € 5,72	-
	TORQUE DRIVER MOBILE DRIVEN SPLIT PULLEY	6112563 € 197,30	6112563 € 197,30	6112563 € 197,30	-
	OVER RANGE TRANSMISSION KIT	-	-	-	-
	MAXI FLY CLUTCH NOT ADJUSTABLE CLUTCH	-	-	-	5212813 € 146,14
	MAXI DELTA CLUTCH ADJUSTABLE CLUTCH	5211821 € 120,42	5211821 € 120,42	5211821 € 120,42	-
	MAXI CLUTCH BELL CLUTCH BELL (SMOOTH RING)	-	-	-	-
	MAXI WING CLUTCH BELL CLUTCH BELL (FINNED RING)	7715898B € 52,00 Ø 134	7715898B € 52,00 Ø 134	7715898B € 52,00 Ø 134	7715579B € 49,00 Ø 160
	MAXI FLY SYSTEM CLUTCH BELL + NOT ADJUSTABLE CLUTCH	-	-	-	5216202 € 149,94 Ø 160
	MAXI DELTA SYSTEM CLUTCH BELL + ADJUSTABLE CLUTCH	5216918 € 136,00 Ø 134	5216918 € 136,00 Ø 134	5216918 € 136,00 Ø 134	-
	SPRINGS FOR MAXI FLY CLUTCH	-	-	-	2913137 € 20,99
	SPRINGS FOR MAXI DELTA CLUTCH	2911326 € 17,00	2911326 € 17,00	2911326 € 17,00	-
	SPRINGS FOR ORIGINAL CLUTCH	2911326 € 17,00	2911326 € 17,00	2911326 € 17,00	2912779 € 21,00

Products to be used exclusively for racing in places specially designed for such activity according to the regulations of the competent sporting authorities. We accept no liability resulting from improper use.

01 - TO COUPLE ONLY with MALOSSİ CYLINDERS: 3813273 € 475,00

62 - TO COUPLE ONLY with MALOSSİ CYLINDERS : 5911962 € 218,53

70 - For vehicles WITH ORIGINAL half-pulley "marked": "GF" 2911072.W0 - "FG" 2911074.Y0 € 10,71

PIAGGIO

X9 4V	X9 4V Evolution euro 2-3	X9 AMALFI	X9	X9	X9 Evolution	X9 Evolution - Street	X10 ie euro 3
				(HONDA)	(M237M)		
125 4T LC	125 4T LC	180 4T LC	200 4T LC	250 4T LC	250 4T LC	500 4T LC	125 4T LC
3113955 € 335,00 Ø 75,5	3113955 € 335,00 Ø 75,5	3113955 € 335,00 Ø 75,5	3113955 € 335,00 Ø 75,5	-	3113928 € 335,00 Ø 74	-	-
-	-	-	-	-	-	-	-
62	*62*	5911962 € 218,53	5911962 € 218,53	5911733 € 152,00	-	5913846 € 227,63	-
01	*01*	*01*	*01*	-	3813273 € 475,00	-	-
-	-	-	-	-	3113927 € 745,00 Ø 74	-	-
3116208 € 895,00	3116208 € 895,00	3116208 € 895,00	3116208 € 895,00	-	-	-	-
2714047 € 118,53	2714047 € 118,53	2714047 € 118,53	2714047 € 118,53	2711826 € 63,64	2714047 € 118,53	-	-
2912834 € 21,54	2912834 € 21,54	2912834 € 21,54	2912834 € 21,54	-	2912834 € 21,54	2913068 € 22,74	2912834 € 21,54
5312853 € 380,00	5312853 € 380,00	5312896 € 380,00	5312896 € 380,00	-	-	-	-
5512524 € 170,46	5512524 € 170,46	5512524 € 170,46	5512524 € 170,46	-	-	-	-
5512341 € 170,46	5512341 € 170,46	5512341 € 170,46	5512341 € 170,46	-	-	-	-
-	-	-	-	-	5515724 € 255,84	-	-
-	-	-	-	-	-	-	5514746 € 90,00
5111397 € 112,35	5111397 € 112,35	5111594 € 112,35	5111885 € 112,35	5111226 € 127,65	5111885 € 112,35	5114260 (8 rollers) € 173,04 5111808 (6 rollers) € 172,79	5111397 € 112,35
6116117 € 34,27	6116117 € 34,27	6115666 € 46,92	6115666 € 46,92	6113189 € 39,78	6113027 € 59,12	6115125 € 88,54	6116118 € 35,00
6611095.G0 € 13,64 gr.09,5	6611095.G0 € 13,64 gr.09,5	6611095.R0 € 13,64 gr.14	6611095.R0 € 13,64 gr.14	66 9917.M0 € 19,12 gr.18	6611095.T0 € 13,64 gr.15	6613554.B0 gr.15 (8) € 26,00 6613968.A0 gr.20 (6) € 17,81	6611095.G0 € 13,64 gr.09,5
66 9456.D0 € 12,00 gr.07,4	66 9456.D0 € 12,00 gr.07,4	66 9456.I0 € 12,00 gr.10,7	6613697.I0 € 18,00 gr.11	66 9917.U0 € 19,12 gr.25	6613697.I0 € 18,00 gr.11	6612124.G0 € 15,59 gr.30 (6 rollers)	66 9456.D0 € 12,00 gr.07,4
-	-	-	-	6111347B € 36,72	-	-	-
PG.445	PG.445	PG.445	PG.445	*70*	PG.445	PG.445	PG.445
2513210 € 5,72	2513210 € 5,72	2513210 € 5,72	2513210 € 5,72	-	2513210 € 5,72	-	2513210 € 5,72
6111656 € 123,88	6111656 € 123,88	6111656 € 123,88	6112563 2003-> € 197,30 6111656 <-2002 € 123,88	6111964 € 177,16	6112563 € 197,30	-	6111656 € 123,88
-	-	-	-	-	-	-	-
-	-	-	-	-	-	5212813 € 146,14	-
5211821 € 120,42	5211821 € 120,42	5211821 € 120,42	5211821 € 120,42	5211467 € 129,23	5211821 € 120,42	-	5211821 € 120,42
-	-	-	-	-	-	-	-
7715898B € 52,00 Ø 134	7715898B € 52,00 Ø 134	7715898B € 52,00 Ø 134	7715898B € 52,00 Ø 134	7715916B € 52,00 Ø 135	7715898B € 52,00 Ø 134	7715579B € 49,00 Ø 160	7715898B € 52,00 Ø 134
-	-	-	-	-	-	5216202 € 149,94 Ø 160	-
5216918 € 136,00 Ø 134	5216918 € 136,00 Ø 134	5216918 € 136,00 Ø 134	5216918 € 136,00 Ø 134	5216184 € 136,00 Ø 135	5216918 € 136,00 Ø 134	-	5216918 € 136,00 Ø 134
-	-	-	-	-	-	2913137 € 20,99	-
2911326 € 17,00	2911326 € 17,00	2911326 € 17,00	2911326 € 17,00	2911326 € 17,00	2911326 € 17,00	-	2911326 € 17,00
2911326 € 17,00	2911326 € 17,00	2911326 € 17,00	2911326 € 17,00	2911326 € 17,00	2911326 € 17,00	2912779 (5 masses) € 21,00 2911326 (3 masses) € 15,94	2911326 € 17,00



MALOSSİ

Maxi Scooter

125 → 800 4T

with ENGINE 

PIAGGIO

X8











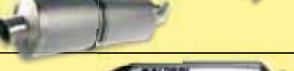

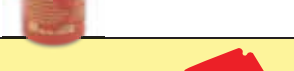













X8
euro 2X8
ie euro 3X8
ie euro 3

(QUASAR)

(M521M)

() CHECK "TYPE" SPECIFICATION (HOMOLOGATION MARK).

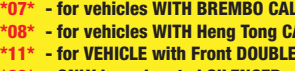
200 4T LC 250 4T LC 250 4T LC 400 4T LC

	CLUTCH DISK SET FOR ORIGINAL CLUTCH		-	-	-	-
	MAXI WILD LION () HOMOLOGATED EXHAUST SYSTEM		-	-	-	3214374 *69* € 476,34
	RX () HOMOLOGATED EXHAUST SYSTEM		-	-	-	-
	RED CHILLI OIL OIL FILTER		0313382 € 7,00	0313382 € 7,00	0313382 € 7,00	0313383 € 7,42
	RED SPONGE FOR ORIGINAL AIR BOX		-	-	-	1412129 € 5,10
	DOUBLE RED SPONGE FOR ORIGINAL AIR BOX		-	-	-	1414496 € 7,35
	W BOX FOR ORIGINAL AIR BOX		-	-	-	-
	V FILTER VARIATOR AIR FILTER RIGHT SIDE		-	-	-	-
	POWER TRASMISSION		-	-	-	-
	GEARS HTQ PRIMARY		-	-	-	-
	GEARS HTQ SECONDARY		6711860 € 60,41 z 16/42	-	-	-
	SPORT SCREEN SCREEN		-	-	-	-
	MHR SCREEN SCREEN		-	-	-	-
	HOSE KIT FOR BRAKE		-	-	-	-
	BRAKE PADS FRONT ORGANIC BRAKE PADS		-	6215062 € 8,32	6215062 € 8,32	6215062 *11* € 8,32 LEFT
	BRAKE PADS MHR FRONT ORGANIC BRAKE PADS		-	6215079 € 8,20	6215079 € 8,20	6215079 *11* € 8,20 LEFT
	BRAKE PADS MHR SYNT FRONT SINTERED BRAKE PADS		-	6215013 € 16,50	6215013 € 16,50	6215013 *11* € 16,50 LEFT
	BRAKE PADS REAR ORGANIC BRAKE PADS		6216418 *08* € 8,85	6216896 € 9,50	-	6215062 *11* € 8,32
	BRAKE PADS MHR REAR ORGANIC BRAKE PADS		-	-	-	6215079 *11* € 8,20
	BRAKE PADS MHR SYNT REAR SINTERED BRAKE PADS		6215017 *07* € 15,00	6215017 € 15,00	-	6215013 *11* € 16,50
	BRAKE POWER REAR BRAKE SHOES		-	-	-	-
	DISC / WHOOP DISC / PAIR WHOOP FRONT BRAKE DISC		6212352 € 95,83	6212352 € 95,83	6212352 € 95,83	6212351 *11* € 88,30
	DISC / WHOOP DISC REAR BRAKE DISC		6212351 € 88,30	6212351 € 88,30	6212351 € 88,30	6212351 *11* € 88,30
	TWINS MAXI SUSPENSIONS REAR PAIR SHOCK ABSORBER		4613181 € 219,90	-	4613181 € 219,90	-
	RS3 - RS1 REAR SHOCK ABSORBER		-	-	-	-
	RS24 REAR SHOCK ABSORBER		-	-	-	-
	RS24 FRONT SHOCK ABSORBER		-	-	-	-
	RS24 FRONT + REAR		-	-	-	-
	F32S FORK STEMS Ø 32		-	-	-	-
	F37R FORK STEMS Ø 37		-	-	-	-

07 - for vehicles WITH BREMBO CALIPER
 08 - for vehicles WITH Heng Tong CALIPER
 11 - for VEHICLE with Front DOUBLE DISC
 69 - ONLY homologated SILENCER

PIAGGIO

X9 4V		X9 4V Evolution euro 2-3		X9 AMALFI		X9		X9		X9 Evolution		X9 Evolution - Street		X10 ie euro 3	
								(HONDA)		(M237M)					
125 4T	LC	125 4T	LC	180 4T	LC	200 4T	LC	250 4T	LC	250 4T	LC	500 4T	LC	125 4T	LC
-		-		-		-		-		-		-		-	
-		-		-		-		-		-		3214374	*69*	-	
-		-		-		-		-		-		€ 476,34		-	
0313382		0313382		0313382		0313382		-		0313382		0313383		0313382	
€ 7,00		€ 7,00		€ 7,00		€ 7,00		-		€ 7,00		€ 7,42		€ 7,00	
1412129		-		-		1412129		-		1412129		-		1412129	
€ 5,10		-		-		€ 5,10	<-2005	-		€ 5,10		-		€ 5,10	
1414496		-		-		1414496		-		1414496		-		1414496	
€ 7,35		-		-		€ 7,35	<-2005	-		€ 7,35		-		€ 7,35	
-		-		-		-		-		-		-		-	
-		-		-		-		-		-		-		-	
-		-		-		-		-		-		-		-	
-		-		-		-		-		-		-		-	
6712067		6712067		6712067		6711860		67 9983		-		-		-	
€ 69,96	z 15/41	€ 69,96	z 15/41	€ 69,96	z 15/41	€ 60,41	z 16/42	€ 90,27	z 17/37	-		-		-	
-		-		-		-		-		-		-		4515655B	
-		-		-		-		-		-		-		€ 72,00	
-		-		6216896		-		6216896		-		6215052		-	
-		-		€ 9,50	2001->	-		€ 9,50	2000->	-		€ 8,00	2001->	-	
-		-		-		-		-		-		6211525		-	
-		-		-		-		-		-		€ 8,20	2001->	-	
-		-		6215017		-		6215017		-		6215020		-	
-		-		€ 15,00	2001->	-		€ 15,00	2000->	-		€ 16,00	2001->	-	
-		6216418	*08*	6216896		-		6216896		6216418	*08*	6216896		-	
-		€ 8,85		€ 9,50	2001->	-		€ 9,50	2000->	€ 8,85	RIGHT	€ 9,50	2001->	-	
-		-		-		-		-		-		-		-	
-		6215017	*07*	6215017		-		6215017		6215017	*07*	6215017		-	
-		€ 15,00		€ 15,00	2001->	-		€ 15,00	2000->	€ 15,00		€ 15,00	2001->	-	
-		-		-		-		-		-		-		-	
6212351		-		6212351		6212351		6211702 2000-> € 83,67		6212351		6212352		-	
€ 88,30		-		€ 88,30		€ 88,30		6212351 2000-> € 88,30		€ 88,30		€ 95,83	2001->	-	
-		-		-		-		-		6212351		6211702		-	
-		-		-		-		-		€ 88,30		€ 83,67	2001->	-	
-		-		-		-		-		-		-		-	
-		-		-		-		-		-		-		-	
-		-		-		-		-		-		-		-	
-		-		-		-		-		-		-		-	
-		-		-		-		-		-		-		-	
-		-		-		-		-		-		-		-	
-		-		-		-		-		-		-		-	
-		-		-		-		-		-		-		-	
-		-		-		-		-		-		-		-	
-		-		-		-		-		-		-		-	



MALOSSI

Maxi Scooter

125 → 800 4T

with ENGINE 

PIAGGIO

X10
ie euro 3X10
ie euro 3XEvo
euro 3XEvo
ie euro 3

(M762M)

(LEADER)

(QUASAR)

350 4T

LC

500 4T

LC

125 4T

LC

250 4T

LC



	CYLINDER 4 STROKE ALUMINIUM	-	-	3113955 € 335,00 Ø 75,5	3113928 € 335,00 Ø 74
	CYLINDER I-TECH ALUMINIUM EQUIPPED WITH CDI	-	-	-	-
	POWER CAM CAMSHAFT	-	5913846 € 227,63	*62*	-
	HEAD V4 HEAD FOR ORIGINAL CYLINDER / MALOSSI	-	-	*01*	3813273 € 475,00
	CYLINDER + V4 HEAD ALUMINIUM	-	-	-	3113927 € 745,00 Ø 74
	CYLINDER + V4 HEAD + POWER CAM ALUMINIUM Ø 75,5	-	-	3116208 € 895,00	-
	4 STROKE VALVE FOR ENGINE VALVES SET	-	-	2714047 € 118,53	2714047 € 118,53
	SPRINGS FOR ENGINE VALVES	-	2913068 € 22,74	2912834 € 21,54	2912834 € 21,54
	CRANKSHAFT RHQ	-	-	5312853 € 380,00	-
	IGNITION CONTROLLER DIGITRONIC FOR VEHICLES WITHOUT IMMOBILIZER	-	-	-	-
	IGNITION CONTROLLER DIGITRONIC FOR VEHICLES WITH IMMOBILIZER	-	-	-	-
	FORCE MASTER INJECTION CONTROLLER	5515723 € 255,84	-	-	5515724 € 255,84
	TC UNIT 02 controller LAMBDA EMULATOR	5514746 € 90,00	-	-	5514749 € 84,00
	MULTIVAR 2000 VARIATOR MULTIVAR 2000 MHR	5115308 € 152,44	5114260 € 173,04	5111397 € 112,35	5111885 € 112,35
	X SPECIAL BELT BELT X K BELT BELT	6115279 € 72,32	6115125 € 88,54	6116117 € 34,27	6113027 € 59,12
	HTRoll ROLLERS FOR MULTIVAR 2000 / MHR	6615452.I0 € 27,00 gr.10	6613554.B0 € 26,00 gr.15	6611095.G0 € 13,64 gr.09,5	6611095.T0 € 13,64 gr.15
	HTRoll ROLLERS FOR ORIGINAL VARIATOR	6615452.C0 € 27,00 gr.16	-	66 9456.D0 € 12,00 gr.07,4	6613697.I0 € 18,00 gr.11
	VENTILVAR 2000 FIXED HALF-PULLEY	-	-	-	-
	VARIABLE-SPEED DRIVE ADJUSTER SPRING FOR VARIATOR	PG. 445 2915315.W0*PG* € 15,97	PG.445	PG.445	PG.445
	TORSION CONTROLLER ANTIFRICTION FIFTH WHEEL	-	-	2513210 € 5,72	2513210 € 5,72
	TORQUE DRIVER MOBILE DRIVEN SPLIT PULLEY	-	-	6111656 € 123,88	6112563 € 197,30
	OVER RANGE TRANSMISSION KIT	-	-	-	-
	MAXI FLY CLUTCH NOT ADJUSTABLE CLUTCH	-	5212813 € 146,14	-	-
	MAXI DELTA CLUTCH ADJUSTABLE CLUTCH	-	-	5211821 € 120,42	5211821 € 120,42
	MAXI CLUTCH BELL CLUTCH BELL (SMOOTH RING)	-	-	-	-
	MAXI WING CLUTCH BELL CLUTCH BELL (FINNED RING)	-	7715579B € 49,00 Ø 160	7715898B € 52,00 Ø 134	7715898B € 52,00 Ø 134
	MAXI FLY SYSTEM CLUTCH BELL + NOT ADJUSTABLE CLUTCH	-	5216202 € 149,94 Ø 160	-	-
	MAXI DELTA SYSTEM CLUTCH BELL + ADJUSTABLE CLUTCH	-	-	5216918 € 136,00 Ø 134	5216918 € 136,00 Ø 134
	SPRINGS FOR MAXI FLY CLUTCH	-	2913137 € 20,99	-	-
	SPRINGS FOR MAXI DELTA CLUTCH	-	-	2911326 € 17,00	2911326 € 17,00
	SPRINGS FOR ORIGINAL CLUTCH	2915398 € 19,90	2912779 € 21,00	2911326 € 17,00	2911326 € 17,00

Products to be used exclusively for racing in places specially designed for such activity according to the regulations of the competent sporting authorities. We accept no liability resulting from improper use.

01 - TO COUPLE ONLY with MALOSSİ CYLINDERS: 3813273 € 475,00

62 - TO COUPLE ONLY with MALOSSİ CYLINDERS : 5911962 € 218,53

PG - SPECIFICATIONS on the PAGE indicated in the TITLE of the LINE

PIAGGIO		QUADRO		RENAULT		SUZUKI									
XEvo ie euro 3		ZIP		Die		FULLTIME		BURGMAN K 7 ie euro 3		BURGMAN UH		BURGMAN UH ie euro 3			
(M521M)		(LEADER)		(T62N)		(LEADER)		(F490)							
400 4T	LC	125 4T		350 4T	LC	125 4T		125 4T	LC	125 4T	LC	150 4T	LC	200 4T	LC
-		3111393		-		3111393		-		-		-		-	
		€ 302,60	Ø 70			€ 302,60	Ø 70								
-		-		-		-		-		-		-		-	
5913846		-		-		-		-		-		-		-	
€ 227,63															
-		-		-		-		-		-		-		-	
-		-		-		-		-		-		-		-	
-		-		-		-		-		-		-		-	
-		-		-		-		-		-		-		-	
2913068		-		-		-		-		-		-		-	
€ 22,74															
-		-		-		-		-		-		-		-	
-		-		-		-		-		-		-		-	
-		-		-		-		-		-		-		-	
-		-		-		-		-		-		-		-	
5114260		5111397		-		5111397		5111324		5111324		5111324		5113393	
€ 173,04		€ 112,35				€ 112,35		€ 112,35		€ 112,35		€ 112,35		€ 136,15	
6115125		6116117		-		6116117		6113502		-		-		61 9956	
€ 88,54		€ 34,27				€ 34,27		€ 48,57						€ 42,23	
6613554.B0		6611095.G0		-		6611095.G0		6611095.H0		6611095.H0		6611095.H0		66 9917.A0	
€ 26,00	gr.15	€ 13,64	gr.09,5			€ 13,64	gr.09,5	€ 13,64	gr.10	€ 13,64	gr.10	€ 13,64	gr.10	€ 19,12	gr.12
6613554.C0		66 9456.F0		-		66 9456.F0		-		-		-		-	
€ 26,00	gr.16	€ 12,00	gr.08,7			€ 12,00	gr.08,7								
-		-		-		-		-		-		-		-	
PG.445		PG.445		-		PG.445		2914203.W0*PG*		2914203.W0*PG*		2914203.W0*PG*		2912647.Y0 *PG*	
								€ 10,00		€ 10,00		€ 10,00		€ 10,00	
-		2513210		-		2513210		-		-		-		-	
		€ 5,72				€ 5,72									
-		6111656		-		6111656		-		-		-		-	
		€ 123,88				€ 123,88									
-		-		-		-		-		-		-		-	
5212813		-		-		-		-		-		-		-	
€ 146,14															
-		5211821		-		5211821		-		-		-		-	
		€ 120,42				€ 120,42									
-		-		-		-		-		-		-		-	
7715579B		7715898B		-		7715898B		-		-		-		-	
€ 49,00	Ø 160	€ 52,00	Ø 134			€ 52,00	Ø 134								
5216202		-		-		-		-		-		-		-	
€ 149,94	Ø 160														
-		5216918		-		5216918		-		-		-		-	
		€ 136,00	Ø 134			€ 136,00	Ø 134								
2913137		-		-		-		-		-		-		-	
€ 20,99															
-		2911326		-		2911326		-		-		-		-	
		€ 17,00				€ 17,00									
2912779		2911326		2915089		2911326		29 9605		-		-		2911326	
€ 21,00		€ 17,00		€ 16,20		€ 17,00		€ 16,20						€ 17,00	



MALOSSI

Maxi Scooter

125 → 800 4T

with ENGINE 

PIAGGIO

X10
ie euro 3X10
ie euro 3XEvo
euro 3XEvo
ie euro 3











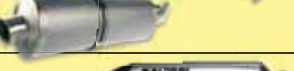



















(M762M)

(LEADER)

(QUASAR)

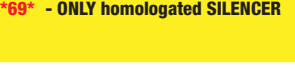

CHECK "TYPE" SPECIFICATION (HOMOLOGATION MARK).

350 4T LC 500 4T LC 125 4T LC 250 4T LC

	CLUTCH DISK SET FOR ORIGINAL CLUTCH		5215609 € 65,00	-	-	-
	MAXI WILD LION  HOMOLOGATED EXHAUST SYSTEM		-	-	-	-
	RX  HOMOLOGATED EXHAUST SYSTEM	 	3215561 € 380,00	-	-	-
	RED CHILLI OIL OIL FILTER		-	0313383 € 7,42	0313382 € 7,00	0313382 € 7,00
	RED SPONGE FOR ORIGINAL AIR BOX		1415662 € 38,99	1412129 € 5,10	-	-
	DOUBLE RED SPONGE FOR ORIGINAL AIR BOX		-	1414496 € 7,35	-	-
	W BOX FOR ORIGINAL AIR BOX		-	-	-	-
	V FILTER VARIATOR AIR FILTER RIGHT SIDE		-	-	-	-
	POWER TRASMISSION		-	-	-	-
	GEARS HTQ PRIMARY		-	-	-	-
	GEARS HTQ SECONDARY		-	-	6712067 € 69,96 z 15/41	-
	SPORT SCREEN SCREEN		4515655B € 72,00	4515655B € 72,00	-	-
	MHR SCREEN SCREEN		-	-	-	-
	HOSE KIT FOR BRAKE		-	-	-	-
	BRAKE PADS FRONT ORGANIC BRAKE PADS		6215062 *11* € 8,32	-	-	-
	BRAKE PADS MHR FRONT ORGANIC BRAKE PADS		6215079 *11* € 8,20	-	-	-
	BRAKE PADS MHR SYNT FRONT SINTERED BRAKE PADS		6215013 *11* € 16,50	-	-	-
	BRAKE PADS REAR ORGANIC BRAKE PADS		6215062 *11* € 8,32	-	-	-
	BRAKE PADS MHR REAR ORGANIC BRAKE PADS		6215079 *11* € 8,20	-	-	-
	BRAKE PADS MHR SYNT REAR SINTERED BRAKE PADS		6215013 *11* € 16,50	-	-	-
	BRAKE POWER REAR BRAKE SHOES		-	-	-	-
	DISC / WHOOP DISC / PAIR WHOOP FRONT BRAKE DISC		-	-	-	-
	DISC / WHOOP DISC REAR BRAKE DISC		-	-	-	-
	TWINS MAXI SUSPENSIONS REAR PAIR SHOCK ABSORBER		-	-	-	-
	RS3 - RS1 REAR SHOCK ABSORBER		-	-	-	-
	RS24 REAR SHOCK ABSORBER		-	-	-	-
	RS24 FRONT SHOCK ABSORBER		-	-	-	-
	RS24 FRONT + REAR		-	-	-	-
	F32S FORK STEMS Ø 32		-	-	-	-
	F37R FORK STEMS Ø 37		-	-	-	-

11 - for VEHICLE with Front DOUBLE DISC

69 - ONLY homologated SILENCER

PIAGGIO		QUADRO		RENAULT		SUZUKI									
XEvo ie euro 3		ZIP		Die		FULLTIME		BURGMAN K 7 ie euro 3		BURGMAN UH		BURGMAN UH ie euro 3			
(M521M)		(LEADER)		(T62N)		(LEADER)		(F490)							
400 4T	LC	125 4T		350 4T	LC	125 4T		125 4T	LC	125 4T	LC	150 4T	LC	200 4T	LC
-		-		-		-		-		-		-		-	
3214374	*69*	-		-		-		-		-		-		-	
€ 476,34		-		-		-		-		-		-		-	
-		-		-		-		-		-		-		-	
0313383		0313382		-		0313382		-		0313379		0313379		-	
€ 7,42		€ 7,00		-		€ 7,00		-		€ 3,38		€ 3,38		-	
1412129		-		-		-		-		-		-		-	
€ 5,10		-		-		-		-		-		-		-	
1414496		-		-		-		-		-		-		-	
€ 7,35		-		-		-		-		-		-		-	
-		-		-		-		-		-		-		-	
-		-		-		-		-		-		-		-	
-		-		-		-		-		-		-		-	
-		-		-		-		-		-		-		-	
-		6711860		-		6712067		-		-		-		-	
-		€ 60,41	z 16/42	-		€ 69,96	z 15/41	-		-		-		-	
-		-		-		-		-		-		-		-	
-		-		-		-		-		-		-		-	
6215062	*11*	6215049		6215042		-		-		-		-		-	
€ 8,32	LEFT	€ 6,24	2000->	€ 5,72		-		-		-		-		-	
6215079	*11*	6215074		6215080		-		-		-		-		-	
€ 8,20	LEFT	€ 6,30	2000->	€ 6,00		-		-		-		-		-	
6215013	*11*	6215006		6215007		-		-		6215020		6215020		6215034	
€ 16,50	LEFT	€ 11,96	2000->	€ 11,96		-		-		€ 16,00		€ 16,00		€ 18,62	
6215062	*11*	-		6215059		-		-		6216896		6216896		-	
€ 8,32		-		€ 8,84		-		-		€ 9,50		€ 9,50		-	
6215079	*11*	-		6212164		-		-		-		-		-	
€ 8,20		-		€ 8,50		-		-		-		-		-	
6215013	*11*	-		-		6215015		-		6215017		6215017		-	
€ 16,50		-		-		€ 16,64		-		€ 15,00		€ 15,00		-	
-		6215328		-		-		-		-		-		-	
-		€ 18,39	2000->	-		-		-		-		-		-	
6212351	*11*	6212604		-		-		-		-		-		-	
€ 88,30		€ 76,38	2000->	-		-		-		-		-		-	
6212351	*11*	-		-		-		-		-		-		-	
€ 88,30		-		-		-		-		-		-		-	
-		-		-		-		-		-		-		-	
-		-		-		-		-		-		-		-	
-		-		-		-		-		-		-		-	
-		46 7900		-		-		-		-		-		-	
-		€ 222,63		-		-		-		-		-		-	
-		-		-		-		-		-		-		-	
-		-		-		-		-		-		-		-	
-		-		-		-		-		-		-		-	



MALOSSI

Maxi Scooter

125 → 800 4T

with ENGINE **SUZUKI**

BURGMAN AN

BURGMAN AN -
BusinessBURGMAN AN
ie
<-2007BURGMAN AN
K7 > K9
ie

(K429)

250 4T

LC

400 4T









LC

400 4T

LC

400 4T

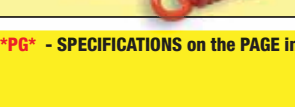
LC

	CYLINDER 4 STROKE ALUMINIUM	-	-	-	-
	CYLINDER I-TECH ALUMINIUM EQUIPPED WITH CDI	-	-	-	-
	POWER CAM CAMSHAFT	-	-	-	-
	HEAD V4 HEAD FOR ORIGINAL CYLINDER / MALOSSI	-	-	-	-
	CYLINDER + V4 HEAD ALUMINIUM	-	-	-	-
	CYLINDER + V4 HEAD + POWER CAM ALUMINIUM Ø 75,5	-	-	-	-
	4 STROKE VALVE FOR ENGINE VALVES SET	-	-	-	-
	SPRINGS FOR ENGINE VALVES	-	-	-	-
	CRANKSHAFT RHQ	-	-	-	-
	IGNITION CONTROLLER DIGITRONIC FOR VEHICLES WITHOUT IMMOBILIZER	-	-	-	-
	IGNITION CONTROLLER DIGITRONIC FOR VEHICLES WITH IMMOBILIZER	-	-	-	-
	FORCE MASTER INJECTION CONTROLLER	-	-	-	-
	TC UNIT O2 controller LAMBDA EMULATOR	-	-	-	-
	MULTIVAR 2000 VARIATOR	5111323	5114258	5114258	5114263
	MULTIVAR 2000 MHR	€ 136,15	€ 149,35	€ 149,35	€ 164,80
	X SPECIAL BELT BELT	61 9956	6112713	6112713	6113396
	X K BELT BELT	€ 42,23	€ 81,79	€ 81,79	€ 88,38
	HTRoll	66 9917.E0	6611367.E0	6611367.E0	6611367.C0
	ROLLERS FOR MULTIVAR 2000 / MHR	€ 19,12 gr.15	€ 23,75 gr.16	€ 23,75 gr.16	€ 23,75 gr.14
	HTRoll	66 9915.D0	6611367.L0	6611367.G0	6611367.G0
	ROLLERS FOR ORIGINAL VARIATOR	€ 17,80 gr.23	€ 23,75 gr.21	€ 23,75 gr.18	€ 23,75 gr.18
	VENTILVAR 2000 FIXED HALF-PULLEY	-	-	-	-
	VARIABLE-SPEED DRIVE ADJUSTER SPRING PG. 445 FOR VARIATOR	-	2911429.Y0 *PG* € 11,50	2911429.Y0 *PG* € 11,50	2911429.Y0 *PG* € 11,50
	TORSION CONTROLLER ANTIFRICTION FIFTH WHEEL	-	-	-	-
	TORQUE DRIVER MOBILE DRIVEN SPLIT PULLEY	-	-	-	-
	OVER RANGE TRANSMISSION KIT	-	-	-	-
	MAXI FLY CLUTCH NOT ADJUSTABLE CLUTCH	-	5213060 € 146,14	5213060 € 146,14	5213296 € 146,14
	MAXI DELTA CLUTCH ADJUSTABLE CLUTCH	5211887 € 129,23	-	-	-
	MAXI CLUTCH BELL CLUTCH BELL (SMOOTH RING)	-	7714329 € 115,00 Ø 150	7714329 € 115,00 Ø 150	7715576B € 65,00 Ø 160
	MAXI WING CLUTCH BELL CLUTCH BELL (FINNED RING)	-	-	-	-
	MAXI FLY SYSTEM CLUTCH BELL + NOT ADJUSTABLE CLUTCH	-	-	-	5216181 € 175,00 Ø 160
	MAXI DELTA SYSTEM CLUTCH BELL + ADJUSTABLE CLUTCH	-	-	-	-
	SPRINGS FOR MAXI FLY CLUTCH	-	2913137 € 20,99	2913137 € 20,99	2913137 € 20,99
	SPRINGS FOR MAXI DELTA CLUTCH	2911326 € 17,00	-	-	-
	SPRINGS FOR ORIGINAL CLUTCH	2911326 € 17,00	-	-	2914484 (5 masses) € 33,00 2911848 (3 masses) € 15,94

Products to be used exclusively for racing in places specially designed for such activity according to the regulations of the competent sporting authorities. We accept no liability resulting from improper use.

PG - SPECIFICATIONS on the PAGE indicated in the TITLE of the LINE

SUZUKI						SYM	
BURGMAN AN K10 > ie	BURGMAN AN	EPICURO	EPICURO	SIXTEEN euro 3	SIXTEEN euro 3	CITYCOM euro 3	EURO MX
				(F499)	(G421)	(LEA 1)	
400 4T LC	650 4T LC	125 4T LC	150 4T LC	125 4T LC	150 4T LC	300 4T LC	125 4T 
-	-	-	-	-	-	-	-
-	-	-	-	-	-	-	-
-	-	-	-	-	-	-	-
-	-	-	-	-	-	-	-
-	-	-	-	-	-	-	-
-	-	-	-	-	-	-	-
-	-	-	-	-	-	-	-
-	-	-	-	-	-	-	-
-	-	-	-	-	-	-	-
-	-	-	-	-	-	-	-
-	-	-	-	-	-	-	-
-	-	-	-	-	-	-	-
-	-	-	-	-	-	-	-
5116277 € 164,80	-	5111324 € 112,35	5111324 € 112,35	5111324 € 112,35	5111324 € 112,35	5113597 € 136,15	5114273 € 112,35
6113396 € 88,38	-	-	-	6114127 € 24,42 6116422 € 48,57	6114127 € 24,42 6116422 € 48,57	-	-
6611367.C0 € 23,75 gr.14	-	6611095.H0 € 13,64 gr.10	6611095.H0 € 13,64 gr.10	6611095.H0 € 13,64 gr.10	6611095.H0 € 13,64 gr.10	66 9917.Q0 € 19,12 gr.20	6611095.M0 € 13,64 gr.11,5
6611367.G0 € 23,75 gr.18	-	-	-	-	-	-	6614705.B0 € 16,50 gr.10
-	-	-	-	-	-	-	-
2916114.W0*PG* € 14,00	-	2914203.W0*PG* € 10,00	2914203.W0*PG* € 10,00	2914203.W0*PG* € 10,00	2914203.W0*PG* € 10,00	2911074.Y0 *PG* € 10,71	2911266.Y0 *PG* € 10,71
-	-	-	-	-	-	-	-
-	-	-	-	-	-	-	-
-	-	-	-	-	-	-	-
5213296 € 146,14	-	-	-	-	-	-	-
-	-	-	-	-	-	5211835 € 128,41	-
7715576B € 65,00 Ø 160	-	-	-	-	-	-	-
-	-	-	-	-	-	-	-
5216181 € 175,00 Ø 160	-	-	-	-	-	-	-
-	-	-	-	-	-	-	-
2913137 € 20,99	-	-	-	-	-	-	-
-	-	-	-	-	-	-	-
2914484 € 33,00	-	-	-	29 9605 € 16,20	29 9605 € 16,20	2911848 € 17,00	-
						2911848 € 17,00	-





MALOSSİ

Maxi Scooter

125 → 800 4T

with ENGINE **SUZUKI**

BURGMAN AN

BURGMAN AN -
BusinessBURGMAN AN
ie
<-2007BURGMAN AN
K 7 > K 9
ie

(K429)

250 4T

LC

400 4T

LC











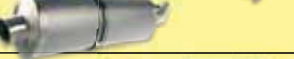









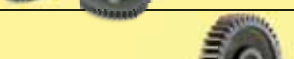



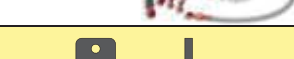

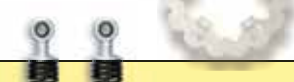

400 4T

LC

400 4T

LC

(■) CHECK "TYPE" SPECIFICATION (HOMOLOGATION MARK).

	CLUTCH DISK SET FOR ORIGINAL CLUTCH		-	-	-	-
	MAXI WILD LION   HOMOLOGATED EXHAUST SYSTEM		-	-	-	-
	RX   HOMOLOGATED EXHAUST SYSTEM		-	-	-	3214834 € 380,00
	RED CHILLI OIL OIL FILTER		0313380 € 3,80	0313380 € 3,80	0313380 € 3,80	0313379 € 3,38
	RED SPONGE FOR ORIGINAL AIR BOX		-	1412432 € 4,19	1412432 € 4,19	-
	DOUBLE RED SPONGE FOR ORIGINAL AIR BOX		-	1414513 € 6,63	1414513 € 6,63	-
	W BOX FOR ORIGINAL AIR BOX		-	-	-	-
	V FILTER VARIATOR AIR FILTER RIGHT SIDE		-	-	-	-
	POWER TRASMISSION		-	-	-	-
	GEARS HTQ PRIMARY		-	-	-	-
	GEARS HTQ SECONDARY		-	-	-	-
	SPORT SCREEN SCREEN		-	-	-	-
	MHR SCREEN SCREEN		-	-	-	-
	HOSE KIT FOR BRAKE		-	-	-	-
	BRAKE PADS FRONT ORGANIC BRAKE PADS		-	-	-	-
	BRAKE PADS MHR FRONT ORGANIC BRAKE PADS		-	-	-	-
	BRAKE PADS MHR SYNT FRONT SINTERED BRAKE PADS		6215034 2007-> € 18,62 6215010 1996->06 € 18,75	6215010 € 18,75 1998->	6215010 € 18,75	-
	BRAKE PADS REAR ORGANIC BRAKE PADS		-	-	-	-
	BRAKE PADS MHR REAR ORGANIC BRAKE PADS		-	-	-	-
	BRAKE PADS MHR SYNT REAR SINTERED BRAKE PADS		6215018 € 15,60 2001->	6215018 € 15,60 2001->	-	-
	BRAKE POWER REAR BRAKE SHOES		-	-	-	-
	DISC / WHOOP DISC / PAIR WHOOP FRONT BRAKE DISC		6212344 € 94,00 1998->	6212344 € 94,00 1999->	-	-
	DISC / WHOOP DISC REAR BRAKE DISC		-	-	-	-
	TWINS MAXI SUSPENSIONS REAR PAIR SHOCK ABSORBER		-	-	-	-
	RS3 - RS1 REAR SHOCK ABSORBER		-	-	-	-
	RS24 REAR SHOCK ABSORBER		-	-	-	-
	RS24 FRONT SHOCK ABSORBER		-	-	-	-
	RS24 FRONT + REAR		-	-	-	-
	F32S FORK STEMS Ø 32		-	-	-	-
	F37R FORK STEMS Ø 37		-	-	-	-

11 - for VEHICLE with Front DOUBLE DISC

SUZUKI						SYM	
BURGMAN AN K10 > ie	BURGMAN AN	EPICURO	EPICURO	SIXTEEN euro 3	SIXTEEN euro 3	CITYCOM euro 3	EURO MX
				(F499)	(G421)	(LEA 1)	
400 4T LC	650 4T LC	125 4T LC	150 4T LC	125 4T LC	150 4T LC	300 4T LC	125 4T LC
-	-	-	-	-	-	-	-
-	3212725 € 539,67	-	-	-	-	-	-
3214834 € 380,00	-	-	-	-	-	-	-
0313379 € 3,38	-	0313379 € 3,38	0313379 € 3,38	-	-	-	-
-	-	-	-	-	-	-	-
-	-	-	-	-	-	-	-
-	-	-	-	-	-	-	-
-	-	-	-	-	-	-	-
-	-	-	-	-	-	-	-
-	-	-	-	-	-	-	-
-	-	-	-	-	-	-	-
-	-	-	-	-	-	-	-
-	6216890 *11* € 9,87	6212165 € 16,50 1998->	6212165 € 16,50 1998->	-	-	6215856 € 7,80 2010->	-
-	-	6212166 € 16,50 1998->	6212166 € 16,50 1998->	-	-	-	-
-	6215027 *11* € 16,64	-	-	6215034 € 18,62	6215034 € 18,62	-	-
-	-	6212165 € 16,50 2001->	6212165 € 16,50 2001->	-	-	-	-
-	-	6212166 € 16,50 2001->	6212166 € 16,50 2001->	-	-	-	-
-	-	-	-	-	-	-	-
-	-	-	-	-	-	-	-
-	-	-	-	-	-	-	-
-	-	-	-	-	-	-	-
-	-	-	-	-	-	-	-
-	-	-	-	-	-	-	-
-	-	-	-	-	-	-	-
-	-	-	-	-	-	-	-
-	-	-	-	-	-	-	-
-	-	-	-	-	-	-	-
-	-	-	-	-	-	-	-
-	-	-	-	-	-	-	-
-	-	-	-	-	-	-	-
-	-	-	-	-	-	-	-



MALOSS

Maxi Scooter

125 → 800 4T

with ENGINE 

SYM

FIDDLE 2
euro 3GTS
euro 3GTS I
ie euro 3GTS Evo I
ie euro 3

(MK8)

125 4T



125 4T

LC

250 4T

LC

300 4T

LC

Products to be used exclusively for racing in places specially designed for such activity according to the regulations of the competent sporting authorities. We accept no liability resulting from improper use.

	CYLINDER 4 STROKE ALUMINIUM	-	-	-	-
	CYLINDER I-TECH ALUMINIUM EQUIPPED WITH CDI	-	-	-	-
	POWER CAM CAMSHAFT	-	-	-	-
	HEAD V4 HEAD FOR ORIGINAL CYLINDER / MALOSS	-	-	-	-
	CYLINDER + V4 HEAD ALUMINIUM	-	-	-	-
	CYLINDER + V4 HEAD + POWER CAM ALUMINIUM Ø 75,5	-	-	-	-
	4 STROKE VALVE FOR ENGINE VALVES SET	-	-	-	-
	SPRINGS FOR ENGINE VALVES	-	-	-	-
	CRANKSHAFT RHQ	-	-	-	-
	IGNITION CONTROLLER DIGITRONIC FOR VEHICLES WITHOUT IMMOBILIZER	-	-	-	-
	IGNITION CONTROLLER DIGITRONIC FOR VEHICLES WITH IMMOBILIZER	-	-	-	-
	FORCE MASTER INJECTION CONTROLLER	-	-	-	-
	TC UNIT O2 controller LAMBDA EMULATOR	-	-	-	-
	MULTIVAR 2000 VARIATOR	5113813	5114273	5113597	5113597
	MULTIVAR 2000 MHR	€ 112,35	€ 112,35	€ 136,15	€ 136,15
	X SPECIAL BELT BELT	-	-	-	-
	X K BELT BELT	-	-	-	-
	HTRoll	6611095.M0	6611095.M0	66 9917.Q0	66 9917.Q0
	ROLLERS FOR MULTIVAR 2000 / MHR	€ 13,64 gr.11,5	€ 13,64 gr.11,5	€ 19,12 gr.20	€ 19,12 gr.20
	HTRoll	6614705.F0	6614705.B0	-	-
	ROLLERS FOR ORIGINAL VARIATOR	€ 16,50 gr.14	€ 16,50 gr.10	-	-
	VENTILVAR 2000 FIXED HALF-PULLEY	-	-	-	-
	VARIABLE-SPEED DRIVE ADJUSTER SPRING PG. 445	PG.445	2911266.Y0 *PG* € 10,71	2911074.Y0 *PG* € 10,71	2911074.Y0 *PG* € 10,71
	TORSION CONTROLLER ANTIFRICTION FIFTH WHEEL	-	-	-	-
	TORQUE DRIVER MOBILE DRIVEN SPLIT PULLEY	-	-	-	-
	OVER RANGE TRANSMISSION KIT	-	-	-	-
	MAXI FLY CLUTCH NOT ADJUSTABLE CLUTCH	-	-	-	-
	MAXI DELTA CLUTCH ADJUSTABLE CLUTCH	-	-	5211835 € 128,41	5211835 € 128,41
	MAXI CLUTCH BELL CLUTCH BELL (SMOOTH RING)	-	-	-	-
	MAXI WING CLUTCH BELL CLUTCH BELL (FINNED RING)	-	-	-	-
	MAXI FLY SYSTEM CLUTCH BELL + NOT ADJUSTABLE CLUTCH	-	-	-	-
	MAXI DELTA SYSTEM CLUTCH BELL + ADJUSTABLE CLUTCH	-	-	-	-
	SPRINGS FOR MAXI FLY CLUTCH	-	-	-	-
	SPRINGS FOR MAXI DELTA CLUTCH	-	-	2911848 € 17,00	2911848 € 17,00
	SPRINGS FOR ORIGINAL CLUTCH	-	-	2911848 € 17,00	2911848 € 17,00

PG - SPECIFICATIONS on the PAGE indicated in the TITLE of the LINE

SYM

HD Evo I ie euro 3	HD Evo I ie euro 3	JOYMAX I ie euro 3	JOYMAX I ie euro 3	JOYMAX Evo I ie euro 3	JOYRIDE	JOYRIDE Evo I ie	SUPER Duke
	(HHA-1)	(HMA-1)	(MK915096)	(MK8)		(KB2)	
125 4T LC	200 4T LC	250 4T LC	300 4T LC	300 4T LC	150 4T LC	200 4T LC	150 4T 
-	-	-	-	-	-	-	-
-	-	-	-	-	-	-	-
-	-	-	-	-	-	-	-
-	-	-	-	-	-	-	-
-	-	-	-	-	-	-	-
-	-	-	-	-	-	-	-
-	-	-	-	-	-	-	-
-	-	-	-	-	-	-	-
-	-	-	-	-	-	-	-
-	-	-	-	-	-	-	-
-	-	-	-	-	-	-	-
-	-	-	-	-	-	-	-
-	-	-	-	-	-	-	-
-	-	-	-	-	-	-	-
-	-	-	-	-	-	-	-
5114273 € 112,35	5111260 € 112,35	5113597 € 136,15	5113597 € 136,15	5113597 € 136,15	5111869 € 112,35	5111260 € 112,35	5111577 € 107,45
-	-	-	-	-	-	61 9221 € 18,68 61 9463 € 28,02	-
6611095.M0 € 13,64 gr.11,5	6611095.Q0 € 13,64 gr.13,5	66 9917.Q0 € 19,12 gr.20	66 9917.Q0 € 19,12 gr.20	66 9917.Q0 € 19,12 gr.20	6611095.I0 € 13,64	6611095.Q0 € 13,64 gr.13,5	6611095.I0 € 13,64
6614705.B0 € 16,50 gr.10	-	-	-	-	6611534.D0 € 11,00 gr.13,5	-	-
-	-	-	-	-	-	-	-
2911266.Y0 *PG* € 10,71	-	2911074.Y0 *PG* € 10,71	2911074.Y0 *PG* € 10,71	2911074.Y0 *PG* € 10,71	-	-	2911266.Y0 *PG* € 10,71
-	-	-	-	-	-	-	-
-	-	-	-	-	-	-	-
5212522 € 70,37	-	-	-	-	-	-	-
5212487 € 112,59	-	5211835 € 128,41	5211835 € 128,41	5211835 € 128,41	-	-	-
-	7714325 € 33,00 Ø 125	-	-	-	7714325 € 33,00 Ø 125	7714325 € 33,00 Ø 125	-
7713376 € 38,00 Ø 125	-	-	-	-	-	-	-
-	-	-	-	-	-	-	-
5216070 € 125,46 Ø 125	-	-	-	-	-	-	-
29 9605 € 16,20	-	-	-	-	-	-	-
29 9605 € 16,20	-	2911848 € 17,00	2911848 € 17,00	2911848 € 17,00	-	-	-
29 9605 € 16,20	2912536 € 15,56	2911848 € 17,00	2911848 € 17,00	2911848 € 17,00	-	2914202 € 15,04	-

MAXI SCOOTER 125 → 800 4T



MALOSSI

Maxi Scooter

125 → 800 4T

with ENGINE 

SYM

FIDDLE 2
euro 3GTS
euro 3GTS I
euro 3GTS Evo I
euro 3

(LEA 1)

() CHECK "TYPE" SPECIFICATION (HOMOLOGATION MARK).

125 4T



125 4T















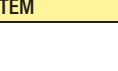













LC

250 4T

LC

300 4T

LC

	CLUTCH DISK SET FOR ORIGINAL CLUTCH		-	-	-	-
	MAXI WILD LION  HOMOLOGATED EXHAUST SYSTEM	 PG. 418	-	-	-	-
	RX  HOMOLOGATED EXHAUST SYSTEM	 PG. 420	-	-	-	-
	RED CHILLI OIL OIL FILTER		-	-	-	-
	RED SPONGE FOR ORIGINAL AIR BOX		-	-	-	-
	DOUBLE RED SPONGE FOR ORIGINAL AIR BOX		-	-	-	-
	W BOX FOR ORIGINAL AIR BOX		-	-	-	-
	V FILTER VARIATOR AIR FILTER RIGHT SIDE		-	-	-	-
	POWER TRASMISSION		-	-	-	-
	GEARS HTQ PRIMARY		-	-	-	-
	GEARS HTQ SECONDARY		-	-	-	-
	SPORT SCREEN SCREEN		-	-	-	-
	MHR SCREEN SCREEN		-	-	-	-
	HOSE KIT FOR BRAKE		-	-	-	-
	BRAKE PADS FRONT ORGANIC BRAKE PADS	6215856 € 7,80 2008->10	-	-	-	-
	BRAKE PADS MHR FRONT ORGANIC BRAKE PADS		-	-	-	-
	BRAKE PADS MHR SYNT FRONT SINTERED BRAKE PADS		-	-	-	-
	BRAKE PADS REAR ORGANIC BRAKE PADS		-	-	-	-
	BRAKE PADS MHR REAR ORGANIC BRAKE PADS		-	-	-	-
	BRAKE PADS MHR SYNT REAR SINTERED BRAKE PADS		-	-	-	-
	BRAKE POWER REAR BRAKE SHOES		-	-	-	-
	DISC / WHOOP DISC / PAIR WHOOP FRONT BRAKE DISC		-	-	-	-
	DISC / WHOOP DISC REAR BRAKE DISC		-	-	-	-
	TWINS MAXI SUSPENSIONS REAR PAIR SHOCK ABSORBER		-	-	-	-
	RS3 - RS1 REAR SHOCK ABSORBER		-	-	-	-
	RS24 REAR SHOCK ABSORBER		-	-	-	-
	RS24 FRONT SHOCK ABSORBER		-	-	-	-
	RS24 FRONT + REAR		-	-	-	-
	F32S FORK STEMS Ø 32		-	-	-	-
	F37R FORK STEMS Ø 37		-	-	-	-







MALOSSI

Maxi Scooter

125 → 800 4T

with ENGINE 

SYM	TGB	VESPA	
SYMPHONY S euro 3	X MOTION	946 3V ABS ie	ET4
(XS1P52QMI-4)		(M801M)	
125 4T 	250 4T 	LC 125 4T 	125 4T 

Products to be used exclusively for racing in places specially designed for such activity according to the regulations of the competent sporting authorities. We accept no liability resulting from improper use.

	CYLINDER 4 STROKE ALUMINIUM	-	-	-	31 9518 € 295,92 Ø 60
	CYLINDER I-TECH ALUMINIUM EQUIPPED WITH CDI	-	-	3116669 € 530,45 Ø 63	-
	POWER CAM CAMSHAFT	-	-	-	-
	HEAD V4 HEAD FOR ORIGINAL CYLINDER / MALOSSI	-	-	-	-
	CYLINDER + V4 HEAD ALUMINIUM	-	-	-	-
	CYLINDER + V4 HEAD + POWER CAM ALUMINIUM Ø 75,5	-	-	-	-
	4 STROKE VALVE FOR ENGINE VALVES SET	-	-	-	-
	SPRINGS FOR ENGINE VALVES	-	-	-	-
	CRANKSHAFT RHQ	-	-	-	-
	IGNITION CONTROLLER DIGITRONIC FOR VEHICLES WITHOUT IMMOBILIZER	-	-	-	-
	IGNITION CONTROLLER DIGITRONIC FOR VEHICLES WITH IMMOBILIZER	-	-	-	-
	FORCE MASTER INJECTION CONTROLLER	-	-	-	-
	TC UNIT O2 controller LAMBDA EMULATOR	-	-	5515735 € 88,00	-
	MULTIVAR 2000 VARIATOR MULTIVAR 2000 MHR	5114273 € 112,35	5113597 € 136,15	5115639 € 112,35	5111154 € 75,99
	X SPECIAL BELT BELT X K BELT BELT	-	-	6116117 € 34,27	6111153 € 28,25
	HTRoll ROLLERS FOR MULTIVAR 2000 / MHR	6611095.M0 € 13,64 gr.11,5	66 9917.Q0 € 19,12 gr.20	6611095.F0 € 13,64 gr.09	66 9420.K0 € 10,00 gr.12
	HTRoll ROLLERS FOR ORIGINAL VARIATOR	6614705.B0 € 16,50 gr.10	-	66 9456.H0 € 12,00 gr.10	6611531.H0 € 9,41 gr.12
	VENTILVAR 2000 FIXED HALF-PULLEY	-	-	-	-
	VARIABLE-SPEED DRIVE ADJUSTER SPRING FOR VARIATOR	PG. 445 2911266.Y0 *PG* € 10,71	2911074.Y0 *PG* € 10,71	PG.445	-
	TORSION CONTROLLER ANTIFRICTION FIFTH WHEEL	-	-	2513210 € 5,72	-
	TORQUE DRIVER MOBILE DRIVEN SPLIT PULLEY	-	-	-	-
	OVER RANGE TRANSMISSION KIT	-	-	-	-
	MAXI FLY CLUTCH NOT ADJUSTABLE CLUTCH	5212522 € 70,37	-	-	-
	MAXI DELTA CLUTCH ADJUSTABLE CLUTCH	5212487 € 112,59	5211835 € 128,41	5216462 € 120,42	-
	MAXI CLUTCH BELL CLUTCH BELL (SMOOTH RING)	-	-	7715647 € 43,00 Ø 134	-
	MAXI WING CLUTCH BELL CLUTCH BELL (FINNED RING)	7713376 € 38,00 Ø 125	-	-	-
	MAXI FLY SYSTEM CLUTCH BELL + NOT ADJUSTABLE CLUTCH	-	-	-	-
	MAXI DELTA SYSTEM CLUTCH BELL + ADJUSTABLE CLUTCH	5216070 € 125,46 Ø 125	-	5216569 € 135,00 Ø 134	-
	SPRINGS FOR MAXI FLY CLUTCH	29 9605 € 16,20	-	-	-
	SPRINGS FOR MAXI DELTA CLUTCH	29 9605 € 16,20	2911848 € 17,00	-	-
	SPRINGS FOR ORIGINAL CLUTCH	29 9605 € 16,20	2911848 € 17,00	2911326 € 17,00	-

01 - TO COUPLE ONLY with MALOSSI CYLINDERS: 3813273 € 475,00

62 - TO COUPLE ONLY with MALOSSI CYLINDERS : 5911962 € 218,53

PG - SPECIFICATIONS on the PAGE indicated in the TITLE of the LINE

TEC1 ** ATTENTION ** PLEASE CHECK THE PROPER FITMENT : PAGE 416

VESPA

175

ET4	ET4	Granturismo L - GT	Granturismo L - GT	GTS euro 3	GTS Super ie euro 3 <-2013	GTS Super ie euro 3 2014 ->	GTS ie
(LEADER)	(LEADER)	(LEADER)	(M312M)	(M315M)	(M455M)		
125 4T	150 4T	125 4T	200 4T	125 4T	125 4T	125 4T	250 4T
		LC	LC	LC	LC	LC	LC
3111393 €302,60 Ø 70	3111393 €302,60 Ø 70	3113955 €335,00 Ø 75,5	3113955 €335,00 Ø 75,5	3113955 €335,00 Ø 75,5	-	-	3113928 €335,00 Ø 74
-	-	-	-	-	3116090 €520,00 Ø 75,5	3116090 €520,00 Ø 75,5	-
-	-	*62*	5911962 €218,53	*62*	*TEC1*	-	-
-	-	*01*	*01*	*01*	*TEC1*	*01*	3813273 €475,00
-	-	-	-	-	-	-	3113927 €745,00 Ø 74
-	-	3116208 €895,00	3116208 €895,00	3116208 €895,00	*TEC1*	-	-
-	-	2714047 €118,53	2714047 €118,53	2714047 €118,53	2714047 €118,53	2714047 €118,53	2714047 €118,53
-	-	2912834 €21,54	2912834 €21,54	2912834 €21,54	2912834 €21,54	2912834 €21,54	2912834 €21,54
-	-	5312853 €380,00	5312896 €380,00	5312853 €380,00	-	-	-
-	-	5512524 €170,46	5512524 €170,46	5512524 €170,46	-	-	-
-	-	5512341 €170,46	5512341 €170,46	5512341 €170,46	-	-	-
-	-	-	-	-	-	-	5515724 €255,84
-	-	-	-	-	5514746 €90,00	5514746 €90,00	5514749 €84,00
5111397 €112,35	5111397 €112,35	5111397 €112,35	5111885 €112,35	5111397 €112,35	5111397 €112,35	5111397 €112,35	5111885 €112,35
6116117 €34,27	6116117 €34,27	6116117 €34,27	6115666 €46,92	6116117 €34,27	6116117 €34,27	6116117 €34,27	6113027 €59,12
6611095.G0 €13,64 gr.09,5	6611095.R0 €13,64 gr.14	6611095.G0 €13,64 gr.09,5	6611095.R0 €13,64 gr.14	6611095.G0 €13,64 gr.09,5	6611095.G0 €13,64 gr.09,5	6611095.G0 €13,64 gr.09,5	6611095.T0 €13,64 gr.15
66 9456.F0 €12,00 gr.08,7	66 9456.H0 €12,00 gr.10	66 9456.D0 €12,00 gr.07,4	6611095.O0 €13,64 gr.12,5	66 9456.D0 €12,00 gr.07,4	66 9456.D0 €12,00 gr.07,4	66 9456.D0 €12,00 gr.07,4	-
-	-	-	-	-	-	-	-
PG.445	PG.445	PG.445	PG.445	PG.445	PG.445	PG.445	PG.445
2513210 €5,72	2513210 €5,72	2513210 €5,72	2513210 €5,72	2513210 €5,72	2513210 €5,72	2513210 €5,72	2513210 €5,72
6111656 €123,88	6111656 €123,88	6111656 €123,88	6112563 €197,30	6111656 €123,88	6111656 €123,88	6111656 €123,88	6112563 €197,30
-	-	-	-	-	-	-	-
-	-	-	-	-	-	-	-
5211821 €120,42	5211821 €120,42	5211821 €120,42	5211821 €120,42	5211821 €120,42	5211821 €120,42	5211821 €120,42	5211821 €120,42
-	-	-	-	-	-	-	-
7715898B €52,00 Ø 134	7715898B €52,00 Ø 134	7715898B €52,00 Ø 134	7715898B €52,00 Ø 134	7715898B €52,00 Ø 134	7715898B €52,00 Ø 134	7715898B €52,00 Ø 134	7715898B €52,00 Ø 134
-	-	-	-	-	-	-	-
5216918 €136,00 Ø 134	5216918 €136,00 Ø 134	5216918 €136,00 Ø 134	5216918 €136,00 Ø 134	5216918 €136,00 Ø 134	5216918 €136,00 Ø 134	5216918 €136,00 Ø 134	5216918 €136,00 Ø 134
-	-	-	-	-	-	-	-
2911326 €17,00	2911326 €17,00	2911326 €17,00	2911326 €17,00	2911326 €17,00	2911326 €17,00	2911326 €17,00	2911326 €17,00
2911326 €17,00	2911326 €17,00	2911326 €17,00	2911326 €17,00	2911326 €17,00	2911326 €17,00	2911326 €17,00	2911326 €17,00

MAXI SCOOTER 125 → 800 4T



MALOSSİ

Maxi Scooter

125 → 800 4T

with ENGINE

SYM
TGB
VESPA

 SYMPHONY S
euro 3

X MOTION

 946 3V ABS
ie

ET4

(XS1P52QMI-4)

(M801M)

125 4T



250 4T

LC

125 4T



125 4T



() CHECK "TYPE" SPECIFICATION (HOMOLOGATION MARK).

	CLUTCH DISK SET FOR ORIGINAL CLUTCH		-	-	-	-
	MAXI WILD LION HOMOLOGATED EXHAUST SYSTEM		-	-	-	-
	RX HOMOLOGATED EXHAUST SYSTEM		-	-	-	-
	RED CHILLI OIL OIL FILTER		-	-	0313382 € 7,00	0313381 € 3,80
	RED SPONGE FOR ORIGINAL AIR BOX		-	-	-	1411425 € 4,45 1996/98
	DOUBLE RED SPONGE FOR ORIGINAL AIR BOX		-	-	-	1414503 € 6,65 1996/98
	W BOX FOR ORIGINAL AIR BOX		-	-	-	-
	V FILTER VARIATOR AIR FILTER RIGHT SIDE		-	-	-	-
	POWER TRASMISSION		-	-	-	-
	GEARS HTQ PRIMARY		-	-	-	-
	GEARS HTQ SECONDARY		-	-	-	PG.478
	SPORT SCREEN SCREEN		-	-	-	-
	MHR SCREEN SCREEN		-	-	-	-
	HOSE KIT FOR BRAKE		-	-	-	-
	BRAKE PADS FRONT ORGANIC BRAKE PADS		6215856 € 7,80 2010->	-	6215062 € 8,32	6215049 € 6,24 1996->
	BRAKE PADS MHR FRONT ORGANIC BRAKE PADS		-	-	6215079 € 8,20	6215074 € 6,30 1996->
	BRAKE PADS MHR SYNT FRONT SINTERED BRAKE PADS		-	-	6215013 € 16,50	6215006 € 11,96 1996->
	BRAKE PADS REAR ORGANIC BRAKE PADS		6215049 € 6,24	-	-	-
	BRAKE PADS MHR REAR ORGANIC BRAKE PADS		6215074 € 6,30	-	-	-
	BRAKE PADS MHR SYNT REAR SINTERED BRAKE PADS		6215006 € 11,96	-	6215015 € 16,64	-
	BRAKE POWER REAR BRAKE SHOES		-	-	-	6215328 € 18,39 1996->
	DISC / WHOOP DISC / PAIR WHOOP FRONT BRAKE DISC		-	-	-	6212604 € 76,38 1996->
	DISC / WHOOP DISC REAR BRAKE DISC		-	-	-	-
	TWINS MAXI SUSPENSIONS REAR PAIR SHOCK ABSORBER		-	-	-	-
	RS3 - RS1 REAR SHOCK ABSORBER		-	-	-	46 7908 € 140,92 4615432 € 94,86
	RS24 REAR SHOCK ABSORBER		-	-	-	46 8308 € 248,50
	RS24 FRONT SHOCK ABSORBER		-	-	4614137 € 178,50	46 7900 € 222,63
	RS24 FRONT + REAR		-	-	-	46 9031 € 456,47
	F32S FORK STEMS Ø 32		-	-	-	-
	F37R FORK STEMS Ø 37		-	-	-	-

VESPA

ET4	ET4	Granturismo L - GT	Granturismo L - GT	GTS euro 3	GTS Super ie euro 3 <-2013	GTS Super ie euro 3 2014 ->	GTS ie						
(LEADER)	(LEADER)	(LEADER)	(M312M)	(M315M)	(M455M)								
125 4T	150 4T	125 4T	LC	200 4T	LC	125 4T	LC	125 4T	LC	125 4T	LC	250 4T	LC
-	-	-	-	-	-	-	-	-	-	-	-	-	-
-	-	-	-	-	-	-	-	-	-	-	-	-	-
-	-	-	-	3216703 BLACK € 502,00	-	3216703 BLACK € 502,00	3216703 BLACK € 502,00	3216703 BLACK € 502,00	-	-	-	-	-
-	-	-	-	3214824 € 356,50	-	3214824 € 356,50	3214824 € 356,50	3214824 € 356,50	-	-	-	-	-
0313382	0313382	0313382	0313382	0313382	0313382	0313382	0313382	0313382	0313382	0313382	0313382	0313382	0313382
€ 7,00	€ 7,00	€ 7,00	€ 7,00	€ 7,00	€ 7,00	€ 7,00	€ 7,00	€ 7,00	€ 7,00	€ 7,00	€ 7,00	€ 7,00	€ 7,00
-	-	1413811	1413811	1413811	1413811	1413811	1413811	1413811	1413811	1413811	1413811	1413811	1413811
-	-	€ 5,84	€ 5,84	€ 5,84	€ 5,84	€ 5,84	€ 5,84	€ 5,84	€ 5,84	€ 5,84	€ 5,84	€ 5,84	€ 5,84
-	-	1414486	1414486	1414486	1414486	1414486	1414486	1414486	1414486	1414486	1414486	1414486	1414486
-	-	€ 7,02	€ 7,02	€ 7,02	€ 7,02	€ 7,02	€ 7,02	€ 7,02	€ 7,02	€ 7,02	€ 7,02	€ 7,02	€ 7,02
-	-	-	-	-	-	-	-	-	-	-	-	-	-
-	-	-	-	-	-	-	-	-	-	-	-	-	-
-	-	-	-	-	-	-	-	-	-	-	-	-	-
-	-	-	-	-	-	-	-	-	-	-	-	-	-
6711860	-	6711860	6711860	6711860	6711860	6712194	6712194	6712194	6712194	6712194	6712194	-	-
€ 60,41 z 16/42	-	€ 60,41 z 16/42	€ 60,41 z 16/42	€ 60,41 z 16/42	€ 60,41 z 16/42	€ 92,98 z 17/49	€ 92,98 z 17/49	€ 92,98 z 17/49	€ 92,98 z 17/49	€ 92,98 z 17/49	€ 92,98 z 17/49	-	-
-	-	4515118	4515118	4515118	4515118	4515118	4515118	4515118	4515118	4515118	4515118	4515118	4515118
-	-	€ 67,00	€ 67,00	€ 67,00	€ 67,00	€ 67,00	€ 67,00	€ 67,00	€ 67,00	€ 67,00	€ 67,00	€ 67,00	€ 67,00
-	-	-	-	-	-	-	-	-	-	-	-	-	-
6215049	6215049	-	-	-	-	6215062	6215062	6215062	6215062	6215062	6215062	6215062	6215062
€ 6,24 1999->	€ 6,24 1999->	-	-	-	-	€ 8,32	€ 8,32	€ 8,32	€ 8,32	€ 8,32	€ 8,32	€ 8,32	€ 8,32
6215074	6215074	-	-	-	-	6215079	6215079	6215079	6215079	6215079	6215079	6215079	6215079
€ 6,30 1999->	€ 6,30 1999->	-	-	-	-	€ 8,20	€ 8,20	€ 8,20	€ 8,20	€ 8,20	€ 8,20	€ 8,20	€ 8,20
6215006	6215006	-	-	-	-	6215013	6215013	6215013	6215013	6215013	6215013	6215013	6215013
€ 11,96 1999->	€ 11,96 1999->	-	-	-	-	€ 16,50	€ 16,50	€ 16,50	€ 16,50	€ 16,50	€ 16,50	€ 16,50	€ 16,50
-	-	-	-	-	-	-	-	-	-	-	-	-	-
-	-	-	-	-	-	-	-	-	-	-	-	-	-
-	-	-	-	-	-	6215015	6215015	6215015	6215015	6215015	6215015	-	-
-	-	-	-	-	-	€ 16,64	€ 16,64	€ 16,64	€ 16,64	€ 16,64	€ 16,64	-	-
-	-	-	-	-	-	-	-	-	-	-	-	-	-
6212604	6212604	6215330	6215330	6215330	6215330	6215330	6215330	6215330	6215330	6215330	6215330	6215330	6215330
€ 76,38 1999->	€ 76,38 1999->	€ 80,00	€ 80,00	€ 80,00	€ 80,00	€ 80,00	€ 80,00	€ 80,00	€ 80,00	€ 80,00	€ 80,00	€ 80,00	€ 80,00
-	-	6215330	6215330	6215330	6215330	6215330	6215330	6215330	6215330	6215330	6215330	6215330	6215330
-	-	€ 80,00	€ 80,00	€ 80,00	€ 80,00	€ 80,00	€ 80,00	€ 80,00	€ 80,00	€ 80,00	€ 80,00	€ 80,00	€ 80,00
-	-	4613185	4613185	4613185	4613185	4613185	4613185	4613185	4613185	4613185	4613185	4613185	4613185
-	-	€ 248,00	€ 248,00	€ 248,00	€ 248,00	€ 248,00	€ 248,00	€ 248,00	€ 248,00	€ 248,00	€ 248,00	€ 248,00	€ 248,00
-	-	-	-	-	-	-	-	-	-	-	-	-	-
-	-	-	-	-	-	-	-	-	-	-	-	-	-
46 7900	46 7900	4614137	4614137	4614137	4614137	4614137	4614137	4614137	4614137	4614137	4614137	4614137	4614137
€ 222,63	€ 222,63	€ 178,50	€ 178,50	€ 178,50	€ 178,50	€ 178,50	€ 178,50	€ 178,50	€ 178,50	€ 178,50	€ 178,50	€ 178,50	€ 178,50
-	-	-	-	-	-	-	-	-	-	-	-	-	-
-	-	-	-	-	-	-	-	-	-	-	-	-	-
-	-	-	-	-	-	-	-	-	-	-	-	-	-
-	-	-	-	-	-	-	-	-	-	-	-	-	-



MALOSSI

Maxi Scooter

125 → 800 4T

with ENGINE



VESPA

GTS Super
ie euro 3
<-2013GTS Super
ie euro 3
2014->

GTV

GTV
ie

(QUASAR M454M)

(QUASAR M454M)

(LEADER)

300 4T

LC

300 4T

LC

125 4T

LC

250 4T

LC

	CYLINDER 4 STROKE ALUMINIUM	3113958 € 335,00 Ø 75,5	3113958 € 335,00 Ø 75,5	3113955 € 335,00 Ø 75,5	3113928 € 335,00 Ø 74	
	CYLINDER I-TECH ALUMINIUM EQUIPPED WITH CDI	-	-	-	-	
	POWER CAM CAMSHAFT	-	-	*62*	-	
	HEAD V4 HEAD FOR ORIGINAL CYLINDER / MALOSSİ	3813273 € 475,00	3813273 € 475,00	*01*	3813273 € 475,00	
	CYLINDER + V4 HEAD ALUMINIUM	3114700 € 745,00 Ø 75,5	3114700 € 745,00 Ø 75,5	-	3113927 € 745,00 Ø 74	
	CYLINDER + V4 HEAD + POWER CAM ALUMINIUM Ø 75,5	-	-	3116208 € 895,00	-	
	4 STROKE VALVE FOR ENGINE VALVES SET	2714047 € 118,53	2714047 € 118,53	2714047 € 118,53	2714047 € 118,53	
	SPRINGS FOR ENGINE VALVES	2912834 € 21,54	2912834 € 21,54	2912834 € 21,54	2912834 € 21,54	
	CRANKSHAFT RHQ	-	-	5312853 € 380,00	-	
	IGNITION CONTROLLER DIGITRONIC FOR VEHICLES WITHOUT IMMOBILIZER	-	-	5512524 € 170,46	-	
	IGNITION CONTROLLER DIGITRONIC FOR VEHICLES WITH IMMOBILIZER	-	-	5512341 € 170,46	-	
	FORCE MASTER INJECTION CONTROLLER	5514780 € 255,84	5514780 € 255,84	-	5515724 € 255,84	
	TC UNIT O2 controller LAMBDA EMULATOR	5514746 € 90,00	5514746 € 90,00	-	5514749 € 84,00	
		MULTIVAR 2000 VARIATOR MULTIVAR 2000 MHR	5111885 € 112,35	5111885 € 112,35	5111397 € 112,35	5111885 € 112,35
		X SPECIAL BELT BELT X K BELT BELT	6113027 € 59,12	6113027 € 59,12	6116117 € 34,27	6113027 € 59,12
HTRoll ROLLERS FOR MULTIVAR 2000 / MHR		6611095.TO € 13,64 gr.15	6611095.TO € 13,64 gr.15	6611095.G0 € 13,64 gr.09,5	6611095.TO € 13,64 gr.15	
	HTRoll ROLLERS FOR ORIGINAL VARIATOR	-	-	66 9456.D0 € 12,00 gr.07,4	-	
	VENTILVAR 2000 FIXED HALF-PULLEY	-	-	-	-	
	VARIABLE-SPEED DRIVE ADJUSTER SPRING FOR VARIATOR	PG.445	PG.445	PG.445	PG.445	
	TORSION CONTROLLER ANTIFRICTION FIFTH WHEEL	2513210 € 5,72	2513210 € 5,72	2513210 € 5,72	2513210 € 5,72	
	TORQUE DRIVER MOBILE DRIVEN SPLIT PULLEY	6112563 € 197,30	6112563 € 197,30	6111656 € 123,88	6112563 € 197,30	
	OVER RANGE TRANSMISSION KIT	-	-	-	-	
	MAXI FLY CLUTCH NOT ADJUSTABLE CLUTCH	-	-	-	-	
	MAXI DELTA CLUTCH ADJUSTABLE CLUTCH	5211821 € 120,42	5211821 € 120,42	5211821 € 120,42	5211821 € 120,42	
	MAXI CLUTCH BELL CLUTCH BELL (SMOOTH RING)	-	-	-	-	
	MAXI WING CLUTCH BELL CLUTCH BELL (FINNED RING)	7715898B € 52,00 Ø 134	7715898B € 52,00 Ø 134	7715898B € 52,00 Ø 134	7715898B € 52,00 Ø 134	
	MAXI FLY SYSTEM CLUTCH BELL + NOT ADJUSTABLE CLUTCH	-	-	-	-	
	MAXI DELTA SYSTEM CLUTCH BELL + ADJUSTABLE CLUTCH	5216918 € 136,00 Ø 134	5216918 € 136,00 Ø 134	5216918 € 136,00 Ø 134	5216918 € 136,00 Ø 134	
	SPRINGS FOR MAXI FLY CLUTCH	-	-	-	-	
	SPRINGS FOR MAXI DELTA CLUTCH	2911326 € 17,00	2911326 € 17,00	2911326 € 17,00	2911326 € 17,00	
	SPRINGS FOR ORIGINAL CLUTCH	2911326 € 17,00	2911326 € 17,00	2911326 € 17,00	2911326 € 17,00	

01 - TO COUPLE ONLY with MALOSSİ CYLINDERS: 3813273 € 475,00

10 - ATTENTION * ONLY FOR vehicles CIRCULATING in: INDONESIA - SINGAPORE - THAILAND - VIETNAM: 7715648 € 38,00

62 - TO COUPLE ONLY with MALOSSİ CYLINDERS : 5911962 € 218,53

TEC2 ** ATTENTION ** PLEASE CHECK THE PROPER FITMENT : PAGE 414

VESPA

GTV ie euro 3	LX	LX ie euro 3	LX 3V ie euro 3 2012->	LX	LX ie euro 3	LX 3V ie euro 3 2012->	LXV ie euro 3
(QUASAR)	(LEADER)	(LEADER)	(M687M)	(LEADER)	(LEADER)	(M688M)	(LEADER)
300 4T LC	125 4T	125 4T	125 4T	150 4T	150 4T	150 4T	125 4T
3113958 €335,00 Ø 75,5	3111393 €302,60 Ø 70	-	-	3111393 €302,60 Ø 70	-	-	-
-	-	3114621 €509,85 Ø 70	*TEC2*	-	3114621 €509,85 Ø 70	*TEC2*	3114621 €509,85 Ø 70
-	-	-	-	-	-	-	-
3813273 €475,00	-	-	-	-	-	-	-
3114700 €745,00 Ø 75,5	-	-	-	-	-	-	-
-	-	-	-	-	-	-	-
2714047 €118,53	-	-	-	-	-	-	-
2912834 €21,54	-	-	-	-	-	-	-
-	-	-	-	-	-	-	-
-	-	-	-	-	-	-	-
-	-	-	-	-	-	-	-
5514780 €255,84	-	-	-	-	-	-	-
5514746 €90,00	-	5514749 €84,00	5515735 €88,00	-	5514749 €84,00	5515735 €88,00	5514749 €84,00
5111885 €112,35	5111397 €112,35	5111397 €112,35	5115639 €112,35	5111397 €112,35	5111397 €112,35	5115639 €112,35	5111397 €112,35
6113027 €59,12	6116117 €34,27	6116117 €34,27	6116117 €34,27	6116117 €34,27	6116117 €34,27	6116117 €34,27	6116117 €34,27
6611095.TO €13,64 gr.15	6611095.G0 €13,64 gr.09,5	6611095.G0 €13,64 gr.09,5	6611095.F0 €13,64 gr.09	6611095.R0 €13,64 gr.14	6611095.R0 €13,64 gr.14	6611095.Q0 €13,64 gr.13,5	6611095.G0 €13,64 gr.09,5
-	66 9456.F0 €12,00 gr.08,7	66 9456.F0 €12,00 gr.08,7	66 9456.H0 €12,00 gr.10	66 9456.H0 €12,00 gr.10	66 9456.H0 €12,00 gr.10	-	66 9456.F0 €12,00 gr.08,7
-	-	-	-	-	-	-	-
PG.445	PG.445	PG.445	PG.445	PG.445	PG.445	PG.445	PG.445
2513210 €5,72	2513210 €5,72	2513210 €5,72	2513210 €5,72	2513210 €5,72	2513210 €5,72	2513210 €5,72	2513210 €5,72
6112563 €197,30	6111656 €123,88	6111656 €123,88	-	6111656 €123,88	6111656 €123,88	-	6111656 €123,88
-	-	-	-	-	-	-	-
-	-	-	-	-	-	-	-
5211821 €120,42	5211821 €120,42	5211821 €120,42	5216462 €120,42	5211821 €120,42	5211821 €120,42	5216462 €120,42	5211821 €120,42
-	-	-	7715647 *10* €43,00 Ø 134	-	-	7715647 €43,00 Ø 134	-
7715898B €52,00 Ø 134	7715898B €52,00 Ø 134	7715898B *10* €52,00 Ø 134	-	7715898B €52,00 Ø 134	7715898B €52,00 Ø 134	-	7715898B *10* €52,00 Ø 134
-	-	-	-	-	-	-	-
5216918 €136,00 Ø 134	5216918 €136,00 Ø 134	5216918 €136,00 Ø 134	5216569 €135,00 Ø 134	5216918 €136,00 Ø 134	5216918 €136,00 Ø 134	5216569 €135,00 Ø 134	5216918 €136,00 Ø 134
-	-	-	-	-	-	-	-
2911326 €17,00	2911326 €17,00	2911326 €17,00	-	2911326 €17,00	2911326 €17,00	-	2911326 €17,00
2911326 €17,00	2911326 €17,00	2911326 €17,00	2911326 €17,00	2911326 €17,00	2911326 €17,00	2911326 €17,00	2911326 €17,00



MALOSSI

Maxi Scooter

125 → 800 4T

with ENGINE **VESPA**GTS Super
ie euro 3
<-2013GTS Super
ie euro 3
2014->

GTV

GTV
ie

(QUASAR M454M)

(QUASAR M454M)

(LEADER)

300 4T

LC

300 4T

LC











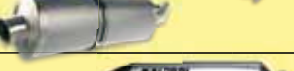

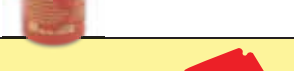















125 4T

LC

250 4T

LC

() CHECK "TYPE" SPECIFICATION (HOMOLOGATION MARK).

	CLUTCH DISK SET FOR ORIGINAL CLUTCH		-	-	-	-
	MAXI WILD LION () HOMOLOGATED EXHAUST SYSTEM	PG. 418	-	-	-	-
	RX () HOMOLOGATED EXHAUST SYSTEM	PG. 420	3216703 BLACK € 502,00 3214824 € 356,50	3216703 BLACK € 502,00 3214824 € 356,50	-	3216703 BLACK € 502,00 3214824 € 356,50
	RED CHILLI OIL OIL FILTER		0313382 € 7,00	0313382 € 7,00	0313382 € 7,00	0313382 € 7,00
	RED SPONGE FOR ORIGINAL AIR BOX		1413811 € 5,84	1413811 € 5,84	1413811 € 5,84	1413811 € 5,84
	DOUBLE RED SPONGE FOR ORIGINAL AIR BOX		1414486 € 7,02	1414486 € 7,02	1414486 € 7,02	1414486 € 7,02
	W BOX FOR ORIGINAL AIR BOX		-	-	-	-
	V FILTER VARIATOR AIR FILTER RIGHT SIDE		-	-	-	-
	POWER TRASMISSION		-	-	-	-
	GEARS HTQ PRIMARY		-	-	-	-
	GEARS HTQ SECONDARY		6714844 € 95,88 z 22/45	6714844 € 95,88 z 22/45	6711860 € 60,41 z 16/42	-
	SPORT SCREEN SCREEN		4515118 € 67,00	4515118 € 67,00	-	-
	MHR SCREEN SCREEN		-	-	-	-
	HOSE KIT FOR BRAKE		-	-	-	-
	BRAKE PADS FRONT ORGANIC BRAKE PADS		6215062 € 8,32	6215062 € 8,32	-	6215062 € 8,32
	BRAKE PADS MHR FRONT ORGANIC BRAKE PADS		6215079 € 8,20	6215079 € 8,20	-	6215079 € 8,20
	BRAKE PADS MHR SYNT FRONT SINTERED BRAKE PADS		6215013 € 16,50	6215013 € 16,50	-	6215013 € 16,50
	BRAKE PADS REAR ORGANIC BRAKE PADS		-	-	-	-
	BRAKE PADS MHR REAR ORGANIC BRAKE PADS		-	-	-	-
	BRAKE PADS MHR SYNT REAR SINTERED BRAKE PADS		-	-	-	-
	BRAKE POWER REAR BRAKE SHOES		-	-	-	-
	DISC / WHOOP DISC / PAIR WHOOP FRONT BRAKE DISC		6215330 € 80,00	6215330 € 80,00	6215330 € 80,00	6215330 € 80,00
	DISC / WHOOP DISC REAR BRAKE DISC		6215330 € 80,00	6215330 € 80,00	6215330 € 80,00	6215330 € 80,00
	TWINS MAXI SUSPENSIONS REAR PAIR SHOCK ABSORBER		4613185 € 248,00	4613185 € 248,00	4613185 € 248,00	4613185 € 248,00
	RS3 - RS1 REAR SHOCK ABSORBER		-	-	-	-
	RS24 REAR SHOCK ABSORBER		-	-	-	-
	RS24 FRONT SHOCK ABSORBER		4614137 € 178,50	-	4614137 € 178,50	4614137 € 178,50
	RS24 FRONT + REAR		-	-	-	-
	F32S FORK STEMS Ø 32		-	-	-	-
	F37R FORK STEMS Ø 37		-	-	-	-

VESPA

GTV ie euro 3	LX	LX ie euro 3	LX 3V ie euro 3 2012->	LX	LX ie euro 3	LX 3V ie euro 3 2012->	LXV ie euro 3
(QUASAR)	(LEADER)	(LEADER)	(M687M)	(LEADER)	(LEADER)	(M688M)	(LEADER)
300 4T LC	125 4T	125 4T	125 4T	150 4T	150 4T	150 4T	125 4T
-	-	-	-	-	-	-	-
-	-	-	-	-	-	-	-
3216703 BLACK € 502,00 3214824 € 356,50	-	-	-	-	-	-	-
0313382 € 7,00	0313382 € 7,00	0313382 € 7,00	0313382 € 7,00	0313382 € 7,00	0313382 € 7,00	0313382 € 7,00	0313382 € 7,00
1413811 € 5,84	-	-	1416576 € 4,20	-	-	1416576 € 4,20	-
1414486 € 7,02	1414532 € 6,70	1414532 € 6,70	-	1414532 € 6,70	1414532 € 6,70	-	1414532 € 6,70
-	-	-	-	-	-	-	-
-	-	-	-	-	-	-	-
-	-	-	-	-	-	-	-
-	-	-	-	-	-	-	-
6714844 € 95,88 z 22/45	6711860 € 60,41 z 16/42	-	-	-	-	-	-
-	4516054 € 73,80	4516054 € 73,80	4516054 € 73,80	4516054 € 73,80	4516054 € 73,80	4516054 € 73,80	-
-	-	-	-	-	-	-	-
6215062 € 8,32	6215049 € 6,24	6215049 € 6,24	6215049 € 6,24	6215049 € 6,24	6215049 € 6,24	6215049 € 6,24	6215049 € 6,24
6215079 € 8,20	6215074 € 6,30	6215074 € 6,30	6215074 € 6,30	6215074 € 6,30	6215074 € 6,30	6215074 € 6,30	6215074 € 6,30
6215013 € 16,50	6215006 € 11,96	6215006 € 11,96	6215006 € 11,96	6215006 € 11,96	6215006 € 11,96	6215006 € 11,96	6215006 € 11,96
-	-	-	-	-	-	-	-
-	-	-	-	-	-	-	-
-	-	-	-	-	-	-	-
-	-	-	-	-	-	-	-
6215330 € 80,00	6212604 € 76,38	6212604 € 76,38	6212604 € 76,38	6212604 € 76,38	6212604 € 76,38	6212604 € 76,38	6212604 € 76,38
6215330 € 80,00	-	-	-	-	-	-	-
4613185 € 248,00	4613315 € 144,00 INDIVIDUAL	4613315 € 144,00 INDIVIDUAL	4613315 € 144,00 INDIVIDUAL	4613315 € 144,00 INDIVIDUAL	4613315 € 144,00 INDIVIDUAL	4613315 € 144,00 INDIVIDUAL	4613315 € 144,00 INDIVIDUAL
-	-	-	-	-	-	-	-
-	-	-	-	-	-	-	-
4614137 € 178,50	46 7900 € 222,63	46 7900 € 222,63	46 7900 € 222,63	46 7900 € 222,63	46 7900 € 222,63	46 7900 € 222,63	46 7900 € 222,63
-	-	-	-	-	-	-	-
-	-	-	-	-	-	-	-
-	-	-	-	-	-	-	-

MAXI SCOOTER 125 → 800 4T



MALOSSI

Maxi Scooter

125 → 800 4T

with ENGINE 

VESPA

Primavera 3V
ie euro 3
2014->Primavera 3V
ie euro 3
2014->S
euro 3S 3V
ie euro 3
2012->

(M811M)

(M812M)

(LEADER M444M)

125 4T



150 4T

125 4T



125 4T



	CYLINDER 4 STROKE ALUMINIUM	-	-	3111393 € 302,60 Ø 70	-
	CYLINDER I-TECH ALUMINIUM EQUIPPED WITH CDI	*TEC2*	*TEC2*	-	3116669 € 530,45 Ø 63
	POWER CAM CAMSHAFT	-	-	-	-
	HEAD V4 HEAD FOR ORIGINAL CYLINDER / MALOSSI	-	-	-	-
	CYLINDER + V4 HEAD ALUMINIUM	-	-	-	-
	CYLINDER + V4 HEAD + POWER CAM ALUMINIUM Ø 75,5	-	-	-	-
	4 STROKE VALVE FOR ENGINE VALVES SET	-	-	-	-
	SPRINGS FOR ENGINE VALVES	-	-	-	-
	CRANKSHAFT RHQ	-	-	-	-
	IGNITION CONTROLLER DIGITRONIC FOR VEHICLES WITHOUT IMMOBILIZER	-	-	-	-
	IGNITION CONTROLLER DIGITRONIC FOR VEHICLES WITH IMMOBILIZER	-	-	-	-
	FORCE MASTER INJECTION CONTROLLER	-	-	-	-
	TC UNIT O2 controller LAMBDA EMULATOR	5515735 € 88,00	5515735 € 88,00	-	5515735 € 88,00
	MULTIVAR 2000 VARIATOR MULTIVAR 2000 MHR	5116149 € 112,35	5115639 € 112,35	5111397 € 112,35	5115639 € 112,35
	X SPECIAL BELT BELT X K BELT BELT	6116148 € 31,00	6116117 € 34,27	6116117 € 34,27	6116117 € 34,27
	HTRoll ROLLERS FOR MULTIVAR 2000 / MHR	6611095.H0 € 13,64 gr.10	6611095.Q0 € 13,64 gr.13,5	6611095.G0 € 13,64 gr.09,5	6611095.F0 € 13,64 gr.09
	HTRoll ROLLERS FOR ORIGINAL VARIATOR	6611534.D0 € 11,00 gr.13,5	6611095.T0 € 13,64 gr.15	66 9456.F0 € 12,00 gr.08,7	-
	VENTILVAR 2000 FIXED HALF-PULLEY	-	-	-	-
	VARIABLE-SPEED DRIVE ADJUSTER SPRING FOR VARIATOR	PG. 445	*71*	PG.445	PG.445
	TORSION CONTROLLER ANTIFRICTION FIFTH WHEEL	-	-	2513210 € 5,72	2513210 € 5,72
	TORQUE DRIVER MOBILE DRIVEN SPLIT PULLEY	-	-	6111656 € 123,88	-
	OVER RANGE TRANSMISSION KIT	-	-	-	-
	MAXI FLY CLUTCH NOT ADJUSTABLE CLUTCH	-	-	-	-
	MAXI DELTA CLUTCH ADJUSTABLE CLUTCH	-	5216462 € 120,42	5211821 € 120,42	5216462 € 120,42
	MAXI CLUTCH BELL CLUTCH BELL (SMOOTH RING)	7715648 € 38,00 Ø 125	7715647 € 43,00 Ø 134	-	7715647 *10* € 43,00 Ø 134
	MAXI WING CLUTCH BELL CLUTCH BELL (FINNED RING)	-	-	7715898B € 52,00 Ø 134	-
	MAXI FLY SYSTEM CLUTCH BELL + NOT ADJUSTABLE CLUTCH	-	-	-	-
	MAXI DELTA SYSTEM CLUTCH BELL + ADJUSTABLE CLUTCH	-	5216569 € 135,00 Ø 134	5216918 € 136,00 Ø 134	5216569 € 135,00 Ø 134
	SPRINGS FOR MAXI FLY CLUTCH	-	-	-	-
	SPRINGS FOR MAXI DELTA CLUTCH	-	-	2911326 € 17,00	-
	SPRINGS FOR ORIGINAL CLUTCH	2912536 € 15,56	2911326 € 17,00	2911326 € 17,00	2911326 € 17,00

Products to be used exclusively for racing in places specially designed for such activity according to the regulations of the competent sporting authorities. We accept no liability resulting from improper use.

10 - ATTENTION * ONLY FOR vehicles CIRCULATING in: INDONESIA - SINGAPORE - THAILAND - VIETNAM: 7715648 € 38,00***71*** - For vehicles WITH pulley with LATERAL HOOKS "N°": "1" - 29 8360.WO € 6,50 / "2" - 29 7046.R0 € 5,91***PG*** - SPECIFICATIONS on the PAGE indicated in the TITLE of the LINE**TEC2** ** ATTENTION ** PLEASE CHECK THE PROPER FITMENT : PAGE 414

VESPA			WT MOTORS		YAMAHA		
S euro 3	Sprint 3V ie euro 3 2014->	Sprint 3V ie euro 3 2014->	ATENE	MIAMI	BW'S ie euro 3	CYGNUS	CYGNUS X
(LEADER)			(1P58MJA)	(172MM)	(E3G3E)		
150 4T	125 4T	150 4T	152 4T	250 4T	125 4T	125 4T	125 4T
3111393 €302,60 Ø 70	-	-	-	-	-	-	3113025 €303,85 Ø 58
-	3116550 €530,45 Ø 63	3116550 €530,45 Ø 63	-	-	3113792 €510,00 Ø 58	-	-
-	-	-	-	-	-	-	-
-	-	-	-	-	-	-	-
-	-	-	-	-	-	-	-
-	-	-	-	-	-	-	-
-	-	-	-	-	-	-	-
-	-	-	-	-	-	-	-
-	-	-	-	-	-	-	-
-	5515735 €88,00	5515735 €88,00	-	-	-	-	-
5111397 €112,35	5116149 €112,35	5116149 €112,35	5114272 €112,35	5113822 €119,13	5112701 €112,35	5111567 €112,35	5112701 €112,35
6116117 €34,27	6116148 €31,00	6116148 €31,00	6114127 €24,42 6116422 €48,57	6116118 €35,00	6116666 €41,00	-	6116419 €44,00
6611095.R0 €13,64 gr.14	6611095.H0 €13,64 gr.10	6611095.H0 €13,64 gr.10	6611095.M0 €13,64 gr.11,5	66 9917.C0 €19,12 gr.14	6611095.D0 €13,64 gr.08	6611095.E0 €13,64 gr.08,5	6611095.D0 €13,64 gr.08
-	-	-	-	66 9915.D0 €17,80 gr.23	6611156.H0 €20,11 gr.12	-	6611156.H0 €20,11 gr.12
-	-	-	-	-	6111703 €36,72	-	6111703 €36,72
PG.445	*71*	*71*	PG.445	-	2912647.Y0 *PG* €10,00	2912647.Y0 *PG* €10,00	2912647.Y0 *PG* €10,00
2513210 €5,72	-	-	-	-	-	-	-
6111656 €123,88	-	-	-	-	6112879 €123,88	-	6112879 €123,88
-	-	-	-	-	-	-	-
-	-	-	5212522 €70,37	-	5212544 €70,37	-	5212544 €70,37
5211821 €120,42	-	-	5212487 €112,59	5211467 €129,23	5212450 €112,59	-	5212450 €112,59
-	7715648 €38,00 Ø 125	7715648 €38,00 Ø 125	7714325 €33,00 Ø 125	-	7714335 €41,00 Ø 120	-	7714335 €41,00 Ø 120
7715898B €52,00 Ø 134	-	-	-	7715916B €52,00 Ø 135	-	-	-
-	-	-	5214724 €100,47 Ø 125	-	5214727 €109,14 Ø 120	-	5214727 €109,14 Ø 120
5216918 €136,00 Ø 134	-	-	-	5216184 €136,00 Ø 135	-	-	-
-	-	-	29 9605 €16,20	-	29 9605 €16,20	-	29 9605 €16,20
2911326 €17,00	-	-	29 9605 €16,20	2911326 €17,00	29 9605 €16,20	-	29 9605 €16,20
2911326 €17,00	2912536 €15,56	2912536 €15,56	-	2911326 €17,00	29 9605 €16,20	-	2911326 €17,00



MALOSSI

Maxi Scooter

125 → 800 4T

with ENGINE **VESPA**Primavera 3V
ie euro 3
2014->Primavera 3V
ie euro 3
2014->S
euro 3S 3V
ie euro 3
2012->

(M811M)

(M812M)

(LEADER M444M)

() CHECK "TYPE" SPECIFICATION (HOMOLOGATION MARK).

125 4T













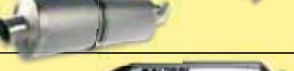



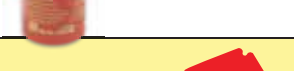















150 4T







125 4T



125 4T



	CLUTCH DISK SET FOR ORIGINAL CLUTCH		-	-	-	-
	MAXI WILD LION () HOMOLOGATED EXHAUST SYSTEM		-	-	-	-
	RX () HOMOLOGATED EXHAUST SYSTEM		3216551 € 502,00 BLACK	3216551 € 502,00 BLACK	-	-
	RED CHILLI OIL OIL FILTER		0313382 € 7,00	0313382 € 7,00	0313382 € 7,00	0313382 € 7,00
	RED SPONGE FOR ORIGINAL AIR BOX		1416576 € 4,20	1416576 € 4,20	-	1416576 € 4,20
	DOUBLE RED SPONGE FOR ORIGINAL AIR BOX		-	-	1414532 € 6,70	-
	W BOX FOR ORIGINAL AIR BOX		-	-	-	-
	V FILTER VARIATOR AIR FILTER RIGHT SIDE		-	-	-	-
	POWER TRASMISSION		-	-	-	-
	GEARS HTQ PRIMARY		-	-	-	-
	GEARS HTQ SECONDARY		-	-	6711860 € 60,41 z 16/42	-
	SPORT SCREEN SCREEN		4516332 € 75,00	4516332 € 75,00	-	-
	MHR SCREEN SCREEN		-	-	-	-
	HOSE KIT FOR BRAKE		-	-	-	-
	BRAKE PADS FRONT ORGANIC BRAKE PADS		6215062 € 8,32	6215062 € 8,32	6215049 € 6,24	6215049 € 6,24
	BRAKE PADS MHR FRONT ORGANIC BRAKE PADS		6215079 € 8,20	6215079 € 8,20	6215074 € 6,30	6215074 € 6,30
	BRAKE PADS MHR SYNT FRONT SINTERED BRAKE PADS		6215013 € 16,50	6215013 € 16,50	6215006 € 11,96	6215006 € 11,96
	BRAKE PADS REAR ORGANIC BRAKE PADS		-	-	-	-
	BRAKE PADS MHR REAR ORGANIC BRAKE PADS		-	-	-	-
	BRAKE PADS MHR SYNT REAR SINTERED BRAKE PADS		-	-	-	-
	BRAKE POWER REAR BRAKE SHOES		-	-	-	-
	DISC / WHOOP DISC / PAIR WHOOP FRONT BRAKE DISC		6212604 € 76,38	6212604 € 76,38	6212604 € 76,38	6212604 € 76,38
	DISC / WHOOP DISC REAR BRAKE DISC		-	-	-	-
	TWINS MAXI SUSPENSIONS REAR PAIR SHOCK ABSORBER		-	-	-	-
	RS3 - RS1 REAR SHOCK ABSORBER		-	-	-	-
	RS24 REAR SHOCK ABSORBER		-	-	-	-
	RS24 FRONT SHOCK ABSORBER		-	-	46 7900 € 222,63	46 7900 € 222,63
	RS24 FRONT + REAR		-	-	-	-
	F32S FORK STEMS Ø 32		-	-	-	-
	F37R FORK STEMS Ø 37		-	-	-	-

VESPA			WT MOTORS		YAMAHA		
S euro 3	Sprint 3V ie euro 3 2014->	Sprint 3V ie euro 3 2014->	ATENE	MIAMI	BW'S ie euro 3	CYGNUS	CYGNUS X
(LEADER)			(1P58MJA)	(172MM)	(E3G3E)		
150 4T 	125 4T 	150 4T 	152 4T LC	250 4T LC	115 4T 	125 4T 	125 4T 
-	-	-	-	-	-	-	-
-	-	-	-	-	-	-	-
-	3216551 € 502,00 BLACK	3216551 € 502,00 BLACK	-	-	-	-	-
0313382 € 7,00	0313382 € 7,00	0313382 € 7,00	-	-	-	-	-
-	1416576 € 4,20	1416576 € 4,20	-	-	-	-	-
1414532 € 6,70	-	-	-	-	-	-	-
-	-	-	-	-	-	-	-
-	-	-	-	-	-	-	-
-	-	-	-	-	-	-	-
6711860 € 60,41 z 16/42	-	-	-	-	-	-	-
-	4516342 € 75,00	4516342 € 75,00	-	-	-	-	-
-	-	-	-	-	-	-	-
6215049 € 6,24	-	-	-	6215055 € 8,84	-	-	-
6215074 € 6,30	-	-	-	6215078 € 8,84	-	-	-
6215006 € 11,96	-	-	-	-	-	-	-
-	-	-	-	6215055 € 8,84	-	-	-
-	-	-	-	6215078 € 8,84	-	-	-
-	-	-	-	-	-	-	-
-	-	-	-	-	-	-	-
6212604 € 76,38	-	-	-	-	-	-	-
-	-	-	-	-	-	-	-
-	-	-	-	-	-	-	-
-	-	-	-	-	-	-	-
46 7900 € 222,63	-	-	-	-	-	-	-
-	-	-	-	-	-	-	-
-	-	-	-	-	-	-	-
-	-	-	-	-	-	-	-



MALOSS

Maxi Scooter

125 → 800 4T

with ENGINE 

YAMAHA

CYGNUS X
ie euro 3D'ELIGHT
euro 3

MAJESTY

MAJESTY S
ie

(E3M5E)

125 4T



115 4T



125 4T

LC

125 4T

LC

Products to be used exclusively for racing in places specially designed for such activity according to the regulations of the competent sporting authorities. We accept no liability resulting from improper use.

	CYLINDER 4 STROKE ALUMINIUM	-	-	3111248 € 295,09 Ø 63	-
	CYLINDER I-TECH ALUMINIUM EQUIPPED WITH CDI	3113792 € 510,00 Ø 58	-	-	-
	POWER CAM CAMSHAFT	-	-	5911854 € 162,39	-
	HEAD V4 HEAD FOR ORIGINAL CYLINDER / MALOSS	-	-	-	-
	CYLINDER + V4 HEAD ALUMINIUM	-	-	-	-
	CYLINDER + V4 HEAD + POWER CAM ALUMINIUM Ø 75,5	-	-	-	-
	4 STROKE VALVE FOR ENGINE VALVES SET	-	-	-	-
	SPRINGS FOR ENGINE VALVES	-	-	-	-
	CRANKSHAFT RHQ	-	-	-	-
	IGNITION CONTROLLER DIGITRONIC FOR VEHICLES WITHOUT IMMOBILIZER	-	-	-	-
	IGNITION CONTROLLER DIGITRONIC FOR VEHICLES WITH IMMOBILIZER	-	-	-	-
	FORCE MASTER INJECTION CONTROLLER	-	-	-	-
	TC UNIT O2 controller LAMBDA EMULATOR	-	-	-	-
	MULTIVAR 2000 VARIATOR MULTIVAR 2000 MHR	5112701 € 112,35	5116287 € 78,00	5113134 € 112,35	5115222 € 122,57
	X SPECIAL BELT BELT X K BELT BELT	6116419 € 44,00	-	6116101 € 42,50	6115278 € 38,76
	HTRoll ROLLERS FOR MULTIVAR 2000 / MHR	6611095.DO € 13,64 gr.08	66 9420.KO € 10,00 gr.12	6611095.DO+.IO € 13,64 gr.08 (3) +10,5 (3)	6611095.IO € 13,64
	HTRoll ROLLERS FOR ORIGINAL VARIATOR	6611156.CO € 20,11 gr.09	66 9417.NO € 7,24 gr.08,3	6611156.CO € 20,11 gr.09	-
	VENTILVAR 2000 FIXED HALF-PULLEY	6111703 € 36,72	-	6111703 € 36,72	-
	VARIABLE-SPEED DRIVE ADJUSTER SPRING FOR VARIATOR	PG. 445 2912647.YO *PG* € 10,00	29 7046.R0 *PG* € 5,91	2912647.YO *PG* € 10,00	2915464.W0 *PG* € 15,45
	TORSION CONTROLLER ANTIFRICTION FIFTH WHEEL	-	-	-	-
	TORQUE DRIVER MOBILE DRIVEN SPLIT PULLEY	6112879 € 123,88	-	6111660 € 123,88	-
	OVER RANGE TRANSMISSION KIT	-	-	-	-
	MAXI FLY CLUTCH NOT ADJUSTABLE CLUTCH	5212544 € 70,37	-	5212544 € 70,37	-
	MAXI DELTA CLUTCH ADJUSTABLE CLUTCH	5212450 € 112,59	-	5212450 € 112,59	-
	MAXI CLUTCH BELL CLUTCH BELL (SMOOTH RING)	7714335 € 41,00 Ø 120	-	7714335 € 41,00 Ø 120	-
	MAXI WING CLUTCH BELL CLUTCH BELL (FINNED RING)	-	-	-	-
	MAXI FLY SYSTEM CLUTCH BELL + NOT ADJUSTABLE CLUTCH	5214727 € 109,14 Ø 120	-	5214727 € 109,14 Ø 120	-
	MAXI DELTA SYSTEM CLUTCH BELL + ADJUSTABLE CLUTCH	-	-	-	-
	SPRINGS FOR MAXI FLY CLUTCH	29 9605 € 16,20	-	29 9605 € 16,20	-
	SPRINGS FOR MAXI DELTA CLUTCH	29 9605 € 16,20	-	29 9605 € 16,20	-
	SPRINGS FOR ORIGINAL CLUTCH	2911326 € 17,00	2911325 € 17,24	2911325 € 17,24	-

PG - SPECIFICATIONS on the PAGE indicated in the TITLE of the LINE

YAMAHA

187

MAJESTY		MAJESTY		MAJESTY		MAJESTY <-2008		MAJESTY euro 3 2009->		MAXSTER		MAXSTER		SMaxie	
							(H317E)		(H322E)						
150 4T	LC	180 4T	LC	250 4T	LC	400 4T	LC	400 4T	LC	125 4T	LC	150 4T	LC	125 4T	LC
3111248		-		31 9578		-		-		3111248		3111248		-	
€ 295,09	Ø 63			€ 363,37	Ø 74					€ 295,09	Ø 63	€ 295,09	Ø 63		
-		-		-		-		-		-		-		3114945	
														€ 530,45	Ø 63
5911854		5911854		5911517		-		-		5911854		5911854		-	
€ 162,39		€ 162,39		€ 196,11						€ 162,39		€ 162,39			
-		-		-		-		-		-		-		-	
-		-		-		-		-		-		-		-	
-		-		-		-		-		-		-		-	
-		-		2711824		-		-		-		-		-	
				€ 77,38											
-		-		-		-		-		-		-		-	
-		-		-		-		-		-		-		-	
-		-		-		-		-		-		-		-	
-		-		-		-		-		-		-		-	
-		-		-		-		-		-		-		-	
5113134		5113134		5111225		5113595		5114148		5113134		5113134		5115222	
€ 112,35		€ 112,35		€ 121,97		€ 164,80		€ 177,00		€ 112,35		€ 112,35		€ 122,57	
6116101		6116101		6116094		6112960		6115280		6116101		6116101		6115278	
€ 42,50		€ 42,50		€ 40,00		€ 91,62		€ 77,15		€ 42,50		€ 42,50		€ 38,76	
6611095.D0+.IO		6611095.IO		66 9919.G0		6613561.AO		6613561.AO		6611095.D0+.IO		6611095.D0+.IO		6611095.IO	
€ 13,64 gr.08 (3) +10,5 (3)		€ 13,64		€ 22,15 gr.11		€ 26,00 gr.12		€ 26,00 gr.12		€ 13,64 gr.08 (3) +10,5 (3)		€ 13,64 gr.08 (3) +10,5 (3)		€ 13,64	
6611156.E0		-		66 9919.L0		6613561.DO		6613561.G0		6611156.C0		6611156.E0		-	
€ 20,11 gr.10				€ 22,15 gr.14		€ 26,00 gr.15		€ 26,00 gr.18		€ 20,11 gr.09		€ 20,11 gr.10			
6111703		6111703		6111102B		-		-		6111703		6111703		-	
€ 36,72		€ 36,72		€ 36,72						€ 36,72		€ 36,72			
2912647.Y0 *PG*		2912647.Y0 *PG*		PG.445		2914120.W0 *PG*		2914120.W0 *PG*		2912647.Y0 *PG*		2912647.Y0 *PG*		2915464.W0 *PG*	
€ 10,00		€ 10,00				€ 14,22		€ 14,22		€ 10,00		€ 10,00		€ 15,45	
-		-		-		-		-		-		-		-	
6111660		6111660		6111763		-		-		6111660		6111660		-	
€ 123,88		€ 123,88		€ 159,12						€ 123,88		€ 123,88			
-		-		-		-		-		-		-		-	
-		-		-		5212819		5212819		5212544		-		-	
						€ 146,14		€ 146,14		€ 70,37					
5211888		5211888		5211835 2000-> € 128,41		-		-		5212450		5211888		-	
€ 120,42		€ 120,42		5211468 <-1999 € 129,23						€ 112,59		€ 120,42			
7713368		7713368		7713369 Ø 145 2000-> € 56,50		-		-		7714335		7713368		-	
€ 59,00 Ø 135		€ 59,00 Ø 135		7713368 Ø 135 <-1999 € 59,00						€ 41,00 Ø 120		€ 59,00 Ø 135			
-		-		-		7715582B		7715582B		-		-		-	
						€ 55,00 Ø 160		€ 55,00 Ø 160							
-		-		-		5216331		5216331		5214727		-		-	
						€ 165,00 Ø 160		€ 165,00 Ø 160		€ 109,14 Ø 120					
-		-		5214721		-		-		-		-		-	
				€ 137,70 Ø 145 2000->											
-		-		-		2913137		2913137		29 9605		-		-	
						€ 20,99		€ 20,99		€ 16,20					
2911326		2911326		2911848 2000-> € 17,00		-		-		29 9605		2911326		-	
€ 17,00		€ 17,00		2911326 <-1999 € 15,94						€ 16,20		€ 17,00			
2911326		2911848		2911848 2000-> € 17,00		2911848		2914151		2911325		2911326		-	
€ 17,00		€ 17,00		2911326 <-1999 € 15,94		€ 17,00		€ 21,00		€ 17,24		€ 17,00			

MAXI SCOOTER 125 → 800 4T



MALOSSI

Maxi Scooter

125 → 800 4T

with ENGINE 

YAMAHA

CYGNUS X
ie euro 3D'ELIGHT
euro 3

MAJESTY

MAJESTY S
ie

(E3M5E)

125 4T



115 4T













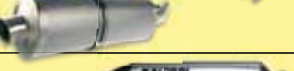



















125 4T

LC

125 4T

LC

CHECK "TYPE" SPECIFICATION (HOMOLOGATION MARK).

	CLUTCH DISK SET FOR ORIGINAL CLUTCH		-	-	-	-
	MAXI WILD LION  HOMOLOGATED EXHAUST SYSTEM	PG. 418	-	-	-	-
	RX  HOMOLOGATED EXHAUST SYSTEM	PG. 420	-	-	-	-
	RED CHILLI OIL OIL FILTER		-	-	-	-
	RED SPONGE FOR ORIGINAL AIR BOX		-	-	-	-
	DOUBLE RED SPONGE FOR ORIGINAL AIR BOX		-	-	-	-
	W BOX FOR ORIGINAL AIR BOX		-	-	-	-
	V FILTER VARIATOR AIR FILTER RIGHT SIDE		-	-	-	-
	POWER TRASMISSION		-	-	-	-
	GEARS HTQ PRIMARY		-	-	-	-
	GEARS HTQ SECONDARY		-	-	6711238 € 68,58 z 14/43 <-2000	-
	SPORT SCREEN SCREEN		-	-	-	4516502
	MHR SCREEN SCREEN		-	-	-	€ 79,00
	HOSE KIT FOR BRAKE		-	-	-	-
	BRAKE PADS FRONT ORGANIC BRAKE PADS		-	-	6215052 € 8,00 1998->	-
	BRAKE PADS MHR FRONT ORGANIC BRAKE PADS		-	-	6211525 € 8,20 1998->	-
	BRAKE PADS MHR SYNT FRONT SINTERED BRAKE PADS		-	-	6215020 € 16,00 1998->	-
	BRAKE PADS REAR ORGANIC BRAKE PADS		-	-	-	-
	BRAKE PADS MHR REAR ORGANIC BRAKE PADS		-	-	-	-
	BRAKE PADS MHR SYNT REAR SINTERED BRAKE PADS		-	-	-	-
	BRAKE POWER REAR BRAKE SHOES		-	-	-	-
	DISC / WHOOP DISC / PAIR WHOOP FRONT BRAKE DISC	6214224 € 108,00	-	-	-	-
	DISC / WHOOP DISC REAR BRAKE DISC		-	-	-	-
	TWINS MAXI SUSPENSIONS REAR PAIR SHOCK ABSORBER		-	-	4613171 € 253,00	-
	RS3 - RS1 REAR SHOCK ABSORBER		-	-	-	-
	RS24 REAR SHOCK ABSORBER		-	-	-	-
	RS24 FRONT SHOCK ABSORBER		-	-	-	-
	RS24 FRONT + REAR		-	-	-	-
	F32S FORK STEMS Ø 32		-	-	-	-
	F37R FORK STEMS Ø 37		-	-	-	-

12 - for VEHICLE with Front DOUBLE DISC, IF for VEHICLE with Front 1 DISC: HOMOLOGATED, MHR SYNT 6215033 € 21,50 - SPORT 6216901 € 10,61

YAMAHA

MAJESTY		MAJESTY		MAJESTY		MAJESTY <-2008		MAJESTY euro 3 2009->		MAXSTER		MAXSTER		SMax ie	
							(H317E)		(H322E)						
150 4T	LC	180 4T	LC	250 4T	LC	400 4T	LC	400 4T	LC	125 4T	LC	150 4T	LC	125 4T	LC
-		-		-		-		-		-		-		-	
-		-		-		-		-		-		-		-	
-		-		-		-		-		-		-		-	
-		-		-		0313380		0313380		-		-		-	
-		-		1411417		€3,80		€3,80		-		-		-	
-		-		€9,06						-		-		-	
-		-		1414502						-		-		-	
-		-		€7,35						-		-		-	
-		-		-		-		-		-		-		-	
-		-		-		-		-		-		-		-	
-		-		-		-		-		-		-		-	
-		-		-		-		-		-		-		-	
-		-		67 9974		-		-		6711238		-		-	
-		-		€90,27 z 17/37		-		-		€68,58 z 14/43 <-2000		-		-	
-		-		-		-		-		-		-		-	
-		-		-		-		-		-		-		-	
6215052		6215052		6216894		6216894		6216894		6215052		6215052		-	
€8,00 2001->		€8,00		€9,87 1996->		*12*		€9,87		€8,00 2001->		€8,00 2001->		-	
6211525		6211525		-		-		-		6211525		6211525		-	
€8,20 2001->		€8,20		-		-		-		€8,20 2001->		€8,20 2001->		-	
6215020		6215020		6215029		6215029		6215029		6215020		6215020		-	
€16,00 2001->		€16,00		€17,16 1996->		*12*		€17,16		€16,00 2001->		€16,00 2001->		-	
6216896		6216896		6216898		6216893		6216893		6216896		6216896		-	
€9,50 2001->		€9,50		€10,24 1998->		€10,61		€10,61		€9,50 2001->		€9,50 2001->		-	
-		-		-		-		-		-		-		-	
6215017		6215017		6215021		6215026		6215026		6215017		6215017		-	
€15,00 2001->		€15,00		€17,16 1998->		€18,72		€18,72		€15,00 2001->		€15,00 2001->		-	
-		-		-		-		-		-		-		-	
-		-		6212345		-		-		-		-		-	
-		-		€92,00 1996->		-		-		-		-		-	
-		-		-		-		-		-		-		-	
4613171		4613171		4613171		4613177		4613177		-		-		-	
€253,00		€253,00		€253,00		€230,00		€230,00		-		-		-	
-		-		-		-		-		-		-		-	
-		-		-		-		-		-		-		-	
-		-		-		-		-		-		-		-	
-		-		-		-		-		-		-		-	
-		-		-		-		-		-		-		-	
-		-		-		-		-		-		-		-	
-		-		-		-		-		-		-		-	



MALOSSI

Maxi Scooter

125 → 800 4T

with ENGINE 

YAMAHA

SMax
ieT MAX (carb.)
2001->2003T MAX
ie
2004->2007T MAX
ie
2008->2011

160 4T

LC

500 4T

LC

500 4T

LC

500 4T

LC

	CYLINDER 4 STROKE ALUMINIUM	-	-	3113687 *13* € 690,00 Ø 70	3113666 € 690,00 Ø 70
	CYLINDER I-TECH ALUMINIUM EQUIPPED WITH CDI	3115707 € 530,45 Ø 63	-	-	-
	POWER CAM CAMSHAFT	-	5913783 € 790,00	*14*	*14*
	HEAD V4 HEAD FOR ORIGINAL CYLINDER / MALOSSI	-	-	-	-
	CYLINDER + V4 HEAD ALUMINIUM	-	-	-	-
	CYLINDER + V4 HEAD + POWER CAM ALUMINIUM Ø 75,5	-	-	-	-
	4 STROKE VALVE FOR ENGINE VALVES SET	-	2715092 € 164,80	2715092 € 164,80	2715092 € 164,80
	SPRINGS FOR ENGINE VALVES	-	-	-	-
	CRANKSHAFT RHQ	-	-	-	-
	IGNITION CONTROLLER DIGITRONIC FOR VEHICLES WITHOUT IMMOBILIZER	-	-	-	-
	IGNITION CONTROLLER DIGITRONIC FOR VEHICLES WITH IMMOBILIZER	-	-	-	-
	FORCE MASTER INJECTION CONTROLLER	-	-	5514854 € 255,84	5514756 € 255,84
	TC UNIT 02 controller LAMBDA EMULATOR	-	-	5514747 € 84,00	5514747 € 84,00
	MULTIVAR 2000 VARIATOR MULTIVAR 2000 MHR	5115222 € 122,57	5113513 € 177,16	5113516 € 177,16 5114855 € 177,16	5113516 € 177,16 5114855 € 177,16
	X SPECIAL BELT BELT X K BELT BELT	6115278 € 38,76	6114674 € 105,76	6114674 € 105,76	6114674 € 105,76
	HTRoll ROLLERS FOR MULTIVAR 2000 / MHR	6611095.I0 € 13,64	6613561.E0+.G0 € 26,00 gr.16 +18	6613561.C0+.E0 € 26,00 gr.14 +16	6613561.C0+.E0 € 26,00 gr.14 +16
	HTRoll ROLLERS FOR ORIGINAL VARIATOR	-	6613561.L0 € 26,00 gr.20	6613561.G0 € 26,00 gr.18	6613561.G0 € 26,00 gr.18
	VENTILVAR 2000 FIXED HALF-PULLEY	-	6113806B € 64,88	6113806B € 64,88	6113806B € 64,88
	VARIABLE-SPEED DRIVE ADJUSTER SPRING FOR VARIATOR	PG. 445 2915464.W0*PG* € 15,45	PG.445	PG.445	PG.445
	TORSION CONTROLLER ANTIFRICTION FIFTH WHEEL	-	2514227 € 45,00	2514227 € 45,00	2514227 € 45,00
	TORQUE DRIVER MOBILE DRIVEN SPLIT PULLEY	-	6113495 € 202,98	6113495 € 202,98	6113495 € 202,98
	OVER RANGE TRANSMISSION KIT	-	-	6114885 € 549,78	6114885 € 549,78
	MAXI FLY CLUTCH NOT ADJUSTABLE CLUTCH	-	-	-	-
	MAXI DELTA CLUTCH ADJUSTABLE CLUTCH	-	-	-	-
	MAXI CLUTCH BELL CLUTCH BELL (SMOOTH RING)	-	-	-	-
	MAXI WING CLUTCH BELL CLUTCH BELL (FINNED RING)	-	-	-	-
	MAXI FLY SYSTEM CLUTCH BELL + NOT ADJUSTABLE CLUTCH	-	-	-	-
	MAXI DELTA SYSTEM CLUTCH BELL + ADJUSTABLE CLUTCH	-	-	-	-
	SPRINGS FOR MAXI FLY CLUTCH	-	-	-	-
	SPRINGS FOR MAXI DELTA CLUTCH	-	-	-	-
	SPRINGS FOR ORIGINAL CLUTCH	-	2913327 € 18,39	2913327 € 18,39	2913327 € 18,39

13 - ONLY FOR vehicles WITH HYDRAULIC CHAIN ADJUSTER: 3113666 € 690,00

14 - ONLY for Malossi CYLINDERS Ø 70 OR Malossi PAIR of PISTONS Ø 66 (3413706) for Original cylinder: 5913783 € 790,00

64 - TO COUPLE ONLY with MALOSSİ CYLINDERS : 5913877 € 229,69

PG - SPECIFICATIONS on the PAGE indicated in the TITLE of the LINE

YAMAHA

T MAX ie 2012->2014	T MAX ie 2015->	TEO'S	TEO'S	TRICITY ie	VERSITY XC	X CITY ie euro 3	X CITY ie euro 3
(J409E)	(J409E)				(H314E)	(E3A5E)	(G358E)
530 4T LC	530 4T LC	125 4T LC	150 4T LC	125 4T LC	300 4T LC	125 4T LC	250 4T LC
3115423 € 690,00 Ø 70	3115423 € 690,00 Ø 70	3111248 € 295,09 Ø 63	3111248 € 295,09 Ø 63	-	31 9578 € 363,37 Ø 74	-	-
-	-	-	-	-	-	3114443 € 530,45 Ø 63	3114268 € 556,20 Ø 74
5915981 € 826,00	5915981 € 826,00	5911854 € 162,39	5911854 € 162,39	-	5911517 € 196,11	*64*	-
-	-	-	-	-	-	-	-
-	-	-	-	-	-	-	-
-	-	-	-	-	-	-	-
-	-	-	-	-	2711824 € 77,38	-	2711824 € 77,38
-	-	-	-	-	-	-	-
-	-	-	-	-	-	-	-
5515730 € 298,00	5515730 € 298,00	-	-	-	-	-	-
5515720 € 84,00	5515720 € 84,00	-	-	-	-	-	-
5115470 € 188,49	5115470 € 188,49	5113134 € 112,35	5113134 € 112,35	5116663 € 112,35	5111225 € 121,97	5113134 € 112,35	5111225 € 121,97
6116011 € 127,88	6116011 € 127,88	6116101 € 42,50	6116101 € 42,50	6116667 € 44,00	6112714 € 55,71	6113059 € 59,36	6112714 € 55,71
6613561.C0+.E0 € 26,00 gr.14 +16	6613561.C0+.E0 € 26,00 gr.14 +16	6611095.D0+.I0 € 13,64 gr.08 (3) +10,5 (3)	6611095.D0+.I0 € 13,64 gr.08 (3) +10,5 (3)	6611095.F0 € 13,64 gr.09	66 9919.G0 € 22,15 gr.11	6611095.D0 € 13,64 gr.08	66 9919.G0 € 22,15 gr.11
6613561.G0 € 26,00 gr.18	6613561.G0 € 26,00 gr.18	6611156.C0 € 20,11 gr.09	6611156.E0 € 20,11 gr.10	66 9919.E0 € 22,15 gr.10	66 9919.M0 € 22,15 gr.14,5	6611156.E0 € 20,11 gr.10	66 9919.H0 € 22,15 gr.12
6115285B € 64,88	6115285B € 64,88	6111703 € 36,72	6111703 € 36,72	-	6111102B € 36,72	6111703 € 36,72	6111102B € 36,72
PG.445	PG.445	2912647.Y0 *PG* € 10,00	2912647.Y0 *PG* € 10,00	-	29 9975.Y0 *PG* € 10,71	2912647.Y0 *PG* € 10,00	29 9975.Y0 *PG* € 10,71
2514227 € 45,00	2514227 € 45,00	-	-	-	-	-	-
6115289 € 209,10	6115289 € 209,10	6111660 € 123,88	6111660 € 123,88	-	6111763 € 159,12	6111660 € 123,88	6111763 € 159,12
6115472 € 493,68	6115472 € 493,68	-	-	-	-	-	-
-	-	5212544 € 70,37	-	-	-	-	-
-	-	5212450 € 112,59	5211888 € 120,42	-	5211835 € 128,41	5211888 € 120,42	5211835 € 128,41
-	-	7714335 € 41,00 Ø 120	7713368 € 59,00 Ø 135	-	7713369 € 56,50 Ø 145	7713368 € 59,00 Ø 135	7713369 € 56,50 Ø 145
-	-	-	-	-	-	-	-
-	-	5214727 € 109,14 Ø 120	-	-	-	-	-
-	-	-	-	-	5214721 € 137,70 Ø 145	-	5214721 € 137,70 Ø 145
-	-	29 9605 € 16,20	-	-	-	-	-
-	-	29 9605 € 16,20	2911326 € 17,00	-	2911848 € 17,00	2911326 € 17,00	2911848 € 17,00
2915602 € 18,39	2915602 € 18,39	2911325 € 17,24	2911326 € 17,00	2912536 € 15,56	2911848 € 17,00	2911848 € 17,00	2911848 € 17,00













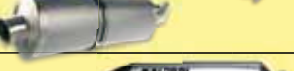

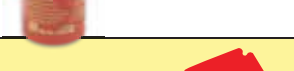















MALOSSİ

Maxi Scooter

125 → 800 4T

with ENGINE **YAMAHA**SMax
ieT MAX (carb.)
2001->2003T MAX
ie
2004->2007T MAX
ie
2008->2011**() CHECK "TYPE" SPECIFICATION (HOMOLOGATION MARK).**

160 4T LC 500 4T LC 500 4T LC 500 4T LC

	CLUTCH DISK SET FOR ORIGINAL CLUTCH		-	5215401 € 89,00	5215401 € 89,00	5215401 € 89,00
	MAXI WILD LION () HOMOLOGATED EXHAUST SYSTEM	PG. 418	-	3212721 € 499,01	3212721 € 499,01	3214130 € 683,40
	RX () HOMOLOGATED EXHAUST SYSTEM	PG. 420	-	-	-	-
	RED CHILLI OIL OIL FILTER		-	0313639 € 7,64	0313639 € 7,64	0313639 € 7,64
	RED SPONGE FOR ORIGINAL AIR BOX		-	-	-	-
	DOUBLE RED SPONGE FOR ORIGINAL AIR BOX		-	-	-	-
	W BOX FOR ORIGINAL AIR BOX		-	1413703 € 49,00	1413703 € 49,00	1414213 € 49,00
	V FILTER VARIATOR AIR FILTER RIGHT SIDE		-	0414614 € 41,36	0414614 € 41,36	0414614 € 41,36
	POWER TRASMISSION	PG. 489	-	PG.489	PG.489	PG.489
	GEARS HTQ PRIMARY		-	-	-	-
	GEARS HTQ SECONDARY		-	-	-	-
	SPORT SCREEN SCREEN		-	4515361 € 63,00	4515361 € 63,00	4514760 € 63,00
	MHR SCREEN SCREEN		-	-	2213103 € 175,00	2214135 € 180,00
	HOSE KIT FOR BRAKE		-	-	-	-
	BRAKE PADS FRONT ORGANIC BRAKE PADS		-	6216901 € 10,61	6216894 € 9,87	6216895 1996-> € 12,44
	BRAKE PADS MHR FRONT ORGANIC BRAKE PADS		-	-	-	-
	BRAKE PADS MHR SYNT FRONT SINTERED BRAKE PADS		-	6215033 € 21,50	6215029 € 17,16	6215022 € 17,68
	BRAKE PADS REAR ORGANIC BRAKE PADS		-	6216900 € 10,24	6216893 € 10,61	6216893 € 10,61
	BRAKE PADS MHR REAR ORGANIC BRAKE PADS		-	-	-	-
	BRAKE PADS MHR SYNT REAR SINTERED BRAKE PADS		-	6215030 € 18,75	6215026 € 18,72	6215026 € 18,72
	BRAKE POWER REAR BRAKE SHOES		-	-	-	-
	DISC / WHOOP DISC / PAIR WHOOP FRONT BRAKE DISC		-	6212347 € 94,00	6216320E € 237,50	6213715 € 274,00
	DISC / WHOOP DISC REAR BRAKE DISC		-	6213319 € 129,50	6213319 € 129,50	6213319 € 129,50
	TWINS MAXI SUSPENSIONS REAR PAIR SHOCK ABSORBER		-	-	-	-
	RS3 - RS1 REAR SHOCK ABSORBER		-	-	-	-
	RS24 REAR SHOCK ABSORBER		-	4613598 € 830,00	4613598 € 830,00	4613598 € 830,00
	RS24 FRONT SHOCK ABSORBER		-	-	-	-
	RS24 FRONT + REAR		-	-	-	-
	F32S FORK STEMS Ø 32		-	-	-	-
	F37R FORK STEMS Ø 37		-	-	-	-

YAMAHA

T MAX ie 2012->2014	T MAX ie 2015->	TEO'S	TEO'S	TRICITY ie	VERSITY XC	X CITY ie euro 3	X CITY ie euro 3
(J409E)	(J409E)				(H314E)	(E3A5E)	(G358E)
530 4T LC	530 4T LC	125 4T LC	150 4T LC	125 4T LC	300 4T LC	125 4T LC	250 4T LC
5215608 € 104,00	5215608 € 104,00	-	-	-	-	-	-
3216407 € 670,00	3216407 € 670,00	-	-	-	-	-	-
-	-	-	-	3216840 € 380,00	-	3214827 € 380,00	3214831 € 380,00
0313639 € 7,64	0313639 € 7,64	-	-	-	-	0313826 € 6,00	-
-	-	-	-	-	-	-	-
-	-	-	-	-	-	-	-
1414213 € 49,00	1414213 € 49,00	-	-	-	-	1415338 € 45,00	-
0415216 € 42,57	0415216 € 42,57	-	-	-	-	-	-
-	-	-	-	-	-	-	-
-	-	-	-	-	-	-	-
-	-	6711238 € 68,58 z 14/43 <-2000	-	-	-	6713301 € 97,48 z 14/43	-
4515359 € 65,00 4516328 € 67,00	4515359 € 65,00 4516328 € 67,00	-	-	-	-	-	-
2215529 € 191,00	2215529 € 191,00	-	-	-	-	-	-
6216895 € 12,44	6216895 € 12,44	-	-	-	6216890 € 9,87	6216890 € 9,87	6216890 € 9,87
-	-	-	-	-	-	-	-
6215022 € 17,68	6215022 € 17,68	-	-	-	6215027 2005-> € 16,64 6215020 <-2004 € 16,00	6215027 € 16,64	6215027 € 16,64
6216900 € 10,24	6216900 € 10,24	-	-	-	-	6216896 € 9,50	6216898 € 10,24
-	-	-	-	-	-	-	-
6215030 € 18,75	6215030 € 18,75	-	-	-	6215020 € 16,00	6215017 € 15,00	6215021 € 17,16
-	-	-	-	-	-	-	-
6216320E € 237,50	6216320E € 237,50	-	-	-	-	-	-
6215594 € 129,50	6215594 € 129,50	-	-	-	-	-	-
-	-	-	-	-	4613462 € 243,00	4613171 € 253,00	-
-	-	-	-	-	-	-	-
4613598 € 830,00	4613598 € 830,00	-	-	-	-	-	-
-	-	-	-	-	-	-	-
-	-	-	-	-	-	-	-
-	-	-	-	-	-	-	-
-	-	-	-	-	-	-	-



MALOSS

Maxi Scooter

125 → 800 4T

with ENGINE 

YAMAHA

X CITY
ie euro 3
2014->Xenter
ieXenter
ieZUMA
ie euro 3

(G3B7E)

(G397E)

250 4T

LC

125 4T

LC

150 4T

LC

125 4T



	CYLINDER 4 STROKE ALUMINIUM	-	-	-	-
	CYLINDER I-TECH ALUMINIUM EQUIPPED WITH CDI	3114268 € 556,20 Ø 74	3114945 € 530,45 Ø 63	3115707 € 530,45 Ø 63	3113792 € 510,00 Ø 58
	POWER CAM CAMSHAFT	-	-	-	-
	HEAD V4 HEAD FOR ORIGINAL CYLINDER / MALOSS	-	-	-	-
	CYLINDER + V4 HEAD ALUMINIUM	-	-	-	-
	CYLINDER + V4 HEAD + POWER CAM ALUMINIUM Ø 75,5	-	-	-	-
	4 STROKE VALVE FOR ENGINE VALVES SET	2711824 € 77,38	-	-	-
	SPRINGS FOR ENGINE VALVES	-	-	-	-
	CRANKSHAFT RHQ	-	-	-	-
	IGNITION CONTROLLER DIGITRONIC FOR VEHICLES WITHOUT IMMOBILIZER	-	-	-	-
	IGNITION CONTROLLER DIGITRONIC FOR VEHICLES WITH IMMOBILIZER	-	-	-	-
	FORCE MASTER INJECTION CONTROLLER	-	-	-	-
	TC UNIT O2 controller LAMBDA EMULATOR	5515786 € 84,00	5515785 € 84,00	5515785 € 84,00	-
	MULTIVAR 2000 VARIATOR MULTIVAR 2000 MHR	5111225 € 121,97	5115222 € 122,57	5115222 € 122,57	5112701 € 112,35
	X SPECIAL BELT BELT X K BELT BELT	6112714 € 55,71	6115278 € 38,76	6115278 € 38,76	6116666 € 41,00
	HTRoll ROLLERS FOR MULTIVAR 2000 / MHR	66 9919.G0 € 22,15 gr.11	6611095.I0 € 13,64	6611095.I0 € 13,64	6611095.D0 € 13,64 gr.08
	HTRoll ROLLERS FOR ORIGINAL VARIATOR	66 9919.H0 € 22,15 gr.12	-	-	6611156.H0 € 20,11 gr.12
	VENTILVAR 2000 FIXED HALF-PULLEY	6111102B € 36,72	-	-	6111703 € 36,72
	VARIABLE-SPEED DRIVE ADJUSTER SPRING FOR VARIATOR	PG. 445 29 9975.YO *PG* € 10,71	2915464.WO *PG* € 15,45	2915464.WO *PG* € 15,45	2912647.YO *PG* € 10,00
	TORSION CONTROLLER ANTIFRICTION FIFTH WHEEL	-	-	-	-
	TORQUE DRIVER MOBILE DRIVEN SPLIT PULLEY	6111763 € 159,12	-	-	6112879 € 123,88
	OVER RANGE TRANSMISSION KIT	-	-	-	-
	MAXI FLY CLUTCH NOT ADJUSTABLE CLUTCH	-	-	-	5212544 € 70,37
	MAXI DELTA CLUTCH ADJUSTABLE CLUTCH	5211835 € 128,41	-	-	5212450 € 112,59
	MAXI CLUTCH BELL CLUTCH BELL (SMOOTH RING)	7713369 € 56,50 Ø 145	-	-	7714335 € 41,00 Ø 120
	MAXI WING CLUTCH BELL CLUTCH BELL (FINNED RING)	-	-	-	-
	MAXI FLY SYSTEM CLUTCH BELL + NOT ADJUSTABLE CLUTCH	-	-	-	5214727 € 109,14 Ø 120
	MAXI DELTA SYSTEM CLUTCH BELL + ADJUSTABLE CLUTCH	5214721 € 137,70 Ø 145	-	-	-
	SPRINGS FOR MAXI FLY CLUTCH	-	-	-	29 9605 € 16,20
	SPRINGS FOR MAXI DELTA CLUTCH	2911848 € 17,00	-	-	29 9605 € 16,20
	SPRINGS FOR ORIGINAL CLUTCH	2911848 € 17,00	-	-	29 9605 € 16,20

64 - TO COUPLE ONLY with MALOSS CYLINDERS : 5913877 € 229,69

PG - SPECIFICATIONS on the PAGE indicated in the TITLE of the LINE

YAMAHA

X MAX ie euro 3 <-2008		X MAX ie euro 3 2009->2013		X MAX ie euro 3 2014->		X MAX		X MAX ie euro 3 2008->2009		X MAX ie euro 3 2010->2013		X MAX ie euro 3 2014->		X MAX ie euro 3	
									(G362E)	(G389E)	(G389E)	(G389E)	(G389E)	(G389E)	(H330E)
125 4T	LC	125 4T	LC	125 4T	LC	250 4T	LC	250 4T	LC	250 4T	LC	250 4T	LC	400 4T	LC
-	-	-	-	-	-	31 9578 € 363,37 Ø 74	-	-	-	-	-	-	-	-	-
3114443 € 530,45 Ø 63	3114443 € 530,45 Ø 63	3114443 € 530,45 Ø 63	-	-	-	-	3114268 € 556,20 Ø 74	3114268 € 556,20 Ø 74	3114268 € 556,20 Ø 74	3114268 € 556,20 Ø 74	3114268 € 556,20 Ø 74	-	-	-	-
64	*64*	*64*	-	-	-	-	-	-	-	-	-	-	-	-	-
-	-	-	-	-	-	-	-	-	-	-	-	-	-	-	-
-	-	-	-	-	-	-	-	-	-	-	-	-	-	-	-
-	-	-	-	-	-	-	-	-	-	-	-	-	-	-	-
-	-	-	-	-	-	2711824 € 77,38	2711824 € 77,38	2711824 € 77,38	2711824 € 77,38	2711824 € 77,38	2711824 € 77,38	-	-	-	-
-	-	-	-	-	-	-	-	-	-	-	-	-	-	-	-
-	-	-	-	-	-	-	-	-	-	-	-	-	-	-	-
-	-	-	-	-	-	-	-	-	-	-	-	-	-	-	-
5515786 € 84,00	5515786 € 84,00	-	-	-	-	-	5515786 € 84,00	5515786 € 84,00	5515786 € 84,00	5515786 € 84,00	5515786 € 84,00	-	-	-	-
5113134 € 112,35	5113134 € 112,35	5113134 € 112,35	5111225 € 121,97	5111225 € 121,97	5111225 € 121,97	5111225 € 121,97	5111225 € 121,97	5111225 € 121,97	5111225 € 121,97	5111225 € 121,97	5111225 € 121,97	5114148 € 177,00	-	-	-
6113059 € 59,36	6113059 € 59,36	6113059 € 59,36	6112714 € 55,71	6112714 € 55,71	6112714 € 55,71	6112714 € 55,71	6112714 € 55,71	6112714 € 55,71	6112714 € 55,71	6112714 € 55,71	6112714 € 55,71	6115280 € 77,15	-	-	-
6611095.D0 € 13,64 gr.08	6611095.D0 € 13,64 gr.08	6611095.D0 € 13,64 gr.08	66 9919.G0 € 22,15 gr.11	66 9919.G0 € 22,15 gr.11	66 9919.G0 € 22,15 gr.11	66 9919.G0 € 22,15 gr.11	66 9919.G0 € 22,15 gr.11	66 9919.G0 € 22,15 gr.11	66 9919.G0 € 22,15 gr.11	66 9919.G0 € 22,15 gr.11	66 9919.G0 € 22,15 gr.11	6613561.A0 € 26,00 gr.12	-	-	-
6611156.E0 € 20,11 gr.10	6611156.E0 € 20,11 gr.10	6611156.E0 € 20,11 gr.10	66 9919.H0 € 22,15 gr.12	66 9919.H0 € 22,15 gr.12	66 9919.H0 € 22,15 gr.12	66 9919.H0 € 22,15 gr.12	66 9919.H0 € 22,15 gr.12	66 9919.H0 € 22,15 gr.12	66 9919.H0 € 22,15 gr.12	66 9919.H0 € 22,15 gr.12	66 9919.H0 € 22,15 gr.12	6613561.E0 € 26,00 gr.16	-	-	-
6111703 € 36,72	6111703 € 36,72	6111703 € 36,72	6111102B € 36,72	6111102B € 36,72	6111102B € 36,72	6111102B € 36,72	6111102B € 36,72	6111102B € 36,72	6111102B € 36,72	6111102B € 36,72	6111102B € 36,72	-	-	-	-
2912647.Y0 *PG* € 10,00	2912647.Y0 *PG* € 10,00	2912647.Y0 *PG* € 10,00	29 9975.Y0 *PG* € 10,71	29 9975.Y0 *PG* € 10,71	29 9975.Y0 *PG* € 10,71	29 9975.Y0 *PG* € 10,71	29 9975.Y0 *PG* € 10,71	29 9975.Y0 *PG* € 10,71	29 9975.Y0 *PG* € 10,71	29 9975.Y0 *PG* € 10,71	29 9975.Y0 *PG* € 10,71	2914120.W0 *PG* € 14,22	-	-	-
-	-	-	-	-	-	-	-	-	-	-	-	-	-	-	-
6111660 € 123,88	6111660 € 123,88	6111660 € 123,88	6111763 € 159,12	6111763 € 159,12	6111763 € 159,12	6111763 € 159,12	6111763 € 159,12	6111763 € 159,12	6111763 € 159,12	6111763 € 159,12	6111763 € 159,12	-	-	-	-
-	-	-	-	-	-	-	-	-	-	-	-	-	-	-	-
-	-	-	-	-	-	-	-	-	-	-	-	-	-	5212819 € 146,14	-
5211888 € 120,42	5211888 € 120,42	5211888 € 120,42	5211835 € 128,41	5211835 € 128,41	5211835 € 128,41	5211835 € 128,41	5211835 € 128,41	5211835 € 128,41	5211835 € 128,41	5211835 € 128,41	5211835 € 128,41	-	-	-	-
7713368 € 59,00 Ø 135	7713368 € 59,00 Ø 135	7713368 € 59,00 Ø 135	7713369 € 56,50 Ø 145	7713369 € 56,50 Ø 145	7713369 € 56,50 Ø 145	7713369 € 56,50 Ø 145	7713369 € 56,50 Ø 145	7713369 € 56,50 Ø 145	7713369 € 56,50 Ø 145	7713369 € 56,50 Ø 145	7713369 € 56,50 Ø 145	-	-	-	-
-	-	-	-	-	-	-	-	-	-	-	-	-	-	7715582B € 55,00 Ø 160	-
-	-	-	-	-	-	-	-	-	-	-	-	-	-	5216331 € 165,00 Ø 160	-
-	-	-	5214721 € 137,70 Ø 145	5214721 € 137,70 Ø 145	5214721 € 137,70 Ø 145	5214721 € 137,70 Ø 145	5214721 € 137,70 Ø 145	5214721 € 137,70 Ø 145	5214721 € 137,70 Ø 145	5214721 € 137,70 Ø 145	5214721 € 137,70 Ø 145	-	-	-	-
-	-	-	-	-	-	-	-	-	-	-	-	-	-	2913137 € 20,99	-
2911326 € 17,00	2911326 € 17,00	2911326 € 17,00	2911848 € 17,00	2911848 € 17,00	2911848 € 17,00	2911848 € 17,00	2911848 € 17,00	2911848 € 17,00	2911848 € 17,00	2911848 € 17,00	2911848 € 17,00	-	-	-	-
2911848 € 17,00	2911848 € 17,00	2911848 € 17,00	2911848 € 17,00	2911848 € 17,00	2911848 € 17,00	2911848 € 17,00	2911848 € 17,00	2911848 € 17,00	2911848 € 17,00	2911848 € 17,00	2911848 € 17,00	2914151 € 21,00	-	-	-



MALOSSI

Maxi Scooter

125 → 800 4T

with ENGINE 

YAMAHA

X CITY
ie euro 3
2014->Xenter
ieXenter
ieZUMA
ie euro 3

(G3B7E)

(G397E)

CHECK "TYPE" SPECIFICATION (HOMOLOGATION MARK).

250 4T

LC

125 4T











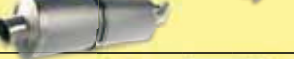







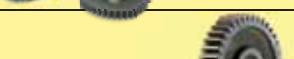



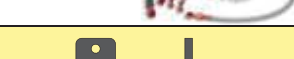

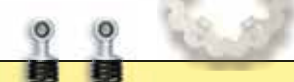

LC

150 4T

LC

125 4T



	CLUTCH DISK SET FOR ORIGINAL CLUTCH		-	-	-	-
	MAXI WILD LION  HOMOLOGATED EXHAUST SYSTEM	PG. 418	-	-	-	-
	RX  HOMOLOGATED EXHAUST SYSTEM	PG. 420	3214831 € 380,00	3216014 € 380,00	3216014 € 380,00	-
	RED CHILLI OIL OIL FILTER		-	-	-	-
	RED SPONGE FOR ORIGINAL AIR BOX		-	-	-	-
	DOUBLE RED SPONGE FOR ORIGINAL AIR BOX		-	-	-	-
	W BOX FOR ORIGINAL AIR BOX		1415338 € 45,00	-	-	-
	V FILTER VARIATOR AIR FILTER RIGHT SIDE		-	-	-	-
	POWER TRASMISSION		-	-	-	-
	GEARS HTQ PRIMARY		-	-	-	-
	GEARS HTQ SECONDARY		-	-	-	-
	SPORT SCREEN SCREEN		-	-	-	-
	MHR SCREEN SCREEN		-	-	-	-
	HOSE KIT FOR BRAKE		-	-	-	-
	BRAKE PADS FRONT ORGANIC BRAKE PADS		6216890 € 9,87	-	-	-
	BRAKE PADS MHR FRONT ORGANIC BRAKE PADS		-	-	-	-
	BRAKE PADS MHR SYNT FRONT SINTERED BRAKE PADS		6215027 € 16,64	-	-	-
	BRAKE PADS REAR ORGANIC BRAKE PADS		6216898 € 10,24	-	-	-
	BRAKE PADS MHR REAR ORGANIC BRAKE PADS		-	-	-	-
	BRAKE PADS MHR SYNT REAR SINTERED BRAKE PADS		6215021 € 17,16	-	-	-
	BRAKE POWER REAR BRAKE SHOES		-	-	-	-
	DISC / WHOOP DISC / PAIR WHOOP FRONT BRAKE DISC		-	-	-	-
	DISC / WHOOP DISC REAR BRAKE DISC		-	-	-	-
	TWINS MAXI SUSPENSIONS REAR PAIR SHOCK ABSORBER		-	-	-	-
	RS3 - RS1 REAR SHOCK ABSORBER		-	-	-	-
	RS24 REAR SHOCK ABSORBER		-	-	-	-
	RS24 FRONT SHOCK ABSORBER		-	-	-	-
	RS24 FRONT + REAR		-	-	-	-
	F32S FORK STEMS Ø 32		-	-	-	-
	F37R FORK STEMS Ø 37		-	-	-	-

YAMAHA

X MAX ie euro 3 <-2008		X MAX ie euro 3 2009->2013		X MAX ie euro 3 2014->		X MAX		X MAX ie euro 3 2008->2009		X MAX ie euro 3 2010->2013		X MAX ie euro 3 2014->		X MAX ie euro 3			
								(G362E)	(G389E)	(G389E)	(G389E)	(G389E)	(G389E)	(G389E)	(H330E)		
125 4T	LC	125 4T	LC	125 4T	LC	250 4T	LC	250 4T	LC	250 4T	LC	250 4T	LC	250 4T	LC	400 4T	LC
-		-		-		-		-		-		-		-		-	
-		-		-		-		-		-		-		-		3216400	
																€ 525,00	
3214827		3214827		-		-		3214831		3214831		3214831		-		-	
€ 380,00		€ 380,00						€ 380,00		€ 380,00		€ 380,00					
0313826		0313826		0313826		-		-		-		-		-		0313380	
€ 6,00		€ 6,00		€ 6,00											€ 3,80		
-		-		-		-		-		-		-		-		-	
-		-		-		-		-		-		-		-		-	
1415338		1415338		1415338		1415338		1415338		1415338		1415338		1415338		-	
€ 45,00		€ 45,00		€ 45,00		€ 45,00		€ 45,00		€ 45,00		€ 45,00		€ 45,00			
-		-		-		-		-		-		-		-		-	
-		-		-		-		-		-		-		-		-	
-		-		-		-		-		-		-		-		-	
6713301		6713301		6713301		-		-		-		-		-		-	
€ 97,48 z 14/43		€ 97,48 z 14/43		€ 97,48 z 14/43													
4514400		4514604		4516051B		4514400		4514400		4514604		4516051B		4516051B		4516051B	
€ 52,00		€ 52,00		€ 64,50		€ 52,00		€ 52,00		€ 52,00		€ 64,50		€ 64,50		€ 64,50	
-		-		-		-		-		-		-		-		-	
6216897		6216897 <-2009 € 8,77		6216890		6216897		6216897		6216890		6216890		6216890		6216890	
€ 8,77		6216890 2010->13 € 9,87		€ 9,87		€ 8,77		€ 8,77		€ 9,87		€ 9,87		€ 9,87		€ 9,87	
-		-		-		-		-		-		-		-		-	
6215023		6215023 <-2009 € 17,16		6215027		6215023		6215023		6215027		6215027		6215027		6215027	
€ 17,16		6215027 2010->13 € 16,64		€ 16,64		€ 17,16		€ 17,16		€ 16,64		€ 16,64		€ 16,64		€ 16,64	
6216896		6216896		-		-		6216898		6216898		6216898		6216898		6216899	
€ 9,50		€ 9,50						€ 10,24		€ 10,24		€ 10,24		€ 10,24		€ 9,50	
-		-		-		-		-		-		-		-		-	
6215017		6215017		-		-		6215021		6215021		6215021		6215021		6215028	
€ 15,00		€ 15,00						€ 17,16		€ 17,16		€ 17,16		€ 17,16		€ 20,00	
-		-		-		-		-		-		-		-		-	
-		-		-		-		-		-		-		6216320B		6216320E	
														€ 124,00		€ 237,50	
-		-		-		-		-		-		-		-		-	
4613171		4613171		-		4613171		4613171		4613171		-		-		-	
€ 253,00		€ 253,00				€ 253,00		€ 253,00		€ 253,00							
-		-		-		-		-		-		-		-		-	
-		-		-		-		-		-		-		-		-	
-		-		-		-		-		-		-		-		-	
-		-		-		-		-		-		-		-		-	
-		-		-		-		-		-		-		-		-	
-		-		-		-		-		-		-		-		-	
-		-		-		-		-		-		-		-		-	



MALOSSI

Scooter 2T

with ENGINE 

APRILIA

AREA 51

HABANA

MOJITO

MOJITO CUSTOM

50 2T

LC

50 2T



50 2T



50 2T

**(▲) ATTENTION: ONLY FOR vehicles WITHOUT IMMOBILIZER KEY**

	CYLINDER+HEAD CAST-IRON Ø 40	31 8556	1	31 9092	31 9092	31 8520	
	(pin) ALUMINIUM Ø 40-41	€161,98	Ø 40 (10)	€214,45	Ø 41 (10)	€124,91	Ø 40 (12)
	CYLINDER+HEAD	31 8284	1	31 8723	31 8723	31 6926	
	(pin) CAST-IRON Ø 47	€152,41	Ø 47 (10)	€123,02	Ø 47 (10)	€120,25	Ø 47 (12)
	CYLINDER CAST-IRON Ø 47-57,5	-	-	31 7137	31 7137	31 6915	
for ORIGINAL HEAD ALUM. Ø 47>57,5	-	-	€106,52	Ø 47 (10)	€106,52	Ø 47 (12)	
HEAD HTSR	-	-	38 9041	38 9041	38 7118		
for Malossi CYLINDER	-	-	€37,47	Ø 47	€37,45	Ø 47	
CYLINDER+HEAD MHR Replica ALUMINIUM	31 8430	1	-	-	31 8463		
(pin) Ø 47	€228,06	Ø 47 (10)	-	-	€207,00	Ø 47 (12)	
	CRANKSHAFTS RHQ	53 7891	-	53 9592	53 9592	-	
	PIN Ø 10	€175,50	-	€264,23	€264,23	-	
	CRANKSHAFTS RHQ	53 8009	-	-	-	53 7600	
	PIN Ø 12	€175,50	-	-	-	€175,50	
	RADIAL ROLLER BEARING FOR CRANKSHAFT	PG. 473	PG.473	-	-	6614105E	
	ELECTRONIC CONTROLLER	55 8133	-	-	-	5513195 *35*	
	(▲)	€50,14	-	-	-	€92,82	
	ELECTRONIC CONTROLLER RPM CONTROL	55 8676	-	-	-	5513196 *35*	
	(▲)	€97,59	-	-	-	€140,51	
	MULTIVAR VARIATOR	51 7075	-	5111298	5111298	51 9019	
	X SPECIAL BELT	6112730	-	6111295	6111295	61 9831	
	BELT	€14,36	-	€17,71	€17,71	€19,49	
	X K BELT	6112729	-	6111294	6111294	6114118	
	BELT	€25,23	-	€28,38	€28,38	€38,25	
HTRoll	66 9823.M0	-	66 9823.N0	66 9823.N0	66 9420.M0		
ROLLERS FOR MULTIVAR	€9,50 gr.07	-	€9,50 gr.08	€9,50 gr.08	€10,00 gr.07,2		
HTRoll	66 9417.H0	-	66 9999.G0	66 9999.G0	66 9420.N0		
ROLLERS FOR ORIGINAL VARIATOR	€7,24 gr.06,5	-	€8,50 gr.07	€8,50 gr.07	€10,00 gr.07,5		
	VENTILVAR FIXED HALF-PULLEY	61 7152	-	-	-	-	
		€21,71	-	-	-	-	
	VARIABLE-SPEED DRIVE ADJUSTER SPRING FOR VARIATOR	PG. 438	PG.438	PG.438	PG.438	PG.438	
	TORSION CONTROLLER ANTIFRICTION FIFTH WHEEL	2512827	-	-	-	2512828	
		€4,45	-	-	-	€4,45	
	TORQUE DRIVER MOBILE DRIVEN SPLIT PULLEY	61 9223	-	-	-	61 9100	
		€85,57	-	-	-	€85,57	
	FLY CLUTCH NOT ADJUSTABLE CLUTCH	52 9450	-	52 8798	52 8798	52 8797	
		€47,30	-	€47,30	€47,30	€47,30	
	DELTA CLUTCH ADJUSTABLE CLUTCH	52 9451	-	52 7879	52 7879	52 7880	
		€77,89	-	€77,89	€77,89	€77,89	
	CLUTCH BELL CLUTCH BELL (SMOOTH RING)	7711124	-	-	-	7711115	
		€22,60	Ø 107	-	-	€22,60	Ø 107
	WING CLUTCH BELL CLUTCH BELL (FINNED RING)	7711166	-	-	-	7711207	
		€33,45	Ø 107	-	-	€33,45	Ø 107
	FLY SYSTEM CLUTCH BELL + NOT ADJUSTABLE CLUTCH	5214112	-	-	-	5214111	
		€63,00	Ø 107	-	-	€63,00	Ø 107
	DELTA SYSTEM CLUTCH BELL + ADJUSTABLE CLUTCH	5214113	-	-	-	5214110	
		€93,84	Ø 107	-	-	€93,84	Ø 107
	SPORT SPRINGS FOR FLY / DELTA CLUTCH	29 8746	-	29 8746	29 8746	29 8746	
		€14,50	-	€14,50	€14,50	€14,50	
	MHR SPRINGS FOR FLY / DELTA CLUTCH	29 8747	-	29 8747	29 8747	29 8747	
		€19,40	-	€19,40	€19,40	€19,40	
	SPRINGS Ø INTERNAL CLUTCH BELL 105-107 FOR ORIGINAL CLUTCH	29 7714 Ø 105 €13,80	-	29 7456	29 7456	29 7454	
	29 9605 Ø 107 €16,20	-	€16,20	€16,20	€16,20		
MUELLES Ø INTERNAL CLUTCH BELL 112 FOR ORIGINAL CLUTCH	29 7715	-	-	-	-		
	€16,20	Ø 112	-	-	-		

27 - For vehicles with YAMAHA FLYWHEEL

32 - For vehicles with YAMAHA FLYWHEEL - If it is a DUCATI : TC UNIT K15 +BOBINA / RPM CONTROL 55 8765 € 127,73

35 - IT CAN BE ASSEMBLED WITH NO MODIFICATION to the original system, EVEN ON vehicles PRODUCED 2001->

PG - SPECIFICATIONS on the PAGE indicated in the TITLE of the LINE



MALOSSI

Scooter 2T

with ENGINE 

APRILIA

AREA 51

HABANA

MOJITO

MOJITO CUSTOM

50 2T

LC

50 2T















50 2T

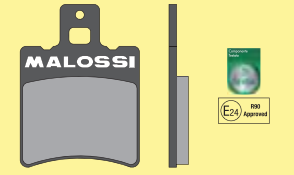

50 2T

**■ CHECK "TYPE" SPECIFICATION (HOMOLOGATION MARK)**

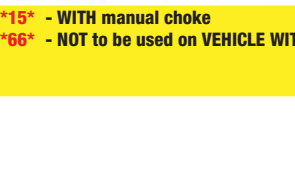
	CARBURETTOR		72 8121 € 81,54 Ø 17,5	-	-	72 7084 € 75,17 Ø 17,5
	CARBURETTOR KIT	Ø 19	1611042 € 118,04	1611292 € 133,26	1611292 € 133,26	1611040 € 118,04
	CARBURETTOR KIT	Ø 21	1610995 € 114,23	-	-	1610997 € 114,23
	CARBURETTOR KIT	Ø 22	1611026 *15* € 107,68	-	-	1611029 € 96,77
	REED VALVE CARBON FIBRE		27 7731.C0 € 48,95 VL12	27 7731.C0 € 48,95 VL12	27 7731.C0 € 48,95 VL12	27 7708.C0 € 48,95 VL11
	PETALS SET FOR ORIGINAL REED VALVE		27 7054.C0 € 18,71	27 7054.C0 € 18,71	27 7054.C0 € 18,71	27 7054.C0 € 18,71
	ART OF PERFORMANCE / FLIP HOMOLOGATED 	PG. 426	-	-	-	-
	WILD LION HOMOLOGATED 	PG. 424	-	-	-	-
	RED SPONGE FOR ORIGINAL AIR BOX		1411407 € 3,85	-	-	1411778 € 3,54
	DOUBLE RED SPONGE FOR ORIGINAL AIR BOX		1414507 € 5,30	-	-	1414497 € 6,16
	GEARS HTQ PRIMARY		6714039 € 57,67 z 13/44	6711297 € 121,34 z 15/40	6711297 € 121,34 z 15/40	-
	GEARS HTQ SECONDARY	PG. 478	6714774 z 15/42 € 67,32 6714775 z 14/43 € 67,32	-	-	-
	ROLLER CRANKCASE		2515482 € 95,00	-	-	2514521 *66* € 95,00
	SCREEN		-	-	-	-
	BRAKE PADS	FRONT	6215042 € 5,72 1998->	6215042 € 5,72 1998->	6215042 € 5,72 1998->	-
	BRAKE PADS MHR	FRONT	6215080 € 6,00 1998->	6215080 € 6,00 1998->	6215080 € 6,00 1998->	-
	BRAKE PADS MHR SYNT	FRONT	6215007 € 11,96 1998->	6215007 € 11,96 1998->	6215007 € 11,96 1998->	-
	BRAKE PADS	REAR	6215042 € 5,72 1998->	-	-	-
	BRAKE PADS MHR	REAR	6215080 € 6,00 1998->	-	-	-
	BRAKE PADS MHR SYNT	REAR	6215007 € 11,96 1998->	-	-	-
	BRAKE POWER	REAR	-	-	-	-
	BRAKE SHOES	FRONT	-	-	-	-
	WHOO P DISC	FRONT	-	-	-	-
	WHOO P DISC	REAR	-	-	-	-
	RS1 - RS3	REAR SHOCK ABSORBER	-	-	-	-
	RS24 - RS24/10	FRONT SHOCK ABSORBER	-	-	-	-
	RS24 - RS24/10 - RS24/10-R	REAR SHOCK ABSORBER	-	-	-	-
	RS24	FRONT + REAR	-	-	-	-
	HORQUILLA F32S	FORK STEMS Ø 32	-	-	-	-
	HORQUILLA F37R MHR	FORK STEMS Ø 37	-	-	-	-

15 - WITH manual choke

66 - NOT to be used on VEHICLE WITH ORIGINAL PRIMARY GEARS

APRILIA

RALLY		RALLY		SCARABEO		SCARABEO DITECH		SCARABEO STREET		SCARABEO		SONIC		SONIC	
(MINARELLI)		(MINARELLI)		(MINARELLI)				(PIAGGIO)							
50 2T	🔊	50 2T	LC	50 2T	🔊	50 2T	🔊	50 2T	🔊	100 2T	🔊	50 2T	🔊	50 2T	LC
72 8121	€ 81,54 Ø 17,5	72 8121	€ 81,54 Ø 17,5	72 8121	€ 81,54 Ø 17,5	-		72 7084	€ 75,17 Ø 17,5	-		72 8121	€ 81,54 Ø 17,5	72 8121	€ 81,54 Ø 17,5
1611042	€ 118,04	1611042	€ 118,04	1611042	€ 118,04	-		1611042	€ 118,04	-		1611042	€ 118,04	1611042	€ 118,04
1610995	€ 114,23	1610995	€ 114,23	1610995	€ 114,23	-		1610995	€ 114,23	-		1610995	€ 114,23	1610995	€ 114,23
1611026 *15*	€ 107,68	1611026 *15*	€ 107,68	1611026 *15*	€ 107,68	-		1611029	€ 96,77	1611430	€ 174,96	1611026 *15*	€ 107,68	1611026 *15*	€ 107,68
27 7731.C0	€ 48,95 VL12	27 7731.C0	€ 48,95 VL12	27 7731.C0	€ 48,95 VL12	-		27 7708.C0	€ 48,95 VL11	27 7731.C0	€ 48,95 VL12	27 7731.C0	€ 48,95 VL12	27 7731.C0	€ 48,95 VL12
27 7054.C0	€ 18,71	27 7054.C0	€ 18,71	27 7054.C0	€ 18,71	-		27 7054.C0	€ 18,71	27 7054.C0	€ 18,71	27 7054.C0	€ 18,71	27 7054.C0	€ 18,71
3215172	€ 120,00	3215172	€ 120,00	-		-		3216694	€ 122,00	-		-		-	
-		-		3216585	€ 87,00	-		3216582	€ 87,00	-		-		-	
1411407	€ 3,85	1411407	€ 3,85	1411406	€ 3,04	1412131	€ 4,57	1411778	€ 3,54	-		1411407	€ 3,85	1411407	€ 3,85
1414507	€ 5,30	1414507	€ 5,30	1414512	€ 4,30	-		1414497	€ 6,16	-		1414507	€ 5,30	1414507	€ 5,30
6714039	€ 57,67 z 13/44	6714039	€ 57,67 z 13/44	6714039	€ 57,67 z 13/44	6711297	€ 121,34 z 15/40	-		6711486	€ 76,18 z 15/42	67 7014	€ 68,44 z 15/41	67 7014	€ 68,44 z 15/41
-		-		-		-		6711135	€ 58,86 z 15/55	-		-		-	
2515482	€ 95,00	2515482	€ 95,00	-		-		2514521 *66*	€ 95,00	-		-		-	
-		-		-		-		-		-		-		-	
6215042	€ 5,72 1995->	6215042	€ 5,72 1996->	6215042	€ 5,72 1996->	-		6215042	€ 5,72	-		6215042	€ 5,72 1997->	6215042	€ 5,72 1997->
6215080	€ 6,00 1995->	6215080	€ 6,00 1996->	6215080	€ 6,00 1996->	-		6215080	€ 6,00	-		6215080	€ 6,00 1997->	6215080	€ 6,00 1997->
6215007	€ 11,96 1998->	6215007	€ 11,96 1996->	6215007	€ 11,96 1996->	-		6215007	€ 11,96	6211649	€ 15,00 2000->	6215007	€ 11,96 1997->	6215007	€ 11,96 1997->
-		6215042	€ 5,72 1996->	-		-		-		-		-		-	
-		6215080	€ 6,00 1996->	-		-		-		-		-		-	
-		6215007	€ 11,96 1996->	-		-		-		-		-		-	
6215802	€ 18,64 1995->	-		6215802	€ 18,64 1996->	-		-		-		6215802	€ 18,64 1997->	6215802	€ 18,64 1997->
6212603	€ 72,56 1995->	6212603	€ 72,56 1996->	-		-		-		-		-		-	
-		-		-		-		-		-		-		-	
46 7906	€ 140,92 RS3	46 7906	€ 140,92 RS3	46 7906	€ 140,92 RS3	-		-		46 7906	€ 140,92 RS3	46 7906	€ 140,92 RS3	46 7906	€ 140,92 RS3
-		-		-		-		-		-		-		-	
46 7589 € 221,96	4614223 € 430,00	46 7589 € 221,96	4614223 € 430,00	46 7589	€ 221,96 RS24	-		-		46 7589	€ 221,96 RS24	46 7589	€ 221,96 RS24	46 7589	€ 221,96 RS24
-		-		-		-		-		-		-		-	
-		-		-		-		-		-		-		-	
-		-		-		-		-		-		-		-	



MALOSSI

Scooter 2T

with ENGINE 

APRILIA

SPORTCITY ONE
STREET
euro 2SR
1994->SR (carb.)
2004->

SR DITECH

(PIAGGIO)

(APRILIA)

⚠ ATTENTION: ONLY FOR vehicles WITHOUT IMMOBILIZER KEY		50 2T	50 2T	50 2T	LC	50 2T	LC
	CYLINDER+HEAD CAST-IRON Ø 40	31 8520	31 8562 1	31 8523	-		
	(pin) ALUMINIUM Ø 40-41	€124,91 Ø 40 (12)	€120,74 Ø 40 (10)	€164,21 Ø 40 (12)			
	CYLINDER+HEAD	31 6926	31 7083 1	31 7353	3112043		
	(pin) CAST-IRON Ø 47	€120,25 Ø 47 (12)	€114,25 Ø 47 (10)	€176,03 Ø 47 (12)	€308,14 Ø 47 (12)		
	CYLINDER CAST-IRON Ø 47-57,5	31 6915	31 7002	-	-		
for ORIGINAL HEAD ALUM. Ø 47>57,5	€100,86 Ø 47 (12)	€97,90 Ø 47 (10)					
HEAD HTSR	38 7118	38 7246	-	-			
for Malossi CYLINDER	€37,45 Ø 47	€37,47 Ø 47					
CYLINDER+HEAD MHR Replica ALUMINIUM	31 8463	31 8437 1	31 8466	-			
(pin) Ø 47	€207,00 Ø 47 (12)	€207,00 Ø 47 (10)	€239,46 Ø 47 (12)				
	CRANKSHAFTS RHQ	-	53 7891	-	-		
	PIN Ø 10		€175,50				
	CRANKSHAFTS RHQ	53 7600	53 8009	53 7600	5312582		
	PIN Ø 12	€175,50	€175,50	€175,50	€280,16		
	RADIAL ROLLER BEARING	6614105E	PG.473	6614105E	-		
FOR CRANKSHAFT	PG.473 €43,00		€43,00				
	ELECTRONIC CONTROLLER	5513195 *35*	55 8133	5513195 *35*	PG.418		
	⚠	€92,82	€50,14	€92,82			
	ELECTRONIC CONTROLLER	5513196 *35*	55 8676	5513196 *35*	-		
	RPM CONTROL	€140,51	€97,59	€140,51			
	MULTIVAR	51 9019	51 7075	51 9019	5111561		
	VARIATOR	€61,80	€58,71	€61,80	€59,36		
	X SPECIAL BELT	61 9830	6112730	61 9831	6111295		
	BELT	€17,34	€14,36	€19,49	€17,71		
	X K BELT	61 9535	6112729	6114118	6111294		
BELT	€28,72	€25,23	€38,25	€28,38			
	HTRoll	66 9420.M0	66 9823.M0	66 9420.M0	66 9823.M0		
	ROLLERS FOR MULTIVAR	€10,00 gr.07,2	€9,50 gr.07	€10,00 gr.07,2	€9,50 gr.07		
	HTRoll	66 9420.I0	66 9417.F0	66 9420.N0	-		
ROLLERS FOR ORIGINAL VARIATOR	€10,00 gr.06,5	€7,24 gr.05,4	€10,00 gr.07,5				
	VENTILVAR	-	61 7152	-	-		
FIXED HALF-PULLEY			€21,71				
	VARIABLE-SPEED DRIVE ADJUSTER SPRING	PG.438	PG.438	PG.438	PG.438		
FOR VARIATOR							
	TORSION CONTROLLER	2512828	2512827	2512828	-		
	ANTIFRICTION FIFTH WHEEL	€4,45	€4,45	€4,45			
	TORQUE DRIVER	61 9100	61 8312 Ø 33 €85,57	61 9100	-		
	MOBILE DRIVEN SPLIT PULLEY	€85,57	61 9223 Ø 34 €85,57	€85,57			
	FLY CLUTCH	52 8797	52 8796 Ø 105 €53,26	52 8797	52 9450		
	NOT ADJUSTABLE CLUTCH	€47,30	52 9450 Ø 107 €47,30	€47,30	€47,30		
	DELTA CLUTCH	52 7880	52 7643 Ø 105 €77,89	52 7880	52 9451		
ADJUSTABLE CLUTCH	€77,89	52 9451 Ø 107 €77,89	€77,89	€77,89			
	CLUTCH BELL	7711115	-	7711115	-		
	CLUTCH BELL (SMOOTH RING)	€22,60 Ø 107		€22,60 Ø 107			
	WING CLUTCH BELL	7711207	-	7711207	-		
	CLUTCH BELL (FINNED RING)	€33,45 Ø 107		€33,45 Ø 107			
	FLY SYSTEM	5214111	-	5214111	-		
	CLUTCH BELL + NOT ADJUSTABLE CLUTCH	€63,00 Ø 107		€63,00 Ø 107			
	DELTA SYSTEM	5214110	-	5214110	-		
	CLUTCH BELL + ADJUSTABLE CLUTCH	€93,84 Ø 107		€93,84 Ø 107			
	SPORT SPRINGS	29 8746	29 8746	29 8746	29 8746		
	FOR FLY / DELTA CLUTCH	€14,50	€14,50	€14,50	€14,50		
	MHR SPRINGS	29 8747	29 8747	29 8747	29 8747		
	FOR FLY / DELTA CLUTCH	€19,40	€19,40	€19,40	€19,40		
	SPRINGS Ø INTERNAL CLUTCH BELL 105-107	29 7454	29 7714 Ø 105 €13,80	29 7454	-		
FOR ORIGINAL CLUTCH	€16,20	29 9605 Ø 107 €16,20	€16,20				
MUELLES Ø INTERNAL CLUTCH BELL 112	-	29 7715	-	-			
FOR ORIGINAL CLUTCH		€16,20 Ø 112					

35 - IT CAN BE ASSEMBLED WITH NO MODIFICATION to the original system, EVEN ON vehicles PRODUCED 2001->

36 - IT CAN BE ASSEMBLED WITH NO MODIFICATION to the original system

PG - SPECIFICATIONS on the PAGE indicated in the TITLE of the LINE

APRILIA

203

SR DITECH GP1	SR MOTARD euro 2	SR NETSCAPER	SR R (carb.)	SR R FACTORY	SR RACING	SR REPLICA <-1999	SR REPLICA 2000->
(PIAGGIO C361M)		(MINARELLI)	(PIAGGIO)	(PIAGGIO C361M)	(MINARELLI)		(APRILIA)
50 2T LC	50 2T	50 2T LC	50 2T LC	50 2T LC	50 2T LC	50 2T LC	50 2T LC
-	31 8520 € 124,91 Ø 40 (12)	31 8556 1 € 161,98 Ø 40 (10)	31 8523 € 164,21 Ø 40 (12)	-	31 8556 1 € 161,98 Ø 40 (10)	31 8556 1 € 161,98 Ø 40 (10)	-
3112044 € 305,23 Ø 47 (12)	31 6926 € 120,25 Ø 47 (12)	31 8284 1 € 152,41 Ø 47 (10)	31 7353 € 176,03 Ø 47 (12)	3112044 € 305,23 Ø 47 (12)	31 8284 1 € 152,41 Ø 47 (10)	31 8284 1 € 152,41 Ø 47 (10)	31 9541 € 166,72 Ø 47 (12)
-	31 6915 € 100,86 Ø 47 (12)	-	-	-	-	-	-
-	38 7118 € 37,45 Ø 47	-	-	-	-	-	-
-	31 8463 € 207,00 Ø 47 (12)	31 8430 1 € 228,06 Ø 47 (10)	31 8466 € 239,46 Ø 47 (12)	-	31 8430 1 € 228,06 Ø 47 (10)	31 8430 1 € 228,06 Ø 47 (10)	-
-	-	53 7891 € 175,50	-	-	53 7891 € 175,50	53 7891 € 175,50	-
5312331 € 301,56	53 7600 € 175,50	53 8009 € 175,50	53 7600 € 175,50	5312331 € 301,56	53 8009 € 175,50	53 8009 € 175,50	-
-	6614105E € 43,00	PG.473	6614105E € 43,00	-	PG.473	PG.473	-
PG.418	5513195 *36* € 92,82	55 8133 € 50,14	5513195 *35* € 92,82	PG.418	55 8133 € 50,14	55 8133 € 50,14	-
-	5513196 *36* € 140,51	55 8676 € 97,59	5513196 *35* € 140,51	-	55 8676 € 97,59	55 8676 € 97,59	-
51 9019 € 61,80	51 9019 € 61,80	51 7075 € 58,71	51 9019 € 61,80	51 9019 € 61,80	51 7075 € 58,71	51 7075 *PG* € 58,71	511561 € 59,36
61 9831 € 19,49	61 9831 € 19,49	6112730 € 14,36	61 9831 € 19,49	61 9831 € 19,49	6112730 € 14,36	6112730 € 14,36	6111295 € 17,71
6114118 € 38,25	6114118 € 38,25	6112729 € 25,23	6114118 € 38,25	6114118 € 38,25	6112729 € 25,23	6112729 € 25,23	6111294 € 28,38
66 9420.M0 € 10,00 gr.07,2	66 9420.M0 € 10,00 gr.07,2	66 9823.M0 € 9,50 gr.07	66 9420.M0 € 10,00 gr.07,2	66 9420.M0 € 10,00 gr.07,2	66 9823.M0 € 9,50 gr.07	66 9823.M0 € 9,50 gr.07	66 9823.M0 € 9,50 gr.07
-	66 9420.N0 € 10,00 gr.07,5	66 9417.F0 € 7,24 gr.05,4	66 9420.N0 € 10,00 gr.07,5	-	66 9417.F0 € 7,24 gr.05,4	66 9417.F0 € 7,24 gr.05,4	66 9999.G0 € 8,50 gr.07
-	-	61 7152 € 21,71	-	-	61 7152 € 21,71	61 7152 € 21,71	-
-	PG.438	PG.438	PG.438	-	PG.438	PG.438	PG.438
2512828 € 4,45	2512828 € 4,45	2512827 € 4,45	2512828 € 4,45	2512828 € 4,45	2512827 € 4,45	2512827 € 4,45	-
61 9100 € 85,57	61 9100 € 85,57	61 9223 € 85,57	61 9100 € 85,57	61 9100 € 85,57	61 9223 € 85,57	61 8312 Ø 33 € 85,57 61 9223 Ø 34 € 85,57	-
52 8797 € 47,30	52 8797 € 47,30	52 9450 € 47,30	52 8797 € 47,30	52 8797 € 47,30	52 9450 € 47,30	52 8796 Ø 105 € 53,26 52 9450 Ø 107 € 47,30	52 9450 € 47,30
52 7880 € 77,89	52 7880 € 77,89	52 9451 € 77,89	52 7880 € 77,89	52 7880 € 77,89	52 9451 € 77,89	52 7643 Ø 105 € 77,89 52 9451 Ø 107 € 77,89	52 9451 € 77,89
7711115 € 22,60 Ø 107	7711115 € 22,60 Ø 107	7711124 € 22,60 Ø 107	7711115 € 22,60 Ø 107	7711115 € 22,60 Ø 107	7711124 € 22,60 Ø 107	-	-
7711207 € 33,45 Ø 107	7711207 € 33,45 Ø 107	7711166 € 33,45 Ø 107	7711207 € 33,45 Ø 107	7711207 € 33,45 Ø 107	7711166 € 33,45 Ø 107	-	-
5214111 € 63,00 Ø 107	5214111 € 63,00 Ø 107	5214112 € 63,00 Ø 107	5214111 € 63,00 Ø 107	5214111 € 63,00 Ø 107	5214112 € 63,00 Ø 107	-	-
5214110 € 93,84 Ø 107	5214110 € 93,84 Ø 107	5214113 € 93,84 Ø 107	5214110 € 93,84 Ø 107	5214110 € 93,84 Ø 107	5214113 € 93,84 Ø 107	-	-
29 8746 € 14,50	29 8746 € 14,50	29 8746 € 14,50	29 8746 € 14,50	29 8746 € 14,50	29 8746 € 14,50	29 8746 € 14,50	29 8746 € 14,50
29 8747 € 19,40	29 8747 € 19,40	29 8747 € 19,40	29 8747 € 19,40	29 8747 € 19,40	29 8747 € 19,40	29 8747 € 19,40	29 8747 € 19,40
-	29 7454 € 16,20	29 7714 Ø 105 € 13,80 29 9605 Ø 107 € 16,20	29 7454 € 16,20	-	29 7714 Ø 105 € 13,80 29 9605 Ø 107 € 16,20	29 7714 Ø 105 € 13,80 29 9605 Ø 107 € 16,20	29 7454 € 16,20
-	-	29 7715 € 16,20 Ø 112	-	-	29 7715 € 16,20 Ø 112	29 7715 € 16,20 Ø 112	-

SCOOTER 2T



MALOSSI

Scooter 2T

with ENGINE 

APRILIA

SPORTCITY ONE
STREET
euro 2SR
1994->SR (carb.)
2004->

SR DITECH

(PIAGGIO)

(APRILIA)

50 2T



50 2T

















50 2T

LC

50 2T

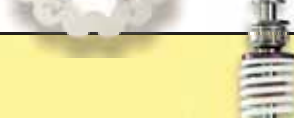
LC

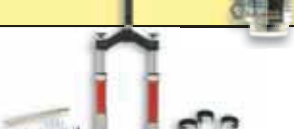
CHECK "TYPE" SPECIFICATION (HOMOLOGATION MARK)		50 2T	50 2T	50 2T	50 2T
	CARBURETTOR	72 7084 € 75,17 Ø 17,5	72 8121 € 81,54 Ø 17,5	72 7084 € 75,17 Ø 17,5	-
	CARBURETTOR KIT Ø 19	1611042 € 118,04	1611042 € 118,04	1611040 € 118,04	-
	CARBURETTOR KIT Ø 21	1610995 € 114,23	1610995 € 114,23	1610997 € 114,23	-
	CARBURETTOR KIT Ø 22	1611029 € 96,77	1611026 *15* € 107,68	1611029 € 96,77	-
	REED VALVE CARBON FIBRE	27 7708.C0 € 48,95 VL11	27 7731.C0 € 48,95 VL12	27 7708.C0 € 48,95 VL11	27 7731.C0 € 48,95 VL12
	PETALS SET FOR ORIGINAL REED VALVE	27 7054.C0 € 18,71	27 7054.C0 € 18,71	27 7054.C0 € 18,71	27 7054.C0 € 18,71
	ART OF PERFORMANCE / FLIP HOMOLOGATED 	PG. 426 3215167 € 175,70 3216692 € 122,00	3215172 € 120,00	3216694 € 122,00	3215178 € 120,00
	WILD LION HOMOLOGATED 	PG. 424 -	3216587 € 87,00	3216582 € 87,00	-
	RED SPONGE FOR ORIGINAL AIR BOX	1411778 € 3,54	1411407 € 3,85	1412130 € 5,69	1412130 € 5,69
	DOUBLE RED SPONGE FOR ORIGINAL AIR BOX	1414497 € 6,16	1414507 € 5,30	1414509 € 7,73	1414509 € 7,73
	GEARS HTQ PRIMARY	-	6714039 € 57,67 z 13/44	67 9080 z 14/39 € 60,41 6713339 z 15/38 € 61,71	6711297 € 121,34 z 15/40
	GEARS HTQ SECONDARY	PG. 478 6711135 *PG* € 58,86 z 15/55	6714774 z 15/42 € 67,32 6714775 z 14/43 € 67,32	67 9966 *PG* € 65,00 z 13/48	-
	ROLLER CRANKCASE	2514521 *66* € 95,00	2515482 € 95,00	2514521 *66* € 95,00	-
	SCREEN	-	-	-	-
	BRAKE PADS FRONT	-	6215043 € 5,80 <-1996	6215043 € 5,80	6215043 € 5,80 2000->
	BRAKE PADS MHR FRONT	-	62 9083 € 6,20 <-1996	62 9083 € 6,20	62 9083 € 6,20 2000->
	BRAKE PADS MHR SYNT FRONT	-	6215008 € 11,96 <-1996	6215008 € 11,96	6215008 € 11,96 2000->
	BRAKE PADS REAR	-	-	-	-
	BRAKE PADS MHR REAR	-	-	-	-
	BRAKE PADS MHR SYNT REAR	-	-	6215019 € 16,64	6215019 € 16,64 2000->
	BRAKE POWER REAR	-	6215802 € 18,64 <-1996	-	-
	BRAKE SHOES FRONT	-	-	-	-
	WHOOP DISC FRONT	-	6212603 € 72,56 <-1996	6212603 € 72,56	6212603 € 72,56 2000->
	WHOOP DISC REAR	-	-	-	6212603 € 72,56 2000->
	RS1 - RS3 REAR SHOCK ABSORBER	-	46 7906 € 140,92	4613054 € 147,80	-
	RS24 - RS24/10 FRONT SHOCK ABSORBER	-	-	-	-
	RS24 - RS24/10 - RS24/10-R REAR SHOCK ABSORBER	-	46 7589 € 221,96 4614223 € 430,00	4613055 € 217,60 4614223 € 430,00	-
	RS24 FRONT + REAR	-	-	-	-
	HORQUILLA F32S FORK STEMS Ø 32	-	-	-	-
	HORQUILLA F37R MHR FORK STEMS Ø 37	-	-	-	-

15 - WITH manual choke

66 - NOT to be used on VEHICLE WITH ORIGINAL PRIMARY GEARS

PG - SPECIFICATIONS on the PAGE indicated in the TITLE of the LINE

APRILIA

205

SR DITECH GP1	SR MOTARD euro 2	SR NETSCAPER	SR R (carb.)	SR R FACTORY	SR RACING	SR REPLICA <-1999	SR REPLICA 2000->
(PIAGGIO C361M)		(MINARELLI)	(PIAGGIO)	(PIAGGIO C361M)	(MINARELLI)		(APRILIA)
50 2T LC	50 2T  LC	50 2T LC	50 2T LC	50 2T LC	50 2T LC	50 2T LC	50 2T LC
-	72 7084 € 75,17 Ø 17,5	72 8121 € 81,54 Ø 17,5	72 7084 € 75,17 Ø 17,5	-	72 8121 € 81,54 Ø 17,5	72 8121 € 81,54 Ø 17,5	-
-	1611040 € 118,04	1611042 € 118,04	1611040 € 118,04	-	1611042 € 118,04	1611042 € 118,04	1611039 € 124,50
-	1610997 € 114,23	1610995 € 114,23	1610997 € 114,23	-	1610995 € 114,23	1610995 € 114,23	-
-	1611029 € 96,77	1611026 *15* € 107,68	1611029 € 96,77	-	1611026 *15* € 107,68	1611026 *15* € 107,68	-
27 7708.CO € 48,95 VL11	27 7708.CO € 48,95 VL11	27 7731.CO € 48,95 VL12	27 7708.CO € 48,95 VL11	27 7708.CO € 48,95 VL11	27 7731.CO € 48,95 VL12	27 7731.CO € 48,95 VL12	27 7731.CO € 48,95 VL12
27 7054.CO € 18,71	27 7054.CO € 18,71	27 7054.CO € 18,71	27 7054.CO € 18,71	27 7054.CO € 18,71	27 7054.CO € 18,71	27 7054.CO € 18,71	27 7054.CO € 18,71
3216694 € 122,00	3216988 € 122,00	3215172 € 120,00	3216694 € 122,00	3216694 € 122,00	3215172 € 120,00	3215172 € 120,00	-
3216582 € 87,00	-	3216587 € 87,00	3216582 € 87,00	3216582 € 87,00	3216587 € 87,00	3216587 € 87,00	-
1412130 € 5,69	1411778 € 3,54	1411407 € 3,85	1413417 € 17,79	1413417 € 17,79	1411407 € 3,85	1411407 € 3,85	1412130 € 5,69
1414509 € 7,73	1414497 € 6,16	1414507 € 5,30	-	-	1414507 € 5,30	1414507 € 5,30	1414509 € 7,73
67 9080 z 14/39 € 60,41 6713339 z 15/38 € 61,71	-	6714039 € 57,67 z 13/44	67 9080 z 14/39 € 60,41 6713339 z 15/38 € 61,71	67 9080 z 14/39 € 60,41 6713339 z 15/38 € 61,71	6714039 € 57,67 z 13/44	6714039 € 57,67 z 13/44	6711297 € 121,34 z 15/40
-	-	6714774 z 15/42 € 67,32 6714775 z 14/43 € 67,32	67 9966 € 65,00 z 13/48	-	6714774 z 15/42 € 67,32 6714775 z 14/43 € 67,32	6714774 z 15/42 € 67,32 6714775 z 14/43 € 67,32	-
2514521 *66* € 95,00	2514521 *66* € 95,00	2515482 € 95,00	2514521 *66* € 95,00	2514521 *66* € 95,00	2515482 € 95,00	2515482 € 95,00	-
-	-	-	-	-	-	-	-
6215043 € 5,80	-	6215042 1997-> € 5,72 6215043 1993->96 € 5,80	6215043 € 5,80	6215043 € 5,80	6215042 1997-> € 5,72 6215043 1993->96 € 5,80	6215043 € 5,80 1993->	6215042 € 5,72 2000->
62 9083 € 6,20	-	62 9083 1993->96 € 6,20 6215080 1997-> € 6,00	62 9083 € 6,20	62 9083 € 6,20	62 9083 1993->96 € 6,20 6215080 1997-> € 6,00	62 9083 € 6,20 1993->	6215080 € 6,00 2000->
6215008 € 11,96	-	6215007 1997-> € 11,96 6215008 1993->96 € 11,96	6215008 € 11,96	6215008 € 11,96	6215007 1997-> € 11,96 6215008 1993->96 € 11,96	6215008 € 11,96 1993->	6215007 € 11,96 2000->
-	-	6215042 € 5,72 1997->	-	-	6215042 € 5,72 1997->	-	-
-	-	6215080 € 6,00 1997->	-	-	6215080 € 6,00 1997->	-	-
6215019 € 16,64	-	6215007 € 11,96 1997->	6215019 € 16,64	6215019 € 16,64	6215007 € 11,96 1997->	-	6215019 € 16,64 2000->
-	-	6215802 € 18,64 1993->96	-	-	-	6215802 € 18,64 1993->	-
6212603 € 72,56	-	6212603 € 72,56 1993->	6212603 € 72,56	6212603 € 72,56	6212603 € 72,56 1993->	6212603 € 72,56 1993->	6212603 € 72,56 2000->
-	-	-	-	-	-	-	6212603 € 72,56 2000->
4613054 € 147,80	4615432 € 94,86 46 7908 € 140,92	46 7906 € 140,92 RS3	4613054 € 147,80	4613054 € 147,80	46 7906 € 140,92	46 7906 € 140,92	-
-	-	-	-	-	-	-	-
4613055 217,60 4614223 € 430,00	46 8308 € 248,50	46 7589 € 221,96 4614223 € 430,00	4613055 € 217,60 4614223 € 430,00	4613055 € 217,60 4614223 € 430,00	46 7589 € 221,96 4614223 € 430,00	46 7589 € 221,96 4614223 € 430,00	-
-	-	-	-	-	-	-	-
-	46 9550 € 591,80	-	-	-	-	-	-
-	-	-	-	-	-	-	-

SCOOTER 2T



MALOSSI

Scooter 2T

with ENGINE 

APRILIA		BENELLI	
SR STEALTH	SR WWW	491 GT	491 SPORT
(MINARELLI)		(MINARELLI)	(MINARELLI)

(▲) ATTENTION: ONLY FOR vehicles WITHOUT IMMOBILIZER KEY			50 2T	LC	50 2T		50 2T		50 2T	LC
	CYLINDER+HEAD	CAST-IRON Ø 40	31 8556	1	31 8562	1	31 8562	1	31 8556	1
	(pin)	ALUMINIUM Ø 40-41	€161,98	Ø 40 (10)	€120,74	Ø 40 (10)	€120,74	Ø 40 (10)	€161,98	Ø 40 (10)
	CYLINDER+HEAD		31 8284	1	31 7083	1	31 7083	1	31 8284	1
	(pin)	CAST-IRON Ø 47	€152,41	Ø 47 (10)	€114,25	Ø 47 (10)	€114,25	Ø 47 (10)	€152,41	Ø 47 (10)
	CYLINDER	CAST-IRON Ø 47-57,5	-		31 7002		31 7002		-	
	for ORIGINAL HEAD	ALUM. Ø 47>57,5	-		€97,90	Ø 47 (10)	€97,90	Ø 47 (10)	-	
	HEAD HTSR		-		38 7246		38 7246		-	
	for Malossi CYLINDER		-		€37,47	Ø 47	€37,47	Ø 47	-	
	CYLINDER+HEAD MHR Replica	ALUMINIUM	31 8430	1	31 8437	1	31 8437	1	31 8430	1
	(pin)	Ø 47	€228,06	Ø 47 (10)	€207,00	Ø 47 (10)	€207,00	Ø 47 (10)	€228,06	Ø 47 (10)
	CRANKSHAFTS RHQ		53 7891		53 7891		53 7891		53 7891	
		PIN Ø 10	€175,50		€175,50		€175,50		€175,50	
	CRANKSHAFTS RHQ		53 8009		53 8009		53 8009		53 8009	
		PIN Ø 12	€175,50		€175,50		€175,50		€175,50	
	RADIAL ROLLER BEARING		PG.473		PG.473		PG.473		PG.473	
	FOR CRANKSHAFT									
	ELECTRONIC CONTROLLER		55 8133		55 8133		55 8133	*27*	55 8133	*27*
			€50,14		€50,14		€50,14		€50,14	
	ELECTRONIC CONTROLLER RPM CONTROL		55 8676		55 8676		55 8676	*32*	55 8676	*32*
			€97,59		€97,59		€97,59		€97,59	
	MULTIVAR		51 7075		51 7075		51 7075		51 7075	
	VARIATOR		€58,71		€58,71		€58,71		€58,71	
	X SPECIAL BELT		6112730		6112730		6112730		6112730	
	BELT		€14,36		€14,36		€14,36		€14,36	
	X K BELT		6112729		6112729		6112729		6112729	
	BELT		€25,23		€25,23		€25,23		€25,23	
	HTRoII		66 9823.M0		66 9823.M0		66 9823.M0		66 9823.M0	
	ROLLERS FOR MULTIVAR		€9,50	gr.07	€9,50	gr.07	€9,50	gr.07	€9,50	gr.07
	HTRoII		66 9417.FO		66 9417.HO		66 9417.HO		66 9417.I0	
	ROLLERS FOR ORIGINAL VARIATOR		€7,24	gr.05,4	€7,24	gr.06,5	€7,24	gr.06,5	€7,24	gr.06,8
	VENTILVAR		61 7152		61 7152		61 7152		61 7152	
	FIXED HALF-PULLEY		€21,71		€21,71		€21,71		€21,71	
	VARIABLE-SPEED DRIVE ADJUSTER SPRING		PG.438		PG.438		PG.438		PG.438	
	FOR VARIATOR									
	TORSION CONTROLLER		2512827		2512827		2512827		2512827	
	ANTIFRICTION FIFTH WHEEL		€4,45		€4,45		€4,45		€4,45	
	TORQUE DRIVER		61 9223		61 9223		61 8312 Ø 33 €85,57		61 8312 Ø 33 €85,57	
	MOBILE DRIVEN SPLIT PULLEY		€85,57		€85,57		61 9223 Ø 34 €85,57		61 9223 Ø 34 €85,57	
	FLY CLUTCH		52 9450		52 9450		52 8796 Ø 105 €53,26		52 8796 Ø 105 €53,26	
	NOT ADJUSTABLE CLUTCH		€47,30		€47,30		52 9450 Ø 107 €47,30		52 9450 Ø 107 €47,30	
	DELTA CLUTCH		52 9451		52 9451		52 7643 Ø 105 €77,89		52 7643 Ø 105 €77,89	
	ADJUSTABLE CLUTCH		€77,89		€77,89		52 9451 Ø 107 €77,89		52 9451 Ø 107 €77,89	
	CLUTCH BELL		7711124		7711124		7711124		7711124	
	CLUTCH BELL (SMOOTH RING)		€22,60	Ø 107	€22,60	Ø 107	€22,60	Ø 107	€22,60	Ø 107
	WING CLUTCH BELL		7711166		7711166		7711166		7711166	
	CLUTCH BELL (FINNED RING)		€33,45	Ø 107	€33,45	Ø 107	€33,45	Ø 107	€33,45	Ø 107
	FLY SYSTEM		5214112		5214112		5214112		5214112	
	CLUTCH BELL + NOT ADJUSTABLE CLUTCH		€63,00	Ø 107	€63,00	Ø 107	€63,00	Ø 107	€63,00	Ø 107
	DELTA SYSTEM		5214113		5214113		5214113		5214113	
	CLUTCH BELL + ADJUSTABLE CLUTCH		€93,84	Ø 107	€93,84	Ø 107	€93,84	Ø 107	€93,84	Ø 107
	SPORT SPRINGS		29 8746		29 8746		29 8746		29 8746	
	FOR FLY / DELTA CLUTCH		€14,50		€14,50		€14,50		€14,50	
	MHR SPRINGS		29 8747		29 8747		29 8747		29 8747	
	FOR FLY / DELTA CLUTCH		€19,40		€19,40		€19,40		€19,40	
	SPRINGS Ø INTERNAL CLUTCH BELL 105-107		29 7714 Ø 105	€13,80	29 7714 Ø 105	€13,80	29 7714 Ø 105	€13,80	29 7714 Ø 105	€13,80
	FOR ORIGINAL CLUTCH		29 9605 Ø 107	€16,20	29 9605 Ø 107	€16,20	29 9605 Ø 107	€16,20	29 9605 Ø 107	€16,20
	MUELLES Ø INTERNAL CLUTCH BELL 112		29 7715		29 7715		29 7715		29 7715	
	FOR ORIGINAL CLUTCH		€16,20	Ø 112	€16,20	Ø 112	€16,20	Ø 112	€16,20	Ø 112

18 - To be assembled EXCLUSIVELY with MALOSSI EXHAUST SYSTEMS

27 - For vehicles with YAMAHA FLYWHEEL

32 - For vehicles with YAMAHA FLYWHEEL - If it is a DUCATI : TC UNIT K15 +BOBINA / RPM CONTROL 55 8765 € 127,73

PG - SPECIFICATIONS on the PAGE indicated in the TITLE of the LINE

BENELLI							BETA
K2	K2	K2	NAKED	PEPE	PEPE LX euro 2	QuattronoveX euro 2	ARK
					(QJ1E40QMB-4)		
50 2T	50 2T	100 2T	50 2T	50 2T	50 2T	50 2T	50 2T
31 8562 1 €120,74 Ø 40 (10)	31 8556 1 €161,98 Ø 40 (10)	-	31 8562 1 €120,74 Ø 40 (10)	31 8562 1 €120,74 Ø 40 (10)	3113865 *18* €120,74 Ø 40 (12)	3113865 *18* €120,74 Ø 40 (12)	31 8562 1 €120,74 Ø 40 (10)
31 7083 1 €114,25 Ø 47 (10)	31 8284 1 €152,41 Ø 47 (10)	-	31 7083 1 €114,25 Ø 47 (10)	31 7083 1 €114,25 Ø 47 (10)	3113066 *18* €117,81 Ø 47 (12)	3113066 *18* €117,81 Ø 47 (12)	31 7083 1 €114,25 Ø 47 (10)
31 7002 €97,90 Ø 47 (10)	-	3111374 €167,85 Ø 57,5 (14)	31 7002 €97,90 Ø 47 (10)	31 7002 €97,90 Ø 47 (10)	3113067 €97,90 Ø 47 (12)	3113067 €97,90 Ø 47 (12)	31 7002 €97,90 Ø 47 (10)
38 7246 €37,47 Ø 47	-	-	38 7246 €37,47 Ø 47	38 7246 €37,47 Ø 47	38 7246 €37,47 Ø 47	38 7246 €37,47 Ø 47	38 7246 €37,47 Ø 47
31 8437 1 €207,00 Ø 47 (10)	31 8430 1 €228,06 Ø 47 (10)	-	31 8437 1 €207,00 Ø 47 (10)	31 8437 1 €207,00 Ø 47 (10)	-	-	31 8437 1 €207,00 Ø 47 (10)
53 7891 €175,50	53 7891 €175,50	-	53 7891 €175,50	53 7891 €175,50	-	-	53 7891 €175,50
53 8009 €175,50	53 8009 €175,50	-	53 8009 €175,50	53 8009 €175,50	5313587 €175,50	5313587 €175,50	53 8009 €175,50
PG.473	PG.473	-	PG.473	PG.473	PG.473	-	PG.473
55 8133 *27* €50,14	55 8133 *27* €50,14	-	55 8133 *27* €50,14	55 8133 *27* €50,14	-	-	-
55 8676 *32* €97,59	55 8676 *32* €97,59	-	55 8676 *32* €97,59	55 8676 *32* €97,59	-	-	55 8765 €127,73
51 7075 €58,71	51 7075 €58,71	5111380 €66,95	51 7075 €58,71	51 7075 €58,71	5113363 €60,00	5113363 €60,00	51 7075 €58,71
6112730 €14,36	6112730 €14,36	-	6112730 €14,36	6112730 €14,36	61 9832 €17,04	61 9832 €17,04	6112730 €14,36
6112729 €25,23	6112729 €25,23	6112959 €28,51	6112729 €25,23	6112729 €25,23	61 7587 €28,25	61 7587 €28,25	6112729 €25,23
66 9823.MO €9,50 gr.07	66 9823.MO €9,50 gr.07	66 9420.JO €10,00 gr.11	66 9823.MO €9,50 gr.07	66 9823.MO €9,50 gr.07	66 9823.LO gr.06 €9,50 66 9823.OO gr.09 €9,50	66 9823.LO gr.06 €9,50 66 9823.OO gr.09 €9,50	66 9823.MO €9,50 gr.07
66 9417.I0 €7,24 gr.06,8	66 9417.I0 €7,24 gr.06,8	66 9417.N0 €7,24 gr.08,3	66 9417.I0 €7,24 gr.06,8	66 9417.I0 €7,24 gr.06,8	66 9417.D0 €7,24 gr.04,2	66 9417.G0 €7,24 gr.06	66 9417.F0 €7,24 gr.05,4
61 7152 €21,71	61 7152 €21,71	-	61 7152 €21,71	61 7152 €21,71	61 7151 €21,28	61 7151 €21,28	61 7152 €21,71
PG.438	PG.438	2911388.Y0 *PG* €10,71	PG.438	PG.438	PG.438	PG.438	PG.438
2512827 €4,45	2512827 €4,45	2512827 €4,45	2512827 €4,45	2512827 €4,45	-	-	2512827 €4,45
61 8312 Ø 33 €85,57 61 9223 Ø 34 €85,57	61 8312 Ø 33 €85,57 61 9223 Ø 34 €85,57	61 8312 €85,57	61 8312 Ø 33 €85,57 61 9223 Ø 34 €85,57	61 8312 Ø 33 €85,57 61 9223 Ø 34 €85,57	61 8312 €85,57	61 8312 €85,57	61 8312 Ø 33 €85,57 61 9223 Ø 34 €85,57
52 9450 €47,30	52 9450 €47,30	52 8798 €47,30	52 9450 €47,30	52 8796 Ø 105 €53,26 52 9450 Ø 107 €47,30	52 8798 €47,30	52 8798 €47,30	52 8796 Ø 105 €53,26 52 9450 Ø 107 €47,30
52 9451 €77,89	52 9451 €77,89	52 7879 €77,89	52 9451 €77,89	52 7643 Ø 105 €77,89 52 9451 Ø 107 €77,89	52 7879 €77,89	52 7879 €77,89	52 7643 Ø 105 €77,89 52 9451 Ø 107 €77,89
7711124 €22,60 Ø 107	7711124 €22,60 Ø 107	-	7711124 €22,60 Ø 107	7711124 €22,60 Ø 107	-	-	7711124 €22,60 Ø 107
7711166 €33,45 Ø 107	7711166 €33,45 Ø 107	-	7711166 €33,45 Ø 107	7711166 €33,45 Ø 107	-	-	7711166 €33,45 Ø 107
5214112 €63,00 Ø 107	5214112 €63,00 Ø 107	-	5214112 €63,00 Ø 107	5214112 €63,00 Ø 107	-	-	5214112 €63,00 Ø 107
5214113 €93,84 Ø 107	5214113 €93,84 Ø 107	-	5214113 €93,84 Ø 107	5214113 €93,84 Ø 107	-	-	5214113 €93,84 Ø 107
29 8746 €14,50	29 8746 €14,50	29 8746 €14,50	29 8746 €14,50	29 8746 €14,50	29 8746 €14,50	29 8746 €14,50	29 8746 €14,50
29 8747 €19,40	29 8747 €19,40	29 8747 €19,40	29 8747 €19,40	29 8747 €19,40	29 8747 €19,40	29 8747 €19,40	29 8747 €19,40
29 7714 Ø 105 €13,80 29 9605 Ø 107 €16,20	29 7714 Ø 105 €13,80 29 9605 Ø 107 €16,20	29 7715 €16,20	29 7714 Ø 105 €13,80 29 9605 Ø 107 €16,20	29 7714 Ø 105 €13,80 29 9605 Ø 107 €16,20	2913851 €15,50	2913851 €15,50	29 7714 Ø 105 €13,80 29 9605 Ø 107 €16,20
29 7715 €16,20 Ø 112	29 7715 €16,20 Ø 112	-	29 7715 €16,20 Ø 112	29 7715 €16,20 Ø 112	-	-	29 7715 €16,20 Ø 112



MALOSSİ

Scooter 2T

with ENGINE 

APRILIA

BENELLI

SR STEALTH

SR WWW

491 GT

491 SPORT

(MINARELLI)

(MINARELLI)

(MINARELLI)

50 2T

LC

50 2T

















50 2T



50 2T

LC

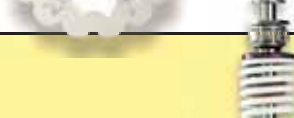
(■) CHECK "TYPE" SPECIFICATION (HOMOLOGATION MARK)

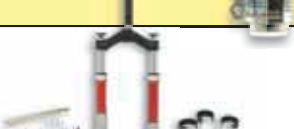
	CARBURETTOR		72 8121 € 81,54 Ø 17,5	72 8121 € 81,54 Ø 17,5	72 9215 € 78,76 Ø 17,5	72 9215 € 78,76 Ø 17,5
	CARBURETTOR KIT	Ø 19	1611042 € 118,04	1611042 € 118,04	1611042 € 118,04	1611042 € 118,04
	CARBURETTOR KIT	Ø 21	1610995 € 114,23	1610995 € 114,23	1610995 € 114,23	1610995 € 114,23
	CARBURETTOR KIT	Ø 22	1611026 *15* € 107,68	1611026 *15* € 107,68	1611031 € 120,28	1611031 € 120,28
	REED VALVE CARBON FIBRE		27 7731.C0 € 48,95 VL12	27 7731.C0 € 48,95 VL12	27 7731.C0 € 48,95 VL12	27 7731.C0 € 48,95 VL12
	PETALS SET FOR ORIGINAL REED VALVE		27 7054.C0 € 18,71	27 7054.C0 € 18,71	27 7054.C0 € 18,71	27 7054.C0 € 18,71
	ART OF PERFORMANCE / FLIP HOMOLOGATED 	PG. 426	3215172 € 120,00	3215172 € 120,00	-	-
	WILD LION HOMOLOGATED 	PG. 424	3216587 € 87,00	3216587 € 87,00	-	-
	RED SPONGE FOR ORIGINAL AIR BOX		1411407 € 3,85	1411407 € 3,85	-	-
	DOUBLE RED SPONGE FOR ORIGINAL AIR BOX		1414507 € 5,30	1414507 € 5,30	-	-
	GEARS HTQ PRIMARY		6714039 € 57,67 z 13/44	6714039 € 57,67 z 13/44	6714039 € 57,67 z 13/44	6714039 € 57,67 z 13/44
	GEARS HTQ SECONDARY	PG. 478	6714774 z 15/42 € 67,32 6714775 z 14/43 € 67,32	6714774 z 15/42 € 67,32 6714775 z 14/43 € 67,32	-	6714774 z 15/42 € 67,32 6714775 z 14/43 € 67,32
	ROLLER CRANKCASE		2515482 € 95,00	2515482 € 95,00	2515482 € 95,00	2515482 € 95,00
	SCREEN		-	-	-	-
	BRAKE PADS	FRONT	6215042 1997-> € 5,72 6215043 1993->96 € 5,80	6215042 1997-> € 5,72 6215043 1993->96 € 5,80	6215042 € 5,72 1997->	6215042 € 5,72 1997->
	BRAKE PADS MHR	FRONT	62 9083 1993->96 € 6,20 6215080 1997-> € 6,00	62 9083 1993->96 € 6,20 6215080 1997-> € 6,00	6215080 € 6,00 1997->	6215080 € 6,00 1997->
	BRAKE PADS MHR SYNT	FRONT	6215007 1997-> € 11,96 6215008 1993->96 € 11,96	6215007 1997-> € 11,96 6215008 1993->96 € 11,96	6215007 € 11,96 1997->	6215007 € 11,96 1997->
	BRAKE PADS	REAR	6215042 € 5,72 1997->	6215042 € 5,72 1997->	-	6215049 € 6,24 1997->
	BRAKE PADS MHR	REAR	6215080 € 6,00 1997->	6215080 € 6,00 1997->	-	6215074 € 6,30 1997->
	BRAKE PADS MHR SYNT	REAR	6215007 € 11,96 1997->	6215007 € 11,96 1997->	-	6215006 € 11,96 1997->
	BRAKE POWER	REAR	-	6215802 € 18,64 1993->96	6215802 € 18,64 1997->	-
	BRAKE SHOES	FRONT	-	-	-	-
	WHOOPIE DISC	FRONT	6212603 € 72,56 1993->	6212603 € 72,56 1993->	-	-
	WHOOPIE DISC	REAR	-	-	-	-
	RS1 - RS3	REAR SHOCK ABSORBER	46 7906 € 140,92	46 7906 € 140,92	4615433 € 90,78 46 8610 € 141,25	4615433 € 90,78 46 8610 € 141,25
	RS24 - RS24/10	FRONT SHOCK ABSORBER	-	-	-	-
	RS24 - RS24/10 - RS24/10-R	REAR SHOCK ABSORBER	46 7589 € 221,96 4614223 € 430,00	46 7589 € 221,96 4614223 € 430,00	46 8611 € 219,76	46 8611 € 219,76
	RS24	FRONT + REAR	-	-	-	-
	HORQUILLA F32S	FORK STEMS Ø 32	-	-	-	-
	HORQUILLA F37R MHR	FORK STEMS Ø 37	-	-	-	-

15 - WITH manual choke

19 - for the ASSEMBLY MODIFY the CRANKCASE

67 - TO COUPLE ONLY with MALOSSİ CYLINDERS: 3216986 € 122,00

BENELLI							BETA
K2	K2	K2	NAKED	PEPE	PEPE LX euro 2	QuattronoveX euro 2	ARK
					(QJ1E40QMB-4)		
50 2T	50 2T	100 2T	50 2T	50 2T	50 2T	50 2T	50 2T
72 9215 € 78,76 Ø 17,5	72 9215 € 78,76 Ø 17,5	-	72 9215 € 78,76 Ø 17,5	72 9215 € 78,76 Ø 17,5	72 9215 € 78,76 Ø 17,5	72 9215 € 78,76 Ø 17,5	72 9215 € 78,76 Ø 17,5
1611042 € 118,04	1611042 € 118,04	-	1611042 € 118,04	1611042 € 118,04	1611042 € 118,04	1611042 € 118,04	1611042 € 118,04
1610995 € 114,23	1610995 € 114,23	-	1610995 € 114,23	1610995 € 114,23	1610995 € 114,23	1610995 € 114,23	1610995 € 114,23
1611031 € 120,28	1611031 € 120,28	1611430 € 174,96	1611031 € 120,28	1611031 € 120,28	1611031 € 120,28	1611031 € 120,28	1611031 € 120,28
27 7731.C0 € 48,95 VL12	27 7731.C0 € 48,95 VL12	27 7731.C0 € 48,95 VL12	27 7731.C0 € 48,95 VL12	27 7731.C0 € 48,95 VL12	27 7731.C0 *19* € 48,95 VL12	27 7731.C0 *19* € 48,95 VL12	27 7731.C0 € 48,95 VL12
27 7054.C0 € 18,71	27 7054.C0 € 18,71	27 7054.C0 € 18,71	27 7054.C0 € 18,71	27 7054.C0 € 18,71	27 7054.C0 € 18,71	27 7054.C0 € 18,71	27 7054.C0 € 18,71
-	-	-	-	-	*67*	-	-
-	-	-	-	3216581 € 87,00	-	-	-
-	-	-	-	-	-	1414044 € 3,56	1411412 € 3,64
-	-	-	-	-	-	1414483 € 5,30	1414498 € 5,73
6714039 € 57,67 z 13/44	6714039 € 57,67 z 13/44	6711486 € 76,18 z 15/42	6714039 € 57,67 z 13/44	67 7580 € 61,88 z 14/42	6713602 € 67,32 z 14/42	6713602 € 67,32 z 14/42	6714039 € 57,67 z 13/44
-	-	-	-	-	-	-	-
2515482 € 95,00	2515482 € 95,00	-	2515482 € 95,00	-	-	-	2515482 € 95,00
-	-	-	-	-	-	-	-
6215042 € 5,72 1998->	6215042 € 5,72 1998->	6215042 € 5,72 1999->	6215042 € 5,72 1998	6215042 € 5,72 1999->	6215042 € 5,72	-	6215042 € 5,72 1996->
6215080 € 6,00 1998->	6215080 € 6,00 1998->	6215080 € 6,00 1999->	6215080 € 6,00 1998	6215080 € 6,00 1999->	6215080 € 6,00	-	6215080 € 6,00 1996->
6215007 € 11,96 1998->	6215007 € 11,96 1998->	6215007 € 11,96 1999->	6215007 € 11,96 1998->	6215007 € 11,96 1999->	6215007 € 11,96	-	6215007 € 11,96 1996->
-	6215042 € 5,72 1998->	-	-	-	-	-	-
-	6215080 € 6,00 1998->	-	-	-	-	-	-
-	6215007 € 11,96 1998->	-	-	-	-	-	-
-	-	-	-	6215802 € 18,64 1999->	6215802 € 18,64	-	6215802 € 18,64 1996->
-	-	-	-	-	-	-	6212603 € 72,56 1996->
-	-	-	-	-	-	-	-
4615433 € 90,78 46 8610 € 141,25	4615433 € 90,78 46 8610 € 141,25	-	4615433 € 90,78 46 8610 € 141,25	4615434 € 88,74 RS1	-	4615433 € 90,78 46 8610 € 141,25	46 7906 € 140,92 RS3
-	-	-	-	-	-	-	-
46 8611 € 219,76	46 8611 € 219,76	-	46 8611 € 219,76 RS24	46 7591 € 230,79 RS24	-	46 8611 € 219,76 RS24	46 7589 € 221,96 RS24
-	-	-	-	-	-	-	-
-	-	-	-	-	-	-	-
-	-	-	-	-	-	-	-



MALOSSI

Scooter 2T

with ENGINE 

BETA

ARK

CHRONO

EIKON

TEMPO

 **ATTENTION: ONLY FOR vehicles WITHOUT IMMOBILIZER KEY**

		50 2T	LC	50 2T		50 2T	LC	50 2T	
	CYLINDER+HEAD CAST-IRON Ø 40	31 8556	1	31 8562	1	31 8556	1	31 8562	1
	(pin) ALUMINIUM Ø 40-41	€161,98	Ø 40 (10)	€120,74	Ø 40 (10)	€161,98	Ø 40 (10)	€120,74	Ø 40 (10)
	CYLINDER+HEAD	31 8284	1	31 7083	1	31 8284	1	31 7083	1
	(pin) CAST-IRON Ø 47	€152,41	Ø 47 (10)	€114,25	Ø 47 (10)	€152,41	Ø 47 (10)	€114,25	Ø 47 (10)
	CYLINDER CAST-IRON Ø 47-57,5	-		31 7002		-		31 7002	
	for ORIGINAL HEAD ALUM. Ø 47>57,5			€97,90	Ø 47 (10)			€97,90	Ø 47 (10)
	HEAD HTSR	-		38 7246		-		38 7246	
	for Malossi CYLINDER			€37,47	Ø 47			€37,47	Ø 47
	CYLINDER+HEAD MHR Replica ALUMINIUM	31 8430	1	31 8437	1	31 8430	1	31 8437	1
	(pin) Ø 47	€228,06	Ø 47 (10)	€207,00	Ø 47 (10)	€228,06	Ø 47 (10)	€207,00	Ø 47 (10)
	CRANKSHAFTS RHQ	53 7891		53 7891		53 7891		53 7891	
	PIN Ø 10	€175,50		€175,50		€175,50		€175,50	
	CRANKSHAFTS RHQ	53 8009		53 8009		53 8009		53 8009	
	PIN Ø 12	€175,50		€175,50		€175,50		€175,50	
	RADIAL ROLLER BEARING FOR CRANKSHAFT		PG. 473		PG.473		PG.473		PG.473
	ELECTRONIC CONTROLLER	-		-		55 8133	*27*	-	
		€50,14				€50,14			
	ELECTRONIC CONTROLLER RPM CONTROL	55 8765		-		55 8676	*32*	-	
		€127,73				€97,59			
	MULTIVAR VARIATOR	51 7075		51 7075		51 7075		51 7075	
		€58,71		€58,71		€58,71		€58,71	
	X SPECIAL BELT BELT	6112730		6112730		6112730		6112730	
		€14,36		€14,36		€14,36		€14,36	
	X K BELT BELT	6112729		6112729		6112729		6112729	
	€25,23		€25,23		€25,23		€25,23		
	HTRoll ROLLERS FOR MULTIVAR	66 9823.M0		66 9823.M0		66 9823.M0		66 9823.M0	
		€9,50 gr.07		€9,50 gr.07		€9,50 gr.07		€9,50 gr.07	
	HTRoll ROLLERS FOR ORIGINAL VARIATOR	66 9417.F0		66 9417.H0		66 9417.I0		66 9417.I0	
		€7,24 gr.05,4		€7,24 gr.06,5		€7,24 gr.06,8		€7,24 gr.06,8	
	VENTILVAR FIXED HALF-PULLEY	61 7152		61 7152		61 7152		61 7152	
		€21,71		€21,71		€21,71		€21,71	
	VARIABLE-SPEED DRIVE ADJUSTER SPRING FOR VARIATOR		PG. 438		PG.438		PG.438		PG.438
	TORSION CONTROLLER ANTIFRICTION FIFTH WHEEL	2512827		2512827		2512827		2512827	
		€4,45		€4,45		€4,45		€4,45	
	TORQUE DRIVER MOBILE DRIVEN SPLIT PULLEY	61 8312 Ø 33 €85,57		61 8312 Ø 33 €85,57		61 9223		61 8312	
		61 9223 Ø 34 €85,57		61 9223 Ø 34 €85,57		€85,57		€85,57	
	FLY CLUTCH NOT ADJUSTABLE CLUTCH	52 8796 Ø 105 €53,26		52 8796 Ø 105 €53,26		52 9450		52 8796	
		52 9450 Ø 107 €47,30		52 9450 Ø 107 €47,30		€47,30		€53,26	
	DELTA CLUTCH ADJUSTABLE CLUTCH	52 7643 Ø 105 €77,89		52 7643 Ø 105 €77,89		52 9451		52 7643	
		52 9451 Ø 107 €77,89		52 9451 Ø 107 €77,89		€77,89		€77,89	
	CLUTCH BELL CLUTCH BELL (SMOOTH RING)	7711124		7711124		7711124		-	
		€22,60 Ø 107		€22,60 Ø 107		€22,60 Ø 107			
	WING CLUTCH BELL CLUTCH BELL (FINNED RING)	7711166		7711166		7711166		-	
		€33,45 Ø 107		€33,45 Ø 107		€33,45 Ø 107			
	FLY SYSTEM CLUTCH BELL + NOT ADJUSTABLE CLUTCH	5214112		5214112		5214112		-	
		€63,00 Ø 107		€63,00 Ø 107		€63,00 Ø 107			
	DELTA SYSTEM CLUTCH BELL + ADJUSTABLE CLUTCH	5214113		5214113		5214113		-	
		€93,84 Ø 107		€93,84 Ø 107		€93,84 Ø 107			
	SPORT SPRINGS FOR FLY / DELTA CLUTCH	29 8746		29 8746		29 8746		29 8746	
		€14,50		€14,50		€14,50		€14,50	
	MHR SPRINGS FOR FLY / DELTA CLUTCH	29 8747		29 8747		29 8747		29 8747	
		€19,40		€19,40		€19,40		€19,40	
	SPRINGS Ø INTERNAL CLUTCH BELL 105-107 FOR ORIGINAL CLUTCH	29 7714 Ø 105 €13,80		29 7714 Ø 105 €13,80		29 7714 Ø 105 €13,80		29 7714	
	29 9605 Ø 107 €16,20		29 9605 Ø 107 €16,20		29 9605 Ø 107 €16,20		€13,80 Ø 105		
	MUELLES Ø INTERNAL CLUTCH BELL 112 FOR ORIGINAL CLUTCH	29 7715		29 7715		29 7715		29 9605	
		€16,20 Ø 112		€16,20 Ø 112		€16,20 Ø 112		€16,20 Ø 107	

18 - To be assembled EXCLUSIVELY with MALOSSI EXHAUST SYSTEMS

27 - For vehicles with YAMAHA FLYWHEEL

32 - For vehicles with YAMAHA FLYWHEEL - If it is a DUCATI : TC UNIT K15 +BOBINA / RPM CONTROL 55 8765 € 127,73

CPI							DERBI
ARAGON GP	HUSSAR <-2002	HUSSAR 2003->	OLIVER <-2002	OLIVER 2003->	POPCORN <-2002	POPCORN 2003->	ATLANTIS <-2002
	(50 C)		(50 C)		(50 C)		
50 2T	50 2T	50 2T	50 2T	50 2T	50 2T	50 2T	50 2T
3113865 *18* € 120,74 Ø 40 (12)	31 8562 € 120,74 Ø 40 (10)	3113865 *18* € 120,74 Ø 40 (12)	31 8562 € 120,74 Ø 40 (10)	3113865 *18* € 120,74 Ø 40 (12)	31 8562 € 120,74 Ø 40 (10)	3113865 *18* € 120,74 Ø 40 (12)	-
3113066 *18* € 117,81 Ø 47 (12)	31 7083 € 114,25 Ø 47 (10)	3113066 *18* € 117,81 Ø 47 (12)	31 7083 € 114,25 Ø 47 (10)	3113066 *18* € 117,81 Ø 47 (12)	31 7083 € 114,25 Ø 47 (10)	3113066 *18* € 117,81 Ø 47 (12)	3111143 € 125,95 Ø 47 (10)
3113067 € 97,90 Ø 47 (12)	31 7002 € 97,90 Ø 47 (10)	3113067 € 97,90 Ø 47 (12)	31 7002 € 97,90 Ø 47 (10)	3113067 € 97,90 Ø 47 (12)	31 7002 € 97,90 Ø 47 (10)	3113067 € 97,90 Ø 47 (12)	-
38 7246 € 37,47 Ø 47	38 7246 € 37,47 Ø 47	38 7246 € 37,47 Ø 47	38 7246 € 37,47 Ø 47	38 7246 € 37,47 Ø 47	38 7246 € 37,47 Ø 47	38 7246 € 37,47 Ø 47	38 9041 € 37,47 Ø 47
-	31 8437 € 207,00 Ø 47 (10)	-	31 8437 € 207,00 Ø 47 (10)	-	31 8437 € 207,00 Ø 47 (10)	-	-
-	-	-	-	-	-	-	-
5313587 € 175,50	-	5313587 € 175,50	-	5313587 € 175,50	-	5313587 € 175,50	-
-	-	-	-	-	-	-	-
-	55 8133 € 50,14	-	55 8133 € 50,14	-	55 8133 € 50,14	-	-
-	-	-	-	-	-	-	-
5113363 € 60,00	5113363 € 60,00	5113363 € 60,00	5113363 € 60,00	5113363 € 60,00	5113363 € 60,00	5113363 € 60,00	5111151 € 58,71
61 9832 € 17,04	-	61 9832 € 17,04	-	61 9832 € 17,04	-	61 9832 € 17,04	6111164 € 18,68
61 7587 € 28,25	-	61 7587 € 28,25	-	61 7587 € 28,25	-	61 7587 € 28,25	6111152 € 28,25
66 9823.L0 gr.06 € 9,50 66 9823.O0 gr.09 € 9,50	66 9823.L0 gr.06 € 9,50 66 9823.O0 gr.09 € 9,50	66 9823.L0 gr.06 € 9,50 66 9823.O0 gr.09 € 9,50	66 9823.L0 gr.06 € 9,50 66 9823.O0 gr.09 € 9,50	66 9823.L0 gr.06 € 9,50 66 9823.O0 gr.09 € 9,50	66 9823.L0 gr.06 € 9,50 66 9823.O0 gr.09 € 9,50	66 9823.L0 gr.06 € 9,50 66 9823.O0 gr.09 € 9,50	66 9823.M0 € 9,50 gr.07
66 9417.G0 € 7,24 gr.06	66 9417.G0 € 7,24 gr.06	66 9417.G0 € 7,24 gr.06	66 9417.G0 € 7,24 gr.06	66 9417.G0 € 7,24 gr.06	66 9417.G0 € 7,24 gr.06	66 9417.G0 € 7,24 gr.06	66 9999.G0 € 8,50 gr.07
61 7151 € 21,28	-	61 7151 € 21,28	-	61 7151 € 21,28	-	61 7151 € 21,28	-
PG.438	PG.438	PG.438	PG.438	PG.438	PG.438	PG.438	PG.438
-	-	-	-	-	-	-	-
61 8312 € 85,57	61 8312 € 85,57	61 8312 € 85,57	61 8312 € 85,57	61 8312 € 85,57	61 8312 € 85,57	61 8312 € 85,57	-
52 8798 € 47,30	52 8798 € 47,30	52 8798 € 47,30	52 8798 € 47,30	52 8798 € 47,30	52 8798 € 47,30	52 8798 € 47,30	52 8798 € 47,30
52 7879 € 77,89	52 7879 € 77,89	52 7879 € 77,89	52 7879 € 77,89	52 7879 € 77,89	52 7879 € 77,89	52 7879 € 77,89	52 7879 € 77,89
-	-	-	-	-	-	-	-
-	-	-	-	-	-	-	-
-	-	-	-	-	-	-	-
29 8746 € 14,50	29 8746 € 14,50	29 8746 € 14,50	29 8746 € 14,50	29 8746 € 14,50	29 8746 € 14,50	29 8746 € 14,50	29 8746 € 14,50
29 8747 € 19,40	29 8747 € 19,40	29 8747 € 19,40	29 8747 € 19,40	29 8747 € 19,40	29 8747 € 19,40	29 8747 € 19,40	29 8747 € 19,40
2913851 € 15,50	29 7714 € 13,80	2913851 € 15,50	29 7714 € 13,80	2913851 € 15,50	29 7714 € 13,80	2913851 € 15,50	29 7456 € 16,20
-	-	-	-	-	-	-	-



MALOSSI

Scooter 2T

with ENGINE **BETA**

ARK

CHRONO

EIKON

TEMPO

50 2T

LC

50 2T











50 2T

LC

50 2T

**() CHECK "TYPE" SPECIFICATION (HOMOLOGATION MARK)**

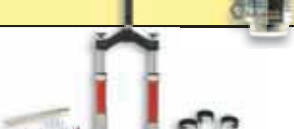
	CARBURETTOR		72 9215 € 78,76 Ø 17,5	72 9215 € 78,76 Ø 17,5	72 9215 € 78,76 Ø 17,5	72 9215 € 78,76 Ø 17,5
	CARBURETTOR KIT	Ø 19	1611042 € 118,04	1611042 € 118,04	1611042 € 118,04	1611042 € 118,04
	CARBURETTOR KIT	Ø 21	1610995 € 114,23	1610995 € 114,23	1610995 € 114,23	1610995 € 114,23
	CARBURETTOR KIT	Ø 22	1611031 € 120,28	1611031 € 120,28	1611031 € 120,28	1611031 € 120,28
	REED VALVE CARBON FIBRE		27 7731.C0 € 48,95 VL12	27 7731.C0 € 48,95 VL12	27 7731.C0 € 48,95 VL12	27 7731.C0 € 48,95 VL12
	PETALS SET FOR ORIGINAL REED VALVE		27 7054.C0 € 18,71	27 7054.C0 € 18,71	27 7054.C0 € 18,71	27 7054.C0 € 18,71
	ART OF PERFORMANCE / FLIP HOMOLOGATED 	PG. 426	-	-	-	-
	WILD LION HOMOLOGATED 	PG. 424	-	-	-	-
	RED SPONGE FOR ORIGINAL AIR BOX		1411412 € 3,64	-	-	-
	DOUBLE RED SPONGE FOR ORIGINAL AIR BOX		1414498 € 5,73	-	-	-
	GEARS HTQ PRIMARY		6714039 € 57,67 z 13/44	67 7580 € 61,88 z 14/42	6714039 € 57,67 z 13/44	67 7580 € 61,88 z 14/42
	GEARS HTQ SECONDARY	PG. 478	-	-	-	-
	ROLLER CRANKCASE		2515482 € 95,00	-	2515482 € 95,00	-
	SCREEN		-	-	-	-
	BRAKE PADS FRONT		6215042 € 5,72 1996->	6215050 € 6,24 1992->94	6215051 € 5,72 1999->	6215050 € 6,24 1993->
	BRAKE PADS MHR FRONT		6215080 € 6,00 1996->	62 9841 € 6,10 1992->94	6215076 € 6,24 1999->	62 9841 € 6,10 1993->
	BRAKE PADS MHR SYNT FRONT		6215007 € 11,96 1996->	-	6215005 € 11,96 1999->	-
	BRAKE PADS REAR		6215042 € 5,72 1996->	-	6215051 € 5,72 1999->	-
	BRAKE PADS MHR REAR		6215080 € 6,00 1996->	-	6215076 € 6,24 1999->	-
	BRAKE PADS MHR SYNT REAR		6215007 € 11,96 1996->	-	6215005 € 11,96 1999->	-
	BRAKE POWER REAR		-	6215802 € 18,64 1992->94	-	6215802 € 18,64 1993->
	BRAKE SHOES FRONT		-	-	-	-
	WHOOP DISC FRONT		6212603 € 72,56 1996->	6212603 € 72,56 1992->94	6212603 € 72,56 1999->	-
	WHOOP DISC REAR		-	-	-	-
	RS1 - RS3 REAR SHOCK ABSORBER		46 7906 € 140,92 RS3	4615434 € 88,74 RS1	46 7906 € 140,92 RS3	4615434 € 88,74 RS1
	RS24 - RS24/10 FRONT SHOCK ABSORBER		-	-	-	-
	RS24 - RS24/10 - RS24/10-R REAR SHOCK ABSORBER		46 7589 € 221,96 RS24	46 7591 € 230,79 RS24	46 7589 € 221,96 RS24	46 7591 € 230,79 RS24
	RS24 FRONT + REAR		-	-	-	-
	HORQUILLA F32S FORK STEMS Ø 32		-	-	-	-
	HORQUILLA F37R MHR FORK STEMS Ø 37		-	-	-	-

19 - for the ASSEMBLY MODIFY the CRANKCASE

67 - TO COUPLE ONLY with MALOSSİ CYLINDERS: 3216986 € 122,00

CPI							DERBI
ARAGON GP	HUSSAR <-2002	HUSSAR 2003->	OLIVER <-2002	OLIVER 2003->	POPCORN <-2002	POPCORN 2003->	ATLANTIS <-2002
	(50 C)		(50 C)		(50 C)		
50 2T	50 2T	50 2T	50 2T	50 2T	50 2T	50 2T	50 2T
72 9215 € 78,76 Ø 17,5	72 9215 € 78,76 Ø 17,5	72 9215 € 78,76 Ø 17,5	72 9215 € 78,76 Ø 17,5	72 9215 € 78,76 Ø 17,5	72 9215 € 78,76 Ø 17,5	72 9215 € 78,76 Ø 17,5	-
1611042 € 118,04	1611042 € 118,04	1611042 € 118,04	1611042 € 118,04	1611042 € 118,04	1611042 € 118,04	1611042 € 118,04	1611040 € 118,04
1610995 € 114,23	1610995 € 114,23	1610995 € 114,23	1610995 € 114,23	1610995 € 114,23	1610995 € 114,23	1610995 € 114,23	1610997 € 114,23
1611031 € 120,28	1611031 € 120,28	1611031 € 120,28	1611031 € 120,28	1611031 € 120,28	1611031 € 120,28	1611031 € 120,28	-
27 7731.C0 *19* € 48,95 VL12	27 7731.C0 € 48,95 VL12	27 7731.C0 *19* € 48,95 VL12	27 7731.C0 € 48,95 VL12	27 7731.C0 *19* € 48,95 VL12	27 7731.C0 € 48,95 VL12	27 7731.C0 *19* € 48,95 VL12	-
27 7054.C0 € 18,71	27 7054.C0 € 18,71	27 7054.C0 € 18,71	27 7054.C0 € 18,71	27 7054.C0 € 18,71	27 7054.C0 € 18,71	27 7054.C0 € 18,71	27 2728.C0 € 16,27
67	-	*67*	-	*67*	-	*67*	-
-	-	-	-	3216592 € 87,00	-	-	-
1414044 € 3,56	1411407 € 3,85	1414044 € 3,56	1411407 € 3,85	1414044 € 3,56	1411407 € 3,85	1414044 € 3,56	-
1414483 € 5,30	1414507 € 5,30	1414483 € 5,30	1414507 € 5,30	1414483 € 5,30	1414507 € 5,30	1414483 € 5,30	-
6713602 € 67,32 z 14/42	-	6713602 € 67,32 z 14/42	-	6713602 € 67,32 z 14/42	-	6713602 € 67,32 z 14/42	6711160 € 57,18 z 15/43
-	-	-	-	-	-	-	-
-	-	-	-	-	-	-	-
-	-	-	-	-	-	-	-
-	-	-	-	-	-	-	-
-	-	-	-	-	-	-	-
-	-	-	-	-	-	-	-
-	-	-	-	-	-	-	-
-	-	-	-	-	-	-	-
-	-	-	-	-	-	-	-
6212603 € 72,56	6212603 € 72,56	6212603 € 72,56	6212603 € 72,56	6212603 € 72,56	6212603 € 72,56	6212603 € 72,56	-
-	-	-	-	-	-	-	-
4615433 € 90,78 46 8610 € 141,25	4615433 € 90,78 46 8610 € 141,25	4615433 € 90,78 46 8610 € 141,25	4615433 € 90,78 46 8610 € 141,25	4615433 € 90,78 46 8610 € 141,25	4615433 € 90,78 46 8610 € 141,25	4615433 € 90,78 46 8610 € 141,25	-
-	-	-	-	-	-	-	-
46 8611 € 219,76 RS24	46 8611 € 219,76 RS24	46 8611 € 219,76 RS24	46 8611 € 219,76 RS24	46 8611 € 219,76 RS24	46 8611 € 219,76 RS24	46 8611 € 219,76 RS24	-
-	-	-	-	-	-	-	-
-	-	-	-	-	-	-	-
-	-	-	-	-	-	-	-



MALOSSI

Scooter 2T

with ENGINE **DERBI**ATLANTIS -
BULLET
2003->

ATLANTIS

GP1

GP1 OPEN

(▲) ATTENTION: ONLY FOR vehicles WITHOUT IMMOBILIZER KEY

		50 2T	 50 2T	LC	50 2T	LC	50 2T	LC
	CYLINDER+HEAD CAST-IRON Ø 40	31 8520	-	-	31 8523	-	31 8523	-
	(pin) ALUMINIUM Ø 40-41	€124,91 Ø 40 (12)	-	-	€164,21 Ø 40 (12)	-	€164,21 Ø 40 (12)	-
	CYLINDER+HEAD	31 6926	3111146	-	31 7353	-	31 7353	-
	(pin) CAST-IRON Ø 47	€120,25 Ø 47 (12)	€186,72 Ø 47 (10)	-	€176,03 Ø 47 (12)	-	€176,03 Ø 47 (12)	-
	CYLINDER CAST-IRON Ø 47-57,5	31 6915	-	-	-	-	-	-
for ORIGINAL HEAD ALUM. Ø 47>57,5	€100,86 Ø 47 (12)	-	-	-	-	-	-	
HEAD HTSR	38 7118	-	-	-	-	-	-	
for Malossi CYLINDER	€37,45 Ø 47	-	-	-	-	-	-	
CYLINDER+HEAD MHR Replica ALUMINIUM	31 8463	-	-	31 8466	-	31 8466	-	
(pin) Ø 47	€207,00 Ø 47 (12)	-	-	€239,46 Ø 47 (12)	-	€239,46 Ø 47 (12)	-	
	CRANKSHAFTS RHQ	-	-	-	-	-	-	
	PIN Ø 10	-	-	-	-	-	-	
	CRANKSHAFTS RHQ	53 7600	-	53 7600	-	53 7600	-	
	PIN Ø 12	€175,50	-	€175,50	-	€175,50	-	
	RADIAL ROLLER BEARING	6614105E	-	6614105E	-	6614105E	-	
	FOR CRANKSHAFT	PG. 473 €43,00	-	€43,00	-	€43,00	-	
	ELECTRONIC CONTROLLER	-	-	5513195	*35*	5513195	*35*	
		-	-	€92,82	-	€92,82	-	
	ELECTRONIC CONTROLLER	-	-	5513196	*35*	5513196	*35*	
	RPM CONTROL	-	-	€140,51	-	€140,51	-	
	MULTIVAR	51 9019	5111151	51 9019	-	51 9019	-	
	VARIATOR	€61,80	€58,71	€61,80	-	€61,80	-	
	X SPECIAL BELT	61 9831	6111164	61 9831	-	61 9831	-	
	BELT	€19,49	€18,68	€19,49	-	€19,49	-	
	X K BELT	6114118	6111152	6114118	-	6114118	-	
BELT	€38,25	€28,25	€38,25	-	€38,25	-		
HTRoll	66 9420.M0	66 9823.M0	66 9420.M0	-	66 9420.M0	-		
ROLLERS FOR MULTIVAR	€10,00 gr.07,2	€9,50 gr.07	€10,00 gr.07,2	-	€10,00 gr.07,2	-		
HTRoll	66 9420.NO	66 9999.G0	66 9420.NO	-	66 9420.NO	-		
ROLLERS FOR ORIGINAL VARIATOR	€10,00 gr.07,5	€8,50 gr.07	€10,00 gr.07,5	-	€10,00 gr.06,5	-		
	VENTILVAR	-	-	-	-	-	-	
FIXED HALF-PULLEY	-	-	-	-	-	-	-	
	VARIABLE-SPEED DRIVE ADJUSTER SPRING	PG. 438 PG.438	PG.438	PG.438	PG.438	PG.438	PG.438	
	FOR VARIATOR	-	-	-	-	-	-	
	TORSION CONTROLLER	2512828	-	2512828	-	2512828	-	
	ANTIFRICTION FIFTH WHEEL	€4,45	-	€4,45	-	€4,45	-	
	TORQUE DRIVER	61 9100	-	61 9100	-	61 9100	-	
	MOBILE DRIVEN SPLIT PULLEY	€85,57	-	€85,57	-	€85,57	-	
	FLY CLUTCH	52 8797	52 8798	52 8797	-	52 8797	-	
	NOT ADJUSTABLE CLUTCH	€47,30	€47,30	€47,30	-	€47,30	-	
	DELTA CLUTCH	52 7880	52 7879	52 7880	-	52 7880	-	
	ADJUSTABLE CLUTCH	€77,89	€77,89	€77,89	-	€77,89	-	
	CLUTCH BELL	7711115	-	7711115	-	7711115	-	
	CLUTCH BELL (SMOOTH RING)	€22,60 Ø 107	-	€22,60 Ø 107	-	€22,60 Ø 107	-	
	WING CLUTCH BELL	7711207	-	7711207	-	7711207	-	
	CLUTCH BELL (FINNED RING)	€33,45 Ø 107	-	€33,45 Ø 107	-	€33,45 Ø 107	-	
	FLY SYSTEM	5214111	-	5214111	-	5214111	-	
	CLUTCH BELL + NOT ADJUSTABLE CLUTCH	€63,00 Ø 107	-	€63,00 Ø 107	-	€63,00 Ø 107	-	
	DELTA SYSTEM	5214110	-	5214110	-	5214110	-	
	CLUTCH BELL + ADJUSTABLE CLUTCH	€93,84 Ø 107	-	€93,84 Ø 107	-	€93,84 Ø 107	-	
	SPORT SPRINGS	29 8746	29 8746	29 8746	-	29 8746	-	
	FOR FLY / DELTA CLUTCH	€14,50	€14,50	€14,50	-	€14,50	-	
	MHR SPRINGS	29 8747	29 8747	29 8747	-	29 8747	-	
	FOR FLY / DELTA CLUTCH	€19,40	€19,40	€19,40	-	€19,40	-	
	SPRINGS Ø INTERNAL CLUTCH BELL 105-107	29 7454	29 7456	29 7454	-	29 7454	-	
FOR ORIGINAL CLUTCH	€16,20	€16,20	€16,20	-	€16,20	-		
MUELLES Ø INTERNAL CLUTCH BELL 112	-	-	-	-	-	-	-	
FOR ORIGINAL CLUTCH	-	-	-	-	-	-	-	

18 - To be assembled EXCLUSIVELY with MALOSSI EXHAUST SYSTEMS

35 - IT CAN BE ASSEMBLED WITH NO MODIFICATION to the original system, EVEN ON vehicles PRODUCED 2001->

DERBI						EXPLORER	GARELLI
GP1 REVOLUTION	HUNTER	PADDOCK	PADDOCK	PREDATOR	PREDATOR	CRACKER 2003->	GSP euro 2
						(GE 1E 400 MB)	(1PE40MB)
50 2T LC	50 2T	50 2T	50 2T LC	50 2T	50 2T LC	50 2T	50 2T LC
31 8523 €164,21 Ø 40 (12)	-	-	-	-	-	3113865 *18* €120,74 Ø 40 (12)	31 8556 €161,98 Ø 40 (10)
31 7353 €176,03 Ø 47 (12)	3111143 €125,95 Ø 47 (10)	3111143 €125,95 Ø 47 (10)	3111146 €186,72 Ø 47 (10)	3111143 €125,95 Ø 47 (10)	3111146 €186,72 Ø 47 (10)	3113066 *18* €117,81 Ø 47 (12)	31 8284 €152,41 Ø 47 (10)
-	-	-	-	-	-	3113067 €97,90 Ø 47 (12)	-
-	38 9041 €37,47 Ø 47	38 9041 €37,47 Ø 47	-	38 9041 €37,47 Ø 47	-	38 7246 €37,47 Ø 47	-
31 8466 €239,46 Ø 47 (12)	-	-	-	-	-	-	31 8430 €228,06 Ø 47 (10)
-	-	-	-	-	-	-	-
53 7600 €175,50	-	-	-	-	-	5313587 €175,50	-
6614105E €43,00	-	-	-	-	-	-	PG.473
5513195 *35* €92,82	-	-	-	-	-	-	-
5513196 *35* €140,51	-	-	-	-	-	-	-
51 9019 €61,80	5111151 €58,71	5111151 €58,71	5111151 €58,71	5111151 €58,71	5111151 €58,71	5113363 €60,00	51 7075 €58,71
61 9831 €19,49	6111164 €18,68	6111164 €18,68	6111164 €18,68	6111164 €18,68	6111164 €18,68	61 9832 €17,04	61 9832 €17,04
6114118 €38,25	6111152 €28,25	6111152 €28,25	6111152 €28,25	6111152 €28,25	6111152 €28,25	61 7587 €28,25	-
66 9420.M0 €10,00 gr.07,2	66 9823.M0 €9,50 gr.07	66 9823.M0 €9,50 gr.07	66 9823.M0 €9,50 gr.07	66 9823.M0 €9,50 gr.07	66 9823.M0 €9,50 gr.07	66 9823.L0 gr.06 €9,50 66 9823.O0 gr.09 €9,50	66 9823.M0 €9,50 gr.07
66 9420.I0 €10,00 gr.06,5	66 9999.F0 €8,50 gr.06,5	66 9999.F0 €8,50 gr.06,5	66 9999.E0 €8,50 gr.06	66 9999.G0 €8,50 gr.07	66 9999.G0 €8,50 gr.07	66 9417.G0 €7,24 gr.06	66 9417.E0 €7,24 gr.04,8
-	-	-	-	-	-	61 7151 €21,28	61 7152 €21,71
PG.438	PG.438	PG.438	PG.438	PG.438	PG.438	PG.438	PG.438
2512828 €4,45	-	-	-	-	-	-	2512827 €4,45
61 9100 €85,57	-	-	-	-	-	61 8312 €85,57 Ø 33	61 8312 €85,57
52 8797 €47,30	52 8798 €47,30	52 8798 €47,30	52 8798 €47,30	52 8798 €47,30	52 8798 €47,30	52 8798 €47,30	52 8798 €47,30
52 7880 €77,89	52 7879 €77,89	52 7879 €77,89	52 7879 €77,89	52 7879 €77,89	52 7879 €77,89	52 7879 €77,89	52 7879 €77,89
7711115 €22,60 Ø 107	-	-	-	-	-	-	-
7711207 €33,45 Ø 107	-	-	-	-	-	-	-
5214111 €63,00 Ø 107	-	-	-	-	-	-	-
5214110 €93,84 Ø 107	-	-	-	-	-	-	-
29 8746 €14,50	29 8746 €14,50	29 8746 €14,50	29 8746 €14,50	29 8746 €14,50	29 8746 €14,50	29 8746 €14,50	29 8746 €14,50
29 8747 €19,40	29 8747 €19,40	29 8747 €19,40	29 8747 €19,40	29 8747 €19,40	29 8747 €19,40	29 8747 €19,40	29 8747 €19,40
29 7454 €16,20	29 7456 €16,20	29 7456 €16,20	29 7456 €16,20	29 7456 €16,20	29 7456 €16,20	2913851 €15,50	29 7714 €13,80 Ø 105
-	-	-	-	-	-	-	29 9605 €16,20 Ø 107



MALOSSI

Scooter 2T

with ENGINE **DERBI**ATLANTIS -
BULLET
2003->

ATLANTIS

GP1

GP1 OPEN

50 2T



50 2T

LC













50 2T

LC

50 2T

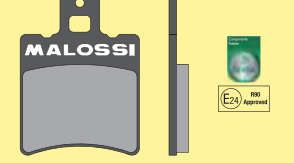
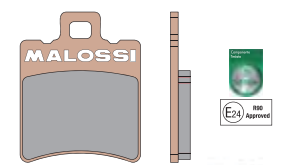
LC

(■) CHECK "TYPE" SPECIFICATION (HOMOLOGATION MARK)

	CARBURETTOR		72 7084 € 75,17 Ø 17,5	-	72 7084 € 75,17 Ø 17,5	72 7084 € 75,17 Ø 17,5
	CARBURETTOR KIT	Ø 19	1611040 € 118,04	1611040 € 118,04	1611040 € 118,04	1611040 € 118,04
	CARBURETTOR KIT	Ø 21	1610997 € 114,23	1610997 € 114,23	1610997 € 114,23	1610997 € 114,23
	CARBURETTOR KIT	Ø 22	1611029 € 96,77	-	1611029 € 96,77	1611029 € 96,77
	REED VALVE CARBON FIBRE		27 7708.CO € 48,95 VL11	-	27 7708.CO € 48,95 VL11	27 7708.CO € 48,95 VL11
	PETALS SET FOR ORIGINAL REED VALVE		27 7054.CO € 18,71	27 2728.CO € 16,27	27 7054.CO € 18,71	27 7054.CO € 18,71
	ART OF PERFORMANCE / FLIP HOMOLOGATED  	PG. 426	-	-	-	-
	WILD LION HOMOLOGATED 	PG. 424	-	-	-	-
	RED SPONGE FOR ORIGINAL AIR BOX		1411778 € 3,54	-	1411778 € 3,54	1411778 € 3,54
	DOUBLE RED SPONGE FOR ORIGINAL AIR BOX		1414497 € 6,16	-	1414497 € 6,16	1414497 € 6,16
	GEARS HTQ PRIMARY		67 9080 z 14/39 € 60,41 6713339 z 15/38 € 61,71	6711160 € 57,18 z 15/43	67 9080 z 14/39 € 60,41 6713339 z 15/38 € 61,71	67 9080 z 14/39 € 60,41 6713339 z 15/38 € 61,71
	GEARS HTQ SECONDARY	PG. 478	67 9966 € 65,00 z 13/48	-	67 9966 € 65,00 z 13/48	67 9966 € 65,00 z 13/48 (17)
	ROLLER CRANKCASE		2514521 *66* € 95,00	-	2514521 *66* € 95,00	2514521 *66* € 95,00
	SCREEN		-	-	-	-
	BRAKE PADS	FRONT	-	-	-	-
	BRAKE PADS MHR ORGANIC BRAKE PADS	FRONT	-	-	-	-
	BRAKE PADS MHR SYNT SINTERED BRAKE PADS	FRONT	-	-	-	-
	BRAKE PADS	REAR	-	-	-	-
	BRAKE PADS MHR ORGANIC BRAKE PADS	REAR	-	-	-	-
	BRAKE PADS MHR SYNT SINTERED BRAKE PADS	REAR	-	-	-	-
	BRAKE POWER	REAR	-	-	-	-
	BRAKE SHOES	FRONT	-	-	-	-
	WHOOP DISC BRAKE DISC	FRONT	-	-	-	-
	WHOOP DISC BRAKE DISC	REAR	-	-	-	-
	RS1 - RS3 REAR SHOCK ABSORBER		-	-	-	-
	RS24 - RS24/10 FRONT SHOCK ABSORBER		-	-	-	-
	RS24 - RS24/10 - RS24/10-R REAR SHOCK ABSORBER		-	-	-	-
	RS24 FRONT + REAR		-	-	-	-
	HORQUILLA F32S FORK STEMS Ø 32		-	-	-	-
	HORQUILLA F37R MHR FORK STEMS Ø 37		-	-	-	-

19 - for the ASSEMBLY MODIFY the CRANKCASE

66 - NOT to be used on VEHICLE WITH ORIGINAL PRIMARY GEARS

67 - TO COUPLE ONLY with MALOSSI CYLINDERS: 3216986 € 122,00

DERBI						EXPLORER	GARELLI
GP1 REVOLUTION	HUNTER	PADDOCK	PADDOCK	PREDATOR	PREDATOR	CRACKER 2003->	GSP euro 2
						(GE 1E 400 MB)	(1PE40MB)
50 2T LC	50 2T	50 2T	50 2T LC	50 2T	50 2T LC	50 2T	50 2T LC
72 7084 € 75,17 Ø 17,5	-	-	-	-	-	72 9215 € 78,76 Ø 17,5	72 9215 € 78,76 Ø 17,5
1611040 € 118,04	1611040 € 118,04	1611040 € 118,04	1611040 € 118,04	1611040 € 118,04	1611040 € 118,04	1611042 € 118,04	1611042 € 118,04
1610997 € 114,23	1610997 € 114,23	1610997 € 114,23	1610997 € 114,23	1610997 € 114,23	1610997 € 114,23	1610995 € 114,23	1610995 € 114,23
1611029 € 96,77	-	-	-	-	-	1611031 € 120,28	1611031 € 120,28
27 7708.CO € 48,95 VL11	-	-	-	-	-	27 7731.CO *19* € 48,95 VL12	27 7731.CO € 48,95 VL12
27 7054.CO € 18,71	27 2728.CO € 16,27	27 2728.CO € 16,27	27 2728.CO € 16,27	27 2728.CO € 16,27	27 2728.CO € 16,27	27 7054.CO € 18,71	27 7054.CO € 18,71
-	-	-	-	-	-	*67*	3216986 € 122,00
-	-	-	-	-	-	-	-
-	-	-	-	-	-	1414044 € 3,56	1414044 € 3,56
-	-	-	-	-	-	1414483 € 5,30	1414483 € 5,30
67 9080 z 14/39 € 60,41 6713339 z 15/38 € 61,71	6711542 € 56,36 z 15/43	6711542 € 56,36 z 15/43	6711160 € 57,18 z 15/43	6711160 € 57,18 z 15/43	6711160 € 57,18 z 15/43	6713602 € 67,32 z 14/42	-
-	-	-	-	-	-	-	-
2514521 *66* € 95,00	-	-	-	-	-	-	-
-	-	-	-	-	-	-	-
6216896 € 9,50	-	6215051 € 5,72 1997->	6215051 € 5,72 1997->	-	-	-	-
-	-	6215076 € 6,24 1997->	6215076 € 6,24 1997->	-	-	-	-
6215017 € 15,00	-	6215005 € 11,96 1997->	6215005 € 11,96 1997->	-	-	-	-
6215051 € 5,72	-	-	-	-	-	-	6215051 € 5,72
6215076 € 6,24	-	-	-	-	-	-	6215076 € 6,24
6215005 € 11,96	-	-	-	-	-	-	6215005 € 11,96
-	-	-	-	-	-	-	-
-	-	-	-	-	-	6212603 € 72,56	6212603 € 72,56
-	-	-	-	-	-	-	6212603 € 72,56
-	-	-	-	-	-	4615433 € 90,78 46 8610 € 141,25	4615433 € 90,78 46 8610 € 141,25
-	-	-	-	-	-	-	-
-	-	-	-	-	-	46 8611 € 219,76 RS24	46 8611 € 219,76 RS24
-	-	-	-	-	-	-	-
-	-	-	-	-	-	-	-



MALOSSI

Scooter 2T

with ENGINE **GARELLI****GILERA**TIESSE 50R
euro 2

DNA

EASY MOVING

ICE

(1E40QMB)

50 2T



50 2T

LC

50 2T



50 2T

**(▲) ATTENTION: ONLY FOR vehicles WITHOUT IMMOBILIZER KEY**

	CYLINDER+HEAD CAST-IRON Ø 40	3113865 *18*	31 8523	31 8520	31 8520
	(pin) ALUMINIUM Ø 40-41	€120,74 Ø 40 (12)	€164,21 Ø 40 (12)	€124,91 Ø 40 (12)	€124,91 Ø 40 (12)
	CYLINDER+HEAD	3113066 *18*	31 7353	31 6926	31 6926
	(pin) CAST-IRON Ø 47	€117,81 Ø 47 (12)	€176,03 Ø 47 (12)	€120,25 Ø 47 (12)	€120,25 Ø 47 (12)
	CYLINDER CAST-IRON Ø 47-57,5	3113067	-	31 6915	31 6915
	for ORIGINAL HEAD ALUM. Ø 47>57,5	€97,90 Ø 47 (12)	-	€100,86 Ø 47 (12)	€100,86 Ø 47 (12)
	HEAD HTSR	38 7246	-	38 7118	38 7118
	for Malossi CYLINDER	€37,47 Ø 47	-	€37,45 Ø 47	€37,45 Ø 47
	CYLINDER+HEAD MHR Replica ALUMINIUM	-	31 8466	31 8463	31 8463
	(pin) Ø 47	-	€239,46 Ø 47 (12)	€207,00 Ø 47 (12)	€207,00 Ø 47 (12)
	CRANKSHAFTS RHQ	-	-	-	-
	PIN Ø 10	-	-	-	-
	CRANKSHAFTS RHQ	5313587	53 7600	53 7600	53 7600
	PIN Ø 12	€175,50	€175,50	€175,50	€175,50
	RADIAL ROLLER BEARING	-	6614105E	6614105E	6614105E
	FOR CRANKSHAFT	PG. 473	€43,00	€43,00	€43,00
	ELECTRONIC CONTROLLER	-	5513195 *35*	5513195 *35*	5513195 *35*
			€92,82	€92,82	€92,82
	ELECTRONIC CONTROLLER	-	5513196 *35*	5513196 *35*	5513196 *35*
	RPM CONTROL		€140,51	€140,51	€140,51
	MULTIVAR	5113363	51 9019 €61,80	51 7382	51 9019
	VARIATOR	€60,00	51 9448 1997 €60,00	€58,71	€61,80
	X SPECIAL BELT	61 9832	61 9830	61 9829	61 9831
	BELT	€17,04	€17,34	€20,63	€19,49
	X K BELT	61 7587	61 9535	61 7665	6114118
	BELT	€28,25	€28,72	€25,68	€38,25
	HTRoll	66 9823.L0 gr.06 €9,50	66 9420.M0	66 9823.N0	66 9420.M0
	ROLLERS FOR MULTIVAR	66 9823.O0 gr.09 €9,50	€10,00 gr.07,2	€9,50 gr.08	€10,00 gr.07,2
	HTRoll	66 9417.E0	66 9420.N0	66 9823.R0	66 9420.N0
	ROLLERS FOR ORIGINAL VARIATOR	€7,24 gr.04,8	€10,00 gr.07,5	€9,50 gr.08,5	€10,00 gr.07,5
	VENTILVAR	61 7151	-	-	-
	FIXED HALF-PULLEY	€21,28	-	-	-
	VARIABLE-SPEED DRIVE ADJUSTER SPRING	PG. 438	PG.438	PG.438	PG.438
	FOR VARIATOR				
	TORSION CONTROLLER	-	2512828	2512828	2512828
	ANTIFRICTION FIFTH WHEEL		€4,45	€4,45	€4,45
	TORQUE DRIVER	61 8312	61 9100	61 8233	61 9100
	MOBILE DRIVEN SPLIT PULLEY	€85,57	€85,57	€85,57	€85,57
	FLY CLUTCH	52 8798	52 8797	52 8797	52 8797
	NOT ADJUSTABLE CLUTCH	€47,30	€47,30	€47,30	€47,30
	DELTA CLUTCH	52 7879	52 7880	52 7880	52 7880
	ADJUSTABLE CLUTCH	€77,89	€77,89	€77,89	€77,89
	CLUTCH BELL	-	7711115	7711115	7711115
	CLUTCH BELL (SMOOTH RING)		€22,60 Ø 107	€22,60 Ø 107	€22,60 Ø 107
	WING CLUTCH BELL	-	7711207	7711207	7711207
	CLUTCH BELL (FINNED RING)		€33,45 Ø 107	€33,45 Ø 107	€33,45 Ø 107
	FLY SYSTEM	-	5214111	5214111	5214111
	CLUTCH BELL + NOT ADJUSTABLE CLUTCH		€63,00 Ø 107	€63,00 Ø 107	€63,00 Ø 107
	DELTA SYSTEM	-	5214110	5214110	5214110
	CLUTCH BELL + ADJUSTABLE CLUTCH		€93,84 Ø 107	€93,84 Ø 107	€93,84 Ø 107
	SPORT SPRINGS	29 8746	29 8746	29 8746	29 8746
	FOR FLY / DELTA CLUTCH	€14,50	€14,50	€14,50	€14,50
	MHR SPRINGS	29 8747	29 8747	29 8747	29 8747
	FOR FLY / DELTA CLUTCH	€19,40	€19,40	€19,40	€19,40
	SPRINGS Ø INTERNAL CLUTCH BELL 105-107	29 7715	29 7454	29 7454	29 7454
	FOR ORIGINAL CLUTCH	€16,20	€16,20	€16,20	€16,20
	MUELLES Ø INTERNAL CLUTCH BELL 112	-	-	-	-
	FOR ORIGINAL CLUTCH				

18 - To be assembled EXCLUSIVELY with MALOSSİ EXHAUST SYSTEMS

35 - IT CAN BE ASSEMBLED WITH NO MODIFICATION to the original system, EVEN ON vehicles PRODUCED 2001->

GILERA

RUNNER	RUNNER PureJet <-2005	RUNNER PureJet 2006->	RUNNER SP <-2005	RUNNER SP 2006->	STALKER	STORM	TYPHOON
				(C451M)			
50 2T LC	50 2T LC	50 2T LC	50 2T LC	50 2T LC	50 2T LC	50 2T	50 2T
31 8523 € 164,21 Ø 40 (12)	-	-	31 8523 € 164,21 Ø 40 (12)	31 8523 € 164,21 Ø 40 (12)	31 8520 € 124,91 Ø 40 (12)	31 8520 € 124,91 Ø 40 (12)	31 8520 € 124,91 Ø 40 (12)
31 7353 € 176,03 Ø 47 (12)	3112044 € 305,23 Ø 47 (12)	3112044 € 305,23 Ø 47 (12)	31 7353 € 176,03 Ø 47 (12)	31 7353 € 176,03 Ø 47 (12)	31 6926 € 120,25 Ø 47 (12)	31 6926 € 120,25 Ø 47 (12)	31 6926 € 120,25 Ø 47 (12)
-	-	-	-	-	31 6915 € 100,86 Ø 47 (12)	31 6915 € 100,86 Ø 47 (12)	31 6915 € 100,86 Ø 47 (12)
-	-	-	-	-	38 7118 € 37,45 Ø 47	38 7118 € 37,45 Ø 47	38 7118 € 37,45 Ø 47
31 8466 € 239,46 Ø 47 (12)	-	-	31 8466 € 239,46 Ø 47 (12)	31 8466 € 239,46 Ø 47 (12)	31 8463 € 207,00 Ø 47 (12)	31 8463 € 207,00 Ø 47 (12)	31 8463 € 207,00 Ø 47 (12)
-	-	-	-	-	-	-	-
53 7600 € 175,50	5312331 € 301,56	5312331 € 301,56	53 7600 € 175,50	53 7600 € 175,50	53 7600 € 175,50	53 7600 € 175,50	53 7600 € 175,50
6614105E € 43,00	6614105E € 43,00	6614105E € 43,00	6614105E € 43,00	6614105E € 43,00	6614105E € 43,00	6614105E € 43,00	6614105E € 43,00
5513195 *35* € 92,82	PG.422	PG.422	5513195 *35* € 92,82	5513195 *35* € 92,82	5513195 *35* € 92,82	5513195 *35* € 92,82	5513195 *35* € 92,82
5513196 *35* € 140,51	-	-	5513196 *35* € 140,51	5513196 *35* € 140,51	5513196 *35* € 140,51	5513196 *35* € 140,51	5513196 *35* € 140,51
51 9019 € 61,80 51 9448 1997 € 60,00	51 9019 € 61,80	51 9019 € 61,80	51 9019 € 61,80 51 9448 1997 € 60,00	51 9019 € 61,80 51 9448 1997 € 60,00	51 9019 € 61,80 51 9448 1997 € 60,00	51 7382 € 58,71	51 7382 € 58,71
61 9831 € 19,49	61 9831 € 19,49	61 9831 € 19,49	61 9831 € 19,49	61 9831 € 19,49	61 9831 € 19,49	61 9832 € 17,04	61 9832 € 17,04
6114118 € 38,25	6114118 € 38,25	6114118 € 38,25	6114118 € 38,25	6114118 € 38,25	6114118 € 38,25	61 7587 € 28,25	61 7587 € 28,25
66 9420.M0 € 10,00 gr.07,2	66 9420.M0 € 10,00 gr.07,2	66 9420.M0 € 10,00 gr.07,2	66 9420.M0 € 10,00 gr.07,2	66 9420.M0 € 10,00 gr.07,2	66 9420.M0 € 10,00 gr.07,2	66 9823.N0 € 9,50 gr.08	66 9823.N0 € 9,50 gr.08
66 9420.N0 € 10,00 gr.07,5	66 9420.I0 € 10,00 gr.06,5	66 9420.E0 € 10,00 gr.05,5	66 9420.N0 € 10,00 gr.07,5	66 9420.I0 € 10,00 gr.06,5	66 9420.N0 € 10,00 gr.07,5	66 9823.R0 € 9,50 gr.08,5	66 9823.R0 € 9,50 gr.08,5
-	-	-	-	-	-	-	-
PG.438	PG.438	PG.438	PG.438	PG.438	PG.438	PG.438	PG.438
2512828 € 4,45	2512828 € 4,45	2512828 € 4,45	2512828 € 4,45	2512828 € 4,45	2512828 € 4,45	2512828 € 4,45	2512828 € 4,45
61 9100 € 85,57	61 9100 € 85,57	61 9100 € 85,57	61 9100 € 85,57	61 9100 € 85,57	61 9100 € 85,57	61 8233 € 85,57	61 8233 € 85,57
52 8797 € 47,30	52 8797 € 47,30	52 8797 € 47,30	52 8797 € 47,30	52 8797 € 47,30	52 8797 € 47,30	52 8797 € 47,30	52 8797 € 47,30
52 7880 € 77,89	52 7880 € 77,89	52 7880 € 77,89	52 7880 € 77,89	52 7880 € 77,89	52 7880 € 77,89	52 7880 € 77,89	52 7880 € 77,89
7711115 € 22,60 Ø 107	7711115 € 22,60 Ø 107	7711115 € 22,60 Ø 107	7711115 € 22,60 Ø 107	7711115 € 22,60 Ø 107	7711115 € 22,60 Ø 107	7711115 € 22,60 Ø 107	7711115 € 22,60 Ø 107
7711207 € 33,45 Ø 107	7711207 € 33,45 Ø 107	7711207 € 33,45 Ø 107	7711207 € 33,45 Ø 107	7711207 € 33,45 Ø 107	7711207 € 33,45 Ø 107	7711207 € 33,45 Ø 107	7711207 € 33,45 Ø 107
5214111 € 63,00 Ø 107	5214111 € 63,00 Ø 107	5214111 € 63,00 Ø 107	5214111 € 63,00 Ø 107	5214111 € 63,00 Ø 107	5214111 € 63,00 Ø 107	5214111 € 63,00 Ø 107	5214111 € 63,00 Ø 107
5214110 € 93,84 Ø 107	5214110 € 93,84 Ø 107	5214110 € 93,84 Ø 107	5214110 € 93,84 Ø 107	5214110 € 93,84 Ø 107	5214110 € 93,84 Ø 107	5214110 € 93,84 Ø 107	5214110 € 93,84 Ø 107
29 8746 € 14,50	29 8746 € 14,50	29 8746 € 14,50	29 8746 € 14,50	29 8746 € 14,50	29 8746 € 14,50	29 8746 € 14,50	29 8746 € 14,50
29 8747 € 19,40	29 8747 € 19,40	29 8747 € 19,40	29 8747 € 19,40	29 8747 € 19,40	29 8747 € 19,40	29 8747 € 19,40	29 8747 € 19,40
29 7454 € 16,20	29 7454 € 16,20	29 7454 € 16,20	29 7454 € 16,20	29 7454 € 16,20	29 7454 € 16,20	29 7454 € 16,20	29 7454 € 16,20
-	-	-	-	-	-	-	-



MALOSSİ

Scooter 2T

with ENGINE **GARELLI****GILERA**TIESSE 50R
euro 2

DNA

EASY MOVING

ICE

(1E40QMB)

50 2T



50 2T













LC

50 2T

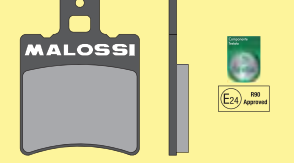
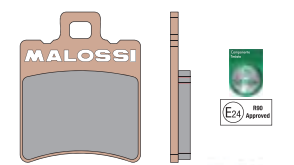

50 2T

**() CHECK "TYPE" SPECIFICATION (HOMOLOGATION MARK)**

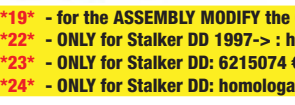
	CARBURETTOR		72 9215 € 78,76 Ø 17,5	-	72 7084 € 75,17 Ø 17,5	72 7084 € 75,17 Ø 17,5
	CARBURETTOR KIT	Ø 19	1611042 € 118,04	1611040 € 118,04	1611040 € 118,04	1611040 € 118,04
	CARBURETTOR KIT	Ø 21	1610995 € 114,23	1610997 € 114,23	1610997 € 114,23	1610997 € 114,23
	CARBURETTOR KIT	Ø 22	-	1611029 € 96,77	1611029 € 96,77	1611029 € 96,77
	REED VALVE CARBON FIBRE		27 7731.CO *19* € 48,95 VL12	27 7708.CO € 48,95 VL11	27 7708.CO € 48,95 VL11	27 7708.CO € 48,95 VL11
	PETALS SET FOR ORIGINAL REED VALVE		27 7054.CO € 18,71	27 7054.CO € 18,71	27 7054.CO € 18,71	27 7054.CO € 18,71
	ART OF PERFORMANCE / FLIP HOMOLOGATED 	PG. 426	-	-	-	-
	WILD LION HOMOLOGATED 	PG. 424	-	-	3216590 € 87,00	-
	RED SPONGE FOR ORIGINAL AIR BOX		1414044 € 3,56	1411778 € 3,54	-	1411778 € 3,54
	DOUBLE RED SPONGE FOR ORIGINAL AIR BOX		1414483 € 5,30	1414497 € 6,16	-	1414497 € 6,16
	GEARS HTQ PRIMARY		-	6711602 € 69,34 z 14/48	67 8727 z16/37 (17) € 57,67 67 7385 (18) € 56,53	67 9080 z 14/39 € 60,41 6713339 z 15/38 € 61,71
	GEARS HTQ SECONDARY	PG. 478	-	-	-	67 9966 *PG* € 65,00 z 13/48
	ROLLER CRANKCASE		-	-	-	2514521 *66* € 95,00
	SCREEN		-	-	-	-
	BRAKE PADS	FRONT	-	-	6215042 € 5,72 1995->	6215042 € 5,72 2000->
	BRAKE PADS MHR	FRONT	-	-	6215080 € 6,00 1995->	6215080 € 6,00 2000->
	BRAKE PADS MHR SYNT	FRONT	-	6215011 € 16,00 2000->	6215007 € 11,96 1995->	6215007 € 11,96 2000->
	BRAKE PADS	REAR	-	-	-	-
	BRAKE PADS MHR	REAR	-	-	-	-
	BRAKE PADS MHR SYNT	REAR	-	6215015 € 16,64 2000->	-	-
	BRAKE POWER	REAR	-	-	6215806 € 15,00 1995->	6215328 € 18,39 2000->
	BRAKE SHOES	FRONT	-	-	-	-
	WHOOP DISC	FRONT	6212603 € 72,56	6212351 € 88,30 2000->	6214097 € 62,00 1995->	-
	WHOOP DISC	REAR	-	6212604 € 76,38 2000->	-	-
	RS1 - RS3	REAR SHOCK ABSORBER	4615433 € 90,78 46 8610 € 141,25	-	4615432 € 94,86 46 7908 € 140,92	-
	RS24 - RS24/10	FRONT SHOCK ABSORBER	-	-	-	-
	RS24 - RS24/10 - RS24/10-R	REAR SHOCK ABSORBER	46 8611 € 219,76	4611641 € 263,94	46 8308 € 248,50 4614237 € 428,82	-
	RS24	FRONT + REAR	-	-	-	-
	HORQUILLA F32S	FORK STEMS Ø 32	-	-	-	-
	HORQUILLA F37R MHR	FORK STEMS Ø 37	-	-	-	-

19 - for the ASSEMBLY MODIFY the CRANKCASE

22 - ONLY for Stalker DD 1997-> : homologated 6215049 € 6,24

23 - ONLY for Stalker DD: 6215074 € 6,30

24 - ONLY for Stalker DD: homologated 6215006 € 11,96

GILERA

GILERA							
RUNNER	RUNNER PureJet <-2005	RUNNER PureJet 2006->	RUNNER SP <-2005	RUNNER SP 2006->	STALKER	STORM	TYPHOON
				(C451M)			
50 2T LC	50 2T LC	50 2T LC	50 2T LC	50 2T LC	50 2T	50 2T	50 2T
72 7084 € 75,17 Ø 17,5	-	-	72 7084 € 75,17 Ø 17,5	72 7084 € 75,17 Ø 17,5	72 7084 € 75,17 Ø 17,5	72 7084 € 75,17 Ø 17,5	72 7084 € 75,17 Ø 17,5
1611040 € 118,04	-	-	1611040 € 118,04	1611040 € 118,04	1611040 € 118,04	1611040 € 118,04	1611040 € 118,04
1610997 € 114,23	-	-	1610997 € 114,23	1610997 € 114,23	1610997 € 114,23	1610997 € 114,23	1610997 € 114,23
1611029 € 96,77	-	-	1611029 € 96,77	1611029 € 96,77	1611029 € 96,77	1611029 € 96,77	1611029 € 96,77
27 7708.C0 € 48,95 VL11	27 7708.C0 € 48,95 VL11	27 7708.C0 € 48,95 VL11	27 7708.C0 € 48,95 VL11	27 7708.C0 € 48,95 VL11	27 7708.C0 € 48,95 VL11	27 7708.C0 € 48,95 VL11	27 7708.C0 € 48,95 VL11
27 7054.C0 € 18,71	27 7054.C0 € 18,71	27 7054.C0 € 18,71	27 7054.C0 € 18,71	27 7054.C0 € 18,71	27 7054.C0 € 18,71	27 7054.C0 € 18,71	27 7054.C0 € 18,71
3215167 € 175,70 3216692 € 122,00	3215167 € 175,70 3216692 € 122,00	-	3215167 € 175,70 3216692 € 122,00	-	3215167 € 175,70 3216692 € 122,00	-	3215167 € 175,70 3216692 € 122,00
3216582 € 87,00	3216582 € 87,00	-	3216582 € 87,00	-	-	3216580 € 87,00	3216580 € 87,00
1411423 € 4,13	1412205 € 5,77	-	1411423 € 4,13	1411778 € 3,54	1411423 € 4,13	1411422 € 4,29	1411422 € 4,29
1414505 € 6,25	-	-	1414505 € 6,25	1414497 € 6,16	1414505 € 6,25	1414506 € 6,65	1414506 € 6,65
67 9080 z 14/39 € 60,41 6713339 z 15/38 € 61,71	67 9080 z 14/39 € 60,41 6713339 z 15/38 € 61,71	67 9080 z 14/39 € 60,41 6713339 z 15/38 € 61,71	67 9080 z 14/39 € 60,41 6713339 z 15/38 € 61,71	67 9080 z 14/39 € 60,41 6713339 z 15/38 € 61,71	67 9080 z 14/39 € 60,41 6713339 z 15/38 € 61,71	67 8218 z14/39 (18) € 56,53 67 8220 (17) € 56,53	67 8218 z14/39 (18) € 56,53 67 8220 (17) € 56,53
PG.478	67 9966 € 65,00 z 13/48	67 9966 € 65,00 z 13/48	PG.478	67 9966 *PG* € 65,00 z 13/48	PG.478	67 8938 *PG* € 60,41 z13/48 (17)	67 8938 *PG* € 60,41 z13/48 (17)
2514521 *66* € 95,00	2514521 *66* € 95,00	2514521 *66* € 95,00	2514521 *66* € 95,00	2514521 *66* € 95,00	2514521 *66* € 95,00	-	-
-	-	-	-	-	-	-	-
6215042 € 5,72 1997->	6215042 € 5,72	6215062 € 8,32	6215042 € 5,72 1998->99	6215062 € 8,32	6215042 € 5,72 1997->	6215042 € 5,72 1994->	6215042 € 5,72 1993->
6215080 € 6,00 1997->	6215080 € 6,00	6215079 € 8,20	6215080 € 6,00 1998->99	6215079 € 8,20	6215080 € 6,00 1997->	6215080 € 6,00 1994->	6215080 € 6,00 1993->
6215007 € 11,96 1997->	6215007 € 11,96	6215013 € 16,50	6215011 2000->€ 16,00 6215007 1998->99 € 11,96	6215013 € 16,50	6215007 € 11,96 1997->	6215007 € 11,96 1994->	6215007 € 11,96 1993->
-	-	6215049 € 6,24	6215049 € 6,24 1998->	6215049 € 6,24	*22*	-	-
-	-	6215074 € 6,30	6215074 € 6,30 1998->	6215074 € 6,30	*23*	-	-
-	-	6215006 € 11,96	6215006 € 11,96 1998->	6215006 € 11,96	*24*	-	-
-	-	-	-	-	6215328 € 18,39 1997->	6215806 € 15,00 1994->	6215806 1995-> € 15,00 62 7843 1993->94 € 15,44
6212929 € 105,00 1997->	6212929 € 105,00	-	6212929 € 105,00 1998->99	*81*	6212603 € 72,56 1997->	6212603 € 72,56 1994->	6212603 € 72,56 1993->
-	-	-	-	-	-	-	-
4615432 € 94,86 46 7908 € 140,92	4615432 € 94,86 46 7908 € 140,92	4615432 € 94,86 46 7908 € 140,92	4615432 € 94,86 46 7908 € 140,92	4615432 € 94,86 46 7908 € 140,92	4615432 € 94,86 46 7908 € 140,92	4615432 € 94,86 46 7908 € 140,92	4615432 € 94,86 46 7908 € 140,92
-	-	-	-	-	-	-	-
46 8308 € 248,50 4614237 € 428,82	46 8308 € 248,50 4614237 € 428,82	46 8308 € 248,50 4614237 € 428,82	46 8308 € 248,50 4614237 € 428,82	46 8308 € 248,50 4614237 € 428,82	46 8308 € 248,50	46 8308 € 248,50 4614237 € 428,82	46 8308 € 248,50
-	-	-	-	-	-	-	-
46 9552 € 563,41	46 9552 € 563,41	4613086 € 649,03	46 9552 € 563,41	4613086 € 649,03	-	46 9550 € 591,80	46 9550 € 591,80
-	-	4616136 € 1122,00	-	4616136 € 1122,00	-	-	-

66 - NOT to be used on VEHICLE WITH ORIGINAL PRIMARY GEARS
 81 - OVERSIZED WHOOP DISC KIT ext. Ø 250 - thickness 3 mm/ BRAKE CALIPER SUPP. CLAMP for ORIGINAL FORK, IS ALSO AVAILABLE: 6213085 € 156,00
 PG - SPECIFICATIONS on the PAGE indicated in the TITLE of the LINE



MALOSSI

Scooter 2T

with ENGINE 

GILERA

HONDA

TYPHOON X

BALI

BALI

DIO G

(▲) ATTENTION: ONLY FOR vehicles WITHOUT IMMOBILIZER KEY50 2T 50 2T 100 2T 50 2T 

	CYLINDER+HEAD CAST-IRON Ø 40	31 8520	-	-	-
	(pin) ALUMINIUM Ø 40-41	€124,91 Ø 40 (12)			
	CYLINDER+HEAD	31 6926	31 8734	-	31 7200
	(pin) CAST-IRON Ø 47	€120,25 Ø 47 (12)	€117,23 Ø 47 (12)		€123,02 Ø 47 (12)
	CYLINDER CAST-IRON Ø 47-57,5	31 6915	31 7748	-	31 6998
	for ORIGINAL HEAD ALUM. Ø 47>57,5	€100,86 Ø 47 (12)	€104,07 Ø 47 (12)		€104,07 Ø 47 (12)
	HEAD HTSR	38 7118	38 7757	-	38 7007
	for Malossi CYLINDER	€37,45 Ø 47	€37,45 Ø 47		€37,45 Ø 47
	CYLINDER+HEAD MHR Replica ALUMINIUM	31 8463	-	-	31 8473
	(pin) Ø 47	€207,00 Ø 47 (12)			€217,30 Ø 47 (12)
	CRANKSHAFTS RHQ	-	-	-	-
	PIN Ø 10				
	CRANKSHAFTS RHQ	53 7600	53 8624	-	53 7814
	PIN Ø 12	€175,50	€173,09		€188,00
	RADIAL ROLLER BEARING	6614105E	-	-	-
	FOR CRANKSHAFT	PG. 473 €43,00			
	ELECTRONIC CONTROLLER	5513195 *35*	55 8176	-	55 8176
		€92,82	€51,33		€51,33
	ELECTRONIC CONTROLLER	5513196 *35*	-	-	-
	RPM CONTROL	€140,51			
	MULTIVAR	51 9019 €61,80	51 7117	5111364	51 7072
	VARIATOR	51 9448 1997 €60,00	€58,71	€62,83	€58,71
	X SPECIAL BELT	61 9831	61 8396	-	-
	BELT	€19,49	€14,68		
	X K BELT	6114118	61 7221	-	61 7211
	BELT	€38,25	€24,41		€25,68
	HTRoll	66 9420.M0	66 9823.N0	66 9420.K0	66 9823.M0
	ROLLERS FOR MULTIVAR	€10,00 gr.07,2	€9,50 gr.08	€10,00 gr.12	€9,50 gr.07
	HTRoll	66 9420.N0	66 9823.R0	66 9823.P0	66 9823.R0
	ROLLERS FOR ORIGINAL VARIATOR	€10,00 gr.07,5	€9,50 gr.08,5	€9,50 gr.10	€9,50 gr.08,5
	VENTILVAR	-	-	-	-
	FIXED HALF-PULLEY				
	VARIABLE-SPEED DRIVE ADJUSTER SPRING	PG. 438 PG.438	PG.438	-	PG.438
	FOR VARIATOR				
	TORSION CONTROLLER	2512828	2512828	-	2512828
	ANTIFRICTION FIFTH WHEEL	€4,45	€4,45		€4,45
	TORQUE DRIVER	61 9100	61 8317	-	61 8317
	MOBILE DRIVEN SPLIT PULLEY	€85,57	€95,61		€95,61
	FLY CLUTCH	52 8797	52 8797	-	52 8797
	NOT ADJUSTABLE CLUTCH	€47,30	€47,30		€47,30
	DELTA CLUTCH	52 7880	52 7880	-	52 7880
	ADJUSTABLE CLUTCH	€77,89	€77,89		€77,89
	CLUTCH BELL	7711115	7711115	-	7711115
	CLUTCH BELL (SMOOTH RING)	€22,60 Ø 107	€22,60 Ø 107		€22,60 Ø 107
	WING CLUTCH BELL	7711207	-	-	-
	CLUTCH BELL (FINNED RING)	€33,45 Ø 107			
	FLY SYSTEM	5214111	5214111	-	5214111
	CLUTCH BELL + NOT ADJUSTABLE CLUTCH	€63,00 Ø 107	€63,00 Ø 107		€63,00 Ø 107
	DELTA SYSTEM	5214110	-	-	-
	CLUTCH BELL + ADJUSTABLE CLUTCH	€93,84 Ø 107			
	SPORT SPRINGS	29 8746	29 8746	-	29 8746
	FOR FLY / DELTA CLUTCH	€14,50	€14,50		€14,50
	MHR SPRINGS	29 8747	29 8747	-	29 8747
	FOR FLY / DELTA CLUTCH	€19,40	€19,40		€19,40
	SPRINGS Ø INTERNAL CLUTCH BELL 105-107	29 7454	29 7454	-	29 7454
	FOR ORIGINAL CLUTCH	€16,20	€16,20 <-1996		€16,20 <-1996
	MUELLES Ø INTERNAL CLUTCH BELL 112	-	29 9605	-	29 9605
	FOR ORIGINAL CLUTCH		€16,20 1997->		€16,20 1997->

35 - IT CAN BE ASSEMBLED WITH NO MODIFICATION to the original system, EVEN ON vehicles PRODUCED 2001->

HONDA

DIO SP		DIO SR		DIO ZX <-1993		DIO ZX 1994->		SFX		SGX SKY		SH <-1995		SH 1996->	
50 2T	🔥	50 2T	🔥	50 2T	🔥	50 2T	🔥	50 2T	🔥	50 2T	🔥	50 2T	🔥	50 2T	🔥
-		-		-		-		-		-		-		-	
31 7200		31 7200		31 7200		-		31 8734		31 8734		-		31 8734	
€123,02 Ø 47 (12)		€123,02 Ø 47 (12)		€123,02 Ø 47 (12)				€117,23 Ø 47 (12)		€117,23 Ø 47 (12)				€117,23 Ø 47 (12)	
31 6998		31 6998		31 6998		31 8286		31 7748		31 7748		31 6170	1	31 7748	
€104,07 Ø 47 (12)		€104,07 Ø 47 (12)		€104,07 Ø 47 (12)		€113,73 Ø 47 (12)		€104,07 Ø 47 (12)		€104,07 Ø 47 (12)		€95,13 Ø 47 (10)		€104,07 Ø 47 (12)	
38 7007		38 7007		38 7007		-		38 7757		38 7757		38 7716		38 7757	
€37,45 Ø 47		€37,45 Ø 47		€37,45 Ø 47				€37,45 Ø 47		€37,45 Ø 47		€42,32 Ø 47		€37,45 Ø 47	
31 8473		31 8473		31 8473		-		-		-		-		-	
€217,30 Ø 47 (12)		€217,30 Ø 47 (12)		€217,30 Ø 47 (12)											
-		-		-		-		-		-		53 8053		-	
												€96,13			
53 7814		53 7814		53 7604		53 8417		53 8624		-		53 8123		-	
€188,00		€188,00		€185,00		€211,37		€173,09				€96,13			
-		-		-		-		-		-		-		-	
55 8176		55 8132		55 8176		-		-		-		-		-	
€51,33		€50,14		€51,33											
-		55 8675		-		55 8349		55 8627		-		-		55 8627	
		€104,38				€135,02		€130,37						€130,37	
51 7073		51 7073		51 7484		51 7484		51 7117		51 7117		51 7074		51 7117	
€58,71		€58,71		€58,71		€58,71		€58,71		€58,71		€58,71		€58,71	
-		-		-		-		61 8396		61 9221		61 7233		61 9221	
								€14,68		€18,68		€12,90		€18,68	
61 7215		61 7215		61 7211		61 7211		61 7221		61 9463		-		61 9463	
€23,50		€23,50		€25,68		€25,68		€24,41		€28,02				€28,02	
66 9823.M0		66 9823.M0		66 9823.M0		66 9823.M0		66 9823.N0		66 9823.N0		66 9823.L0		66 9823.N0	
€9,50 gr.07		€9,50 gr.07		€9,50 gr.07		€9,50 gr.07		€9,50 gr.08		€9,50 gr.08		€9,50 gr.06		€9,50 gr.08	
66 9823.R0		66 9823.R0		66 9823.R0		66 9823.R0		66 9823.O0		66 9823.I0		-		66 9823.O0	
€9,50 gr.08,5		€9,50 gr.08,5		€9,50 gr.08,5		€9,50 gr.08,5		€9,50 gr.09		€9,50 gr.05,1				€9,50 gr.09	
-		-		-		-		-		-		61 7377		-	
												€22,48			
PG.438		PG.438		PG.438		PG.438		PG.438		PG.438		PG.438		PG.438	
2512828		2512828		2512828		2512828		2512828		2512828		-		2512828	
€4,45		€4,45		€4,45		€4,45		€4,45		€4,45				€4,45	
-		-		61 8317		61 8317		61 8317		61 8317		-		61 8317	
				€95,61		€95,61		€95,61		€95,61				€95,61	
-		-		52 8797		52 8797		52 8797		52 8797		-		52 8797	
				€47,30		€47,30		€47,30		€47,30				€47,30	
-		-		52 7880		52 7880		52 7880		52 7880		-		52 7880	
				€77,89		€77,89		€77,89		€77,89				€77,89	
7711115		7711115		7711115		7711115		7711115		7711115		-		7711115	
€22,60 Ø 107		€22,60 Ø 107		€22,60 Ø 107		€22,60 Ø 107		€22,60 Ø 107		€22,60 Ø 107				€22,60 Ø 107	
-		-		-		-		-		-		-		-	
-		-		5214111		5214111		5214111		5214111		-		5214111	
				€63,00 Ø 107		€63,00 Ø 107		€63,00 Ø 107		€63,00 Ø 107				€63,00 Ø 107	
-		-		-		-		-		-		-		-	
-		-		29 8746		29 8746		29 8746		29 8746		-		29 8746	
				€14,50		€14,50		€14,50		€14,50				€14,50	
-		-		29 8747		29 8747		29 8747		29 8747		-		29 8747	
				€19,40		€19,40		€19,40		€19,40				€19,40	
29 7456		29 7456		29 7454		29 7454		29 7454		29 7454		29 7456		29 7456	
€16,20		€16,20		€16,20		€16,20		€16,20 <-1996		€16,20 <-1996		€16,20		€16,20	
-		-		-		-		29 9605		29 9605		-		-	
								€16,20 1997->		€16,20 1997->					



MALOSSI

Scooter 2T

with ENGINE **GILERA****HONDA**

TYPHOON X

BALI

BALI

DIO G

50 2T



50 2T















100 2T

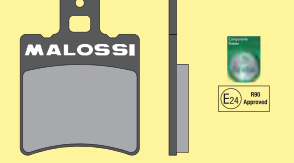
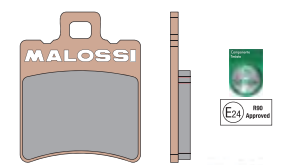

50 2T

**() CHECK "TYPE" SPECIFICATION (HOMOLOGATION MARK)**

	CARBURETTOR		72 7084 € 75,17 Ø 17,5	-	-	-
	CARBURETTOR KIT	Ø 19	1611040 € 118,04	1611016 € 115,99 1996->	-	1610990 € 115,22
	CARBURETTOR KIT	Ø 21	1610997 € 114,23	-	-	-
	CARBURETTOR KIT	Ø 22	1611029 € 96,77	-	-	-
	REED VALVE CARBON FIBRE		27 7708.CO € 48,95 VL11	27 7440.CO € 49,00 VL9	-	27 7440.CO € 49,00 VL9
	PETALS SET FOR ORIGINAL REED VALVE		27 7054.CO € 18,71	27 2728.CO € 16,27	-	27 2728.CO € 16,27
	ART OF PERFORMANCE / FLIP HOMOLOGATED 		-	-	-	-
	WILD LION HOMOLOGATED 		-	-	-	-
	RED SPONGE FOR ORIGINAL AIR BOX		-	-	-	-
	DOUBLE RED SPONGE FOR ORIGINAL AIR BOX		-	-	-	-
	GEARS HTQ PRIMARY		67 9080 z 14/39 € 60,41 6713339 z 15/38 € 61,71	67 7758 € 51,19 z 17/39	-	-
	GEARS HTQ SECONDARY		67 9966 *PG* € 65,00 z 13/48	-	-	-
	ROLLER CRANKCASE		2514521 *66* € 95,00	-	-	-
	SCREEN		-	-	-	-
	BRAKE PADS	FRONT	6215042 € 5,72 1993->	6215048 € 8,32 1993->	6215048 € 8,32 1998->	62 9014 € 8,10 1991->
	BRAKE PADS MHR	FRONT	6215080 € 6,00 1993->	62 9098 € 8,10 1993->	62 9098 € 8,10 1998->	62 9085 € 8,32 1991->
	BRAKE PADS MHR SYNT	FRONT	6215007 € 11,96 1993->	6215031 € 17,16 1993->	6215031 € 17,16 1998->	-
	BRAKE PADS	REAR	-	-	-	-
	BRAKE PADS MHR	REAR	-	-	-	-
	BRAKE PADS MHR SYNT	REAR	-	-	-	-
	BRAKE POWER	REAR	6215328	6215802	-	6215899
	BRAKE SHOES	FRONT	€ 18,39 1993->	€ 18,64 1993->	-	€ 20,00 1991->
	WHOOOP DISC	FRONT	6212603 € 72,56 1993->	6212603 € 72,56 1993->	-	62 8960 € 60,68 1991->
	WHOOOP DISC	REAR	-	-	-	-
	RS1 - RS3	REAR SHOCK ABSORBER	4615432 € 94,86 46 7908 € 140,92	-	-	46 7905 € 140,92 RS3
	RS24 - RS24/10	FRONT SHOCK ABSORBER	-	-	-	-
	RS24 - RS24/10 - RS24/10-R	REAR SHOCK ABSORBER	46 8308 € 248,50 RS24	-	-	46 7588 € 255,97 RS24
	RS24	FRONT + REAR	-	-	-	-
	HORQUILLA F32S	FORK STEMS Ø 32	46 9550 € 591,80	-	-	-
	HORQUILLA F37R MHR	FORK STEMS Ø 37	-	-	-	-

66 - NOT to be used on VEHICLE WITH ORIGINAL PRIMARY GEARS

PG - SPECIFICATIONS on the PAGE indicated in the TITLE of the LINE

HONDA

225

DIO SP		DIO SR		DIO ZX <-1993		DIO ZX 1994->		SFX		SGX SKY		SH <-1995		SH 1996->	
50 2T		50 2T		50 2T		50 2T		50 2T		50 2T		50 2T		50 2T	
-	-	-	-	-	-	-	-	-	-	-	-	-	-	-	-
1611001 € 112,10	1611001 € 112,10	1611001 € 112,10	1611001 € 112,10	1611001 € 112,10	1611001 € 112,10	1611001 € 112,10	1611001 € 112,10	1611001 € 112,10	1611001 € 112,10	1611001 € 112,10	1610923 € 99,17	1611016 € 115,99	-	-	-
-	-	-	-	-	-	-	-	-	-	-	-	-	-	-	-
-	-	-	-	-	-	-	-	-	-	-	-	-	-	-	-
27 7440.C0 € 49,00 VL9	27 7440.C0 € 49,00 VL9	27 7440.C0 € 49,00 VL9	-	-	-	27 7440.C0 € 49,00 VL9	27 7440.C0 € 49,00 VL9	27 7440.C0 € 49,00 VL9	27 7440.C0 € 49,00 VL9	27 7440.C0 € 49,00 VL9	27 7440.C0 € 49,00 VL9	27 7440.C0 € 49,00 VL9	27 7440.C0 € 49,00 VL9	27 7440.C0 € 49,00 VL9	27 7440.C0 € 49,00 VL9
27 2728.C0 € 16,27	27 2728.C0 € 16,27	27 2728.C0 € 16,27	-	-	-	27 2728.C0 € 16,27	27 2728.C0 € 16,27	27 2728.C0 € 16,27	27 2728.C0 € 16,27	27 2728.C0 € 16,27	27 1090.C0 € 14,90	27 2728.C0 € 16,27	-	-	-
-	-	-	-	-	-	-	-	-	-	-	-	-	-	-	-
-	-	-	-	-	-	-	-	-	-	-	-	-	-	-	-
-	-	-	-	-	-	-	1411410 € 4,54	-	-	-	-	-	1411409 € 4,38	-	-
-	-	-	-	-	-	-	-	-	-	-	-	-	-	-	-
-	-	-	-	-	-	-	67 8700 € 60,44 z 19/37	67 9050 € 66,85 z 16/40	67 9050 € 66,85 z 16/40	67 9050 € 66,85 z 16/40	67 1377 € 52,23 z 16/32	67 9050 € 66,85 z 16/40	67 9050 € 66,85 z 16/40	-	-
-	-	-	-	-	-	-	-	-	-	-	-	-	-	-	-
-	-	-	-	-	-	-	-	-	-	-	-	-	-	-	-
-	-	-	-	-	-	-	-	-	-	-	-	-	-	-	-
62 9014 € 8,10 1993->	62 9014 € 8,10 1990->	-	-	-	-	6215042 € 5,72 1995->	6215042 € 5,72 1995->	6215042 € 5,72 2000->	6215042 € 5,72 2000->	6215042 € 5,72 2000->	-	6215042 € 5,72 1997->	-	-	-
62 9085 € 8,32 1993->	62 9085 € 8,32 1990->	-	-	-	-	6215080 € 6,00 1995->	6215080 € 6,00 1995->	6215080 € 6,00 2000->	6215080 € 6,00 2000->	6215080 € 6,00 2000->	-	6215080 € 6,00 1997->	-	-	-
-	-	-	-	-	-	6215007 € 11,96 1995->	6215007 € 11,96 1995->	6215007 € 11,96 2000->	6215007 € 11,96 2000->	6215007 € 11,96 2000->	-	6215007 € 11,96 1997->	-	-	-
-	-	-	-	-	-	-	-	-	-	-	-	-	-	-	-
-	-	-	-	-	-	-	-	-	-	-	-	-	-	-	-
-	-	-	-	-	-	-	-	-	-	-	-	-	-	-	-
6215899 € 20,00 1993->	6215899 € 20,00 1990->	6215899 € 20,00	6215899 € 20,00	6215899 € 20,00	6215899 € 20,00	6215802 € 18,64 1995->	6215802 € 18,64 1995->	6215802 € 18,64 2000->	6215802 € 18,64 2000->	6215802 € 18,64 2000->	62 7845 <-1995 € 17,04	6215802 € 18,64 1997->	6215802 € 18,64 <-1995 € 18,64	6215802 € 18,64 1997->	-
62 8960 € 60,68 1993->	62 8960 € 60,68 1990->	62 8960 € 60,68	62 8960 € 60,68	62 8960 € 60,68	62 8960 € 60,68	62 9096 € 69,31 1995->	62 9096 € 69,31 1995->	6212603 € 72,56 2000->	6212603 € 72,56 2000->	6212603 € 72,56 2000->	-	-	-	-	-
-	-	-	-	-	-	-	-	-	-	-	-	-	-	-	-
46 7905 € 140,92 RS3	46 7905 € 140,92 RS3	46 7905 € 140,92 RS3	-	-	-	46 7905 € 140,92 RS3	46 7905 € 140,92 RS3	4615433 € 90,78 46 8610 € 141,25	4615433 € 90,78 46 8610 € 141,25	4615433 € 90,78 46 8610 € 141,25	-	-	-	-	-
-	-	-	-	-	-	-	-	-	-	-	-	-	-	-	-
46 7588 € 255,97 RS24	46 7588 € 255,97 RS24	46 7588 € 255,97 RS24	-	-	-	46 7588 € 255,97 RS24	46 7588 € 255,97 RS24	46 8611 € 219,76 RS24	46 8611 € 219,76 RS24	46 8611 € 219,76 RS24	-	-	-	-	-
-	-	-	-	-	-	-	-	-	-	-	-	-	-	-	-
-	-	-	-	-	-	-	-	-	-	-	-	-	-	-	-
-	-	-	-	-	-	-	-	-	-	-	-	-	-	-	-

SCOOTER 2T



MALOSSI

Scooter 2T

with ENGINE **HONDA**

SH

SHADOW

SXR

VISION

100 2T



50 2T



50 2T



50 2T

**(▲) ATTENTION: ONLY FOR vehicles WITHOUT IMMOBILIZER KEY**

	CYLINDER+HEAD CAST-IRON Ø 40	-	-	-	-
	(pin) ALUMINIUM Ø 40-41	-	-	31 8734	-
	CYLINDER+HEAD CAST-IRON Ø 47	-	-	€ 117,23 Ø 47 (12)	-
	CYLINDER CAST-IRON Ø 47-57,5	-	31 6998	31 7748	31 6405
	for ORIGINAL HEAD ALUM. Ø 47>57,5	-	€ 104,07 Ø 47 (12)	€ 104,07 Ø 47 (12)	€ 95,21 Ø 47 (10)
	HEAD HTSR	-	38 9610	38 7757	38 7157
	for Malossi CYLINDER	-	€ 33,33 Ø 47	€ 37,45 Ø 47	€ 39,02 Ø 47
	CYLINDER+HEAD MHR Replica ALUMINIUM (pin) Ø 47	-	-	-	-
	CRANKSHAFTS RHQ PIN Ø 10	-	-	-	-
	CRANKSHAFTS RHQ PIN Ø 12	-	-	53 8624	-
		-	-	€ 173,09	-
	RADIAL ROLLER BEARING FOR CRANKSHAFT PG. 473	-	-	-	-
	ELECTRONIC CONTROLLER	-	-	-	55 8132
		-	-	-	€ 50,14
	ELECTRONIC CONTROLLER RPM CONTROL (▲)	-	55 8349	55 8627	55 8675
		-	€ 135,02	€ 130,37	€ 104,38
	MULTIVAR VARIATOR	5111364	51 7117	51 7117	51 7073
		€ 62,83	€ 58,71	€ 58,71	€ 58,71
	X SPECIAL BELT BELT	-	61 8396	61 8396	61 7213
		-	€ 14,68	€ 14,68	€ 13,94
	X K BELT BELT	-	61 7221	61 7221	-
		-	€ 24,41	€ 24,41	-
	HTRoll ROLLERS FOR MULTIVAR	66 9420.KO	66 9823.NO	66 9823.NO	66 9823.MO
		€ 10,00 gr.12	€ 9,50 gr.08	€ 9,50 gr.08	€ 9,50 gr.07
	HTRoll ROLLERS FOR ORIGINAL VARIATOR	66 9823.PO	66 9823.R0	66 9823.O0	66 9823.Q0
		€ 9,50 gr.10	€ 9,50 gr.08,5	€ 9,50 gr.09	€ 9,50 gr.07,5
	VENTILVAR FIXED HALF-PULLEY	-	-	-	-
	VARIABLE-SPEED DRIVE ADJUSTER SPRING FOR VARIATOR PG. 438	-	PG.438	PG.438	PG.438
	TORSION CONTROLLER ANTI-FRICTION FIFTH WHEEL	-	2512828	2512828	2512828
		-	€ 4,45	€ 4,45	€ 4,45
	TORQUE DRIVER MOBILE DRIVEN SPLIT PULLEY	-	61 8317	61 8317	-
		-	€ 95,61	€ 95,61	-
	FLY CLUTCH NOT ADJUSTABLE CLUTCH	-	52 8797	52 8797	-
		-	€ 47,30	€ 47,30	-
	DELTA CLUTCH ADJUSTABLE CLUTCH	-	52 7880	52 7880	-
		-	€ 77,89	€ 77,89	-
	CLUTCH BELL CLUTCH BELL (SMOOTH RING)	-	7711115	7711115	7711115
		-	€ 22,60 Ø 107	€ 22,60 Ø 107	€ 22,60 Ø 107
	WING CLUTCH BELL CLUTCH BELL (FINNED RING)	-	-	-	-
		-	-	-	-
	FLY SYSTEM CLUTCH BELL + NOT ADJUSTABLE CLUTCH	-	5214111	5214111	-
		-	€ 63,00 Ø 107	€ 63,00 Ø 107	-
	DELTA SYSTEM CLUTCH BELL + ADJUSTABLE CLUTCH	-	-	-	-
		-	-	-	-
	SPORT SPRINGS FOR FLY / DELTA CLUTCH	-	29 8746	29 8746	-
		-	€ 14,50	€ 14,50	-
	MHR SPRINGS FOR FLY / DELTA CLUTCH	-	29 8747	29 8747	-
		-	€ 19,40	€ 19,40	-
	SPRINGS Ø INTERNAL CLUTCH BELL 105-107 FOR ORIGINAL CLUTCH	-	29 7454	29 7454	29 7454
		-	€ 16,20 <-1996	€ 16,20 <-1996	€ 16,20 <-1996
	MUELLES Ø INTERNAL CLUTCH BELL 112 FOR ORIGINAL CLUTCH	-	29 9605	29 9605	29 9605
		-	€ 16,20 1997->	€ 16,20 1997->	€ 16,20 1997->

18 - To be assembled EXCLUSIVELY with MALOSSİ EXHAUST SYSTEMS

PG - SPECIFICATIONS on the PAGE indicated in the TITLE of the LINE

HONDA		HUPPER		ITALJET			
VISION MET IN	X8R X X8R S	MONTECARLO 30	DRAGSTER	FORMULA	FORMULA	MILLENNIUM	PISTA 2
		(1E40QMB)		(F.MORINI)	(F.MORINI)		
50 2T	50 2T	50 2T	50 2T	50 2T	50 2T	100 2T	50 2T
-	-	3113865 *18* € 120,74 Ø 40 (12)	31 8556 1 € 161,98 Ø 40 (10)	31 9092 € 214,45 Ø 41 (10)	-	-	31 6901 1 € 120,72 Ø 40 (10)
-	31 9879 € 125,95 Ø 47 (12)	3113066 *18* € 117,81 Ø 47 (12)	31 8284 1 € 152,41 Ø 47 (10)	31 8723 € 123,02 Ø 47 (10)	31 9747 € 186,72 Ø 47 (10)	-	31 7237 1 € 112,27 Ø 47 (10)
31 6405 € 95,21 Ø 47 (10)	31 7748 € 104,07 Ø 47 (12)	3113067 € 97,90 Ø 47 (12)	-	31 7137 € 106,52 Ø 47 (10)	-	3111374 € 167,85 Ø 57,5 (14)	31 6882 € 97,90 Ø 47 (10)
38 7157 € 39,02 Ø 47	38 9833 € 37,45 Ø 47	38 7246 € 37,47 Ø 47	-	38 9041 € 37,47 Ø 47	-	-	3812770 € 37,47 Ø 47
-	-	-	31 8430 1 € 228,06 Ø 47 (10)	-	-	-	31 8501 1 € 201,93 Ø 47 (10)
-	-	-	53 7891 € 175,50	53 8631 € 294,80	53 8631 € 294,80	-	53 7621 € 175,50
-	-	5313587 € 175,50	53 8009 € 175,50	-	-	-	53 8008 € 163,04
-	-	-	PG.473	-	-	-	PG.473
55 8132 € 50,14	-	-	-	-	-	-	-
55 8675 € 104,38	55 8627 € 130,37	-	-	-	-	-	-
51 7073 € 58,71	51 7117 € 58,71	5113363 € 60,00	51 7075 € 58,71	51 7128 € 58,71	51 7128 € 58,71	5111380 € 66,95	51 7075 € 58,71
61 7213 € 13,94	61 9221 € 18,68	61 9832 € 17,04	6112730 € 14,36	61 8780 € 18,68	61 8780 € 18,68	-	6112730 € 14,36
-	61 9463 € 28,02	61 7587 € 28,25	6112729 € 25,23	61 8779 € 31,05	61 8779 € 31,05	6112959 € 28,51	6112729 € 25,23
66 9823.M0 € 9,50 gr.07	66 9823.N0 € 9,50 gr.08	66 9823.L0 gr.06 € 9,50 66 9823.O0 gr.09 € 9,50	66 9823.M0 € 9,50 gr.07	66 9823.M0 € 9,50 gr.07	66 9823.M0 € 9,50 gr.07	66 9420.J0 € 10,00 gr.11	66 9823.M0 € 9,50 gr.07
66 9823.R0 € 9,50 gr.08,5	66 9823.R0 € 9,50 gr.08,5	66 9417.G0 € 7,24 gr.06	66 9417.H0 € 7,24 gr.06,5	66 9999.D0 € 8,50 gr.05,5	66 9999.D0 € 8,50 gr.05,5	66 9417.N0 € 7,24 gr.08,3	66 9417.H0 € 7,24 gr.06,5
-	-	61 7151 € 21,28	61 7152 € 21,71	-	-	-	61 7152 € 21,71
PG.438	PG.438	PG.438	PG.438	PG.438	PG.438	2911388.Y0 *PG* € 10,71	PG.438
2512828 € 4,45	2512828 € 4,45	-	2512827 € 4,45	-	-	2512827 € 4,45	2512827 € 4,45
-	61 8317 € 95,61	61 8312 € 85,57	61 9223 € 85,57	-	-	61 8312 € 85,57	61 8312 € 85,57
-	52 8797 € 47,30	52 8798 € 47,30	52 9450 € 47,30	52 8798 € 47,30	52 8798 € 47,30	52 8798 € 47,30	52 8796 € 53,26
-	52 7880 € 77,89	52 7879 € 77,89	52 9451 € 77,89	52 7879 € 77,89	52 7879 € 77,89	52 7879 € 77,89	52 7643 € 77,89
7711115 € 22,60 Ø 107	7711115 € 22,60 Ø 107	-	7711124 € 22,60 Ø 107	-	-	-	-
-	-	-	7711166 € 33,45 Ø 107	-	-	-	-
-	5214111 € 63,00 Ø 107	-	5214112 € 63,00 Ø 107	-	-	-	-
-	-	-	5214113 € 93,84 Ø 107	-	-	-	-
-	29 8746 € 14,50	29 8746 € 14,50	29 8746 € 14,50	29 8746 € 14,50	29 8746 € 14,50	29 8746 € 14,50	29 8746 € 14,50
-	29 8747 € 19,40	29 8747 € 19,40	29 8747 € 19,40	29 8747 € 19,40	29 8747 € 19,40	29 8747 € 19,40	29 8747 € 19,40
29 7454 € 16,20 <-1996	29 7454 € 16,20 <-1996	2913851 € 15,50	29 7456 € 16,20	29 7456 € 16,20	29 7456 € 16,20	29 7715 € 16,20	29 7456 € 16,20
29 9605 € 16,20 1997->	29 9605 € 16,20 1997->	-	-	-	-	-	-



MALOSSI

Scooter 2T

with ENGINE **HONDA**

SH

SHADOW

SXR

VISION

100 2T



50 2T















50 2T

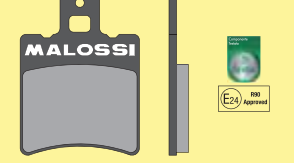
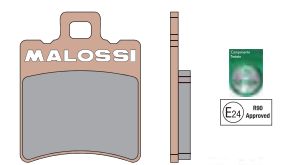

50 2T

**() CHECK "TYPE" SPECIFICATION (HOMOLOGATION MARK)**

	CARBURETTOR		-	-	-	-
	CARBURETTOR KIT Ø 19		-	1610990 € 115,22	1611001 € 112,10	1611004 € 107,15
	CARBURETTOR KIT Ø 21		-	-	-	-
	CARBURETTOR KIT Ø 22		-	-	-	-
	REED VALVE CARBON FIBRE		-	27 7440.C0 € 49,00 VL9	27 7440.C0 € 49,00 VL9	27 7440.C0 € 49,00 VL9
	PETALS SET FOR ORIGINAL REED VALVE		-	27 2728.C0 € 16,27	27 2728.C0 € 16,27	27 1423.C0 € 14,46
	ART OF PERFORMANCE / FLIP HOMOLOGATED  	PG. 426	-	-	-	-
	WILD LION HOMOLOGATED 	PG. 424	-	-	-	-
	RED SPONGE FOR ORIGINAL AIR BOX		1411409 € 4,38	-	-	-
	DOUBLE RED SPONGE FOR ORIGINAL AIR BOX		-	-	-	-
	GEARS HTQ PRIMARY		-	67 9606 € 53,28 z 14/35	67 8700 € 60,44 z 19/37	67 6458 € 65,00 z 16/32
	GEARS HTQ SECONDARY	PG. 478	-	-	-	-
	ROLLER CRANKCASE		-	-	-	-
	BRAKE PADS FRONT		6215042 € 5,72 1997->	-	6215042 € 5,72 1997->	-
	BRAKE PADS MHR FRONT		6215080 € 6,00 1997->	-	6215080 € 6,00 1997->	-
	BRAKE PADS MHR SYNT FRONT		6215007 € 11,96 1997->	-	6215007 € 11,96 1997->	-
	BRAKE PADS REAR		-	-	-	-
	BRAKE PADS MHR REAR		-	-	-	-
	BRAKE PADS MHR SYNT REAR		-	-	-	-
	BRAKE POWER REAR		-	6215802	6215802	6215899 € 20,00
	BRAKE SHOES FRONT		-	€ 18,64	€ 18,64 1997->	6215899 € 20,00
	WHOOP DISC FRONT		-	-	62 9096 € 69,31 1997->	-
	WHOOP DISC REAR		-	-	-	-
	WHOOP DISC REAR		-	-	-	-
	RS1 - RS3 REAR SHOCK ABSORBER		-	46 7906 € 140,92	46 7905 € 140,92	46 7905 € 140,92
	RS24 - RS24/10 FRONT SHOCK ABSORBER		-	-	-	-
	RS24 - RS24/10 - RS24/10-R REAR SHOCK ABSORBER		-	46 7589 € 221,96	46 7588 € 255,97	46 7588 € 255,97
	RS24 FRONT + REAR		-	-	-	-
	HORQUILLA F32S FORK STEMS Ø 32		-	-	-	-
	HORQUILLA F37R MHR FORK STEMS Ø 37		-	-	-	-

19 - for the ASSEMBLY MODIFY the CRANKCASE

67 - TO COUPLE ONLY with MALOSSİ CYLINDERS: 3216986 € 122,00



MALOSSI

Scooter 2T

with ENGINE 

ITALJET

SCOOP

TORPEDO

TORPEDO NEW

VELOCIFERO

50 2T



50 2T



50 2T



50 2T

**(▲) ATTENTION: ONLY FOR vehicles WITHOUT IMMOBILIZER KEY**

	CYLINDER+HEAD CAST-IRON Ø 40	31 6901	1	31 9092	31 8520	31 9092			
	(pin) ALUMINIUM Ø 40-41	€120,72	Ø 40 (10)	€214,45	Ø 41 (10)	€124,91	Ø 40 (12)	€214,45	Ø 41 (10)
	CYLINDER+HEAD CAST-IRON Ø 47	31 7237	1	31 8723	31 6926	31 8723			
	(pin) ALUMINIUM Ø 47-57,5	€112,27	Ø 47 (10)	€123,02	Ø 47 (10)	€120,25	Ø 47 (12)	€123,02	Ø 47 (10)
	CYLINDER CAST-IRON Ø 47-57,5	31 6882		31 7137	31 6915	31 7137			
	for ORIGINAL HEAD ALUM. Ø 47>57,5	€97,90	Ø 47 (10)	€106,52	Ø 47 (10)	€100,86	Ø 47 (12)	€106,52	Ø 47 (10)
	HEAD HTSR	3812770		38 9041	38 7118	38 9041			
	for Malossi CYLINDER	€37,47	Ø 47	€37,47	Ø 47	€37,45	Ø 47	€37,47	Ø 47
	CYLINDER+HEAD MHR Replica ALUMINIUM	31 8501	1	-	31 8463	-			
	(pin) Ø 47	€201,93	Ø 47 (10)	-	€207,00	Ø 47 (12)	-	-	-
	CRANKSHAFTS RHQ	53 7621		53 8631	-	53 8631			
	PIN Ø 10	€175,50		€294,80		€294,80			
	CRANKSHAFTS RHQ	53 8008		-	53 7600	-			
	PIN Ø 12	€163,04		-	€175,50				
	RADIAL ROLLER BEARING								
	FOR CRANKSHAFT	PG. 473		PG.473					
	ELECTRONIC CONTROLLER	-		-	5513195	*35*			
		-		-	€92,82		-	-	-
	ELECTRONIC CONTROLLER	-		-	5513196	*35*			
	RPM CONTROL	-		-	€140,51		-	-	-
	MULTIVAR	51 7075		51 7128	51 9019	51 7128			
	VARIATOR	€58,71		€58,71	€61,80	€58,71			
	X SPECIAL BELT	6112730		-	61 9830	-			
	BELT	€14,36		-	€17,34				
	X K BELT	6112729		61 7231	61 9535	61 7231			
	BELT	€25,23		€23,22	€28,72	€23,22			
	HTRoll	66 9823.M0		66 9823.M0	66 9420.M0	66 9823.M0			
	ROLLERS FOR MULTIVAR	€9,50	gr.07	€9,50	gr.07	€10,00	gr.07,2	€9,50	gr.07
	HTRoll	66 9417.H0		66 9417.H0	66 9420.N0	66 9999.E0			
	ROLLERS FOR ORIGINAL VARIATOR	€7,24	gr.06,5	€7,24	gr.06,5	€10,00	gr.07,5	€8,50	gr.06
	VENTILVAR	61 7152		-	-	-			
	FIXED HALF-PULLEY	€21,71		-	-	-			
	VARIABLE-SPEED DRIVE ADJUSTER SPRING								
	FOR VARIATOR	PG. 438		PG.438		PG.438			
	TORSION CONTROLLER	2512827		-	2512828	-			
	ANTIFRICTION FIFTH WHEEL	€4,45		-	€4,45		-	-	-
	TORQUE DRIVER	61 8312		-	61 9100	-			
	MOBILE DRIVEN SPLIT PULLEY	€85,57		-	€85,57		-	-	-
	FLY CLUTCH	52 8796		52 8798	52 8797	52 8798			
	NOT ADJUSTABLE CLUTCH	€53,26		€47,30	€47,30	€47,30			
	DELTA CLUTCH	52 7643		52 7879	52 7880	52 7879			
	ADJUSTABLE CLUTCH	€77,89		€77,89	€77,89	€77,89			
	CLUTCH BELL	-		-	7711115	-			
	CLUTCH BELL (SMOOTH RING)	-		-	€22,60	Ø 107	-	-	-
	WING CLUTCH BELL	-		-	7711207	-			
	CLUTCH BELL (FINNED RING)	-		-	€33,45	Ø 107	-	-	-
	FLY SYSTEM	-		-	5214111	-			
	CLUTCH BELL + NOT ADJUSTABLE CLUTCH	-		-	€63,00	Ø 107	-	-	-
	DELTA SYSTEM	-		-	5214110	-			
	CLUTCH BELL + ADJUSTABLE CLUTCH	-		-	€93,84	Ø 107	-	-	-
	SPORT SPRINGS	29 8746		29 8746	29 8746	29 8746			
	FOR FLY / DELTA CLUTCH	€14,50		€14,50	€14,50	€14,50			
	MHR SPRINGS	29 8747		29 8747	29 8747	29 8747			
	FOR FLY / DELTA CLUTCH	€19,40		€19,40	€19,40	€19,40			
	SPRINGS Ø INTERNAL CLUTCH BELL 105-107	29 7456		29 7456	-	29 7456			
	FOR ORIGINAL CLUTCH	€16,20		€16,20	-	€16,20			
	MUELLES Ø INTERNAL CLUTCH BELL 112	-		-	-	-			
	FOR ORIGINAL CLUTCH	-		-	-	-			

18 - To be assembled EXCLUSIVELY with MALOSSI EXHAUST SYSTEMS

35 - IT CAN BE ASSEMBLED WITH NO MODIFICATION to the original system, EVEN ON vehicles PRODUCED 2001->

ITALJET		KEEWAY						KYMCO
YANKEE	F-ACT	GOCCIA	HURRICANE euro 2	MATRIX	PIXEL euro 2	RY8	AGILITY R16 euro 2	
		(KW1E40QMB-4)	(KW1E40QMB)	(KW1E40QMB-4)	(KW1E40QMB)	(KW1E40QMB-4)	(KF10B)	
50 2T	50 2T	50 2T	50 2T	50 2T	50 2T	50 2T	50 2T	
31 6901 1 €120,72 Ø 40 (10)	3113865 *18* €120,74 Ø 40 (12)	3113865 *18* €120,74 Ø 40 (12)	3113865 *18* €120,74 Ø 40 (12)	3113865 *18* €120,74 Ø 40 (12)	3113865 *18* €120,74 Ø 40 (12)	3113865 *18* €120,74 Ø 40 (12)	-	
31 7237 1 €112,27 Ø 47 (10)	3113066 *18* €117,81 Ø 47 (12)	3113066 *18* €117,81 Ø 47 (12)	3113066 *18* €117,81 Ø 47 (12)	3113066 *18* €117,81 Ø 47 (12)	3113066 *18* €117,81 Ø 47 (12)	3113066 *18* €117,81 Ø 47 (12)	31 9987 €130,44 Ø 47 (12)	
31 6882 €97,90 Ø 47 (10)	3113067 €97,90 Ø 47 (12)	3113067 €97,90 Ø 47 (12)	3113067 €97,90 Ø 47 (12)	3113067 €97,90 Ø 47 (12)	3113067 €97,90 Ø 47 (12)	3113067 €97,90 Ø 47 (12)	-	
3812770 €37,47 Ø 47	38 7246 €37,47 Ø 47	38 7246 €37,47 Ø 47	38 7246 €37,47 Ø 47	38 7246 €37,47 Ø 47	38 7246 €37,47 Ø 47	38 7246 €37,47 Ø 47	38 7246 €37,47 Ø 47	
31 8501 1 €201,93 Ø 47 (10)	-	-	-	-	-	-	-	
53 7621 €175,50	-	-	-	-	-	-	-	
53 8008 €163,04	5313587 €175,50	5313587 €175,50	5313587 €175,50	5313587 €175,50	5313587 €175,50	5313587 €175,50	-	
PG.473	-	-	-	-	-	-	-	
-	-	-	-	-	-	-	-	
-	-	-	-	-	-	-	-	
51 7075 €58,71	5113363 €60,00	5113363 €60,00	5113363 €60,00	5113363 €60,00	5113363 €60,00	5113363 €60,00	51 9988 €58,71	
6112730 €14,36	61 9832 €17,04	61 9832 €17,04	61 9832 €17,04	61 9832 €17,04	61 9832 €17,04	61 9832 €17,04	-	
6112729 €25,23	61 7587 €28,25	61 7587 €28,25	61 7587 €28,25	61 7587 €28,25	61 7587 €28,25	61 7587 €28,25	6113501 €20,40	
66 9823.MO €9,50 gr.07	66 9823.LO gr.06 €9,50 66 9823.OO gr.09 €9,50	66 9823.LO gr.06 €9,50 66 9823.OO gr.09 €9,50	66 9823.LO gr.06 €9,50 66 9823.OO gr.09 €9,50	66 9823.LO gr.06 €9,50 66 9823.OO gr.09 €9,50	66 9823.LO gr.06 €9,50 66 9823.OO gr.09 €9,50	66 9823.LO gr.06 €9,50 66 9823.OO gr.09 €9,50	66 9823.OO €9,50 gr.09	
66 9417.HO €7,24 gr.06,5	66 9417.E0 €7,24 gr.04,8	66 9417.G0 €7,24 gr.06	66 9417.E0 €7,24 gr.04,8	66 9417.E0 €7,24 gr.04,8	66 9417.E0 €7,24 gr.04,8	66 9417.E0 €7,24 gr.04,8	66 9417.G0 €7,24 gr.06	
61 7152 €21,71	61 7151 €21,28	61 7151 €21,28	61 7151 €21,28	61 7151 €21,28	61 7151 €21,28	61 7151 €21,28	-	
PG.438	PG.438	PG.438	PG.438	PG.438	PG.438	PG.438	PG.438	
2512827 €4,45	-	-	-	-	-	-	2512828 €4,45	
61 8312 €85,57	61 8312 €85,57	61 8312 €85,57	61 8312 €85,57	61 8312 €85,57	61 8312 €85,57	61 8312 €85,57	61 8317 €95,61	
52 8796 €53,26	52 8798 €47,30	52 8798 €47,30	52 8798 €47,30	52 8798 €47,30	52 8798 €47,30	52 8798 €47,30	52 8797 €47,30	
52 7643 €77,89	52 7879 €77,89	52 7879 €77,89	52 7879 €77,89	52 7879 €77,89	52 7879 €77,89	52 7879 €77,89	52 7880 €77,89	
-	-	-	-	-	-	-	7711115 €22,60 Ø 107	
-	-	-	-	-	-	-	7711207 €33,45 Ø 107	
-	-	-	-	-	-	-	5214111 €63,00 Ø 107	
-	-	-	-	-	-	-	5214110 €93,84 Ø 107	
29 8746 €14,50	29 8746 €14,50	29 8746 €14,50	29 8746 €14,50	29 8746 €14,50	29 8746 €14,50	29 8746 €14,50	29 8746 €14,50	
29 8747 €19,40	29 8747 €19,40	29 8747 €19,40	29 8747 €19,40	29 8747 €19,40	29 8747 €19,40	29 8747 €19,40	29 8747 €19,40	
29 7456 €16,20	29 7715 €16,20	29 7715 €16,20	29 7715 €16,20	29 7715 €16,20	29 7715 €16,20	29 7715 €16,20	29 9605 €16,20	
-	-	-	-	-	-	-	-	



MALOSSI

Scooter 2T

with ENGINE 

ITALJET

SCOOP

TORPEDO

TORPEDO NEW

VELOCIFERO

50 2T



50 2T

















50 2T

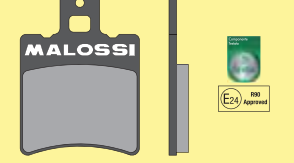
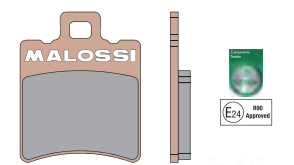

50 2T



CHECK "TYPE" SPECIFICATION (HOMOLOGATION MARK)		50 2T	50 2T	50 2T	50 2T
	CARBURETTOR	-	-	72 7084 € 75,17 Ø 17,5	-
	CARBURETTOR KIT Ø 19	-	-	1611042 € 118,04	-
	CARBURETTOR KIT Ø 21	-	1611014 € 170,33	1610995 € 114,23	1611014 € 170,33
	CARBURETTOR KIT Ø 22	-	-	1611029 € 96,77	-
	REED VALVE CARBON FIBRE	27 7441.C0 € 46,02 VL10	-	27 7708.C0 € 48,95 VL11	-
	PETALS SET FOR ORIGINAL REED VALVE	27 3549.C0 € 16,19	-	27 7054.C0 € 18,71	27 2728.C0 € 16,27
	ART OF PERFORMANCE / FLIP HOMOLOGATED    PG. 426	-	-	-	-
	WILD LION HOMOLOGATED  PG. 424	-	-	-	-
	RED SPONGE FOR ORIGINAL AIR BOX	-	-	-	-
	DOUBLE RED SPONGE FOR ORIGINAL AIR BOX	-	-	-	-
	GEARS HTQ PRIMARY	67 3677 € 57,67 z 16/40	67 7149 € 53,80 z 14/34	-	67 7149 € 53,80 z 14/34
	GEARS HTQ SECONDARY PG. 478	-	-	6711135 € 58,86 z 15/55	-
	ROLLER CRANKCASE	-	-	2514521 *66* € 95,00	-
	BRAKE PADS FRONT	6215044 € 6,97 1993->	6215051 € 5,72 1997->	-	-
	BRAKE PADS MHR FRONT	62 9084 € 6,90 1993->	6215076 € 6,24 1997->	-	-
	BRAKE PADS MHR SYNT FRONT	-	6215005 € 11,96 1997->	-	-
	BRAKE PADS REAR	-	-	-	-
	BRAKE PADS MHR REAR	-	-	-	-
	BRAKE PADS MHR SYNT REAR	-	-	-	-
	BRAKE POWER REAR	6215834	-	-	-
	BRAKE SHOES FRONT	€ 21,50 1993->	-	-	-
	WHOO P DISC FRONT	-	-	-	-
	WHOO P DISC REAR	-	-	-	-
	RS1 - RS3 REAR SHOCK ABSORBER	-	46 7905 € 140,92	-	46 7905 € 140,92
	RS24 - RS24/10 FRONT SHOCK ABSORBER	-	-	-	-
	RS24 - RS24/10 - RS24/10-R REAR SHOCK ABSORBER	-	46 7588 € 255,97	-	46 7588 € 255,97
	RS24 FRONT + REAR	-	-	-	-
	HORQUILLA F32S FORK STEMS Ø 32	-	-	-	-
	HORQUILLA F37R MHR FORK STEMS Ø 37	-	-	-	-

19 - for the ASSEMBLY MODIFY the CRANKCASE

66 - NOT to be used on VEHICLE WITH ORIGINAL PRIMARY GEARS

ITALJET		KEEWAY						KYMCO
YANKEE	F-ACT	GOCCIA	HURRICANE euro 2	MATRIX	PIXEL euro 2	RY8	AGILITY R16 euro 2	
		(KW1E40QMB-4)	(KW1E40QMB)	(KW1E40QMB-4)	(KW1E40QMB)	(KW1E40QMB-4)	(KF10B)	
50 2T	50 2T	50 2T	50 2T	50 2T	50 2T	50 2T	50 2T	
-	72 9215 € 78,76 Ø 17,5	72 9215 € 78,76 Ø 17,5	72 9215 € 78,76 Ø 17,5	72 9215 € 78,76 Ø 17,5	72 9215 € 78,76 Ø 17,5	72 9215 € 78,76 Ø 17,5	-	
-	1611042 € 118,04	1611042 € 118,04	1611042 € 118,04	1611042 € 118,04	1611042 € 118,04	1611042 € 118,04	1611028 € 121,39	
-	1610995 € 114,23	1610995 € 114,23	1610995 € 114,23	1610995 € 114,23	1610995 € 114,23	1610995 € 114,23	-	
-	-	-	-	-	-	-	-	
27 7441.C0 € 46,02 VL10	27 7731.C0 *19* € 48,95 VL12	27 7731.C0 *19* € 48,95 VL12	27 7731.C0 *19* € 48,95 VL12	27 7731.C0 *19* € 48,95 VL12	27 7731.C0 *19* € 48,95 VL12	27 7731.C0 *19* € 48,95 VL12	-	
27 3549.C0 € 16,19	27 7054.C0 € 18,71	27 7054.C0 € 18,71	27 7054.C0 € 18,71	27 7054.C0 € 18,71	27 7054.C0 € 18,71	27 7054.C0 € 18,71	-	
-	-	-	-	-	-	-	-	
-	-	-	-	-	-	-	3216593 € 95,00	
-	1414044 € 3,56	1414044 € 3,56	1414044 € 3,56	1414044 € 3,56	1414044 € 3,56	1414044 € 3,56	-	
-	1414483 € 5,30	1414483 € 5,30	1414483 € 5,30	1414483 € 5,30	1414483 € 5,30	1414483 € 5,30	-	
67 3677 € 57,67 z 16/40	6713602 € 67,32 z 14/42	6713602 € 67,32 z 14/42	67 7014 € 68,44 z 15/41	6713602 € 67,32 z 14/42	67 7014 € 68,44 z 15/41	6713602 € 67,32 z 14/42	-	
-	-	-	-	-	-	-	-	
-	-	-	-	-	-	-	-	
-	-	6215042 € 5,72	-	-	6215059 € 8,84	-	6215858 € 8,84 2010->	
-	-	6215080 € 6,00	-	-	6212164 € 8,50	-	-	
-	-	6215007 € 11,96	-	-	-	-	-	
-	-	-	-	-	-	6215857 € 8,84 2010->	-	
-	-	-	-	-	-	-	-	
-	-	-	-	-	-	-	-	
6215834 € 21,50	-	-	-	-	-	-	-	
-	-	-	-	-	62 9096 € 69,31	6212603 € 72,56	-	
-	-	-	-	-	-	-	-	
4615434 € 88,74	46 7905 € 140,92	46 7906 € 140,92	46 7905 € 140,92	46 7905 € 140,92	4615434 € 88,74	4615433 € 90,78 46 8610 € 141,25	-	
-	-	-	-	-	-	-	-	
46 7591 € 230,79	46 7588 € 255,97	46 7589 € 221,96	46 7588 € 255,97	46 7588 € 255,97	46 7591 € 230,79	46 8611 € 219,76	-	
-	-	-	-	-	-	-	-	
-	-	-	-	-	-	-	-	
-	-	-	-	-	-	-	-	



MALOSSI

Scooter 2T

with ENGINE **KYMCO**

CX

DINK

DINK

DJ X

50 2T



50 2T



50 2T

LC

50 2T

**(▲) ATTENTION: ONLY FOR vehicles WITHOUT IMMOBILIZER KEY**

	CYLINDER+HEAD CAST-IRON Ø 40 (pin) ALUMINIUM Ø 40-41	-	-	-	-
	CYLINDER+HEAD (pin) CAST-IRON Ø 47	-	31 9987 € 130,44 Ø 47 (12)	3111667 € 181,12 Ø 47 (12)	-
	CYLINDER CAST-IRON Ø 47-57,5 for ORIGINAL HEAD ALUM. Ø 47>57,5	-	-	-	31 6405 € 95,21 Ø 47 (10)
	HEAD HTSR for Malossi CYLINDER	-	38 7246 € 37,47 Ø 47	-	-
	CYLINDER+HEAD MHR Replica ALUMINIUM (pin) Ø 47	31 8473 € 217,30 Ø 47 (12)	-	-	31 8473 € 217,30 Ø 47 (12)
	CRANKSHAFTS RHQ PIN Ø 10	-	-	-	-
	CRANKSHAFTS RHQ PIN Ø 12	-	-	-	-
	RADIAL ROLLER BEARING FOR CRANKSHAFT	-	-	-	-
	ELECTRONIC CONTROLLER	-	-	-	-
	ELECTRONIC CONTROLLER RPM CONTROL	-	-	-	-
	MULTIVAR VARIATOR	51 7484 € 58,71	51 9988 € 58,71	51 9988 € 58,71	51 7072 € 58,71
	X SPECIAL BELT BELT	-	-	-	-
	X K BELT BELT	-	6111153 € 28,25	6111153 € 28,25	61 7211 € 25,68
	HTRoll ROLLERS FOR MULTIVAR	66 9823.M0 € 9,50 gr.07	66 9823.O0 € 9,50 gr.09	66 9823.O0 € 9,50 gr.09	66 9823.M0 € 9,50 gr.07
	HTRoll ROLLERS FOR ORIGINAL VARIATOR	66 9823.R0 € 9,50 gr.08,5	66 9823.R0 € 9,50 gr.08,5	-	66 9823.R0 € 9,50 gr.08,5
	VENTILVAR FIXED HALF-PULLEY	-	-	-	-
	VARIABLE-SPEED DRIVE ADJUSTER SPRING FOR VARIATOR	PG. 438 PG.438	PG.438	-	PG.438
	TORSION CONTROLLER ANTIFRICTION FIFTH WHEEL	2512828 € 4,45	2512828 € 4,45	2512828 € 4,45	2512828 € 4,45
	TORQUE DRIVER MOBILE DRIVEN SPLIT PULLEY	61 8317 € 95,61	61 8317 € 95,61	61 8317 € 95,61	-
	FLY CLUTCH NOT ADJUSTABLE CLUTCH	-	52 8797 € 47,30	52 8797 € 47,30	52 8797 € 47,30
	DELTA CLUTCH ADJUSTABLE CLUTCH	-	52 7880 € 77,89	52 7880 € 77,89	52 7880 € 77,89
	CLUTCH BELL CLUTCH BELL (SMOOTH RING)	7711115 € 22,60 Ø 107	7711115 € 22,60 Ø 107	7711115 € 22,60 Ø 107	7711115 € 22,60 Ø 107
	WING CLUTCH BELL CLUTCH BELL (FINNED RING)	7711207 € 33,45 Ø 107	7711207 € 33,45 Ø 107	7711207 € 33,45 Ø 107	7711207 € 33,45 Ø 107
	FLY SYSTEM CLUTCH BELL + NOT ADJUSTABLE CLUTCH	-	5214111 € 63,00 Ø 107	5214111 € 63,00 Ø 107	5214111 € 63,00 Ø 107
	DELTA SYSTEM CLUTCH BELL + ADJUSTABLE CLUTCH	-	5214110 € 93,84 Ø 107	5214110 € 93,84 Ø 107	5214110 € 93,84 Ø 107
	SPORT SPRINGS FOR FLY / DELTA CLUTCH	-	29 8746 € 14,50	29 8746 € 14,50	29 8746 € 14,50
	MHR SPRINGS FOR FLY / DELTA CLUTCH	-	29 8747 € 19,40	29 8747 € 19,40	29 8747 € 19,40
	SPRINGS Ø INTERNAL CLUTCH BELL 105-107 FOR ORIGINAL CLUTCH	29 7454 € 16,20 <-1996	29 7454 € 16,20 <-1996	-	29 7454 € 16,20 <-1996
	MUELLES Ø INTERNAL CLUTCH BELL 112 FOR ORIGINAL CLUTCH	29 9605 € 16,20 1997->	29 9605 € 16,20 1997->	-	29 9605 € 16,20 1997->

27 - For vehicles with YAMAHA FLYWHEEL

32 - For vehicles with YAMAHA FLYWHEEL - If it is a DUCATI : TC UNIT K15 +BOBINA / RPM CONTROL 55 8765 € 127,73

KYMCO							MALAGUTI
DJ Y	HEROISM	K 12	PEOPLE	SNIPER	SUPER 9	TOP BOY - COBRA	CENTRO
50 2T	50 2T	50 2T	50 2T	50 2T	50 2T	50 2T	50 2T
-	-	-	-	-	-	-	31 8562 €120,74 Ø 40 (10)
31 7200 €123,02 Ø 47 (12)	-	31 7200 €123,02 Ø 47 (12)	31 9987 €130,44 Ø 47 (12)	-	3111667 €181,12 Ø 47 (12)	31 9987 €130,44 Ø 47 (12)	31 7083 €114,25 Ø 47 (10)
31 6998 €104,07 Ø 47 (12)	31 8091 €128,21 Ø 47 (12)	31 6998 €104,07 Ø 47 (12)	-	31 8091 €128,21 Ø 47 (12)	-	-	31 7002 €97,90 Ø 47 (10)
38 7007 €37,45 Ø 47	-	38 7007 €37,45 Ø 47	38 7246 €37,47 Ø 47	-	-	38 7246 €37,47 Ø 47	38 7246 €37,47 Ø 47
31 8473 €217,30 Ø 47 (12)	-	-	-	-	-	-	31 8437 €207,00 Ø 47 (10)
-	-	-	-	-	-	-	53 7891 €175,50
53 7604 €185,00	-	-	-	-	-	-	53 8009 €175,50
-	-	-	-	-	-	-	PG.473
-	-	-	-	-	-	-	55 8133 *27* €50,14
-	-	-	-	-	-	-	55 8676 *32* €97,59
51 7484 €58,71	51 7484 €58,71	51 9988 €58,71	51 9988 €58,71	51 7484 €58,71	51 9988 €58,71	51 9988 €58,71	51 7075 €58,71
-	-	-	-	-	-	-	6112730 €14,36
-	-	-	6111153 €28,25	-	6111153 €28,25	6111153 €28,25	6112729 €25,23
66 9823.M0 €9,50 gr.07	66 9823.M0 €9,50 gr.07	66 9823.O0 €9,50 gr.09	66 9823.O0 €9,50 gr.09	66 9823.M0 €9,50 gr.07	66 9823.O0 €9,50 gr.09	66 9823.O0 €9,50 gr.09	66 9823.M0 €9,50 gr.07
66 9823.R0 €9,50 gr.08,5	66 9823.R0 €9,50 gr.08,5	66 9823.R0 €9,50 gr.08,5	66 9823.R0 €9,50 gr.08,5	66 9823.Q0 €9,50 gr.07,5	66 9823.R0 €9,50 gr.08,5	66 9823.R0 €9,50 gr.08,5	66 9417.10 €7,24 gr.06,8
-	-	-	-	-	-	-	61 7152 €21,71
PG.438	PG.438	PG.438	PG.438	PG.438	PG.438	PG.438	PG.438
2512828 €4,45	2512828 €4,45	2512828 €4,45	2512828 €4,45	2512828 €4,45	2512828 €4,45	2512828 €4,45	2512827 €4,45
61 8317 €95,61	-	-	61 8317 €95,61	61 8317 €95,61	61 8317 €95,61	61 8317 €95,61	61 8312 Ø 33 € 85,57 61 9223 Ø 34 € 85,57
52 8797 €47,30	52 8797 €47,30	-	52 8797 €47,30	52 8797 €47,30	52 8797 €47,30	52 8797 €47,30	52 8796 Ø 105 € 53,26 52 9450 Ø 107 € 47,30
52 7880 €77,89	52 7880 €77,89	-	52 7880 €77,89	52 7880 €77,89	52 7880 €77,89	52 7880 €77,89	52 7643 Ø 105 € 77,89 52 9451 Ø 107 € 77,89
7711115 €22,60 Ø 107	7711115 €22,60 Ø 107	7711115 €22,60 Ø 107	7711115 €22,60 Ø 107	7711115 €22,60 Ø 107	7711115 €22,60 Ø 107	7711115 €22,60 Ø 107	7711124 €22,60 Ø 107
7711207 €33,45 Ø 107	7711207 €33,45 Ø 107	7711207 €33,45 Ø 107	7711207 €33,45 Ø 107	7711207 €33,45 Ø 107	7711207 €33,45 Ø 107	7711207 €33,45 Ø 107	7711166 €33,45 Ø 107
5214111 €63,00 Ø 107	5214111 €63,00 Ø 107	-	5214111 €63,00 Ø 107	5214111 €63,00 Ø 107	5214111 €63,00 Ø 107	5214111 €63,00 Ø 107	5214112 €63,00 Ø 107
5214110 €93,84 Ø 107	5214110 €93,84 Ø 107	-	5214110 €93,84 Ø 107	5214110 €93,84 Ø 107	5214110 €93,84 Ø 107	5214110 €93,84 Ø 107	5214113 €93,84 Ø 107
29 8746 €14,50	29 8746 €14,50	-	29 8746 €14,50	29 8746 €14,50	29 8746 €14,50	29 8746 €14,50	29 8746 €14,50
29 8747 €19,40	29 8747 €19,40	-	29 8747 €19,40	29 8747 €19,40	29 8747 €19,40	29 8747 €19,40	29 8747 €19,40
29 7454 €16,20 <-1996	29 7454 €16,20 <-1996	29 7454 €16,20 <-1996	29 9605 €16,20	29 7454 €16,20 <-1996	29 9605 €16,20	29 9605 €16,20	29 7714 €13,80 Ø 105
29 9605 €16,20 1997->	29 9605 €16,20 1997->	29 9605 €16,20 1997->	-	29 9605 €16,20 1997->	-	-	29 9605 €16,20 Ø 107



MALOSS

Scooter 2T

with ENGINE 

KYMCO

CX

DINK

DINK

DJ X

50 2T



50 2T



















50 2T

LC

50 2T



CHECK "TYPE" SPECIFICATION (HOMOLOGATION MARK)		50 2T		50 2T		50 2T	LC	50 2T	
	CARBURETTOR		-	-	-	-	-	-	-
	CARBURETTOR KIT Ø 19		-	1611028 € 121,39	1611028 € 121,39	1610991 € 100,64			
	CARBURETTOR KIT Ø 21		-	-	-	-			
	CARBURETTOR KIT Ø 22		-	-	-	-			
	REED VALVE CARBON FIBRE		-	-	-	27 7440.C0 € 49,00	VL9		
	PETALS SET FOR ORIGINAL REED VALVE		-	-	27 7054.C0 € 18,71	27 2728.C0 € 16,27			
	ART OF PERFORMANCE / FLIP HOMOLOGATED  	PG. 426	-	-	-	-			
	WILD LION HOMOLOGATED 	PG. 424	-	3216593 € 95,00	-	-			
	RED SPONGE FOR ORIGINAL AIR BOX		-	-	-	-			
	DOUBLE RED SPONGE FOR ORIGINAL AIR BOX		-	-	-	-			
	GEARS HTQ PRIMARY		67 6458 € 65,00	-	-	-	67 6458 € 65,00	z 16/32	z 16/32
	GEARS HTQ SECONDARY	PG. 478	-	-	-	-			
	ROLLER CRANKCASE		-	-	-	-			
	SCREEN		-	-	-	-			
	BRAKE PADS FRONT		6215065 € 10,40	6215055 € 8,84	-	-			
	BRAKE PADS MHR FRONT		62 9086 € 10,17	6215078 € 8,84	-	-			
	BRAKE PADS MHR SYNT FRONT		-	-	-	-			
	BRAKE PADS REAR		-	-	-	-			
	BRAKE PADS MHR REAR		-	-	-	-			
	BRAKE PADS MHR SYNT REAR		-	-	-	-			
	BRAKE POWER REAR		-	6215802 € 18,64	-	6215899 € 20,00			
	BRAKE SHOES FRONT		-	-	-	-			
	WHOOPIE DISC FRONT		62 8960 € 60,68	-	-	-			
	WHOOPIE DISC REAR		-	-	-	-			
	RS1 - RS3 REAR SHOCK ABSORBER		-	-	-	46 7905 € 140,92	RS3		
	RS24 - RS24/10 FRONT SHOCK ABSORBER		-	-	-	-			
	RS24 - RS24/10 - RS24/10-R REAR SHOCK ABSORBER		-	-	-	46 7588 € 255,97	RS24		
	RS24 FRONT + REAR		-	-	-	-			
	HORQUILLA F32S FORK STEMS Ø 32		-	-	-	-			
	HORQUILLA F37R MHR FORK STEMS Ø 37		-	-	-	-			



MALOSSI

Scooter 2T

with ENGINE 

MALAGUTI

CIAK

CIAK

CROSSER CR1

F10

(▲) ATTENTION: ONLY FOR vehicles WITHOUT IMMOBILIZER KEY

		50 2T	100 2T	50 2T	50 2T
	CYLINDER+HEAD CAST-IRON Ø 40	31 8562 1	-	31 9092	31 8562 1
	(pin) ALUMINIUM Ø 40-41	€120,74 Ø 40 (10)		€214,45 Ø 41 (10)	€120,74 Ø 40 (10)
	CYLINDER+HEAD	31 7083 1	-	31 8723	31 7083 1
	(pin) CAST-IRON Ø 47	€114,25 Ø 47 (10)		€123,02 Ø 47 (10)	€114,25 Ø 47 (10)
	CYLINDER CAST-IRON Ø 47-57,5	31 7002	-	31 7137	31 7002
	for ORIGINAL HEAD ALUM. Ø 47>57,5	€97,90 Ø 47 (10)		€106,52 Ø 47 (10)	€97,90 Ø 47 (10)
	HEAD HTSR	38 7246	-	38 9041	38 7246
	for Malossi CYLINDER	€37,47 Ø 47		€37,47 Ø 47	€37,47 Ø 47
	CYLINDER+HEAD MHR Replica ALUMINIUM	31 8437 1	-	-	31 8437 1
	(pin) Ø 47	€207,00 Ø 47 (10)			€207,00 Ø 47 (10)
	CRANKSHAFTS RHQ	53 7891	-	53 8631	53 7891
	PIN Ø 10	€175,50		€294,80	€175,50
	CRANKSHAFTS RHQ	53 8009	-	-	53 8009
	PIN Ø 12	€175,50			€175,50
	RADIAL ROLLER BEARING		-	-	
FOR CRANKSHAFT	PG. 473	PG.473			PG.473
	ELECTRONIC CONTROLLER	55 8133 *27*	-	-	55 8133 *27*
		€50,14			€50,14
	ELECTRONIC CONTROLLER	55 8676 *32*	-	-	55 8676 *32*
	RPM CONTROL	€97,59			€97,59
	MULTIVAR	51 7075	5111327	51 7128	51 7075 *PG*
	VARIATOR	€58,71	€58,71	€58,71	€58,71
	X SPECIAL BELT	6112730	-	61 8780	6112741
	BELT	€14,36		€18,68	€15,25
	X K BELT	6112729	61 8779	61 8779	6112742
	BELT	€25,23	€31,05	€31,05	€26,33
	HTRoll	66 9823.M0	66 9823.O0	66 9823.M0	66 9823.M0
	ROLLERS FOR MULTIVAR	€9,50 gr.07	€9,50 gr.09	€9,50 gr.07	€9,50 gr.07
	HTRoll	-	66 9999.F0	66 9999.D0	66 9417.H0
	ROLLERS FOR ORIGINAL VARIATOR		€8,50 gr.06,5	€8,50 gr.05,5	€7,24 gr.06,5
	VENTILVAR	61 7152	-	-	61 7152
	FIXED HALF-PULLEY	€21,71			€21,71
	VARIABLE-SPEED DRIVE ADJUSTER SPRING		-		
	FOR VARIATOR	PG. 438	PG.438	PG.438	PG.438
	TORSION CONTROLLER	2512827	-	-	2512827
	ANTIFRICTION FIFTH WHEEL	€4,45			€4,45
	TORQUE DRIVER	61 8312 Ø 33 €85,57	-	-	61 8312 Ø 33 €85,57
	MOBILE DRIVEN SPLIT PULLEY	61 9223 Ø 34 €85,57			61 9223 Ø 34 €85,57
	FLY CLUTCH	52 9450	52 8798	52 8798	52 8796 Ø 105 €53,26
	NOT ADJUSTABLE CLUTCH	€47,30	€47,30	€47,30	52 9450 Ø 107 €47,30
	DELTA CLUTCH	52 9451	52 7879	52 7879	52 7643 Ø 105 €77,89
	ADJUSTABLE CLUTCH	€77,89	€77,89	€77,89	52 9451 Ø 107 €77,89
	CLUTCH BELL	7711124	-	-	7711124
	CLUTCH BELL (SMOOTH RING)	€22,60 Ø 107			€22,60 Ø 107
	WING CLUTCH BELL	7711166	-	-	7711166
	CLUTCH BELL (FINNED RING)	€33,45 Ø 107			€33,45 Ø 107
	FLY SYSTEM	5214112	-	-	5214112
	CLUTCH BELL + NOT ADJUSTABLE CLUTCH	€63,00 Ø 107			€63,00 Ø 107
	DELTA SYSTEM	5214113	-	-	5214113
	CLUTCH BELL + ADJUSTABLE CLUTCH	€93,84 Ø 107			€93,84 Ø 107
	SPORT SPRINGS	29 8746	29 8746	29 8746	29 8746
	FOR FLY / DELTA CLUTCH	€14,50	€14,50	€14,50	€14,50
	MHR SPRINGS	29 8747	29 8747	29 8747	29 8747
	FOR FLY / DELTA CLUTCH	€19,40	€19,40	€19,40	€19,40
	SPRINGS Ø INTERNAL CLUTCH BELL 105-107	29 7715	29 7456	29 7715	29 7714
	FOR ORIGINAL CLUTCH	€16,20	€16,20	€16,20	€13,80 Ø 105
	MUELLES Ø INTERNAL CLUTCH BELL 112	-	-	-	29 9605
	FOR ORIGINAL CLUTCH				€16,20 Ø 107

18 - To be assembled EXCLUSIVELY with MALOSSİ EXHAUST SYSTEMS

20 - ONLY for vehicles WITH Malossi MULTIVAR

21 - ONLY for vehicles WITH Malossi MULTIVAR AND PISTON WITH PIN Ø 12

27 - For vehicles with YAMAHA FLYWHEEL

MALAGUTI

F10 WAP euro 2	F12-PHANTOM	F12-PHANTOM	F12 DIGIT KAT- PHANTOM	F12 DIGIT KAT- PHANTOM euro 2	F12 R ARIA euro 2	F12 R LC euro 2	F12-PHANTOM
(QJ*CMA03C*)					(QJ*CMA02C*)		
50 2T	50 2T	50 2T LC	50 2T LC	50 2T LC	50 2T	50 2T LC	100 2T
3113865 *18* €120,74 Ø 40 (12)	31 8562 1 €120,74 Ø 40 (10)	31 8556 1 €161,98 Ø 40 (10)	31 8556 1 €161,98 Ø 40 (10)	31 8556 1 €161,98 Ø 40 (10)	3113865 *18* €120,74 Ø 40 (12)	31 8556 1 €161,98 Ø 40 (10)	-
3113066 *18* €117,81 Ø 47 (12)	31 7083 1 €114,25 Ø 47 (10)	31 8284 1 €152,41 Ø 47 (10)	31 8284 1 €152,41 Ø 47 (10)	31 8284 1 €152,41 Ø 47 (10)	3113066 *18* €117,81 Ø 47 (12)	31 8284 1 €152,41 Ø 47 (10)	-
3113067 €97,90 Ø 47 (12)	31 7002 €97,90 Ø 47 (10)	-	-	-	3113067 €97,90 Ø 47 (12)	-	-
38 7246 €37,47 Ø 47	38 7246 €37,47 Ø 47	-	-	-	38 7246 €37,47 Ø 47	-	-
-	31 8437 1 €207,00 Ø 47 (10)	31 8430 1 €228,06 Ø 47 (10)	31 8430 1 €228,06 Ø 47 (10)	31 8430 1 €228,06 Ø 47 (10)	-	31 8430 1 €228,06 Ø 47 (10)	-
-	53 7891 €175,50	53 7891 €175,50	53 7891 *20* €175,50	53 7891 *20* €175,50	-	53 7891 *20* €175,50	-
5313587 €175,50	53 8009 €175,50	53 8009 €175,50	53 8009 *21* €175,50	53 8009 *21* €175,50	5313587 €175,50	53 8009 *21* €175,50	-
PG.473	PG.473	PG.473	PG.473	PG.473	PG.473	PG.473	-
-	55 8133 *27* €50,14	55 8133 *27* €50,14	55 8133 *27* €50,14	5512429 €203,57	-	-	-
-	55 8676 *32* €97,59	55 8676 *32* €97,59	55 8676 *32* €97,59	5513400 €169,58 2007->	-	5513400 €169,58	-
5113363 €60,00	51 7075 €58,71	51 7075 €58,71	51 7075 *PG* €58,71	51 7075 €58,71	5113363 €60,00	51 7075 *PG* €58,71	5111327 €58,71
61 9832 €17,04	6112730 €14,36	6112730 €14,36	6112730 €14,36	6112730 €14,36	61 9832 €17,04	6112730 €14,36	-
61 7587 €28,25	6112729 €25,23	6112729 €25,23	6112729 €25,23	6112729 €25,23	61 7587 €28,25	6112729 €25,23	61 8779 €31,05
66 9823.L0 gr.06 €9,50 66 9823.O0 gr.09 €9,50	66 9823.M0 €9,50 gr.07	66 9823.M0 €9,50 gr.07	66 9823.M0 €9,50 gr.07	66 9823.M0 €9,50 gr.07	66 9823.L0 gr.06 €9,50 66 9823.O0 gr.09 €9,50	66 9823.M0 €9,50 gr.07	66 9823.O0 €9,50 gr.09
66 9417.G0 €7,24 gr.06	66 9417.H0 €7,24 gr.06,5	66 9417.H0 €7,24 gr.06,5	66 9417.H0 €7,24 gr.06,5	66 9417.H0 €7,24 gr.06,5	66 9417.G0 €7,24 gr.06	66 9417.H0 €7,24 gr.06,5	66 9999.F0 €8,50 gr.06,5
61 7151 €21,28	61 7152 €21,71	61 7152 €21,71	61 7152 €21,71	61 7152 €21,71	61 7151 €21,28	61 7152 €21,71	-
PG.438	PG.438	PG.438	PG.438	PG.438	PG.438	PG.438	-
-	2512827 €4,45	2512827 €4,45	2512827 €4,45	2512827 €4,45	-	2512827 €4,45	-
61 8312 €85,57	61 8312 Ø 33 €85,57 61 9223 Ø 34 €85,57	61 8312 Ø 33 €85,57 61 9223 Ø 34 €85,57	61 8312 Ø 33 €85,57 61 9223 Ø 34 €85,57	61 8312 Ø 33 €85,57 61 9223 Ø 34 €85,57	61 8312 €85,57	61 8312 Ø 33 €85,57 61 9223 Ø 34 €85,57	-
52 8798 €47,30	52 8796 Ø 105 €53,26 52 9450 Ø 107 €47,30	52 8796 Ø 105 €53,26 52 9450 Ø 107 €47,30	52 9450 €47,30	52 9450 €47,30	52 8798 €47,30	52 9450 €47,30	52 8798 €47,30
52 7879 €77,89	52 7643 Ø 105 €77,89 52 9451 Ø 107 €77,89	52 7643 Ø 105 €77,89 52 9451 Ø 107 €77,89	52 9451 €77,89	52 9451 €77,89	52 7879 €77,89	52 9451 €77,89	52 7879 €77,89
-	7711124 €22,60 Ø 107	7711124 €22,60 Ø 107	7711124 €22,60 Ø 107	7711124 €22,60 Ø 107	-	7711124 €22,60 Ø 107	-
-	7711166 €33,45 Ø 107	7711166 €33,45 Ø 107	7711166 €33,45 Ø 107	7711166 €33,45 Ø 107	-	7711166 €33,45 Ø 107	-
-	5214112 €63,00 Ø 107	5214112 €63,00 Ø 107	5214112 €63,00 Ø 107	5214112 €63,00 Ø 107	-	5214112 €63,00 Ø 107	-
-	5214113 €93,84 Ø 107	5214113 €93,84 Ø 107	5214113 €93,84 Ø 107	5214113 €93,84 Ø 107	-	5214113 €93,84 Ø 107	-
29 8746 €14,50	29 8746 €14,50	29 8746 €14,50	29 8746 €14,50	29 8746 €14,50	29 8746 €14,50	29 8746 €14,50	29 8746 €14,50
29 8747 €19,40	29 8747 €19,40	29 8747 €19,40	29 8747 €19,40	29 8747 €19,40	29 8747 €19,40	29 8747 €19,40	29 8747 €19,40
2913851 €15,50	29 7714 €13,80 Ø 105	29 7714 €13,80 Ø 105	29 7714 €13,80 Ø 105	29 7714 €13,80 Ø 105	2913851 €15,50	29 7714 €13,80 Ø 105	29 7456 €16,20
-	29 9605 €16,20 Ø 107	29 9605 €16,20 Ø 107	29 9605 €16,20 Ø 107	29 9605 €16,20 Ø 107	-	29 9605 €16,20 Ø 107	-

32 - For vehicles with YAMAHA FLYWHEEL - If it is a DUCATI : TC UNIT K15 +BOBINA / RPM CONTROL 55 8765 € 127,73

PG - SPECIFICATIONS on the PAGE indicated in the TITLE of the LINE



MALOSSI

Scooter 2T

with ENGINE **MALAGUTI**

CIAK

CIAK

CROSSER CR1

F10

50 2T



100 2T

















50 2T

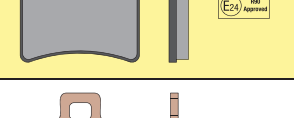
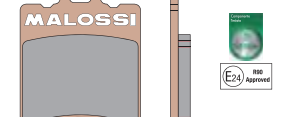

50 2T

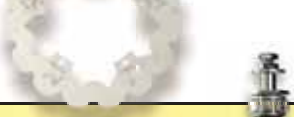

CHECK "TYPE" SPECIFICATION (HOMOLOGATION MARK)		50 2T	100 2T	50 2T	50 2T	
	CARBURETTOR	72 9215 € 78,76 Ø 17,5	-	-	72 9215 € 78,76 Ø 17,5	
	CARBURETTOR KIT Ø 19	1611042 € 118,04	-	1611044 € 115,40	1611042 € 118,04	
	CARBURETTOR KIT Ø 21	1610995 € 114,23	1611035 € 97,60	1611035 € 97,60	1610995 € 114,23	
	CARBURETTOR KIT Ø 22	1611031 € 120,28	-	-	1611031 € 120,28	
	REED VALVE CARBON FIBRE	27 7731.C0 € 48,95 VL12	-	-	27 7731.C0 € 48,95 VL12	
	PETALS SET FOR ORIGINAL REED VALVE	27 7054.C0 € 18,71	-	27 2728.C0 € 16,27	27 7054.C0 € 18,71	
	ART OF PERFORMANCE / FLIP HOMOLOGATED  	PG. 426 -	-	-	-	
	WILD LION HOMOLOGATED 	PG. 424 -	-	-	3216587 € 87,00	
	RED SPONGE FOR ORIGINAL AIR BOX	1411412 € 3,64	-	-	1411412 € 3,64	
	DOUBLE RED SPONGE FOR ORIGINAL AIR BOX	1414498 € 5,73	-	-	1414498 € 5,73	
	GEARS HTQ PRIMARY	67 7580 € 61,88 z 14/42	-	67 7149 € 53,80 z 14/34	67 7014 € 68,44 z 15/41	
	GEARS HTQ SECONDARY	PG. 478 -	-	-	-	
	ROLLER CRANKCASE	-	-	-	-	
	SCREEN	-	-	-	-	
		BRAKE PADS FRONT	6215042 € 5,72 1999->	6215042 € 5,72 1999->	6215046 € 6,35 1995->	6215042 € 5,72 1994->
		BRAKE PADS MHR FRONT	6215080 € 6,00 1999->	6215080 € 6,00 1999->	62 9087 € 6,24 1995->	6215080 € 6,00 1994->
BRAKE PADS MHR SYNT FRONT		6215007 € 11,96 1999->	6215007 € 11,96 1999->	-	6215007 € 11,96 1994->	
	BRAKE PADS REAR	-	-	-	-	
	BRAKE PADS MHR REAR	-	-	-	-	
	BRAKE PADS MHR SYNT REAR	-	-	-	-	
	BRAKE POWER REAR	-	-	-	6215802 € 18,64 1994->	
	BRAKE SHOES FRONT	-	-	-	62 8958 € 59,03 1994->	
	WHOOP DISC FRONT	-	-	-	-	
	WHOOP DISC REAR	-	-	-	-	
	WHOOP DISC REAR	-	-	-	-	
	RS1 - RS3 REAR SHOCK ABSORBER	-	-	-	4615434 € 88,74 RS1	
	RS24 - RS24/10 FRONT SHOCK ABSORBER	-	-	-	-	
	RS24 - RS24/10 - RS24/10-R REAR SHOCK ABSORBER	-	-	-	46 7591 € 230,79 RS24	
	RS24 FRONT + REAR	-	-	-	-	
	HORQUILLA F32S FORK STEMS Ø 32	-	-	-	-	
	HORQUILLA F37R MHR FORK STEMS Ø 37	-	-	-	-	

19 - for the ASSEMBLY MODIFY the CRANKCASE

25 - For vehicles with AIRY CRANKCASE

67 - TO COUPLE ONLY with MALOSSİ CYLINDERS: 3216986 € 122,00



MALOSSI

Scooter 2T

with ENGINE 

MALAGUTI

MBK

F15 FIREFOX

YESTERDAY

BOOSTER
euro 0-1BOOSTER
euro 2

(A137E)

▲ ATTENTION: ONLY FOR vehicles WITHOUT IMMOBILIZER KEY		50 2T	LC	50 2T	50 2T	50 2T			
	CYLINDER+HEAD CAST-IRON Ø 40	31 8556	1	31 8562	1	31 6901	1	31 6901	1
	(pin) ALUMINIUM Ø 40-41	€161,98	Ø 40 (10)	€120,74	Ø 40 (10)	€120,72	Ø 40 (10)	€120,72	Ø 40 (10)
	CYLINDER+HEAD	31 8284	1	31 7083	1	31 7237	1	31 7237	1
	(pin) CAST-IRON Ø 47	€152,41	Ø 47 (10)	€114,25	Ø 47 (10)	€112,27	Ø 47 (10)	€112,27	Ø 47 (10)
	CYLINDER CAST-IRON Ø 47-57,5	-		31 7002		31 6882		31 6882	
for ORIGINAL HEAD ALUM. Ø 47>57,5			€97,90	Ø 47 (10)	€97,90	Ø 47 (10)	€97,90	Ø 47 (10)	
HEAD HTSR			38 7246		3812770		3812770		
for Malossi CYLINDER			€37,47	Ø 47	€37,47	Ø 47	€37,47	Ø 47	
CYLINDER+HEAD MHR Replica ALUMINIUM		31 8430	1	31 8437	1	31 8501	1	31 8501	1
(pin) Ø 47		€228,06	Ø 47 (10)	€207,00	Ø 47 (10)	€201,93	Ø 47 (10)	€201,93	Ø 47 (10)
	CRANKSHAFTS RHQ	53 7891		53 7891		53 7621		53 7621	
	PIN Ø 10	€175,50		€175,50		€175,50		€175,50	
	CRANKSHAFTS RHQ	53 8009		53 8009		53 8008		53 8008	
	PIN Ø 12	€175,50		€175,50		€163,04		€163,04	
	RADIAL ROLLER BEARING FOR CRANKSHAFT	PG. 473		PG.473		PG.473		PG.473	
	ELECTRONIC CONTROLLER	55 8133	*27*	55 8133	*27*	55 8133		-	
		€50,14		€50,14		€50,14		-	
	ELECTRONIC CONTROLLER	55 8676	*32*	55 8676	*32*	55 8676		5512790	
	RPM CONTROL	€97,59		€97,59		€97,59		€157,87	
	MULTIVAR	51 7075		51 7075		51 7075		51 7075	
	VARIATOR	€58,71		€58,71		€58,71		€58,71	
	X SPECIAL BELT	6112730		6112741		6112730		6112730	
	BELT	€14,36		€15,25		€14,36		€14,36	
	X K BELT	6112729		6112742		6112729		6112729	
BELT	€25,23		€26,33		€25,23		€25,23		
	HTRoll	66 9823.M0		66 9823.M0		66 9823.M0		66 9823.M0	
	ROLLERS FOR MULTIVAR	€9,50	gr.07	€9,50	gr.07	€9,50	gr.07	€9,50	gr.07
	HTRoll	66 9417.H0		66 9417.H0		66 9417.H0		66 9417.F0	
	ROLLERS FOR ORIGINAL VARIATOR	€7,24	gr.06,5	€7,24	gr.06,5	€7,24	gr.06,5	€7,24	gr.05,4
	VENTILVAR	61 7152		61 7152		61 7152		61 7152	
	FIXED HALF-PULLEY	€21,71		€21,71		€21,71		€21,71	
	VARIABLE-SPEED DRIVE ADJUSTER SPRING	PG. 438		PG.438		PG.438		PG.438	
	FOR VARIATOR								
	TORSION CONTROLLER	2512827		2512827		2512827		2512827	
	ANTIFRICTION FIFTH WHEEL	€4,45		€4,45		€4,45		€4,45	
	TORQUE DRIVER	61 8312 Ø 33	€85,57	61 8312 Ø 33	€85,57	61 8312 Ø 33	€85,57	6112766	
	MOBILE DRIVEN SPLIT PULLEY	61 9223 Ø 34	€85,57	61 9223 Ø 34	€85,57	61 9223 Ø 34	€85,57	€83,89	
	FLY CLUTCH	52 9450		52 9450		52 8796 Ø 105	€53,26	52 8797	
	NOT ADJUSTABLE CLUTCH	€47,30		€47,30		52 9450 Ø 107	€47,30	€47,30	
	DELTA CLUTCH	52 9451		52 9451		52 7643 Ø 105	€77,89	52 7880	
	ADJUSTABLE CLUTCH	€77,89		€77,89		52 9451 Ø 107	€77,89	€77,89	
	CLUTCH BELL	7711124		7711124		7711124		7711124	
	CLUTCH BELL (SMOOTH RING)	€22,60	Ø 107	€22,60	Ø 107	€22,60	Ø 107	€22,60	Ø 107
	WING CLUTCH BELL	7711166		7711166		7711166		7711166	
	CLUTCH BELL (FINNED RING)	€33,45	Ø 107	€33,45	Ø 107	€33,45	Ø 107	€33,45	Ø 107
	FLY SYSTEM	5214112		5214112		5214112		-	
	CLUTCH BELL + NOT ADJUSTABLE CLUTCH	€63,00	Ø 107	€63,00	Ø 107	€63,00	Ø 107	-	
	DELTA SYSTEM	5214113		5214113		5214113		-	
	CLUTCH BELL + ADJUSTABLE CLUTCH	€93,84	Ø 107	€93,84	Ø 107	€93,84	Ø 107	-	
	SPORT SPRINGS	29 8746		29 8746		29 8746		29 8746	
	FOR FLY / DELTA CLUTCH	€14,50		€14,50		€14,50		€14,50	
	MHR SPRINGS	29 8747		29 8747		29 8747		29 8747	
	FOR FLY / DELTA CLUTCH	€19,40		€19,40		€19,40		€19,40	
	SPRINGS Ø INTERNAL CLUTCH BELL 105-107	29 7714		29 7714		29 7714		29 7454	
FOR ORIGINAL CLUTCH	€13,80	Ø 105	€13,80	Ø 105	€13,80	Ø 105	€16,20		
	MUELLES Ø INTERNAL CLUTCH BELL 112	29 9605		29 9605		29 9605		-	
	FOR ORIGINAL CLUTCH	€16,20	Ø 107	€16,20	Ø 107	€16,20	Ø 107	-	

27 - For vehicles with YAMAHA FLYWHEEL

32 - For vehicles with YAMAHA FLYWHEEL - If it is a DUCATI : TC UNIT K15 +BOBINA / RPM CONTROL 55 8765 € 127,73

PG - SPECIFICATIONS on the PAGE indicated in the TITLE of the LINE

MBK

BOOSTER NAKED euro 2	BOOSTER NG euro 0-1	BOOSTER NG euro 2	BOOSTER ROCKET euro 0-1	BOOSTER ROCKET euro 2	BOOSTER SPIRIT euro 0-1	BOOSTER	EVOLIS
(A137E)		(A137E)		(A137E)			
50 2T	50 2T	50 2T	50 2T	50 2T	50 2T	100 2T	50 2T
31 6901 1 €120,72 Ø 40 (10)	31 6901 1 €120,72 Ø 40 (10)	31 6901 1 €120,72 Ø 40 (10)	31 6901 1 €120,72 Ø 40 (10)	31 6901 1 €120,72 Ø 40 (10)	31 6901 1 €120,72 Ø 40 (10)	-	31 8562 1 €120,74 Ø 40 (10)
31 7237 1 €112,27 Ø 47 (10)	31 7237 1 €112,27 Ø 47 (10)	31 7237 1 €112,27 Ø 47 (10)	31 7237 1 €112,27 Ø 47 (10)	31 7237 1 €112,27 Ø 47 (10)	31 7237 1 €112,27 Ø 47 (10)	-	31 7083 1 €114,25 Ø 47 (10)
31 6882 €97,90 Ø 47 (10)	31 6882 €97,90 Ø 47 (10)	31 6882 €97,90 Ø 47 (10)	31 6882 €97,90 Ø 47 (10)	31 6882 €97,90 Ø 47 (10)	31 6882 €97,90 Ø 47 (10)	3111374 €167,85 Ø 57,5 (14)	31 7002 €97,90 Ø 47 (10)
3812770 €37,47 Ø 47	3812770 €37,47 Ø 47	3812770 €37,47 Ø 47	3812770 €37,47 Ø 47	3812770 €37,47 Ø 47	3812770 €37,47 Ø 47	-	38 7246 €37,47 Ø 47
31 8501 1 €201,93 Ø 47 (10)	31 8501 1 €201,93 Ø 47 (10)	31 8501 1 €201,93 Ø 47 (10)	31 8501 1 €201,93 Ø 47 (10)	31 8501 1 €201,93 Ø 47 (10)	31 8501 1 €201,93 Ø 47 (10)	-	31 8437 1 €207,00 Ø 47 (10)
53 7621 €175,50	53 7621 €175,50	53 7621 €175,50	53 7621 €175,50	53 7621 €175,50	53 7621 €175,50	-	53 7891 €175,50
53 8008 €163,04	53 8008 €163,04	53 8008 €163,04	53 8008 €163,04	53 8008 €163,04	53 8008 €163,04	-	53 8009 €175,50
PG.473	PG.473	PG.473	PG.473	PG.473	PG.473	-	PG.473
-	55 8133 €50,14	-	55 8133 €50,14	-	55 8133 €50,14	-	55 8133 €50,14
5512790 €157,87	55 8676 €97,59	5512790 €157,87	55 8676 €97,59	5512790 €157,87	55 8676 €97,59	-	55 8676 €97,59
51 7075 €58,71	51 7075 €58,71	51 7075 €58,71	51 7075 €58,71	51 7075 €58,71	51 7075 *PG* €58,71	5111380 €66,95	51 7075 €58,71
6112730 €14,36	6112730 €14,36	6112730 €14,36	6112730 €14,36	6112730 €14,36	6112730 €14,36	-	6112741 €15,25
6112729 €25,23	6112729 €25,23	6112729 €25,23	6112729 €25,23	6112729 €25,23	6112729 €25,23	6112959 €28,51	6112742 €26,33
66 9823.M0 €9,50 gr.07	66 9823.M0 €9,50 gr.07	66 9823.M0 €9,50 gr.07	66 9823.M0 €9,50 gr.07	66 9823.M0 €9,50 gr.07	66 9823.M0 €9,50 gr.07	66 9420.J0 €10,00 gr.11	66 9823.M0 €9,50 gr.07
66 9417.F0 €7,24 gr.05,4	66 9417.I0 €7,24 gr.06,8	66 9417.F0 €7,24 gr.05,4	66 9417.I0 €7,24 gr.06,8	66 9417.F0 €7,24 gr.05,4	66 9417.I0 €7,24 gr.06,8	66 9417.N0 €7,24 gr.08,3	66 9417.L0 €7,24 gr.07,2
61 7152 €21,71	61 7152 €21,71	61 7152 €21,71	61 7152 €21,71	61 7152 €21,71	61 7152 €21,71	-	61 7152 €21,71
PG.438	PG.438	PG.438	PG.438	PG.438	PG.438	2911388.Y0 *PG* €10,71	PG.438
2512827 €4,45	2512827 €4,45	2512827 €4,45	2512827 €4,45	2512827 €4,45	2512827 €4,45	2512827 €4,45	2512827 €4,45
6112766 €83,89	61 8312 Ø 33 €85,57 61 9223 Ø 34 €85,57	6112766 €83,89	61 8312 Ø 33 €85,57 61 9223 Ø 34 €85,57	6112766 €83,89	61 8312 Ø 33 €85,57 61 9223 Ø 34 €85,57	61 8312 €85,57	61 8312 Ø 33 €85,57 61 9223 Ø 34 €85,57
52 8797 €47,30	52 8796 Ø 105 €53,26 52 9450 Ø 107 €47,30	52 8797 €47,30	52 8796 Ø 105 €53,26 52 9450 Ø 107 €47,30	52 8797 €47,30	52 8796 Ø 105 €53,26 52 9450 Ø 107 €47,30	52 8798 €47,30	52 8798 €47,30
52 7880 €77,89	52 7643 Ø 105 €77,89 52 9451 Ø 107 €77,89	52 7880 €77,89	52 7643 Ø 105 €77,89 52 9451 Ø 107 €77,89	52 7880 €77,89	52 7643 Ø 105 €77,89 52 9451 Ø 107 €77,89	52 7879 €77,89	52 7879 €77,89
7711124 €22,60 Ø 107	7711124 €22,60 Ø 107	7711124 €22,60 Ø 107	7711124 €22,60 Ø 107	7711124 €22,60 Ø 107	7711124 €22,60 Ø 107	-	-
7711166 €33,45 Ø 107	7711166 €33,45 Ø 107	7711166 €33,45 Ø 107	7711166 €33,45 Ø 107	7711166 €33,45 Ø 107	7711166 €33,45 Ø 107	-	-
-	5214112 €63,00 Ø 107	-	5214112 €63,00 Ø 107	-	5214112 €63,00 Ø 107	-	-
-	5214113 €93,84 Ø 107	-	5214113 €93,84 Ø 107	-	5214113 €93,84 Ø 107	-	-
29 8746 €14,50	29 8746 €14,50	29 8746 €14,50	29 8746 €14,50	29 8746 €14,50	29 8746 €14,50	29 8746 €14,50	29 8746 €14,50
29 8747 €19,40	29 8747 €19,40	29 8747 €19,40	29 8747 €19,40	29 8747 €19,40	29 8747 €19,40	29 8747 €19,40	29 8747 €19,40
29 7454 €16,20	29 7714 €13,80 Ø 105	29 7454 €16,20	29 7714 €13,80 Ø 105	29 7454 €16,20	29 7714 €13,80 Ø 105	29 7715 €16,20	29 7714 Ø 105 €13,80 29 9605 Ø 107 €16,20
-	29 9605 €16,20 Ø 107	-	29 9605 €16,20 Ø 107	-	29 9605 €16,20 Ø 107	-	29 7715 €16,20 Ø 112



MALOSSİ

Scooter 2T

with ENGINE 

MALAGUTI

MBK

F15 FIREFOX

YESTERDAY

BOOSTER
euro 0-1BOOSTER
euro 2

(A137E)

50 2T

LC

50 2T

















50 2T

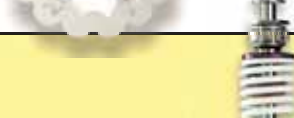

50 2T

 CHECK "TYPE" SPECIFICATION (HOMOLOGATION MARK)

	CARBURETTOR		72 9215 € 78,76 Ø 17,5	72 9215 € 78,76 Ø 17,5	72 8121 Ø 17,5 € 81,54 72 7085 Ø 16 € 80,08	72 8121 € 81,54 Ø 17,5
	CARBURETTOR KIT	Ø 19	1611042 € 118,04	1611042 € 118,04	1611024 € 97,95	1611024 € 97,95
	CARBURETTOR KIT	Ø 21	1610995 € 114,23	1610995 € 114,23	1610985 € 93,98	1610985 € 93,98
	CARBURETTOR KIT	Ø 22	1611031 € 120,28	1611031 € 120,28	-	-
	REED VALVE CARBON FIBRE		27 7731.C0 € 48,95 VL12	27 7731.C0 € 48,95 VL12	27 7441.C0 € 46,02 VL10	27 7441.C0 € 46,02 VL10
	PETALS SET FOR ORIGINAL REED VALVE		27 7054.C0 € 18,71	27 7054.C0 € 18,71	27 3549.C0 € 16,19	27 3549.C0 € 16,19
	ART OF PERFORMANCE / FLIP HOMOLOGATED 		-	-	*33*	*33*
	WILD LION HOMOLOGATED 		-	-	3216586 *34* € 87,00	3216586 *34* € 87,00
	RED SPONGE FOR ORIGINAL AIR BOX		1411413 € 3,95	1411412 € 3,64	1411414 € 4,05 1990-94	1411414 € 4,05
	DOUBLE RED SPONGE FOR ORIGINAL AIR BOX		-	1414498 € 5,73	1414495 € 7,62 1990 -94	1414495 € 7,62
	GEARS HTQ PRIMARY		6714039 € 57,67 z 13/44	67 7014 € 68,44 z 15/41	67 3677 € 57,67 z 16/40	67 3677 € 57,67 z 16/40
	GEARS HTQ SECONDARY		PG. 478 6714774 z 15/42 € 67,32 6714775 z 14/43 € 67,32	-	-	-
	ROLLER CRANKCASE		2515482 € 95,00	-	2515482 € 95,00	2515482 € 95,00
	SCREEN		-	-	-	-
	BRAKE PADS	FRONT	6215050 € 6,24 1996->	6215042 € 5,72 1998->	-	6215042 € 5,72
	BRAKE PADS MHR	FRONT	62 9841 € 6,10 1996->	6215080 € 6,00 1998->	-	6215080 € 6,00
	BRAKE PADS MHR SYNT	FRONT	-	6215007 € 11,96 1998->	-	6215007 € 11,96
	BRAKE PADS	REAR	6215042 € 5,72 1998->	-	-	-
	BRAKE PADS MHR	REAR	6215080 € 6,00 1998->	-	-	-
	BRAKE PADS MHR SYNT	REAR	6215007 € 11,96 1998->	-	-	-
	BRAKE POWER	REAR	6215802	6215802	6215834 € 21,50	6215834
	BRAKE SHOES	FRONT	€ 18,64 1996->97	€ 18,64 1998->	6215834 € 21,50	€ 21,50
	WHOOP DISC	FRONT	-	62 8958 € 59,03 1998->	-	62 8961 € 73,03
	WHOOP DISC	REAR	-	-	-	-
	RS1 - RS3	REAR SHOCK ABSORBER	-	4615434 € 88,74	4615434 € 88,74	46 7905 € 140,92
	RS24 - RS24/10	FRONT SHOCK ABSORBER	-	-	-	-
	RS24 - RS24/10 - RS24/10-R	REAR SHOCK ABSORBER	-	46 7591 € 230,79	46 7591 € 230,79	46 7588 € 255,97
	RS24	FRONT + REAR	-	-	-	-
	HORQUILLA F32S	FORK STEMS Ø 32	-	-	-	-
	HORQUILLA F37R MHR	FORK STEMS Ø 37	-	-	-	-

33 - ONLY for BOOSTER R: 3216693 FLIP - 3215170 ART OF PERFORMANCE € 175,70

34 - ALSO for BOOSTER R



MALOSSI

Scooter 2T

with ENGINE 

MBK

FIZZ

FLIPPER

FORTE

MACH G

(▲) ATTENTION: ONLY FOR vehicles WITHOUT IMMOBILIZER KEY

		50 2T 	50 2T 	50 2T 	50 2T 
	CYLINDER+HEAD CAST-IRON Ø 40	31 8562 1	31 8562 1	31 8562 1	31 8562 1
	(pin) ALUMINIUM Ø 40-41	€120,74 Ø 40 (10)	€120,74 Ø 40 (10)	€120,74 Ø 40 (10)	€120,74 Ø 40 (10)
	CYLINDER+HEAD	31 7083 1	31 7083 1	31 7083 1	31 7083 1
	(pin) CAST-IRON Ø 47	€114,25 Ø 47 (10)	€114,25 Ø 47 (10)	€114,25 Ø 47 (10)	€114,25 Ø 47 (10)
	CYLINDER CAST-IRON Ø 47-57,5	31 7002	31 7002	31 7002	31 7002
for ORIGINAL HEAD ALUM. Ø 47>57,5	€97,90 Ø 47 (10)	€97,90 Ø 47 (10)	€97,90 Ø 47 (10)	€97,90 Ø 47 (10)	
	HEAD HTSR	38 7246	38 7246	38 7246	38 7246
	for Malossi CYLINDER	€37,47 Ø 47	€37,47 Ø 47	€37,47 Ø 47	€37,47 Ø 47
	CYLINDER+HEAD MHR Replica ALUMINIUM	31 8437 1	31 8437 1	31 8437 1	31 8437 1
	(pin) Ø 47	€207,00 Ø 47 (10)	€207,00 Ø 47 (10)	€207,00 Ø 47 (10)	€207,00 Ø 47 (10)
	CRANKSHAFTS RHQ	53 7891	53 7891	53 7891	53 7891
	PIN Ø 10	€175,50	€175,50	€175,50	€175,50
	CRANKSHAFTS RHQ	53 8009	53 8009	53 8009	53 8009
	PIN Ø 12	€175,50	€175,50	€175,50	€175,50
	RADIAL ROLLER BEARING FOR CRANKSHAFT	PG.473	PG.473	PG.473	PG.473
	ELECTRONIC CONTROLLER	55 8133	55 8133	55 8133	55 8133
		€50,14	€50,14 euro 0-1	€50,14	€50,14 euro 0-1
	ELECTRONIC CONTROLLER	55 8676	55 8676 euro 0-1 €97,59	55 8676	55 8676 euro 0-1 €97,59
	RPM CONTROL	€97,59	5512790 euro 2 €157,87	€97,59	5512790 euro 2 €157,87
	MULTIVAR	51 7075	51 7075	51 7075	51 7075
	VARIATOR	€58,71	€58,71	€58,71	€58,71
	X SPECIAL BELT	6112741	6112730	6112741	6112730
	BELT	€15,25	€14,36	€15,25	€14,36
	X K BELT	6112742	6112729	6112742	6112729
BELT	€26,33	€25,23	€26,33	€25,23	
	HTRoll	66 9823.M0	66 9823.M0	66 9823.M0	66 9823.M0
	ROLLERS FOR MULTIVAR	€9,50 gr.07	€9,50 gr.07	€9,50 gr.07	€9,50 gr.07
	HTRoll	66 9417.I0	66 9417.I0	66 9417.L0	66 9417.H0
	ROLLERS FOR ORIGINAL VARIATOR	€7,24 gr.06,8	€7,24 gr.06,8	€7,24 gr.07,2	€7,24 gr.06,5
	VENTILVAR	61 7152	61 7152	61 7152	61 7152
	FIXED HALF-PULLEY	€21,71	€21,71	€21,71	€21,71
	VARIABLE-SPEED DRIVE ADJUSTER SPRING	PG.438	PG.438	PG.438	PG.438
	FOR VARIATOR				
	TORSION CONTROLLER	2512827	2512827	2512827	2512827
	ANTIFRICTION FIFTH WHEEL	€4,45	€4,45	€4,45	€4,45
	TORQUE DRIVER	61 8312 Ø 33 €85,57	61 8312 Ø 33 €85,57	61 8312 Ø 33 €85,57	61 8312 Ø 33 €85,57
	MOBILE DRIVEN SPLIT PULLEY	61 9223 Ø 34 €85,57	61 9223 Ø 34 €85,57	61 9223 Ø 34 €85,57	61 9223 Ø 34 €85,57
	FLY CLUTCH	52 8798	52 9450	52 8796 Ø 105 €53,26	52 9450
	NOT ADJUSTABLE CLUTCH	€47,30	€47,30	52 9450 Ø 107 €47,30	€47,30
	DELTA CLUTCH	52 7879	52 9451	52 7643 Ø 105 €77,89	52 9451
	ADJUSTABLE CLUTCH	€77,89	€77,89	52 9451 Ø 107 €77,89	€77,89
	CLUTCH BELL	-	7711124	7711124	7711124
	CLUTCH BELL (SMOOTH RING)		€22,60 Ø 107	€22,60 Ø 107	€22,60 Ø 107
	WING CLUTCH BELL	-	7711166	7711166	7711166
	CLUTCH BELL (FINNED RING)		€33,45 Ø 107	€33,45 Ø 107	€33,45 Ø 107
	FLY SYSTEM	-	5214112	5214112	5214112
	CLUTCH BELL + NOT ADJUSTABLE CLUTCH		€63,00 Ø 107	€63,00 Ø 107	€63,00 Ø 107
	DELTA SYSTEM	-	5214113	5214113	5214113
	CLUTCH BELL + ADJUSTABLE CLUTCH		€93,84 Ø 107	€93,84 Ø 107	€93,84 Ø 107
	SPORT SPRINGS	29 8746	29 8746	29 8746	29 8746
	FOR FLY / DELTA CLUTCH	€14,50	€14,50	€14,50	€14,50
	MHR SPRINGS	29 8747	29 8747	29 8747	29 8747
	FOR FLY / DELTA CLUTCH	€19,40	€19,40	€19,40	€19,40
	SPRINGS Ø INTERNAL CLUTCH BELL 105-107	29 7714 Ø 105 €13,80	29 7714	29 7714	29 7714
FOR ORIGINAL CLUTCH	29 9605 Ø 107 €16,20	€13,80 Ø 105	€13,80 Ø 105	€13,80 Ø 105	
MUELLES Ø INTERNAL CLUTCH BELL 112	29 7715	29 9605	29 9605	29 9605	
FOR ORIGINAL CLUTCH	€16,20 Ø 112	€16,20 Ø 107	€16,20 Ø 107	€16,20 Ø 107	

PG - SPECIFICATIONS on the PAGE indicated in the TITLE of the LINE

MBK

MACH G		NITRO		NITRO		OVETTO		OVETTO		STUNT euro 0-1		STUNT euro 2		TARGET	
50 2T	LC	50 2T	LC	100 2T	☼	50 2T	☼	100 2T	☼	50 2T	☼	50 2T	☼	50 2T	☼
31 8556	1 €161,98 Ø 40 (10)	31 8556	1 €161,98 Ø 40 (10)	-		31 8562	1 €120,74 Ø 40 (10)	-		31 6901	1 €120,72 Ø 40 (10)	31 6901	1 €120,72 Ø 40 (10)	31 6901	1 €120,72 Ø 40 (10)
31 8284	1 €152,41 Ø 47 (10)	31 8284	1 €152,41 Ø 47 (10)	-		31 7083	1 €114,25 Ø 47 (10)	-		31 7237	1 €112,27 Ø 47 (10)	31 7237	1 €112,27 Ø 47 (10)	31 7237	1 €112,27 Ø 47 (10)
-		-		3111374	€167,85 Ø 57,5 (14)	31 7002	1 €97,90 Ø 47 (10)	3111374	€167,85 Ø 57,5 (14)	31 6882	1 €97,90 Ø 47 (10)	31 6882	1 €97,90 Ø 47 (10)	31 6882	1 €97,90 Ø 47 (10)
-		-		-		38 7246	€37,47 Ø 47	-		3812770	€37,47 Ø 47	3812770	€37,47 Ø 47	3812770	€37,47 Ø 47
31 8430	1 €228,06 Ø 47 (10)	31 8430	1 €228,06 Ø 47 (10)	-		31 8437	1 €207,00 Ø 47 (10)	-		31 8501	1 €201,93 Ø 47 (10)	31 8501	1 €201,93 Ø 47 (10)	31 8501	1 €201,93 Ø 47 (10)
53 7891	€175,50	53 7891	€175,50	-		53 7891	€175,50	-		53 7621	€175,50	53 7621	€175,50	53 8368	€98,06
53 8009	€175,50	53 8009	€175,50	-		53 8009	€175,50	-		53 8008	€163,04	53 8008	€163,04	-	
PG.473		PG.473		-		PG.473		-		PG.473		PG.473		PG.473	
55 8133	€50,14 euro 0-1	55 8133	€50,14 euro 0-1	-		55 8133	€50,14 euro 0-1	-		55 8133	€50,14	-		55 8133	€50,14
55 8676	euro 0-1 €97,59	55 8676	euro 0-1 €97,59	-		55 8676	euro 0-1 €97,59	-		55 8676	€97,59	5512790	€157,87	55 8676	€97,59
5512790	euro 2 €157,87	5512790	euro 2 €157,87	-		5512790	euro 2 €157,87	-		5512790	€97,59	5512790	€157,87	5512790	€97,59
51 7075	€58,71	51 7075	*PG* €58,71	5111380	€66,95	51 7075	€58,71	5111380	€66,95	51 7075	€58,71	51 7075	€58,71	51 7075	€58,71
6112730	€14,36	6112730	€14,36	-		6112730	€14,36	-		6112730	€14,36	6112730	€14,36	6112741	€15,25
6112729	€25,23	6112729	€25,23	6112959	€28,51	6112729	€25,23	6112959	€28,51	6112729	€25,23	6112729	€25,23	6112742	€26,33
66 9823.M0	€9,50 gr.07	66 9823.M0	€9,50 gr.07	66 9420.J0	€10,00 gr.11	66 9823.M0	€9,50 gr.07	66 9420.J0	€10,00 gr.11	66 9823.M0	€9,50 gr.07	66 9823.M0	€9,50 gr.07	66 9823.M0	€9,50 gr.07
66 9417.F0	€7,24 gr.05,4	66 9417.F0	€7,24 gr.05,4	66 9417.N0	€7,24 gr.08,3	66 9417.H0	€7,24 gr.06,5	66 9417.N0	€7,24 gr.08,3	66 9417.H0	€7,24 gr.06,5	66 9417.F0	€7,24 gr.05,4	66 9417.H0	€7,24 gr.06,5
61 7152	€21,71	61 7152	€21,71	-		61 7152	€21,71	-		61 7152	€21,71	61 7152	€21,71	61 7152	€21,71
PG.438		PG.438		2911388.Y0	*PG* €10,71	PG.438		2911388.Y0	*PG* €10,71	PG.438		PG.438		PG.438	
2512827	€4,45	2512827	€4,45	2512827	€4,45	2512827	€4,45	2512827	€4,45	2512827	€4,45	2512827	€4,45	2512827	€4,45
61 8312	Ø 33 €85,57	61 8312	Ø 33 €85,57	61 8312	€85,57	61 8312	Ø 33 €85,57	61 8312	€85,57	61 8312	Ø 33 €85,57	6112766	€83,89	61 8312	€85,57
61 9223	Ø 34 €85,57	61 9223	Ø 34 €85,57	61 9223	Ø 34 €85,57	61 9223	Ø 34 €85,57	61 9223	Ø 34 €85,57	61 9223	Ø 34 €85,57	61 9223	Ø 34 €85,57	61 9223	Ø 34 €85,57
52 9450	€47,30	52 9450	€47,30	52 8798	€47,30	52 9450	€47,30	52 8798	€47,30	52 9450	€47,30	52 8797	€47,30	52 8796	€53,26
52 9451	€77,89	52 9451	€77,89	52 7879	€77,89	52 9451	€77,89	52 7879	€77,89	52 9451	€77,89	52 7880	€77,89	52 7643	€77,89
7711124	€22,60 Ø 107	7711124	€22,60 Ø 107	-		7711124	€22,60 Ø 107	-		7711124	€22,60 Ø 107	7711124	€22,60 Ø 107	-	
7711166	€33,45 Ø 107	7711166	€33,45 Ø 107	-		7711166	€33,45 Ø 107	-		7711166	€33,45 Ø 107	7711166	€33,45 Ø 107	-	
5214112	€63,00 Ø 107	5214112	€63,00 Ø 107	-		5214112	€63,00 Ø 107	-		5214112	€63,00 Ø 107	-		-	
5214113	€93,84 Ø 107	5214113	€93,84 Ø 107	-		5214113	€93,84 Ø 107	-		5214113	€93,84 Ø 107	-		-	
29 8746	€14,50	29 8746	€14,50	29 8746	€14,50	29 8746	€14,50	29 8746	€14,50	29 8746	€14,50	29 8746	€14,50	29 8746	€14,50
29 8747	€19,40	29 8747	€19,40	29 8747	€19,40	29 8747	€19,40	29 8747	€19,40	29 8747	€19,40	29 8747	€19,40	29 8747	€19,40
29 7714	€13,80 Ø 105	29 7714	€13,80 Ø 105	29 7715	€16,20	29 7714	€13,80 Ø 105	29 7715	€16,20	-		29 7454	€16,20	29 7714	€13,80 Ø 105
29 9605	€16,20 Ø 107	29 9605	€16,20 Ø 107	-		29 9605	€16,20 Ø 107	-		-		-		29 9605	€16,20 Ø 107



MALOSSI

Scooter 2T

with ENGINE 

MBK

FIZZ

FLIPPER

FORTE

MACH G

50 2T



50 2T















50 2T

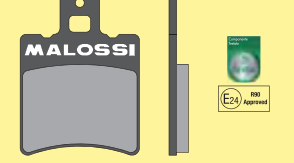
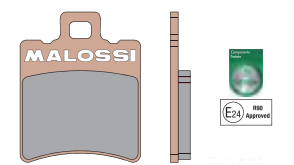

50 2T

**() CHECK "TYPE" SPECIFICATION (HOMOLOGATION MARK)**

	CARBURETTOR		72 9215 € 78,76 Ø 17,5	72 9215 € 78,76 Ø 17,5	72 9215 € 78,76 Ø 17,5	72 8121 € 81,54 Ø 17,5
	CARBURETTOR KIT	Ø 19	1611042 € 118,04	1611042 € 118,04	1611042 € 118,04	1611042 € 118,04
	CARBURETTOR KIT	Ø 21	1610995 € 114,23	1610995 € 114,23	1610995 € 114,23	1610995 € 114,23
	CARBURETTOR KIT	Ø 22	1611031 € 120,28	1611031 € 120,28	1611031 € 120,28	1611026 *15* € 107,68
	REED VALVE CARBON FIBRE		27 7731.C0 € 48,95 VL12	27 7731.C0 € 48,95 VL12	27 7731.C0 € 48,95 VL12	27 7731.C0 € 48,95 VL12
	PETALS SET FOR ORIGINAL REED VALVE		27 7054.C0 € 18,71	27 7054.C0 € 18,71	27 7054.C0 € 18,71	27 7054.C0 € 18,71
	ART OF PERFORMANCE / FLIP HOMOLOGATED 	PG. 426	-	-	-	-
	WILD LION HOMOLOGATED 	PG. 424	-	3216588 € 87,00	3216587 € 87,00	-
	RED SPONGE FOR ORIGINAL AIR BOX		1411412 € 3,64	1411416 € 3,81	1411412 € 3,64	1411412 € 3,64
	DOUBLE RED SPONGE FOR ORIGINAL AIR BOX		1414498 € 5,73	-	1414498 € 5,73	1414498 € 5,73
	GEARS HTQ PRIMARY		67 7014 € 68,44 z 15/41	6714039 € 57,67 z 13/44	67 7014 € 68,44 z 15/41	6714039 € 57,67 z 13/44
	GEARS HTQ SECONDARY	PG. 478	-	-	-	-
	ROLLER CRANKCASE		-	-	-	2515482 € 95,00
	BRAKE PADS	FRONT	6215043 € 5,80 1994->	-	6215043 € 5,80 1995->	-
	BRAKE PADS MHR	FRONT	62 9083 € 6,20 1994->	-	62 9083 € 6,20 1995->	-
	BRAKE PADS MHR SYNT	FRONT	6215008 € 11,96 1994->	-	6215008 € 11,96 1995->	-
	BRAKE PADS	REAR	-	-	-	-
	BRAKE PADS MHR	REAR	-	-	-	-
	BRAKE PADS MHR SYNT	REAR	-	-	-	-
	BRAKE POWER	REAR	6215834 € 21,50 1994->	6215834 € 21,50	6215834 € 21,50 1995->	-
	BRAKE SHOES	FRONT	-	-	-	-
	WHOOP DISC	FRONT	6214097 € 62,00 1994->	-	6214097 € 62,00 1995->	-
	WHOOP DISC	REAR	-	-	-	-
	RS1 - RS3	REAR SHOCK ABSORBER	4615434 € 88,74	-	4615434 € 88,74	-
	RS24 - RS24/10	FRONT SHOCK ABSORBER	-	-	-	-
	RS24 - RS24/10 - RS24/10-R	REAR SHOCK ABSORBER	46 7591 € 230,79	-	46 7591 € 230,79	-
	RS24	FRONT + REAR	-	-	-	-
	HORQUILLA F32S	FORK STEMS Ø 32	-	-	-	-
	HORQUILLA F37R MHR	FORK STEMS Ø 37	-	-	-	-

15 - WITH manual choke

82 - OVERSIZED WHOOP DISC KIT ext. Ø 250 - thickness 3 mm/ BRAKE CALIPER SUPP. CLAMP for ORIGINAL FORK, IS ALSO AVAILABLE: 6213297 € 189,95

MBK

MACH G	NITRO	NITRO	OVETTO	OVETTO	STUNT euro 0-1	STUNT euro 2	TARGET
50 2T LC	50 2T LC	100 2T	50 2T	100 2T	50 2T	50 2T	50 2T
72 8121 € 81,54 Ø 17,5	72 8121 € 81,54 Ø 17,5	-	72 8121 € 81,54 Ø 17,5	-	72 8121 € 81,54 Ø 17,5	72 8121 € 81,54 Ø 17,5	-
1611042 € 118,04	1611042 € 118,04	-	1611042 € 118,04	-	1611024 € 97,95	1611024 € 97,95	-
1610995 € 114,23	1610995 € 114,23	-	1610995 € 114,23	-	1610985 € 93,98	1610985 € 93,98	-
1611026 *15* € 107,68	1611026 *15* € 107,68	1611430 € 174,96	1611026 *15* € 107,68	1611430 € 174,96	-	-	-
27 7731.C0 € 48,95 VL12	27 7731.C0 € 48,95 VL12	27 7731.C0 € 48,95 VL12	27 7731.C0 € 48,95 VL12	27 7731.C0 € 48,95 VL12	27 7441.C0 € 46,02 VL10	27 7441.C0 € 46,02 VL10	27 7441.C0 € 46,02 VL10
27 7054.C0 € 18,71	27 7054.C0 € 18,71	27 7054.C0 € 18,71	27 7054.C0 € 18,71	27 7054.C0 € 18,71	27 3549.C0 € 16,19	27 3549.C0 € 16,19	27 3549.C0 € 16,19
-	3216691 € 122,00	3216691 € 122,00	3215172 € 120,00	-	-	-	-
-	3216583 € 87,00	-	3216588 € 87,00	-	3216586 € 87,00	-	-
1411412 € 3,64	1411412 € 3,64	-	1411412 € 3,64	-	-	1411414 € 4,05	-
1414498 € 5,73	1414498 € 5,73	-	1414498 € 5,73	-	-	1414495 € 7,62	-
6714039 € 57,67 z 13/44	6714039 € 57,67 z 13/44	6711486 € 76,18 z 15/42	6714039 € 57,67 z 13/44	6711486 € 76,18 z 15/42	67 3677 € 57,67 z 16/40	67 3677 € 57,67 z 16/40	-
-	6714774 z 15/42 € 67,32 6714775 z 14/43 € 67,32	-	6714774 z 15/42 € 67,32 6714775 z 14/43 € 67,32	-	-	-	-
2515482 € 95,00	2515482 € 95,00	-	2515482 € 95,00	-	2515482 € 95,00	2515482 € 95,00	-
-	-	-	-	-	-	-	-
-	6215043 € 5,80 1997->	6215042 € 5,72 2000->	6215043 € 5,80 1997->	6215042 € 5,72 2000->	6215042 € 5,72 2000->	6215042 € 5,72	6215044 € 6,97 1992->
-	62 9083 € 6,20 1997->	6215080 € 6,00 2000->	62 9083 € 6,20 1997->	6215080 € 6,00 2000->	6215080 € 6,00 2000->	6215080 € 6,00	62 9084 € 6,90 1992->
-	6215008 € 11,96 1997->	6215007 € 11,96 2000->	6215008 € 11,96 1997->	6215007 € 11,96 2000->	6215007 € 11,96 2000->	6215007 € 11,96	-
-	6215058 € 6,55 1997->	-	-	-	-	-	-
-	-	-	-	-	-	-	-
-	-	-	-	-	-	-	-
-	-	-	6215834 € 21,50 1997->	-	6215834 € 21,50 2000->	6215834 € 21,50	6215834 € 21,50 1992->
-	6213292 *82* € 72,56 1997->	-	6212603 € 72,56 1997->	6212603 € 72,56 2000->	6212603 € 72,56 2000->	6212603 € 72,56	6214097 € 62,00 1992->
-	-	-	-	-	-	-	-
-	4615433 € 90,78 46 8610 € 141,25	-	4615433 € 90,78 46 8610 € 141,25	-	-	46 7905 € 140,92	4615434 € 88,74
-	-	-	-	-	-	-	-
-	46 8611 € 219,76	-	46 8611 € 219,76	-	-	46 7588 € 255,97	46 7591 € 230,79
-	-	-	-	-	-	-	-
-	-	-	-	-	-	-	-



MALOSSI

Scooter 2T

with ENGINE **OVER****PEUGEOT**THOR
2013->

BUXY

BUXY RS

ELYSEO

(LJ1PE40MB)

50 2T

LC

50 2T



50 2T



50 2T

**(▲) ATTENTION: ONLY FOR vehicles WITHOUT IMMOBILIZER KEY**

	CYLINDER+HEAD CAST-IRON Ø 40	31 8556	1	31 8573	31 8573	31 8573	31 8573	
	(pin) ALUMINIUM Ø 40-41	€167,98	Ø 40 (10)	€124,91	Ø 40 (12)	€124,91	Ø 40 (12)	
	CYLINDER+HEAD	31 8284	1	31 7133	31 7133	31 7133	31 7133	
	(pin) CAST-IRON Ø 47	€152,41	Ø 47 (10)	€123,02	Ø 47 (12)	€123,02	Ø 47 (12)	
	CYLINDER CAST-IRON Ø 47-57,5	-	-	31 7132	31 7132	31 7132	31 7132	
for ORIGINAL HEAD ALUM. Ø 47>57,5	-	-	€103,12	Ø 47 (12)	€103,12	Ø 47 (12)	€103,12	Ø 47 (12)
HEAD HTSR	-	-	38 7362	38 7362	38 7362	38 7362	38 7362	
for Malossi CYLINDER	-	-	€37,45	Ø 47	€37,45	Ø 47	€37,45	Ø 47
CYLINDER+HEAD MHR Replica ALUMINIUM	31 8430	1	31 8640	31 8640	31 8640	31 8640	31 8640	
(pin) Ø 47	€228,06	Ø 47 (10)	€201,34	Ø 47 (12)	€201,34	Ø 47 (12)	€201,34	Ø 47 (12)
	CRANKSHAFTS RHQ	-	-	-	-	-	-	
	PIN Ø 10	-	-	53 8619	53 8619	53 8619	53 8619	
	CRANKSHAFTS RHQ	-	-	53 8619	53 8619	53 8619	53 8619	
	PIN Ø 12	-	-	€181,19	€181,19	€181,19	€181,19	
	RADIAL ROLLER BEARING	-	-	-	-	-	-	
FOR CRANKSHAFT	PG. 473	-	-	-	-	-	-	
	ELECTRONIC CONTROLLER	-	-	55 8132	55 8132	55 8132	55 8132	
		-	-	€50,14	€50,14	€50,14	€50,14	
	ELECTRONIC CONTROLLER	-	-	55 8675	55 8675	55 8675	55 8675	
	RPM CONTROL	-	-	€104,38	€104,38	€104,38	€104,38	
	MULTIVAR	5113363	-	51 8752	51 8752	51 8752	51 8752	
	VARIATOR	€60,00	-	€58,71	€58,71	€58,71	€58,71	
	X SPECIAL BELT	61 9832	-	6112735	6112735	6112735	6112735	
	BELT	€17,04	-	€15,46	€15,46	€15,46	€15,46	
	X K BELT	61 7587	-	6112736	6112736	6112736	6112736	
BELT	€28,25	-	€27,23	€27,23	€27,23	€27,23		
	HTRoll	66 9823.L0	gr.06 €9,50	66 9823.O0	66 9823.O0	66 9823.O0	66 9823.O0	
	ROLLERS FOR MULTIVAR	66 9823.O0	gr.09 €9,50	€9,50	gr.09	€9,50	gr.09	
	HTRoll	66 9417.G0	gr.06	66 9823.R0	66 9823.R0	66 9823.R0	66 9823.R0	
ROLLERS FOR ORIGINAL VARIATOR	€7,24	gr.06	€9,50	gr.08,5	€9,50	gr.08,5	€9,50	gr.09
	VENTILVAR	61 7151	-	-	-	-	-	
FIXED HALF-PULLEY	€21,28	-	-	-	-	-	-	
	VARIABLE-SPEED DRIVE ADJUSTER SPRING	PG. 438	PG.438	PG.438	PG.438	PG.438	PG.438	
	FOR VARIATOR	-	-	-	-	-	-	
	TORSION CONTROLLER	-	-	2512828	2512828	2512828	2512828	
	ANTIFRICTION FIFTH WHEEL	-	-	€4,45	€4,45	€4,45	€4,45	
	TORQUE DRIVER	61 8312	-	61 8317	61 8317	61 8317	61 8317	
	MOBILE DRIVEN SPLIT PULLEY	€85,57	-	€95,61	€95,61	€95,61	€95,61	
	FLY CLUTCH	52 8798	-	52 8797	52 8797	52 8797	52 8797	
	NOT ADJUSTABLE CLUTCH	€47,30	-	€47,30	€47,30	€47,30	€47,30	
	DELTA CLUTCH	52 7879	-	52 7880	52 7880	52 7880	52 7880	
	ADJUSTABLE CLUTCH	€77,89	-	€77,89	€77,89	€77,89	€77,89	
	CLUTCH BELL	-	-	7711115	7711115	7711115	7711115	
	CLUTCH BELL (SMOOTH RING)	-	-	€22,60	Ø 107	€22,60	Ø 107	
	WING CLUTCH BELL	-	-	7711207	7711207	7711207	7711207	
	CLUTCH BELL (FINNED RING)	-	-	€33,45	Ø 107	€33,45	Ø 107	
	FLY SYSTEM	-	-	5214111	5214111	5214111	5214111	
	CLUTCH BELL + NOT ADJUSTABLE CLUTCH	-	-	€63,00	Ø 107	€63,00	Ø 107	
	DELTA SYSTEM	-	-	5214110	5214110	5214110	5214110	
	CLUTCH BELL + ADJUSTABLE CLUTCH	-	-	€93,84	Ø 107	€93,84	Ø 107	
	SPORT SPRINGS	29 8746	-	29 8746	29 8746	29 8746	29 8746	
	FOR FLY / DELTA CLUTCH	€14,50	-	€14,50	€14,50	€14,50	€14,50	
	MHR SPRINGS	29 8747	-	29 8747	29 8747	29 8747	29 8747	
	FOR FLY / DELTA CLUTCH	€19,40	-	€19,40	€19,40	€19,40	€19,40	
	SPRINGS Ø INTERNAL CLUTCH BELL 105-107	29 7715	-	29 7454	29 7454	29 7454	29 7454	
FOR ORIGINAL CLUTCH	€16,20	-	€16,20	<-1996	€16,20	<-1996	€16,20	<-1996
MUELLES Ø INTERNAL CLUTCH BELL 112	-	-	29 9605	29 9605	29 9605	29 9605	29 9605	
FOR ORIGINAL CLUTCH	-	-	€16,20	1997->	€16,20	1997->	€16,20	1997->

***26* - NOT to be used on VEHICLE WITH Dellorto ORIGINAL EL. CONTROLLER**

PEUGEOT

ELYSEO	JET FORCE C-TECH	JET FORCE TSDI	LOOXOR	LOOXOR TSDI	LOOXOR	LUDIX	LUDIX BLASTER
		(HL 1)					(HL 2)
100 2T	50 2T LC	50 2T LC	50 2T	50 2T	100 2T	50 2T	50 2T LC
-	3112898 € 249,10 Ø 40 (12)	-	31 8573 € 124,91 Ø 40 (12)	-	-	3112904 € 249,10 Ø 40 (12)	3112898 € 249,10 Ø 40 (12)
-	3112893 € 190,21 Ø 47 (12)	3112502 € 355,75 Ø 47 (12)	31 7133 € 123,02 Ø 47 (12)	-	-	-	3112893 € 190,21 Ø 47 (12)
3111081 € 254,42 Ø 55 (14)	-	-	31 7132 € 103,12 Ø 47 (12)	-	3111081 € 254,42 Ø 55 (14)	-	-
-	-	-	38 7362 € 37,45 Ø 47	-	-	-	-
-	-	-	31 8640 € 201,34 Ø 47 (12)	-	-	3112901 € 239,30 Ø 47 (12)	-
-	-	-	-	-	-	-	-
-	5312781 € 312,69	5312781 € 312,69	-	-	-	5312781 € 312,69	5312781 € 312,69
-	-	-	-	-	-	-	-
-	55 8132 *26* € 50,14	PG.422	55 8132 € 50,14	-	-	-	55 8132 € 50,14
-	- *26*	-	55 8675 € 104,38	-	-	-	55 8675 € 104,38
5111558 KAT € 61,80 5111127 NO KAT € 62,83	51 8752 € 58,71	51 8752 € 58,71	51 8752 € 58,71	51 8752 € 58,71	-	51 8752 € 58,71	51 8752 € 58,71
-	6112735 € 15,46	6112735 € 15,46	6112735 € 15,46	-	-	6112735 € 15,46	6112735 € 15,46
6114118 € 38,25 NO KAT	6112736 € 27,23	6112736 € 27,23	6112736 € 27,23	6111108 € 27,80	-	6112736 € 27,23	6112736 € 27,23
66 9420.J0 gr.11 KAT € 10,00 66 9420.P0 gr.09,3 NO KAT € 10,00	66 9823.O0 € 9,50 gr.09	66 9823.O0 € 9,50 gr.09	66 9823.O0 € 9,50 gr.09	66 9823.O0 € 9,50 gr.09	-	66 9823.O0 € 9,50 gr.09	66 9823.O0 € 9,50 gr.09
-	-	-	-	66 9823.Q0 € 9,50 gr.07,5	-	-	-
-	-	-	-	-	-	-	-
-	PG.438	PG.438	PG.438	PG.438	-	PG.438	PG.438
-	2512828 € 4,45	2512828 € 4,45	2512828 € 4,45	2512828 € 4,45	-	2512828 € 4,45	2512828 € 4,45
-	-	61 8317 € 95,61	61 8317 € 95,61	61 8317 € 95,61	-	61 8317 € 95,61	61 8317 € 95,61
-	52 8797 € 47,30	52 8797 € 47,30	52 8797 € 47,30	52 8797 € 47,30	-	52 8797 € 47,30	52 8797 € 47,30
-	52 7880 € 77,89	52 7880 € 77,89	52 7880 € 77,89	52 7880 € 77,89	-	52 7880 € 77,89	52 7880 € 77,89
-	7711115 € 22,60 Ø 107	7711115 € 22,60 Ø 107	7711115 € 22,60 Ø 107	7711115 € 22,60 Ø 107	-	7711115 € 22,60 Ø 107	7711115 € 22,60 Ø 107
-	7711207 € 33,45 Ø 107	7711207 € 33,45 Ø 107	7711207 € 33,45 Ø 107	7711207 € 33,45 Ø 107	-	7711207 € 33,45 Ø 107	7711207 € 33,45 Ø 107
-	5214111 € 63,00 Ø 107	5214111 € 63,00 Ø 107	5214111 € 63,00 Ø 107	5214111 € 63,00 Ø 107	-	5214111 € 63,00 Ø 107	5214111 € 63,00 Ø 107
-	5214110 € 93,84 Ø 107	5214110 € 93,84 Ø 107	5214110 € 93,84 Ø 107	5214110 € 93,84 Ø 107	-	5214110 € 93,84 Ø 107	5214110 € 93,84 Ø 107
-	29 8746 € 14,50	29 8746 € 14,50	29 8746 € 14,50	29 8746 € 14,50	-	29 8746 € 14,50	29 8746 € 14,50
-	29 8747 € 19,40	29 8747 € 19,40	29 8747 € 19,40	29 8747 € 19,40	-	29 8747 € 19,40	29 8747 € 19,40
2911325 € 17,24	-	-	29 9605 € 16,20	-	2911325 € 17,24	-	-
-	-	-	-	-	-	-	-



MALOSSİ

Scooter 2T

with ENGINE **OVER****PEUGEOT**THOR
2013->

BUXY

BUXY RS

ELYSEO

(LJ1PE40MB)

50 2T

LC

50 2T

















50 2T







50 2T

**■ CHECK "TYPE" SPECIFICATION (HOMOLOGATION MARK)**

	CARBURETTOR		72 9215 € 78,76 Ø 17,5	-	-	-
	CARBURETTOR KIT Ø 19		1611042 € 118,04	1611027 € 125,27	1611027 € 125,27	1611027 € 125,27
	CARBURETTOR KIT Ø 21		1610995 € 114,23	-	-	-
	CARBURETTOR KIT Ø 22		-	-	-	-
	REED VALVE CARBON FIBRE		27 7731.CO *19* € 48,95 VL12	27 7440.CO € 49,00 VL9	27 7440.CO € 49,00 VL9	27 7440.CO € 49,00 VL9
	PETALS SET FOR ORIGINAL REED VALVE		27 7054.CO € 18,71	27 2728.CO € 16,27	27 2728.CO € 16,27	27 2728.CO € 16,27
	ART OF PERFORMANCE / FLIP HOMOLOGATED  	PG. 426	-	-	-	-
	WILD LION HOMOLOGATED 	PG. 424	-	-	-	3216584 € 87,00
	RED SPONGE FOR ORIGINAL AIR BOX		1414044 € 3,56	1411418 € 3,12	-	1411418 € 3,12
	DOUBLE RED SPONGE FOR ORIGINAL AIR BOX		1414483 € 5,30	1414494 € 5,87	-	1414494 € 5,87
	GEARS HTQ PRIMARY		-	67 8378 € 65,00 z 13/35	67 8378 € 65,00 z 13/35	67 8378 € 65,00 z 13/35
	GEARS HTQ SECONDARY	PG. 478	-	-	-	-
	ROLLER CRANKCASE		-	-	-	-
	SCREEN		-	-	-	-
	BRAKE PADS FRONT		-	6215042 € 5,72 1994->	6215059 € 8,84 1994->	6215051 € 5,72 1998->
	BRAKE PADS MHR FRONT		-	6215080 € 6,00 1994->	6212164 € 8,50 1994->	6215076 € 6,24 1998->
	BRAKE PADS MHR SYNT FRONT		-	6215007 € 11,96 1994->	-	6215005 € 11,96 1998->
	BRAKE PADS REAR		-	-	-	-
	BRAKE PADS MHR REAR		-	-	-	-
	BRAKE PADS MHR SYNT REAR		6215019 € 16,64	-	-	-
	BRAKE POWER REAR		-	6215834 € 21,50 1994->	6215834 € 21,50 1994->	6215802 € 18,64 1998->
	BRAKE POWER FRONT		-	6215834 € 21,50 1994->	6215834 € 21,50 1994->	6215802 € 18,64 1998->
	WHOOP DISC FRONT		6212603 € 72,56	6212603 € 72,56 1994->	6212603 € 72,56 1994->	-
	WHOOP DISC REAR		-	-	-	-
	RS1 - RS3 REAR SHOCK ABSORBER		-	4615433 € 90,78 46 8610 € 141,25	4615433 € 90,78 46 8610 € 141,25	-
	RS24 - RS24/10 FRONT SHOCK ABSORBER		-	-	-	-
	RS24 - RS24/10 - RS24/10-R REAR SHOCK ABSORBER		-	46 8611 € 219,76	46 8611 € 219,76	-
	RS24 FRONT + REAR		-	-	-	-
	HORQUILLA F32S FORK STEMS Ø 32		-	-	-	-
	HORQUILLA F37R MHR FORK STEMS Ø 37		-	-	-	-

19 - for the ASSEMBLY MODIFY the CRANKCASE

PEUGEOT

ELYSEO	JET FORCE C-TECH	JET FORCE TSDI	LOOXOR	LOOXOR TSDI	LOOXOR	LUDIX	LUDIX BLASTER
		<i>(HL 1)</i>					<i>(HL 2)</i>
100 2T 	50 2T LC	50 2T LC	50 2T 	50 2T 	100 2T 	50 2T 	50 2T LC
-	-	-	-	-	-	-	-
-	-	-	1611027 € 125,27	-	-	-	-
1611126 € 114,23	1610995 € 114,23	-	-	-	1611126 € 114,23	-	1610995 € 114,23
-	-	-	-	-	-	-	-
-	-	-	27 7440.C0 € 49,00 VL9	-	-	-	-
-	27 7054.C0 € 18,71	27 7054.C0 € 18,71	27 2728.C0 € 16,27	-	-	27 7054.C0 € 18,71	27 7054.C0 € 18,71
-	-	-	-	-	-	-	-
-	-	-	-	-	-	3216591 € 87,00	-
-	-	-	1411418 € 3,12	1411418 € 3,12	-	-	-
-	-	-	1414494 € 5,87	1414494 € 5,87	-	-	-
-	67 8378 € 65,00 z 13/35	67 8378 € 65,00 z 13/35	-	6712157 € 53,04 z 13/43	-	-	67 8378 € 65,00 z 13/35
-	-	-	-	-	-	-	-
-	-	-	-	-	-	-	-
6215051 € 5,72 1999->	6215051 € 5,72	6215051 € 5,72	6215051 € 5,72 2001->	6215051 € 5,72 2002->	6215051 € 5,72 2000->	-	6215051 € 5,72
6215076 € 6,24 1999->	6215076 € 6,24	6215076 € 6,24	6215076 € 6,24 2001->	6215076 € 6,24 2002->	6215076 € 6,24 2000->	-	6215076 € 6,24
6215005 € 11,96 1999->	6215005 € 11,96	6215005 € 11,96	6215005 € 11,96 2001->	6215005 € 11,96 2002->	6215005 € 11,96 2000->	-	6215005 € 11,96
-	6215051 € 5,72	6215051 € 5,72	-	-	-	-	6215051 € 5,72
-	6215076 € 6,24	6215076 € 6,24	-	-	6215076 € 6,24 2000->	-	6215076 € 6,24
-	6215005 € 11,96	6215005 € 11,96	-	-	6215005 € 11,96 2000->	-	6215005 € 11,96
-	-	-	-	-	-	-	-
-	-	-	-	-	-	-	-
-	-	-	-	46 7906 € 140,92	-	-	-
-	-	-	-	-	-	-	-
-	-	-	-	46 7589 € 221,96	-	-	-
-	-	-	-	-	-	-	-
-	-	-	-	-	-	-	-



MALOSSI

Scooter 2T

with ENGINE 

PEUGEOT

METAL-X

RAPIDO

SC L METROPOLIS

SPEEDAKE

50 2T



50 2T



50 2T



50 2T

**(▲) ATTENTION: ONLY FOR vehicles WITHOUT IMMOBILIZER KEY**

	CYLINDER+HEAD CAST-IRON Ø 40	31 8573	-	-	31 8573
	(pin) ALUMINIUM Ø 40-41	€124,91 Ø 40 (12)			€124,91 Ø 40 (12)
	CYLINDER+HEAD	31 7133	-	-	31 7133
	(pin) CAST-IRON Ø 47	€123,02 Ø 47 (12)			€123,02 Ø 47 (12)
	CYLINDER CAST-IRON Ø 47-57,5	31 7132	31 6405	31 6170 ¹	31 7132
for ORIGINAL HEAD ALUM. Ø 47>57,5	€103,12 Ø 47 (12)	€95,21 Ø 47 (10)	€95,13 Ø 47 (10)	€103,12 Ø 47 (12)	
	HEAD HTSR	38 7362	38 7157	38 7716	38 7362
	for Malossi CYLINDER	€37,45 Ø 47	€39,02 Ø 47	€42,32 Ø 47	€37,45 Ø 47
	CYLINDER+HEAD MHR Replica ALUMINIUM	31 8640	-	-	31 8640
	(pin) Ø 47	€201,34 Ø 47 (12)			€201,34 Ø 47 (12)
	CRANKSHAFTS RHQ	-	-	53 8053	-
	PIN Ø 10			€96,13	
	CRANKSHAFTS RHQ	53 8619	-	53 8123	53 8619
	PIN Ø 12	€181,19		€96,13	€181,19
	RADIAL ROLLER BEARING FOR CRANKSHAFT	-	-	-	-
	ELECTRONIC CONTROLLER	55 8132	55 8132	-	55 8132
		€50,14	€50,14		€50,14
	ELECTRONIC CONTROLLER RPM CONTROL	55 8675	55 8675	-	55 8675
		€104,38	€104,38		€104,38
	MULTIVAR VARIATOR	51 8752	51 7073	51 7074	51 8752
		€58,71	€58,71	€58,71	€58,71
	X SPECIAL BELT	6112735	61 7213	-	6112735
	BELT	€15,46	€13,94		€15,46
	X K BELT BELT	6112736	-	-	6112736
	€27,23			€27,23	
	HTRoll ROLLERS FOR MULTIVAR	66 9823.00	66 9823.M0	66 9823.L0	66 9823.00
		€9,50 gr.09	€9,50 gr.07	€9,50 gr.06	€9,50 gr.09
	HTRoll ROLLERS FOR ORIGINAL VARIATOR	66 9823.00	66 9823.R0	-	66 9823.R0
		€9,50 gr.09	€9,50 gr.08,5		€9,50 gr.08,5
	VENTILVAR FIXED HALF-PULLEY	-	-	61 7377	-
				€22,48	
	VARIABLE-SPEED DRIVE ADJUSTER SPRING FOR VARIATOR	PG. 438	PG.438	PG.438	PG.438
	TORSION CONTROLLER ANTIFRICTION FIFTH WHEEL	2512828	2512828	-	2512828
		€4,45	€4,45		€4,45
	TORQUE DRIVER MOBILE DRIVEN SPLIT PULLEY	61 8317	-	-	61 8317
		€95,61			€95,61
	FLY CLUTCH NOT ADJUSTABLE CLUTCH	52 8797	-	-	52 8797
		€47,30			€47,30
	DELTA CLUTCH ADJUSTABLE CLUTCH	52 7880	-	-	52 7880
		€77,89			€77,89
	CLUTCH BELL CLUTCH BELL (SMOOTH RING)	7711115	7711115	-	7711115
		€22,60 Ø 107	€22,60 Ø 107		€22,60 Ø 107
	WING CLUTCH BELL CLUTCH BELL (FINNED RING)	7711207	7711207	-	7711207
		€33,45 Ø 107	€33,45 Ø 107		€33,45 Ø 107
	FLY SYSTEM CLUTCH BELL + NOT ADJUSTABLE CLUTCH	5214111	-	-	5214111
		€63,00 Ø 107			€63,00 Ø 107
	DELTA SYSTEM CLUTCH BELL + ADJUSTABLE CLUTCH	5214110	-	-	5214110
		€93,84 Ø 107			€93,84 Ø 107
	SPORT SPRINGS FOR FLY / DELTA CLUTCH	29 8746	-	-	29 8746
		€14,50			€14,50
	MHR SPRINGS FOR FLY / DELTA CLUTCH	29 8747	-	-	29 8747
		€19,40			€19,40
	SPRINGS Ø INTERNAL CLUTCH BELL 105-107 FOR ORIGINAL CLUTCH	29 9605	29 7454	29 7456	29 7454
	€16,20	€16,20 <-1996	€16,20	€16,20 <-1996	
	MUELLES Ø INTERNAL CLUTCH BELL 112 FOR ORIGINAL CLUTCH	-	29 9605	-	29 9605
			€16,20 1997->		€16,20 1997->

PEUGEOT

SPEEDFIGHT	SPEEDFIGHT	SPEEDFIGHT 2 2004->	SPEEDFIGHT 3	SPEEDFIGHT 3	SPEEDFIGHT	SQUAB	ST
			(B1E 40 QMB)				
50 2T	50 2T LC	50 2T LC	50 2T	50 2T LC	100 2T	50 2T	50 2T
31 8573 €124,91 Ø 40 (12)	31 9847 €218,14 Ø 40 (12)	31 9847 €218,14 Ø 40 (12)	3112904 €249,10 Ø 40 (12)	3112898 €249,10 Ø 40 (12)	-	31 8573 €124,91 Ø 40 (12)	-
31 7133 €123,02 Ø 47 (12)	-	-	-	3112893 €190,21 Ø 47 (12)	-	31 7133 €123,02 Ø 47 (12)	-
31 7132 €103,12 Ø 47 (12)	-	-	-	-	3111081 €254,42 Ø 55 (14)	31 7132 €103,12 Ø 47 (12)	31 6405 €95,21 Ø 47 (10)
38 7362 €37,45 Ø 47	-	-	-	-	-	38 7362 €37,45 Ø 47	38 7157 €39,02 Ø 47
31 8640 €201,34 Ø 47 (12)	31 9477 €242,80 Ø 47 (12)	31 9477 €242,80 Ø 47 (12)	3112901 €239,30 Ø 47 (12)	-	-	31 8640 €201,34 Ø 47 (12)	-
-	-	-	-	-	-	-	-
53 8619 €181,19	53 8619 €181,19	-	-	-	-	53 8619 €181,19	-
-	-	-	-	-	-	-	-
55 8132 €50,14	55 8132 €50,14	-	-	-	-	55 8132 €50,14	55 8132 €50,14
55 8675 €104,38	55 8675 €104,38	-	-	-	-	55 8675 €104,38	55 8675 €104,38
51 8752 €58,71	51 8752 €58,71	51 8752 €58,71	51 8752 €58,71	51 8752 €58,71	5111558 KAT €61,80 5111127 NO KAT €62,83	51 8752 €58,71	51 7073 €58,71
6112735 €15,46	6112735 €15,46	6112735 €15,46	6112735 €15,46	6112735 €15,46	-	6112735 €15,46	61 7213 €13,94
6112736 €27,23	6112736 €27,23	6112736 €27,23	6112736 €27,23	6112736 €27,23	6114118 €38,25 NO KAT	6112736 €27,23	-
66 9823.O0 €9,50 gr.09	66 9823.O0 €9,50 gr.09	66 9823.O0 €9,50 gr.09	66 9823.O0 €9,50 gr.09	66 9823.O0 €9,50 gr.09	66 9420.J0 gr.11 KAT €10,00 66 9420.P0 gr.09,3 NO KAT €10,00	66 9823.O0 €9,50 gr.09	66 9823.M0 €9,50 gr.07
66 9823.O0 €9,50 gr.09	66 9823.O0 €9,50 gr.09	66 9823.N0 €9,50 gr.08	66 9823.O0 €9,50 gr.09	-	-	66 9823.O0 €9,50 gr.09	66 9823.Q0 €9,50 gr.07,5
-	-	-	-	-	-	-	-
PG.438	PG.438	PG.438	PG.438	PG.438	-	PG.438	PG.438
2512828 €4,45	2512828 €4,45	2512828 €4,45	2512828 €4,45	2512828 €4,45	-	2512828 €4,45	2512828 €4,45
61 8317 €95,61	61 8317 €95,61	-	61 8317 €95,61	61 8317 €95,61	-	61 8317 €95,61	-
52 8797 €47,30	52 8797 €47,30	52 8797 €47,30	52 8797 €47,30	52 8797 €47,30	-	52 8797 €47,30	-
52 7880 €77,89	52 7880 €77,89	52 7880 €77,89	52 7880 €77,89	52 7880 €77,89	-	52 7880 €77,89	-
7711115 €22,60 Ø 107	7711115 €22,60 Ø 107	7711115 €22,60 Ø 107	7711115 €22,60 Ø 107	7711115 €22,60 Ø 107	-	7711115 €22,60 Ø 107	7711115 €22,60 Ø 107
7711207 €33,45 Ø 107	7711207 €33,45 Ø 107	7711207 €33,45 Ø 107	7711207 €33,45 Ø 107	7711207 €33,45 Ø 107	-	7711207 €33,45 Ø 107	7711207 €33,45 Ø 107
5214111 €63,00 Ø 107	5214111 €63,00 Ø 107	5214111 €63,00 Ø 107	5214111 €63,00 Ø 107	5214111 €63,00 Ø 107	-	5214111 €63,00 Ø 107	-
5214110 €93,84 Ø 107	5214110 €93,84 Ø 107	5214110 €93,84 Ø 107	5214110 €93,84 Ø 107	5214110 €93,84 Ø 107	-	5214110 €93,84 Ø 107	-
29 8746 €14,50	29 8746 €14,50	29 8746 €14,50	29 8746 €14,50	29 8746 €14,50	-	29 8746 €14,50	-
29 8747 €19,40	29 8747 €19,40	29 8747 €19,40	29 8747 €19,40	29 8747 €19,40	-	29 8747 €19,40	-
29 7454 €16,20 <-1996	29 7454 €16,20 <-1996	29 7454 €16,20	-	-	2911325 €17,24	29 7454 €16,20 <-1996	29 7454 €16,20 <-1996
29 9605 €16,20 1997->	29 9605 €16,20 1997->	-	-	-	-	29 9605 €16,20 1997->	29 9605 €16,20 1997->



MALOSSI

Scooter 2T

with ENGINE 

PEUGEOT

METAL-X

RAPIDO

SC L METROPOLIS

SPEEDAKE

50 2T



50 2T















50 2T

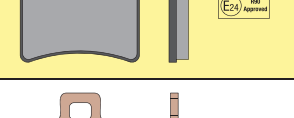
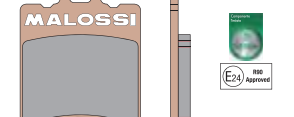

50 2T

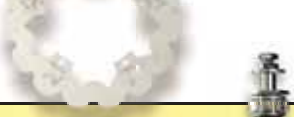
**() CHECK "TYPE" SPECIFICATION (HOMOLOGATION MARK)**

	CARBURETTOR		-	-	-	-
	CARBURETTOR KIT Ø 19	1611027	1611004	-	1611027	
		€ 125,27	€ 107,15		€ 125,27	
	CARBURETTOR KIT Ø 21	-	-	-	-	
	CARBURETTOR KIT Ø 22	-	-	-	-	
	REED VALVE CARBON FIBRE	27 7440.C0	27 7440.C0	27 7440.C0	27 7440.C0	
		€ 49,00 VL9	€ 49,00 VL9	€ 49,00 VL9	€ 49,00 VL9	
	PETALS SET FOR ORIGINAL REED VALVE	27 2728.C0	27 1423.C0	27 1090.C0	27 2728.C0	
		€ 16,27	€ 14,46	€ 14,90	€ 16,27	
	ART OF PERFORMANCE / FLIP HOMOLOGATED 	PG. 426	-	-	-	-
	WILD LION HOMOLOGATED 	PG. 424	-	-	-	-
	RED SPONGE FOR ORIGINAL AIR BOX	1411418	-	-	1411418	
		€ 3,12			€ 3,12	
	DOUBLE RED SPONGE FOR ORIGINAL AIR BOX	1414494	-	-	1414494	
		€ 5,87			€ 5,87	
	GEARS HTQ PRIMARY	67 8378	67 6458	67 6422	67 8378	
		€ 65,00 z 13/35	€ 65,00 z 16/32	€ 49,77 z 16/32	€ 65,00 z 13/35	
	GEARS HTQ SECONDARY	PG. 478	-	-	-	
	ROLLER CRANKCASE	-	-	-	-	
	SCREEN	-	-	-	-	
	BRAKE PADS FRONT	-	-	-	6215042	
	ORGANIC BRAKE PADS				€ 5,72 1995->	
	BRAKE PADS MHR FRONT	-	-	-	6215080	
ORGANIC BRAKE PADS				€ 6,00 1995->		
BRAKE PADS MHR SYNT FRONT	-	-	-	6215007		
SINTERED BRAKE PADS				€ 11,96 1995->		
	BRAKE PADS REAR	-	-	-	-	
	ORGANIC BRAKE PADS					
	BRAKE PADS MHR REAR	-	-	-	-	
ORGANIC BRAKE PADS						
BRAKE PADS MHR SYNT REAR	-	-	-	-		
SINTERED BRAKE PADS						
	BRAKE POWER REAR	-	6215899 € 20,00	6215899 € 20,00	6215802	
	BRAKE SHOES FRONT		6215899 € 20,00	6215802 € 18,64	€ 18,64 1995->	
	WHOOOP DISC FRONT	6212603	-	-	6212603	
	BRAKE DISC	€ 72,56			€ 72,56 1995->	
	WHOOOP DISC REAR	-	-	-	-	
	BRAKE DISC					
	RS1 - RS3 REAR SHOCK ABSORBER	46 7905	-	46 7905	4615433 € 90,78	
		€ 140,92		€ 140,92	46 8610 € 141,25	
	RS24 - RS24/10 FRONT SHOCK ABSORBER	-	-	-	-	
	RS24 - RS24/10 - RS24/10-R REAR SHOCK ABSORBER	46 7588	-	-	46 8611	
	€ 255,97			€ 219,76		
	RS24 FRONT + REAR	-	-	-	-	
	HORQUILLA F32S FORK STEMS Ø 32	-	-	-	-	
	HORQUILLA F37R MHR FORK STEMS Ø 37	-	-	-	-	

28 - ONLY FOR VEHICLES with AJP CALIPER

PEUGEOT

SPEEDFIGHT	SPEEDFIGHT	SPEEDFIGHT 2 2004->	SPEEDFIGHT 3	SPEEDFIGHT 3	SPEEDFIGHT	SQUAB	ST
			(B1E 40 QMB)				
50 2T	50 2T LC	50 2T LC	50 2T	50 2T LC	100 2T	50 2T	50 2T
-	-	-	-	-	-	-	-
1611027 € 125,27	1611027 € 125,27	1611027 € 125,27	-	-	-	1611027 € 125,27	1611004 € 107,15
-	-	-	-	1610995 € 114,23	1611126 € 114,23	-	-
-	-	-	-	-	-	-	-
27 7440.C0 € 49,00 VL9	27 7440.C0 € 49,00 VL9	27 7440.C0 € 49,00 VL9	-	-	-	27 7440.C0 € 49,00 VL9	27 7440.C0 € 49,00 VL9
27 2728.C0 € 16,27	27 2728.C0 € 16,27	-	27 7054.C0 € 18,71	27 7054.C0 € 18,71	-	27 2728.C0 € 16,27	27 1423.C0 € 14,46
3215184 € 120,00	3215184 € 120,00	-	-	-	-	-	-
-	-	-	-	-	-	-	-
1411418 € 3,12	1411418 € 3,12	1411418 € 3,12	-	-	-	1411418 € 3,12	-
1414494 € 5,87	1414494 € 5,87	1414494 € 5,87	-	-	-	1414494 € 5,87	-
67 8378 € 65,00 z 13/35	67 8378 € 65,00 z 13/35	67 8378 € 65,00 z 13/35	67 8378 € 65,00 z 13/35	67 8378 € 65,00 z 13/35	-	67 8378 € 65,00 z 13/35	67 6458 € 65,00 z 16/32
-	-	-	-	-	-	-	-
-	-	-	-	-	-	-	-
-	-	-	-	-	-	-	-
6215051 *28* € 5,72 1998->	6215051 *28* € 5,72 1998->	6215059 € 8,84	-	-	-	6215059 € 8,84 1996->	-
6215076 *28* € 6,24 1998->	6215076 *28* € 6,24 1998->	6212164 € 8,50	-	-	-	6212164 € 8,50 1996->	-
6215005 *28* € 11,96 1998->	6215005 *28* € 11,96 1998->	-	-	-	-	-	-
6215051 *28* € 5,72 1998->	6215051 *28* € 5,72 1998->	6215049 € 6,24	-	-	-	-	-
6215076 *28* € 6,24 1998->	6215076 *28* € 6,24 1998->	6215074 € 6,30	-	-	-	-	-
6215005 *28* € 11,96 1998->	6215005 *28* € 11,96 1998->	6215006 € 11,96	-	-	-	-	-
-	-	-	-	-	-	6215834 € 21,50 1996->	6215899 € 20,00 6215899 € 20,00
-	-	-	-	-	-	6212603 € 72,56 1996->	-
-	-	-	-	-	-	-	-
-	-	-	-	-	-	4615433 € 90,78 46 8610 € 141,25	-
-	-	-	-	-	-	-	-
-	-	-	46 8611 € 219,76	-	-	46 8611 € 219,76	-
-	-	-	-	-	-	-	-
-	-	-	-	-	-	-	-
-	-	-	-	-	-	-	-



MALOSSI

Scooter 2T

with ENGINE 

PEUGEOT

SV GEO

TREKKER

TREKKER

VIVACITY

50 2T



50 2T



100 2T



50 2T

**(▲) ATTENTION: ONLY FOR vehicles WITHOUT IMMOBILIZER KEY**

	CYLINDER+HEAD CAST-IRON Ø 40	31 8573	31 8573	-	31 8573
	(pin) ALUMINIUM Ø 40-41	€124,91 Ø 40 (12)	€124,91 Ø 40 (12)	-	€124,91 Ø 40 (12)
	CYLINDER+HEAD	31 7133	31 7133	-	31 7133
	(pin) CAST-IRON Ø 47	€123,02 Ø 47 (12)	€123,02 Ø 47 (12)	-	€123,02 Ø 47 (12)
	CYLINDER CAST-IRON Ø 47-57,5	31 7132	31 7132	3111081	31 7132
for ORIGINAL HEAD ALUM. Ø 47>57,5	€103,12 Ø 47 (12)	€103,12 Ø 47 (12)	€254,42 Ø 55 (14)	€103,12 Ø 47 (12)	
	HEAD HTSR	38 7362	38 7362	-	38 7362
	for Malossi CYLINDER	€37,45 Ø 47	€37,45 Ø 47	-	€37,45 Ø 47
	CYLINDER+HEAD MHR Replica ALUMINIUM	31 8640	31 8640	-	31 8640
	(pin) Ø 47	€201,34 Ø 47 (12)	€201,34 Ø 47 (12)	-	€201,34 Ø 47 (12)
	CRANKSHAFTS RHQ	-	-	-	-
	PIN Ø 10	-	-	-	-
	CRANKSHAFTS RHQ	53 8619	53 8619	-	53 8619
	PIN Ø 12	€181,19	€181,19	-	€181,19
	RADIAL ROLLER BEARING	-	-	-	-
	FOR CRANKSHAFT				
	ELECTRONIC CONTROLLER	55 8132	55 8132	-	55 8132
		€50,14	€50,14	-	€50,14
	ELECTRONIC CONTROLLER	55 8675	55 8675	-	55 8675
	RPM CONTROL	€104,38	€104,38	-	€104,38
	MULTIVAR	51 7117	51 8752	5111558 KAT €61,80	51 8752
	VARIATOR	€58,71	€58,71	5111127 NO KAT €62,83	€58,71
	X SPECIAL BELT	61 8396	6112735	-	6112735
	BELT	€14,68	€15,46	-	€15,46
	X K BELT	61 7221	6112736	6114118	6112736
	BELT	€24,41	€27,23	€38,25 NO KAT	€27,23
	HTRoll	66 9823.NO	66 9823.O0	-	66 9823.O0
	ROLLERS FOR MULTIVAR	€9,50 gr.08	€9,50 gr.09	-	€9,50 gr.09
	HTRoll	66 9823.R0	66 9823.R0	-	66 9823.R0
	ROLLERS FOR ORIGINAL VARIATOR	€9,50 gr.08,5	€9,50 gr.08,5	-	€9,50 gr.08,5
	VENTILVAR	-	-	-	-
	FIXED HALF-PULLEY	-	-	-	-
	VARIABLE-SPEED DRIVE ADJUSTER SPRING	PG.438	PG.438	-	PG.438
	FOR VARIATOR				
	TORSION CONTROLLER	2512828	2512828	-	2512828
	ANTIFRICTION FIFTH WHEEL	€4,45	€4,45	-	€4,45
	TORQUE DRIVER	61 8317	61 8317	-	61 8317
	MOBILE DRIVEN SPLIT PULLEY	€95,61	€95,61	-	€95,61
	FLY CLUTCH	52 8797	52 8797	-	52 8797
	NOT ADJUSTABLE CLUTCH	€47,30	€47,30	-	€47,30
	DELTA CLUTCH	52 7880	52 7880	-	52 7880
	ADJUSTABLE CLUTCH	€77,89	€77,89	-	€77,89
	CLUTCH BELL	7711115	7711115	-	7711115
	CLUTCH BELL (SMOOTH RING)	€22,60 Ø 107	€22,60 Ø 107	-	€22,60 Ø 107
	WING CLUTCH BELL	7711207	7711207	-	7711207
	CLUTCH BELL (FINNED RING)	€33,45 Ø 107	€33,45 Ø 107	-	€33,45 Ø 107
	FLY SYSTEM	5214111	5214111	-	5214111
	CLUTCH BELL + NOT ADJUSTABLE CLUTCH	€63,00 Ø 107	€63,00 Ø 107	-	€63,00 Ø 107
	DELTA SYSTEM	5214110	5214110	-	5214110
	CLUTCH BELL + ADJUSTABLE CLUTCH	€93,84 Ø 107	€93,84 Ø 107	-	€93,84 Ø 107
	SPORT SPRINGS	29 8746	29 8746	-	29 8746
	FOR FLY / DELTA CLUTCH	€14,50	€14,50	-	€14,50
	MHR SPRINGS	29 8747	29 8747	-	29 8747
	FOR FLY / DELTA CLUTCH	€19,40	€19,40	-	€19,40
	SPRINGS Ø INTERNAL CLUTCH BELL 105-107	29 7454	29 7454	2911325	29 9605
FOR ORIGINAL CLUTCH	€16,20 <-1996	€16,20 <-1996	€17,24	€16,20	
MUELLES Ø INTERNAL CLUTCH BELL 112	29 9605	29 9605	-	-	
FOR ORIGINAL CLUTCH	€16,20 1997->	€16,20 1997->	-	-	

PG - SPECIFICATIONS on the PAGE indicated in the TITLE of the LINE

PEUGEOT							PGO
VIVACITY COMPACT	VIVACITY	X-FIGHT	X-FIGHT	X-FIGHT 2 2004->	X-FIGHT	ZENITH	RATTLER
(FB2FP)							
50 2T	100 2T	50 2T	50 2T	50 2T	50 2T	100 2T	110 2T
31 8573 €124,91 Ø 40 (12)	-	31 8573 €124,91 Ø 40 (12)	31 9847 €218,14 Ø 40 (12)	31 9847 €218,14 Ø 40 (12)	-	31 8573 €124,91 Ø 40 (12)	-
31 7133 €123,02 Ø 47 (12)	-	31 7133 €123,02 Ø 47 (12)	-	-	-	31 7133 €123,02 Ø 47 (12)	-
31 7132 €103,12 Ø 47 (12)	3111081 €254,42 Ø 55 (14)	31 7132 €103,12 Ø 47 (12)	-	-	3111081 €254,42 Ø 55 (14)	31 7132 €103,12 Ø 47 (12)	-
38 7362 €37,45 Ø 47	-	38 7362 €37,45 Ø 47	-	-	-	38 7362 €37,45 Ø 47	-
31 8640 €201,34 Ø 47 (12)	-	31 8640 €201,34 Ø 47 (12)	31 9477 €242,80 Ø 47 (12)	31 9477 €242,80 Ø 47 (12)	-	31 8640 €201,34 Ø 47 (12)	-
-	-	-	-	-	-	-	-
53 8619 €181,19	-	53 8619 €181,19	53 8619 €181,19	-	-	53 8619 €181,19	-
-	-	-	-	-	-	-	-
-	-	55 8132 €50,14	55 8132 €50,14	-	-	55 8132 €50,14	-
-	-	55 8675 €104,38	55 8675 €104,38	-	-	55 8675 €104,38	-
51 8752 €58,71	5111558 KAT €61,80 5111127 NO KAT €62,83	51 8752 €58,71	51 8752 €58,71	51 8752 €58,71	5111558 €61,80 KAT	51 8752 €58,71	5113591 €65,00
6112735 €15,46	-	6112735 €15,46	6112735 €15,46	6112735 €15,46	-	61 8396 €14,68	-
6112736 €27,23	6114118 €38,25 NO KAT	6112736 €27,23	6112736 €27,23	6112736 €27,23	-	61 7221 €24,41	-
66 9823.OO €9,50 gr.09	66 9420.JO gr.11 KAT €10,00 66 9420.PO gr.09,3 NO KAT €10,00	66 9823.OO €9,50 gr.09	66 9823.OO €9,50 gr.09	66 9823.OO €9,50 gr.09	66 9420.JO €10,00 gr.11	66 9823.OO €9,50 gr.09	66 9420.KO €10,00 gr.12
66 9823.NO €9,50 gr.08	-	66 9823.OO €9,50 gr.09	66 9823.OO €9,50 gr.09	66 9823.NO €9,50 gr.08	-	66 9823.R0 €9,50 gr.08,5	-
-	-	-	-	-	-	-	-
PG.438	-	PG.438	PG.438	PG.438	-	PG.438	2911266.Y0 *PG* €10,71
2512828 €4,45	-	2512828 €4,45	2512828 €4,45	2512828 €4,45	-	2512828 €4,45	-
61 8317 €95,61	-	61 8317 €95,61	61 8317 €95,61	-	-	61 8317 €95,61	-
52 8797 €47,30	-	52 8797 €47,30	52 8797 €47,30	52 8797 €47,30	-	52 8797 €47,30	-
52 7880 €77,89	-	52 7880 €77,89	52 7880 €77,89	52 7880 €77,89	-	52 7880 €77,89	-
7711115 €22,60 Ø 107	-	7711115 €22,60 Ø 107	7711115 €22,60 Ø 107	7711115 €22,60 Ø 107	-	7711115 €22,60 Ø 107	-
7711207 €33,45 Ø 107	-	7711207 €33,45 Ø 107	7711207 €33,45 Ø 107	7711207 €33,45 Ø 107	-	7711207 €33,45 Ø 107	-
5214111 €63,00 Ø 107	-	5214111 €63,00 Ø 107	5214111 €63,00 Ø 107	5214111 €63,00 Ø 107	-	5214111 €63,00 Ø 107	-
5214110 €93,84 Ø 107	-	5214110 €93,84 Ø 107	5214110 €93,84 Ø 107	5214110 €93,84 Ø 107	-	5214110 €93,84 Ø 107	-
29 8746 €14,50	-	29 8746 €14,50	29 8746 €14,50	29 8746 €14,50	-	29 8746 €14,50	-
29 8747 €19,40	-	29 8747 €19,40	29 8747 €19,40	29 8747 €19,40	-	29 8747 €19,40	-
29 9605 €16,20	2911325 €17,24	29 9605 €16,20	-	29 7454 €16,20	2911325 €17,24	29 7454 €16,20 <-1996	-
-	-	-	-	-	-	29 9605 €16,20 1997->	-



MALOSSI

Scooter 2T

with ENGINE 

PEUGEOT

SV GEO

TREKKER

TREKKER

VIVACITY

50 2T



50 2T

















100 2T



50 2T



CHECK "TYPE" SPECIFICATION (HOMOLOGATION MARK)		50 2T	50 2T	100 2T	50 2T
	CARBURETTOR	-	-	-	-
	CARBURETTOR KIT Ø 19	1611000 € 115,95	1611027 € 125,27	-	1611027 € 125,27
	CARBURETTOR KIT Ø 21	-	-	1611126 € 114,23	-
	CARBURETTOR KIT Ø 22	-	-	-	-
	REED VALVE CARBON FIBRE	27 7440.C0 € 49,00 VL9	27 7440.C0 € 49,00 VL9	-	27 7440.C0 € 49,00 VL9
	PETALS SET FOR ORIGINAL REED VALVE	27 2728.C0 € 16,27	27 2728.C0 € 16,27	-	27 2728.C0 € 16,27
	ART OF PERFORMANCE / FLIP HOMOLOGATED  	PG. 426 -	-	-	-
	WILD LION HOMOLOGATED 	PG. 424 -	3216584 € 87,00	-	3216584 € 87,00
	RED SPONGE FOR ORIGINAL AIR BOX	-	1411418 € 3,12	-	1411418 € 3,12
	DOUBLE RED SPONGE FOR ORIGINAL AIR BOX	-	1414494 € 5,87	-	1414494 € 5,87
	GEARS HTQ PRIMARY	67 7121 € 37,81 z 15/33	67 8378 € 65,00 z 13/35	-	67 8378 € 65,00 z 13/35
	GEARS HTQ SECONDARY	PG. 478 -	-	-	-
	ROLLER CRANKCASE	-	-	-	-
	SCREEN	-	-	-	-
	BRAKE PADS FRONT	6215065 € 10,40 1992->	6215059 € 8,84 1997->	6215051 € 5,72 1998->	6215051 € 5,72 1998->
	BRAKE PADS MHR FRONT	62 9086 € 10,17 1992->	6212164 € 8,50 1997->	6215076 € 6,24 1998->	6215076 € 6,24 1998->
	BRAKE PADS MHR SYNT FRONT	-	-	6215005 € 11,96 1998->	6215005 € 11,96 1998->
	BRAKE PADS REAR	-	-	-	-
	BRAKE PADS MHR REAR	-	-	-	-
	BRAKE PADS MHR SYNT REAR	-	-	-	-
	BRAKE POWER REAR	6215802	6215834	-	-
	BRAKE SHOES FRONT	€ 18,64 1992->	€ 21,50 1997->	-	-
	WHOOOP DISC FRONT	-	6212603 € 72,56 1997->	-	-
	WHOOOP DISC REAR	-	-	-	-
	RS1 - RS3 REAR SHOCK ABSORBER	46 7906 € 140,92	4615433 € 90,78 46 8610 € 141,25	-	-
	RS24 - RS24/10 FRONT SHOCK ABSORBER	-	-	-	-
	RS24 - RS24/10 - RS24/10-R REAR SHOCK ABSORBER	46 7589 € 221,96	46 8611 € 219,76	-	-
	RS24 FRONT + REAR	-	-	-	-
	HORQUILLA F32S FORK STEMS Ø 32	-	-	-	-
	HORQUILLA F37R MHR FORK STEMS Ø 37	-	-	-	-

28 - ONLY FOR VEHICLES with AJP CALIPER

PEUGEOT							PGO
VIVACITY COMPACT	VIVACITY	X-FIGHT	X-FIGHT	X-FIGHT 2 2004->	X-FIGHT	ZENITH	RATTLER
(FB2FP)							
50 2T	100 2T	50 2T	50 2T LC	50 2T LC	100 2T	50 2T	110 2T
-	-	-	-	-	-	-	-
1611027 € 125,27	-	1611027 € 125,27	1611027 € 125,27	1611027 € 125,27	-	1611027 € 125,27	-
-	1611126 € 114,23	-	-	-	1611126 € 114,23	-	-
-	-	-	-	-	-	-	-
27 7440.C0 € 49,00 VL9	-	27 7440.C0 € 49,00 VL9	27 7440.C0 € 49,00 VL9	27 7440.C0 € 49,00 VL9	-	27 7440.C0 € 49,00 VL9	-
27 2728.C0 € 16,27	-	27 2728.C0 € 16,27	27 2728.C0 € 16,27	-	-	27 2728.C0 € 16,27	-
-	-	-	-	-	-	-	-
-	-	-	-	-	-	-	-
1411418 € 3,12	-	1411418 € 3,12	1411418 € 3,12	1411418 € 3,12	-	1411418 € 3,12	-
1414494 € 5,87	-	1414494 € 5,87	1414494 € 5,87	1414494 € 5,87	-	1414494 € 5,87	-
67 8378 € 65,00 z 13/35	-	67 8378 € 65,00 z 13/35	67 8378 € 65,00 z 13/35	67 8378 € 65,00 z 13/35	-	67 7121 € 37,81 z 15/33	-
-	-	-	-	-	-	-	-
-	-	-	-	-	-	-	-
-	-	-	-	-	-	-	-
6215051 € 5,72 1998->	6215051 € 5,72 1998->	6215051 *28* € 5,72 2000->	6215051 *28* € 5,72 2000->	6215059 € 8,84	6215051 € 5,72 2000->	6215051 € 5,72 1996->	-
6215076 € 6,24 1998->	6215076 € 6,24 1998->	6215076 *28* € 6,24 2000->	6215076 *28* € 6,24 2000->	6212164 € 8,50	6215076 € 6,24 2000->	6215076 € 6,24 1996->	-
6215005 € 11,96 1998->	6215005 € 11,96 1998->	6215005 *28* € 11,96 2000->	6215005 *28* € 11,96 2000->	-	6215005 € 11,96 2000->	6215005 € 11,96 1996->	-
-	-	-	6215051 *28* € 5,72 2000->	6215049 € 6,24	-	-	-
-	-	-	6215076 *28* € 6,24 2000->	6215074 € 6,30	-	-	-
-	-	-	6215005 *28* € 11,96 2000->	6215006 € 11,96	-	-	-
-	-	-	-	-	-	6215802 € 18,64 1996->	-
6212603 € 72,56	-	-	-	-	-	62 8958 € 59,03 1996->	-
-	-	-	-	-	-	-	-
4615433 € 90,78 46 8610 € 141,25	-	-	46 7905 € 140,92	-	-	4615434 € 88,74	-
-	-	-	-	-	-	-	-
46 8611 € 219,76	-	-	46 7588 € 255,97	-	-	46 7589 € 221,96	-
-	-	-	-	-	-	-	-
-	-	-	-	-	-	-	-
-	-	-	-	-	-	-	-



MALOSSI

Scooter 2T

with ENGINE 

PIAGGIO

DIESIS

FLY

FREE

LIBERTY

50 2T



50 2T



50 2T





50 2T

**(▲) ATTENTION: ONLY FOR vehicles WITHOUT IMMOBILIZER KEY**

	CYLINDER+HEAD CAST-IRON Ø 40	31 8520	31 8520	31 8520	31 8520
	(pin) ALUMINIUM Ø 40-41	€ 124,91 Ø 40 (12)	€ 124,91 Ø 40 (12)	€ 124,91 Ø 40 (12)	€ 124,91 Ø 40 (12)
	CYLINDER+HEAD	31 6926	31 6926	31 6926	31 6926
	(pin) CAST-IRON Ø 47	€ 120,25 Ø 47 (12)	€ 120,25 Ø 47 (12)	€ 120,25 Ø 47 (12)	€ 120,25 Ø 47 (12)
	CYLINDER CAST-IRON Ø 47-57,5	31 6915	31 6915	31 6915	31 6915
for ORIGINAL HEAD ALUM. Ø 47>57,5	€ 100,86 Ø 47 (12)	€ 100,86 Ø 47 (12)	€ 100,86 Ø 47 (12)	€ 100,86 Ø 47 (12)	
	HEAD HTSR	38 7118	38 7118	38 7118	38 7118
	for Malossi CYLINDER	€ 37,45 Ø 47	€ 37,45 Ø 47	€ 37,45 Ø 47	€ 37,45 Ø 47
	CYLINDER+HEAD MHR Replica ALUMINIUM	31 8463	31 8463	31 8463	31 8463
	(pin) Ø 47	€ 207,00 Ø 47 (12)	€ 207,00 Ø 47 (12)	€ 207,00 Ø 47 (12)	€ 207,00 Ø 47 (12)
	CRANKSHAFTS RHQ	-	-	-	-
	PIN Ø 10				
	CRANKSHAFTS RHQ	53 7600	53 7600	53 7600	53 7600
	PIN Ø 12	€ 175,50	€ 175,50	€ 175,50	€ 175,50
	RADIAL ROLLER BEARING	6614105E	6614105E	6614105E	6614105E
	FOR CRANKSHAFT	€ 43,00	€ 43,00	€ 43,00	€ 43,00
	ELECTRONIC CONTROLLER	5513195 *35*	5513195 *35*	5513195 *35*	5513195 *35*
		€ 92,82	€ 92,82	€ 92,82	€ 92,82
	ELECTRONIC CONTROLLER	5513196 *35*	5513196 *35*	5513196 *35*	5513196 *35*
	RPM CONTROL	€ 140,51	€ 140,51	€ 140,51	€ 140,51
	MULTIVAR	51 9019	51 9019	51 9019 2001-> € 61,80	51 9019 € 61,80
	VARIATOR	€ 61,80	€ 61,80	51 7382 <-2000 € 58,71	51 9448 1997 € 60,00
	X SPECIAL BELT	61 9831	61 9831	61 9831 2001-> € 19,49	61 9830
	BELT	€ 19,49	€ 19,49	61 9832 <-2000 € 17,04	€ 17,34
	X K BELT	6114118	6114118	61 7587 <-2000 € 28,25	61 9535
	BELT	€ 38,25	€ 38,25	6114118 2001-> € 38,25	€ 28,72
	HTRoll	66 9420.M0	66 9420.M0	66 9420.M0 gr.07,2 2001-> € 10,00	66 9420.M0
	ROLLERS FOR MULTIVAR	€ 10,00 gr.07,2	€ 10,00 gr.07,2	66 9823.NO gr.08 <-2000 € 9,50	€ 10,00 gr.07,2
	HTRoll	66 9420.NO	66 9420.NO	66 9420.NO gr.07,5 2001-> € 10,00	66 9420.I0
	ROLLERS FOR ORIGINAL VARIATOR	€ 10,00 gr.07,5	€ 10,00 gr.07,5	66 9823.R0 gr.08,5 <-2000 € 9,50	€ 10,00 gr.06,5
	VENTILVAR	-	-	-	-
	FIXED HALF-PULLEY				
	VARIABLE-SPEED DRIVE ADJUSTER SPRING	PG.438	PG.438	PG.438	PG.438
	FOR VARIATOR				
	TORSION CONTROLLER	2512828	2512828	2512828	2512828
	ANTIFRICTION FIFTH WHEEL	€ 4,45	€ 4,45	€ 4,45	€ 4,45
	TORQUE DRIVER	61 9100	61 9100	61 8233 <-2000 € 85,57	61 9100
	MOBILE DRIVEN SPLIT PULLEY	€ 85,57	€ 85,57	61 9223 2001-> € 85,57	€ 85,57
	FLY CLUTCH	52 8797	52 8797	52 8797	52 8797
	NOT ADJUSTABLE CLUTCH	€ 47,30	€ 47,30	€ 47,30	€ 47,30
	DELTA CLUTCH	52 7880	52 7880	52 7880	52 7880
	ADJUSTABLE CLUTCH	€ 77,89	€ 77,89	€ 77,89	€ 77,89
	CLUTCH BELL	7711115	7711115	7711115	7711115
	CLUTCH BELL (SMOOTH RING)	€ 22,60 Ø 107	€ 22,60 Ø 107	€ 22,60 Ø 107	€ 22,60 Ø 107
	WING CLUTCH BELL	7711207	7711207	7711207	7711207
	CLUTCH BELL (FINNED RING)	€ 33,45 Ø 107	€ 33,45 Ø 107	€ 33,45 Ø 107	€ 33,45 Ø 107
	FLY SYSTEM	5214111	5214111	5214111	5214111
	CLUTCH BELL + NOT ADJUSTABLE CLUTCH	€ 63,00 Ø 107	€ 63,00 Ø 107	€ 63,00 Ø 107	€ 63,00 Ø 107
	DELTA SYSTEM	5214110	5214110	5214110	5214110
	CLUTCH BELL + ADJUSTABLE CLUTCH	€ 93,84 Ø 107	€ 93,84 Ø 107	€ 93,84 Ø 107	€ 93,84 Ø 107
	SPORT SPRINGS	29 8746	29 8746	29 8746	29 8746
	FOR FLY / DELTA CLUTCH	€ 14,50	€ 14,50	€ 14,50	€ 14,50
	MHR SPRINGS	29 8747	29 8747	29 8747	29 8747
	FOR FLY / DELTA CLUTCH	€ 19,40	€ 19,40	€ 19,40	€ 19,40
	SPRINGS Ø INTERNAL CLUTCH BELL 105-107	29 7454	29 7454	29 7454	29 7454
	FOR ORIGINAL CLUTCH	€ 16,20	€ 16,20	€ 16,20	€ 16,20
	MUELLES Ø INTERNAL CLUTCH BELL 112	-	-	-	-
	FOR ORIGINAL CLUTCH				

35 - IT CAN BE ASSEMBLED WITH NO MODIFICATION to the original system, EVEN ON vehicles PRODUCED 2001->

PIAGGIO

NRG	NRG EXTREME	NRG EXTREME	NRG MC2 <-1997	NRG MC2 1998->	NRG MC3 DD	NRG MC3 DT	NRG MC3 Purejet
50 2T LC	50 2T 	50 2T LC	50 2T LC	50 2T LC	50 2T LC	50 2T 	50 2T LC
31 8523 €164,21 Ø 40 (12)	31 8520 €124,91 Ø 40 (12)	31 8523 €164,21 Ø 40 (12)	31 8523 €164,21 Ø 40 (12)	31 8523 €164,21 Ø 40 (12)	31 8523 €164,21 Ø 40 (12)	31 8520 €124,91 Ø 40 (12)	-
31 7353 €176,03 Ø 47 (12)	31 6926 €120,25 Ø 47 (12)	31 7353 €176,03 Ø 47 (12)	31 7353 €176,03 Ø 47 (12)	31 7353 €176,03 Ø 47 (12)	31 7353 €176,03 Ø 47 (12)	31 6926 €120,25 Ø 47 (12)	3112044 €305,23 Ø 47 (12)
-	31 6915 €100,86 Ø 47 (12)	-	-	-	-	31 6915 €100,86 Ø 47 (12)	-
-	38 7118 €37,45 Ø 47	-	-	-	-	38 7118 €37,45 Ø 47	-
31 8466 €239,46 Ø 47 (12)	31 8463 €207,00 Ø 47 (12)	31 8466 €239,46 Ø 47 (12)	31 8466 €239,46 Ø 47 (12)	31 8466 €239,46 Ø 47 (12)	31 8466 €239,46 Ø 47 (12)	31 8463 €207,00 Ø 47 (12)	-
-	-	-	-	-	-	-	-
53 7600 €175,50	53 7600 €175,50	53 7600 €175,50	53 7600 €175,50	53 7600 €175,50	53 7600 €175,50	53 7600 €175,50	5312331 €301,56
6614105E €43,00	6614105E €43,00	6614105E €43,00	6614105E €43,00	6614105E €43,00	6614105E €43,00	6614105E €43,00	-
5513195 *35* €92,82	5513195 *35* €92,82	5513195 *35* €92,82	5513195 *35* €92,82	5513195 *35* €92,82	5513195 *35* €92,82	5513195 *35* €92,82	PG.422
5513196 *35* €140,51	5513196 *35* €140,51	5513196 *35* €140,51	5513196 *35* €140,51	5513196 *35* €140,51	5513196 *35* €140,51	5513196 *35* €140,51	-
51 7382 €58,71	51 9019 €61,80 51 9448 1997 €60,00	51 9019 €61,80 51 9448 1997 €60,00	51 7382 €58,71	51 9019 €61,80 51 9448 1997 €60,00	51 9019 €61,80	51 9019 €61,80	51 9019 €61,80
61 9832 €17,04	61 9831 €19,49	61 9831 €19,49	61 9832 €17,04	61 9831 €19,49	61 9831 €19,49	61 9831 €19,49	61 9831 €19,49
61 7587 €28,25	6114118 €38,25	6114118 €38,25	61 7587 €28,25	6114118 €38,25	6114118 €38,25	6114118 €38,25	6114118 €38,25
66 9823.NO €9,50 gr.08	66 9420.M0 €10,00 gr.07,2	66 9420.M0 €10,00 gr.07,2	66 9823.NO €9,50 gr.08	66 9420.M0 €10,00 gr.07,2	66 9420.M0 €10,00 gr.07,2	66 9420.M0 €10,00 gr.07,2	66 9420.M0 €10,00 gr.07,2
66 9823.R0 €9,50 gr.08,5	66 9420.I0 €10,00 gr.06,5	66 9420.I0 €10,00 gr.06,5	66 9823.M0 €9,50 gr.07 <-1997	66 9420.I0 €10,00 gr.06,5	66 9420.N0 €10,00 gr.07,5	66 9420.N0 €10,00 gr.07,5	-
-	-	-	-	-	-	-	-
PG.438	PG.438	PG.438	PG.438	PG.438	PG.438	PG.438	-
2512828 €4,45	2512828 €4,45	2512828 €4,45	2512828 €4,45	2512828 €4,45	2512828 €4,45	2512828 €4,45	2512828 €4,45
61 8233 €85,57	61 9100 €85,57	61 9100 €85,57	61 8233 €85,57	61 9100 €85,57	61 9100 €85,57	61 9100 €85,57	61 9100 €85,57
52 8797 €47,30	52 8797 €47,30	52 8797 €47,30	52 8797 €47,30	52 8797 €47,30	52 8797 €47,30	52 8797 €47,30	52 8797 €47,30
52 7880 €77,89	52 7880 €77,89	52 7880 €77,89	52 7880 €77,89	52 7880 €77,89	52 7880 €77,89	52 7880 €77,89	52 7880 €77,89
7711115 €22,60 Ø 107	7711115 €22,60 Ø 107	7711115 €22,60 Ø 107	7711115 €22,60 Ø 107	7711115 €22,60 Ø 107	7711115 €22,60 Ø 107	7711115 €22,60 Ø 107	7711115 €22,60 Ø 107
7711207 €33,45 Ø 107	7711207 €33,45 Ø 107	7711207 €33,45 Ø 107	7711207 €33,45 Ø 107	7711207 €33,45 Ø 107	7711207 €33,45 Ø 107	7711207 €33,45 Ø 107	7711207 €33,45 Ø 107
5214111 €63,00 Ø 107	5214111 €63,00 Ø 107	5214111 €63,00 Ø 107	5214111 €63,00 Ø 107	5214111 €63,00 Ø 107	5214111 €63,00 Ø 107	5214111 €63,00 Ø 107	5214111 €63,00 Ø 107
5214110 €93,84 Ø 107	5214110 €93,84 Ø 107	5214110 €93,84 Ø 107	5214110 €93,84 Ø 107	5214110 €93,84 Ø 107	5214110 €93,84 Ø 107	5214110 €93,84 Ø 107	5214110 €93,84 Ø 107
29 8746 €14,50	29 8746 €14,50	29 8746 €14,50	29 8746 €14,50	29 8746 €14,50	29 8746 €14,50	29 8746 €14,50	29 8746 €14,50
29 8747 €19,40	29 8747 €19,40	29 8747 €19,40	29 8747 €19,40	29 8747 €19,40	29 8747 €19,40	29 8747 €19,40	29 8747 €19,40
29 7454 €16,20	29 7454 €16,20	29 7454 €16,20	29 7454 €16,20	29 7454 €16,20	29 7454 €16,20	29 7454 €16,20	-
-	-	-	-	-	-	-	-



MALOSSI

Scooter 2T

with ENGINE 

PIAGGIO

DIESIS

FLY

FREE

LIBERTY

50 2T



50 2T















50 2T

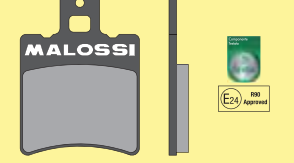
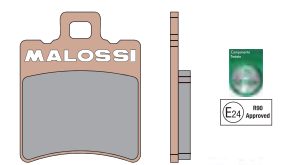

50 2T

**(■) CHECK "TYPE" SPECIFICATION (HOMOLOGATION MARK)**

	CARBURETTOR		72 7084 € 75,17 Ø 17,5	72 7084 € 75,17 Ø 17,5	72 7084 € 75,17 Ø 17,5	72 7084 € 75,17 Ø 17,5
	CARBURETTOR KIT	Ø 19	1611040 € 118,04	1611040 € 118,04	1611042 € 118,04	1611042 € 118,04
	CARBURETTOR KIT	Ø 21	1610997 € 114,23	1610997 € 114,23	1610995 € 114,23	1610995 € 114,23
	CARBURETTOR KIT	Ø 22	1611029 € 96,77	1611029 € 96,77	1611029 € 96,77	1611029 € 96,77
	REED VALVE CARBON FIBRE		27 7708.CO € 48,95 VL11	27 7708.CO € 48,95 VL11	27 7708.CO € 48,95 VL11	27 7708.CO € 48,95 VL11
	PETALS SET FOR ORIGINAL REED VALVE		27 7054.CO € 18,71	27 7054.CO € 18,71	27 7054.CO € 18,71	27 7054.CO € 18,71
	ART OF PERFORMANCE / FLIP HOMOLOGATED 	PG. 426	-	-	-	3215167 € 175,70 3216692 € 122,00
	WILD LION HOMOLOGATED 	PG. 424	-	-	-	3216589 € 87,00
	RED SPONGE FOR ORIGINAL AIR BOX		-	-	-	1411419 € 4,76
	DOUBLE RED SPONGE FOR ORIGINAL AIR BOX		-	-	-	1414501 € 6,25
	GEARS HTQ PRIMARY		67 9080 z 14/39 € 60,41 6713339 z 15/38 € 61,71	67 9080 z 14/39 € 60,41 6713339 z 15/38 € 61,71	67 8218 z14/39 (18) € 56,53 67 8220 (17) € 56,53	-
	GEARS HTQ SECONDARY	PG. 478	67 9966 € 65,00 z 13/48	67 9966 € 65,00 z 13/48	PG.478	6711135 *PG* € 58,86 z15/55 (17)
	ROLLER CRANKCASE		2514521 *66* € 95,00	2514521 *66* € 95,00	2514521 *66* € 95,00 2001->	2514521 *66* € 95,00
	SCREEN		-	-	-	-
	BRAKE PADS FRONT		-	-	6215050 € 6,24 1995->	6215049 € 6,24 1997->
	BRAKE PADS MHR FRONT		-	-	62 9841 € 6,10 1995->	6215074 € 6,30 1997->
	BRAKE PADS MHR SYNT FRONT		-	-	-	6215006 € 11,96 1997->
	BRAKE PADS REAR		-	-	-	-
	BRAKE PADS MHR REAR		-	-	-	-
	BRAKE PADS MHR SYNT REAR		-	-	-	-
	BRAKE POWER REAR		-	-	6215806 1995-> € 15,00	-
	BRAKE SHOES FRONT		-	-	62 7843 <-1994 € 15,44	-
	WHOOP DISC FRONT		-	-	-	-
	WHOOP DISC REAR		-	-	-	-
	RS1 - RS3 REAR SHOCK ABSORBER		-	-	4615432 € 94,86 46 7908 € 140,92	4615432 € 94,86 46 7908 € 140,92
	RS24 - RS24/10 FRONT SHOCK ABSORBER		-	-	-	-
	RS24 - RS24/10 - RS24/10-R REAR SHOCK ABSORBER		-	-	46 8308 € 248,50 4614237 € 428,82	46 8308 € 248,50 4614237 € 428,82
	RS24 FRONT + REAR		-	-	-	-
	HORQUILLA F32S FORK STEMS Ø 32		-	-	-	-
	HORQUILLA F37R MHR FORK STEMS Ø 37		-	-	-	-

66 - NOT to be used on VEHICLE WITH ORIGINAL PRIMARY GEARS

PG - SPECIFICATIONS on the PAGE indicated in the TITLE of the LINE



MALOSSI

Scooter 2T

with ENGINE 

PIAGGIO

NRG Power DD

NRG Power DT

NRG Power
Purejet

NTT

(C453M)

50 2T

LC

50 2T



50 2T

LC

50 2T

LC

(▲) ATTENTION: ONLY FOR vehicles WITHOUT IMMOBILIZER KEY

	CYLINDER+HEAD CAST-IRON Ø 40	31 8523	31 8520	-	31 8523
	(pin) ALUMINIUM Ø 40-41	€ 164,21 Ø 40 (12)	€ 124,91 Ø 40 (12)	-	€ 164,21 Ø 40 (12)
	CYLINDER+HEAD	31 7353	31 6926	3112044	31 7353
	(pin) CAST-IRON Ø 47	€ 176,03 Ø 47 (12)	€ 120,25 Ø 47 (12)	€ 305,23 Ø 47 (12)	€ 176,03 Ø 47 (12)
	CYLINDER CAST-IRON Ø 47-57,5	-	31 6915	-	-
for ORIGINAL HEAD ALUM. Ø 47>57,5	-	€ 100,86 Ø 47 (12)	-	-	
HEAD HTSR	-	38 7118	-	-	
for Malossi CYLINDER	-	€ 37,45 Ø 47	-	-	
CYLINDER+HEAD MHR Replica ALUMINIUM	31 8466	31 8463	-	31 8466	
(pin) Ø 47	€ 239,46 Ø 47 (12)	€ 207,00 Ø 47 (12)	-	€ 239,46 Ø 47 (12)	
	CRANKSHAFTS RHQ	-	-	-	-
	PIN Ø 10	-	-	-	-
	CRANKSHAFTS RHQ	53 7600	53 7600	5312331	53 7600
	PIN Ø 12	€ 175,50	€ 175,50	€ 301,56	€ 175,50
	RADIAL ROLLER BEARING	6614105E	6614105E	6614105E	6614105E
	FOR CRANKSHAFT	€ 43,00	€ 43,00	€ 43,00	€ 43,00
	ELECTRONIC CONTROLLER	5513195 *35*	5513195 *36*	PG.418	5513195 *35*
		€ 92,82	€ 92,82	-	€ 92,82
	ELECTRONIC CONTROLLER	5513196 *35*	5513196 *36*	-	5513196 *35*
	RPM CONTROL	€ 140,51	€ 140,51	-	€ 140,51
	MULTIVAR	51 9019	51 9019	51 9019	51 7382
	VARIATOR	€ 61,80	€ 61,80	€ 61,80	€ 58,71
	X SPECIAL BELT	61 9831	61 9831	61 9831	61 9832
	BELT	€ 19,49	€ 19,49	€ 19,49	€ 17,04
	X K BELT	6114118	6114118	6114118	61 7587
BELT	€ 38,25	€ 38,25	€ 38,25	€ 28,25	
HTRoll	66 9420.M0	66 9420.M0	66 9420.M0	66 9823.N0	
ROLLERS FOR MULTIVAR	€ 10,00 gr.07,2	€ 10,00 gr.07,2	€ 10,00 gr.07,2	€ 9,50 gr.08	
HTRoll	66 9420.N0	66 9420.I0	66 9420.E0	66 9823.R0	
ROLLERS FOR ORIGINAL VARIATOR	€ 10,00 gr.07,5	€ 10,00 gr.06,5	€ 10,00 gr.05,5	€ 9,50 gr.08,5	
	VENTILVAR	-	-	-	-
	FIXED HALF-PULLEY	-	-	-	-
	VARIABLE-SPEED DRIVE ADJUSTER SPRING	PG.438	PG.438	PG.438	PG.438
	FOR VARIATOR	-	-	-	-
	TORSION CONTROLLER	2512828	2512828	2512828	2512828
	ANTIFRICTION FIFTH WHEEL	€ 4,45	€ 4,45	€ 4,45	€ 4,45
	TORQUE DRIVER	61 9100	61 9100	61 9100	61 8233
	MOBILE DRIVEN SPLIT PULLEY	€ 85,57	€ 85,57	€ 85,57	€ 85,57
	FLY CLUTCH	52 8797	52 8797	52 8797	52 8797
	NOT ADJUSTABLE CLUTCH	€ 47,30	€ 47,30	€ 47,30	€ 47,30
	DELTA CLUTCH	52 7880	52 7880	52 7880	52 7880
	ADJUSTABLE CLUTCH	€ 77,89	€ 77,89	€ 77,89	€ 77,89
	CLUTCH BELL	7711115	7711115	7711115	7711115
	CLUTCH BELL (SMOOTH RING)	€ 22,60 Ø 107	€ 22,60 Ø 107	€ 22,60 Ø 107	€ 22,60 Ø 107
	WING CLUTCH BELL	7711207	7711207	7711207	7711207
	CLUTCH BELL (FINNED RING)	€ 33,45 Ø 107	€ 33,45 Ø 107	€ 33,45 Ø 107	€ 33,45 Ø 107
	FLY SYSTEM	5214111	5214111	5214111	5214111
	CLUTCH BELL + NOT ADJUSTABLE CLUTCH	€ 63,00 Ø 107	€ 63,00 Ø 107	€ 63,00 Ø 107	€ 63,00 Ø 107
	DELTA SYSTEM	5214110	5214110	5214110	5214110
	CLUTCH BELL + ADJUSTABLE CLUTCH	€ 93,84 Ø 107	€ 93,84 Ø 107	€ 93,84 Ø 107	€ 93,84 Ø 107
	SPORT SPRINGS	29 8746	29 8746	29 8746	29 8746
	FOR FLY / DELTA CLUTCH	€ 14,50	€ 14,50	€ 14,50	€ 14,50
	MHR SPRINGS	29 8747	29 8747	29 8747	29 8747
	FOR FLY / DELTA CLUTCH	€ 19,40	€ 19,40	€ 19,40	€ 19,40
	SPRINGS Ø INTERNAL CLUTCH BELL 105-107	29 7454	29 7454	29 7454	29 7454
FOR ORIGINAL CLUTCH	€ 16,20	€ 16,20	€ 16,20	€ 16,20	
	MUELLES Ø INTERNAL CLUTCH BELL 112	-	-	-	-
	FOR ORIGINAL CLUTCH	-	-	-	-

35 - IT CAN BE ASSEMBLED WITH NO MODIFICATION to the original system, EVEN ON vehicles PRODUCED 2001->

36 - IT CAN BE ASSEMBLED WITH NO MODIFICATION to the original system

PIAGGIO

QUARTZ	SFERA RESTYLING	TYPHOON 2007->2010	TYPHOON euro 2 2011->	ZIP <-1999	ZIP 2000->	ZIP Fast Rider	ZIP SP <-2000
			(C421M)				
50 2T LC	50 2T	50 2T	50 2T	50 2T	50 2T	50 2T	50 2T LC
31 8523 €164,21 Ø 40 (12)	31 8520 €124,91 Ø 40 (12)	31 8520 €124,91 Ø 40 (12)	31 8520 €124,91 Ø 40 (12)	31 8520 €124,91 Ø 40 (12)	31 8520 €124,91 Ø 40 (12)	31 8520 €124,91 Ø 40 (12)	31 8523 €164,21 Ø 40 (12)
31 7353 €176,03 Ø 47 (12)	31 6926 €120,25 Ø 47 (12)	31 6926 €120,25 Ø 47 (12)	31 6926 €120,25 Ø 47 (12)	31 6926 €120,25 Ø 47 (12)	31 6926 €120,25 Ø 47 (12)	31 6926 €120,25 Ø 47 (12)	31 7353 €176,03 Ø 47 (12)
-	31 6915 €100,86 Ø 47 (12)	31 6915 €100,86 Ø 47 (12)	31 6915 €100,86 Ø 47 (12)	31 6915 €100,86 Ø 47 (12)	31 6915 €100,86 Ø 47 (12)	31 6915 €100,86 Ø 47 (12)	-
-	38 7118 €37,45 Ø 47	38 7118 €37,45 Ø 47	38 7118 €37,45 Ø 47	38 7118 €37,45 Ø 47	38 7118 €37,45 Ø 47	38 7118 €37,45 Ø 47	-
31 8466 €239,46 Ø 47 (12)	31 8463 €207,00 Ø 47 (12)	31 8463 €207,00 Ø 47 (12)	31 8463 €207,00 Ø 47 (12)	31 8463 €207,00 Ø 47 (12)	31 8463 €207,00 Ø 47 (12)	31 8463 €207,00 Ø 47 (12)	31 8466 €239,46 Ø 47 (12)
-	-	-	-	-	-	-	-
53 7600 €175,50	53 7600 €175,50	53 7600 €175,50	53 7600 €175,50	53 7600 €175,50	53 7600 €175,50	53 7600 €175,50	53 7600 €175,50
6614105E €43,00	6614105E €43,00	6614105E €43,00	6614105E €43,00	6614105E €43,00	6614105E €43,00	6614105E €43,00	6614105E €43,00
5513195 *35* €92,82	5513195 *35* €92,82	5513195 *36* €92,82	5513195 *36* €92,82	5513195 *35* €92,82	5513195 *35* €92,82	5513195 *35* €92,82	5513195 *35* €92,82
5513196 *35* €140,51	5513196 *35* €140,51	5513196 *36* €140,51	5513196 *36* €140,51	5513196 *35* €140,51	5513196 *35* €140,51	5513196 *35* €140,51	5513196 *35* €140,51
51 7382 €58,71	51 7382 €58,71	51 9019 €61,80	51 9019 €61,80	51 7081 €60,00	51 9019 €61,80 51 9448 1997 €60,00	51 7382 €58,71	51 7382 €58,71
61 9829 €20,63	61 9829 €20,63	61 9831 €19,49	61 9830 €17,34	-	6111246 €18,50	61 9829 €20,63	61 9829 €20,63
61 7665 €25,68	61 7665 €25,68	6114118 €38,25	61 9535 €28,72	61 7229 €20,24	6114114 €38,76	61 7665 €25,68	61 7665 €25,68
66 9823.NO €9,50 gr.08	66 9823.NO €9,50 gr.08	66 9420.M0 €10,00 gr.07,2	66 9420.M0 €10,00 gr.07,2	66 9823.L0 €9,50 gr.06	66 9420.M0 €10,00 gr.07,2	66 9823.NO €9,50 gr.08	66 9823.NO €9,50 gr.08
66 9823.R0 €9,50 gr.08,5	66 9823.R0 €9,50 gr.08,5	66 9420.N0 €10,00 gr.07,5	66 9420.N0 €10,00 gr.07,5	66 9823.R0 €9,50 gr.08,5	66 9420.N0 €10,00 gr.07,5	66 9823.R0 €9,50 gr.08,5	66 9823.M0 €9,50 gr.07
-	-	-	-	-	-	-	-
PG.438	PG.438	PG.438	PG.438	PG.438	PG.438	PG.438	PG.438
2512828 €4,45	2512828 €4,45	2512828 €4,45	2512828 €4,45	-	2512828 €4,45	2512828 €4,45	2512828 €4,45
61 8233 €85,57	61 8233 €85,57	61 9100 €85,57	61 9100 €85,57	-	61 9100 €85,57	61 8233 €85,57	61 8233 €85,57
52 8797 €47,30	52 8797 €47,30	52 8797 €47,30	52 8797 €47,30	-	52 8797 €47,30	52 8797 €47,30	52 8797 €47,30
52 7880 €77,89	52 7880 €77,89	52 7880 €77,89	52 7880 €77,89	-	52 7880 €77,89	52 7880 €77,89	52 7880 €77,89
7711115 €22,60 Ø 107	7711115 €22,60 Ø 107	7711115 €22,60 Ø 107	7711115 €22,60 Ø 107	-	7711115 €22,60 Ø 107	7711115 €22,60 Ø 107	7711115 €22,60 Ø 107
7711207 €33,45 Ø 107	7711207 €33,45 Ø 107	7711207 €33,45 Ø 107	7711207 €33,45 Ø 107	-	7711207 €33,45 Ø 107	7711207 €33,45 Ø 107	7711207 €33,45 Ø 107
5214111 €63,00 Ø 107	5214111 €63,00 Ø 107	5214111 €63,00 Ø 107	5214111 €63,00 Ø 107	-	5214111 €63,00 Ø 107	5214111 €63,00 Ø 107	5214111 €63,00 Ø 107
5214110 €93,84 Ø 107	5214110 €93,84 Ø 107	5214110 €93,84 Ø 107	5214110 €93,84 Ø 107	-	5214110 €93,84 Ø 107	5214110 €93,84 Ø 107	5214110 €93,84 Ø 107
29 8746 €14,50	29 8746 €14,50	29 8746 €14,50	29 8746 €14,50	-	29 8746 €14,50	29 8746 €14,50	29 8746 €14,50
29 8747 €19,40	29 8747 €19,40	29 8747 €19,40	29 8747 €19,40	-	29 8747 €19,40	29 8747 €19,40	29 8747 €19,40
29 7454 €16,20	29 7457 €16,20	29 7454 €16,20	29 7454 €16,20	29 7454 €16,20	29 7454 €16,20	29 7454 €16,20	29 7454 €16,20
-	-	-	-	-	-	-	-



MALOSSI

Scooter 2T

with ENGINE 

PIAGGIO

NRG Power DD

NRG Power DT

NRG Power
Purejet

NTT

(C453M)

50 2T

LC

50 2T















50 2T

LC

50 2T

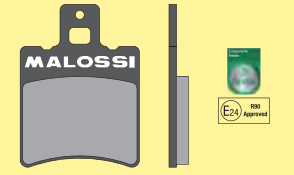
LC

(■) CHECK "TYPE" SPECIFICATION (HOMOLOGATION MARK)

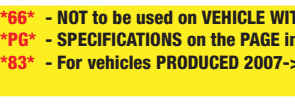
	CARBURETTOR		72 7084 € 75,17 Ø 17,5	72 7084 € 75,17 Ø 17,5	-	72 7084 € 75,17 Ø 17,5
	CARBURETTOR KIT	Ø 19	1611040 € 118,04	1611040 € 118,04	-	1611040 € 118,04
	CARBURETTOR KIT	Ø 21	1610997 € 114,23	1610997 € 114,23	-	1610997 € 114,23
	CARBURETTOR KIT	Ø 22	1611029 € 96,77	1611029 € 96,77	-	1611029 € 96,77
	REED VALVE CARBON FIBRE		27 7708.CO € 48,95 VL11	27 7708.CO € 48,95 VL11	27 7708.CO € 48,95 VL11	27 7708.CO € 48,95 VL11
	PETALS SET FOR ORIGINAL REED VALVE		27 7054.CO € 18,71	27 7054.CO € 18,71	27 7054.CO € 18,71	27 7054.CO € 18,71
	ART OF PERFORMANCE / FLIP HOMOLOGATED 	PG. 426	3215167 € 175,70 3216692 € 122,00	-	3215167 € 175,70 3216692 € 122,00	-
	WILD LION HOMOLOGATED 	PG. 424	3216580 € 87,00	-	3216580 € 87,00	3216580 € 87,00
	RED SPONGE FOR ORIGINAL AIR BOX		1411778 € 3,54	1411778 € 3,54	1412205 € 5,77	1411422 € 4,29 1995->96
	DOUBLE RED SPONGE FOR ORIGINAL AIR BOX		1414497 € 6,16	1414497 € 6,16	-	1414506 € 6,65 1995->96
	GEARS HTQ PRIMARY		67 9080 z 14/39 € 60,41 6713339 z 15/38 € 61,71	67 9080 z 14/39 € 60,41 6713339 z 15/38 € 61,71	67 9080 z 14/39 € 60,41 6713339 z 15/38 € 61,71	67 8218 z14/39 (18) € 56,53 67 8220 (17) € 56,53
	GEARS HTQ SECONDARY	PG. 478	67 9966 € 65,00 z 13/48	67 9966 € 65,00 z 13/48	67 9966 € 65,00 z 13/48	67 8938 *PG* € 60,41 z13/48 (17)
	ROLLER CRANKCASE		2514521 *66* € 95,00	2514521 *66* € 95,00	2514521 *66* € 95,00	-
	SCREEN		-	-	-	-
	BRAKE PADS	FRONT	6215042 € 5,72 1998->	-	6215059 € 8,84	6215042 € 5,72 1995->
	BRAKE PADS MHR	FRONT	6215080 *83* € 6,00 1998->	-	6212164 € 8,50	6215080 € 6,00 1995->
	BRAKE PADS MHR SYNT	FRONT	6215007 € 11,96 1998->	-	-	6215007 € 11,96 1995->
	BRAKE PADS	REAR	6215049 € 6,24 1998->	-	6215049 € 6,24	-
	BRAKE PADS MHR	REAR	6215074 € 6,30 1998->	-	6215074 € 6,30	-
	BRAKE PADS MHR SYNT	REAR	6215006 € 11,96 1998->	-	6215006 € 11,96	-
	BRAKE POWER	REAR	-	6215328 € 18,39	-	6215806 1995-> € 15,00
	BRAKE SHOES	FRONT	-	-	-	62 7843 <-1994 € 15,44
	WHOO P DISC	FRONT	6212929 € 105,00 1998->	-	-	6212603 € 72,56
	WHOO P DISC	REAR	-	-	-	-
	RS1 - RS3	REAR SHOCK ABSORBER	4615432 € 94,86 46 7908 € 140,92	4615432 € 94,86 46 7908 € 140,92	4615432 € 94,86 46 7908 € 140,92	4615432 € 94,86 46 7908 € 140,92
	RS24 - RS24/10	FRONT SHOCK ABSORBER	-	-	-	-
	RS24 - RS24/10 - RS24/10-R	REAR SHOCK ABSORBER	46 8308 € 248,50	46 8308 € 248,50	46 8308 € 248,50	46 8308 € 248,50
	RS24	FRONT + REAR	-	-	-	-
	HORQUILLA F32S	FORK STEMS Ø 32	-	46 9550 € 591,80	-	46 9550 € 591,80
	HORQUILLA F37R MHR	FORK STEMS Ø 37	-	-	-	-

66 - NOT to be used on VEHICLE WITH ORIGINAL PRIMARY GEARS

PG - SPECIFICATIONS on the PAGE indicated in the TITLE of the LINE

83 - For vehicles PRODUCED 2007-> with Heng Tong CALIPER: 6212164 € 8,50



MALOSSI

Scooter 2T

with ENGINE 

PIAGGIO

SUZUKI

ZIP SP
2001->

ADDRESS AH

ADDRESS V

AP

(▲) ATTENTION: ONLY FOR vehicles WITHOUT IMMOBILIZER KEY

50 2T

LC

50 2T



100 2T



50 2T



	CYLINDER+HEAD CAST-IRON Ø 40	31 8523	31 9092	-	31 9092
	(pin) ALUMINIUM Ø 40-41	€164,21 Ø 40 (12)	€214,45 Ø 41 (10)	-	€214,45 Ø 41 (10)
	CYLINDER+HEAD	31 7353	31 8723	-	31 8723
	(pin) CAST-IRON Ø 47	€176,03 Ø 47 (12)	€123,02 Ø 47 (10)	-	€123,02 Ø 47 (10)
	CYLINDER CAST-IRON Ø 47-57,5	-	31 7137	3112029	31 7137
	for ORIGINAL HEAD ALUM. Ø 47>57,5	-	€106,52 Ø 47 (10)	€225,68 Ø 57,5 (12)	€106,52 Ø 47 (10)
	HEAD HTSR	-	38 9041	-	38 9041
	for Malossi CYLINDER	-	€37,47 Ø 47	-	€37,47 Ø 47
	CYLINDER+HEAD MHR Replica ALUMINIUM	31 8466	-	-	-
	(pin) Ø 47	€239,46 Ø 47 (12)	-	-	-
	CRANKSHAFTS RHQ	-	53 8631	-	53 8631
	PIN Ø 10	-	€294,80	-	€294,80
	CRANKSHAFTS RHQ	53 7600	-	-	-
	PIN Ø 12	€175,50	-	-	-
	RADIAL ROLLER BEARING	6614105E	-	-	-
	FOR CRANKSHAFT	PG. 473 €43,00	-	-	-
	ELECTRONIC CONTROLLER	5513195 *35*	-	-	-
		€92,82	-	-	-
	ELECTRONIC CONTROLLER	5513196 *35*	-	-	-
	RPM CONTROL	€140,51	-	-	-
	MULTIVAR	51 9019 €61,80	51 7128	5112026	51 7128
	VARIATOR	51 9448 1997 €60,00	€58,71	€61,80	€58,71
	X SPECIAL BELT	6111246	-	-	-
	BELT	€18,50	-	-	-
	X K BELT	6114114	61 7231	-	61 7231
	BELT	€38,76	€23,22	-	€23,22
	HTRoll	66 9420.M0	66 9823.M0	66 9823.S0	66 9823.M0
	ROLLERS FOR MULTIVAR	€10,00 gr.07,2	€9,50 gr.07	€9,50 gr.14	€9,50 gr.07
	HTRoll	66 9420.NO	66 9999.F0	-	66 9999.F0
	ROLLERS FOR ORIGINAL VARIATOR	€10,00 gr.07,5	€8,50 gr.06,5	-	€8,50 gr.06,5
	VENTILVAR	-	-	-	-
	FIXED HALF-PULLEY	-	-	-	-
	VARIABLE-SPEED DRIVE ADJUSTER SPRING	PG. 438 PG.438	PG.438	-	PG.438
	FOR VARIATOR	-	-	-	-
	TORSION CONTROLLER	2512828	-	-	-
	ANTIFRICTION FIFTH WHEEL	€4,45	-	-	-
	TORQUE DRIVER	61 9100	-	-	-
	MOBILE DRIVEN SPLIT PULLEY	€85,57	-	-	-
	FLY CLUTCH	52 8797	52 8798	-	52 8798
	NOT ADJUSTABLE CLUTCH	€47,30	€47,30	-	€47,30
	DELTA CLUTCH	52 7880	52 7879	-	52 7879
	ADJUSTABLE CLUTCH	€77,89	€77,89	-	€77,89
	CLUTCH BELL	7711115	-	-	-
	CLUTCH BELL (SMOOTH RING)	€22,60 Ø 107	-	-	-
	WING CLUTCH BELL	7711207	-	-	-
	CLUTCH BELL (FINNED RING)	€33,45 Ø 107	-	-	-
	FLY SYSTEM	5214111	-	-	-
	CLUTCH BELL + NOT ADJUSTABLE CLUTCH	€63,00 Ø 107	-	-	-
	DELTA SYSTEM	5214110	-	-	-
	CLUTCH BELL + ADJUSTABLE CLUTCH	€93,84 Ø 107	-	-	-
	SPORT SPRINGS	29 8746	29 8746	-	29 8746
	FOR FLY / DELTA CLUTCH	€14,50	€14,50	-	€14,50
	MHR SPRINGS	29 8747	29 8747	-	29 8747
	FOR FLY / DELTA CLUTCH	€19,40	€19,40	-	€19,40
	SPRINGS Ø INTERNAL CLUTCH BELL 105-107	29 7454	29 7456	-	29 7456
	FOR ORIGINAL CLUTCH	€16,20	€16,20	-	€16,20
	MUELLES Ø INTERNAL CLUTCH BELL 112	-	-	-	-
	FOR ORIGINAL CLUTCH	-	-	-	-

35 - IT CAN BE ASSEMBLED WITH NO MODIFICATION to the original system, EVEN ON vehicles PRODUCED 2001->

SUZUKI							SYM
ESTILETE UF	KATANA	KATANA	SEPIA	SEPIA ZZ	STREET MAGIC	ZILLION	CINDERELLA
50 2T	50 2T	50 2T	50 2T	50 2T	50 2T	50 2T	100 2T
31 9092 € 214,45 Ø 41 (10)	31 9092 € 214,45 Ø 41 (10)	-	31 9092 € 214,45 Ø 41 (10)	31 9092 € 214,45 Ø 41 (10)	-	-	-
31 8723 € 123,02 Ø 47 (10)	31 8723 € 123,02 Ø 47 (10)	31 9541 € 166,72 Ø 47 (12)	31 8723 € 123,02 Ø 47 (10)	31 8723 € 123,02 Ø 47 (10)	31 8723 € 123,02 Ø 47 (10)	31 9541 € 166,72 Ø 47 (12)	-
31 7137 € 106,52 Ø 47 (10)	31 7137 € 106,52 Ø 47 (10)	-	31 7137 € 106,52 Ø 47 (10)	31 7137 € 106,52 Ø 47 (10)	31 7137 € 106,52 Ø 47 (10)	-	-
38 9041 € 37,47 Ø 47	38 9041 € 37,47 Ø 47	-	38 9041 € 37,47 Ø 47	38 9041 € 37,47 Ø 47	38 9041 € 37,47 Ø 47	-	-
-	-	-	-	-	-	-	-
-	53 9592 € 264,23 <-1998	-	53 8631 € 294,80	53 8631 € 294,80	-	-	-
-	-	-	-	-	-	-	-
-	-	-	-	-	-	-	-
-	-	-	-	-	-	-	-
5111298 € 65,00	5111298 1999-> € 65,00 51 7128 <-1998 € 58,71	5111298 1999-> € 65,00 51 7128 <-1998 € 58,71	51 7128 € 58,71	51 7128 € 58,71	51 9994 € 63,86	5111298 € 65,00	-
6111295 € 17,71	6111295 € 17,71 1999->	6111295 € 17,71 1999->	-	-	-	6111295 € 17,71	-
6111294 € 28,38	6111294 1999-> € 28,38 61 9591 <-1998 € 25,17	6111294 1999-> € 28,38 61 9591 <-1998 € 25,17	61 7231 € 23,22	61 7231 € 23,22	-	6111294 € 28,38	-
66 9823.NO € 9,50 gr.08	66 9823.NO gr.08 1999-> € 9,50 66 9823.MO gr.07 <-1998 € 9,50	66 9823.MO € 9,50 gr.07	66 9823.MO € 9,50 gr.07	66 9823.MO € 9,50 gr.07	66 9823.LO gr.06 € 9,50 66 9823.MO gr.07 € 9,50	66 9823.NO € 9,50 gr.08	-
66 9999.FO € 8,50 gr.06,5	66 9999.FO € 8,50 gr.06,5	66 9999.FO € 8,50 gr.06,5	66 9999.FO € 8,50 gr.06,5	66 9999.FO € 8,50 gr.06,5	66 9999.FO € 8,50 gr.06,5	66 9999.FO € 8,50 gr.06,5	66 9823.Q0 € 9,50 gr.07,5
-	-	-	-	-	-	-	-
PG.438	PG.438	PG.438	PG.438	PG.438	PG.438	PG.438	-
-	-	-	-	-	-	-	-
-	-	-	-	-	-	-	-
52 8798 € 47,30	52 8798 € 47,30	52 8798 € 47,30	52 8798 € 47,30	52 8798 € 47,30	52 8798 € 47,30	52 8798 € 47,30	-
52 7879 € 77,89	52 7879 € 77,89	52 7879 € 77,89	52 7879 € 77,89	52 7879 € 77,89	52 7879 € 77,89	52 7879 € 77,89	-
-	-	-	-	-	-	-	-
-	-	-	-	-	-	-	-
-	-	-	-	-	-	-	-
29 8746 € 14,50	29 8746 € 14,50	29 8746 € 14,50	29 8746 € 14,50	29 8746 € 14,50	29 8746 € 14,50	29 8746 € 14,50	-
29 8747 € 19,40	29 8747 € 19,40	29 8747 € 19,40	29 8747 € 19,40	29 8747 € 19,40	29 8747 € 19,40	29 8747 € 19,40	-
29 7456 € 16,20	29 7456 € 16,20	29 7456 € 16,20	29 7456 € 16,20	29 7456 € 16,20	29 7456 € 16,20	29 7456 € 16,20	-
-	-	-	-	-	-	-	-



MALOSSI

Scooter 2T

with ENGINE 

PIAGGIO

SUZUKI

ZIP SP
2001->

ADDRESS AH

ADDRESS V

AP













50 2T

LC

50 2T

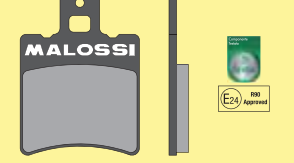
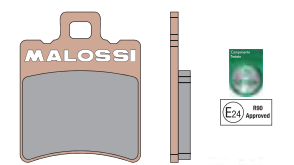
100 2T

50 2T

CHECK "TYPE" SPECIFICATION (HOMOLOGATION MARK)		50 2T	LC	50 2T	100 2T	50 2T
	CARBURETTOR	72 7084 € 75,17 Ø 17,5	-	-	-	-
	CARBURETTOR KIT Ø 19	1611040 € 118,04	-	-	-	-
	CARBURETTOR KIT Ø 21	1610997 € 114,23	1611014 € 170,33	-	-	1611014 € 170,33
	CARBURETTOR KIT Ø 22	1611029 € 96,77	-	-	-	-
	REED VALVE CARBON FIBRE	27 7708.CO € 48,95 VL11	-	-	-	-
	PETALS SET FOR ORIGINAL REED VALVE	27 7054.CO € 18,71	27 2728.CO € 16,27	-	-	27 2728.CO € 16,27
	ART OF PERFORMANCE / FLIP HOMOLOGATED 	PG. 426 -	-	-	-	-
	WILD LION HOMOLOGATED 	PG. 424 3216590 € 87,00	-	-	-	-
	RED SPONGE FOR ORIGINAL AIR BOX	1411778 € 3,54	-	-	1412132 € 3,95	-
	DOUBLE RED SPONGE FOR ORIGINAL AIR BOX	1414497 € 6,16	67 7149 € 53,80 z 14/34	-	-	-
	GEARS HTQ PRIMARY	6711449 z 16/37 € 60,41 6713339 z 15/38 € 61,71	-	-	-	67 7149 € 53,80 z 14/34
	GEARS HTQ SECONDARY	PG. 478 67 9968 *PG* € 61,65 z 14/47	-	-	-	-
	ROLLER CRANKCASE	2514521 *66* € 95,00	-	-	-	-
	SCREEN	-	-	-	-	-
	BRAKE PADS FRONT	6215049 € 6,24	-	-	6212165 € 16,50 2000->	6215043 € 5,80 1995->
	BRAKE PADS MHR FRONT	6215074 € 6,30	-	-	6212166 € 16,50 2000->	62 9083 € 6,20 1995->
	BRAKE PADS MHR SYNT FRONT	6215006 € 11,96	-	-	-	6215008 € 11,96 1995->
	BRAKE PADS REAR	-	-	-	-	-
	BRAKE PADS MHR REAR	-	-	-	-	-
	BRAKE PADS MHR SYNT REAR	-	-	-	-	-
	BRAKE POWER REAR	6215328	-	-	-	-
	BRAKE SHOES FRONT	€ 18,39	-	-	-	-
	WHOOP DISC FRONT	6212604 € 76,38	-	-	-	-
	WHOOP DISC REAR	-	-	-	-	-
	RS1 - RS3 REAR SHOCK ABSORBER	4615432 € 94,86 46 7908 € 140,92	46 7905 € 140,92	-	-	46 7905 € 140,92
	RS24 - RS24/10 FRONT SHOCK ABSORBER	46 7900 € 222,63	-	-	-	-
	RS24 - RS24/10 - RS24/10-R REAR SHOCK ABSORBER	46 8308 € 248,50 4614237 € 428,82	46 7588 € 255,97	-	-	46 7588 € 255,97
	RS24 FRONT + REAR	46 9031 € 456,47	-	-	-	-
	HORQUILLA F32S FORK STEMS Ø 32	-	-	-	-	-
	HORQUILLA F37R MHR FORK STEMS Ø 37	-	-	-	-	-

29 - ONLY FOR vehicles PRODUCED 1997-> - with BREMBO CALIPER: homolog. 6215042 € 5,72

30 - ONLY FOR vehicles PRODUCED 1997-> - with BREMBO CALIPER: 6215080 € 6,00

31 - ONLY FOR vehicles PRODUCED 1997-> - with BREMBO CALIPER: homolog. 6215007 € 11,96

66 - NOT to be used on VEHICLE WITH ORIGINAL PRIMARY GEARS

SUZUKI							SYM
ESTILETE UF	KATANA	KATANA	SEPIA	SEPIA ZZ	STREET MAGIC	ZILLION	CINDERELLA
50 2T	50 2T	50 2T	50 2T	50 2T	50 2T	50 2T	100 2T
-	-	-	-	-	-	-	-
1611039 € 124,50	1611039 € 124,50	1611039 € 124,50	-	-	1611051 € 151,65	1611039 € 124,50	-
-	-	-	1611014 € 170,33	1611014 € 170,33	-	-	-
-	-	-	-	-	-	-	-
27 7731.C0 € 48,95 VL12	27 7731.C0 € 48,95 VL12	27 7731.C0 € 48,95 VL12	-	-	27 7731.C0 € 48,95 VL12	27 7731.C0 € 48,95 VL12	-
27 7054.C0 € 18,71	27 7054.C0 € 18,71	27 7054.C0 € 18,71	27 2728.C0 € 16,27	27 2728.C0 € 16,27	27 7054.C0 € 18,71	27 7054.C0 € 18,71	-
-	-	-	-	-	-	-	-
-	-	-	-	-	-	-	-
-	-	-	-	-	-	-	-
6711297 € 121,34 z 15/40	6711297 z15/40 1999-> € 121,34 67 9433 <-1998 € 53,80	6711297 z15/40 1999-> € 121,34 67 9433 <-1998 € 53,80	67 7149 € 53,80 z 14/34	67 7835 € 45,77 z 14/34	-	6711297 € 121,34 z 15/40	-
-	-	-	-	-	-	-	-
-	-	-	-	-	-	-	-
6215051 € 5,72 2000->	6215051 *29* € 5,72 1998->	6215051 € 5,72 1998->	-	-	6212165 € 16,50 1998->	6215051 € 5,72 1998->	-
6215076 € 6,24 2000->	6215076 *30* € 6,24 1998->	6215076 € 6,24 1998->	-	-	6212166 € 16,50 1998->	6215076 € 6,24 1998->	-
6215005 € 11,96 2000->	6215005 *31* € 11,96 1998->	6215005 € 11,96 1998->	-	-	-	6215005 € 11,96 1998->	-
-	-	-	-	-	-	-	-
-	-	-	-	-	-	-	-
-	-	-	-	-	-	-	-
-	-	-	-	-	-	-	-
-	-	-	-	-	-	-	-
-	-	-	46 7905 € 140,92	46 7905 € 140,92	-	-	-
-	-	-	-	-	-	-	-
-	-	-	46 7588 € 255,97	46 7588 € 255,97	4614223 € 430,00	-	-
-	-	-	-	-	-	-	-
-	-	-	-	-	-	-	-
-	-	-	-	-	-	-	-

PG - SPECIFICATIONS on the PAGE indicated in the TITLE of the LINE



MALOSSI

Scooter 2T

with ENGINE 

SYM

VESPA

DD

JET Basix
euro 2JET SportX-S -
SportX-R
euro 2ET2
<-1999

(T5C/1)

50 2T



50 2T



50 2T



50 2T

**(▲) ATTENTION: ONLY FOR vehicles WITHOUT IMMOBILIZER KEY**

	CYLINDER+HEAD CAST-IRON Ø 40	-	-	-	31 8520
	(pin) ALUMINIUM Ø 40-41				€124,91 Ø 40 (12)
	CYLINDER+HEAD	31 7200	3113570	3113570	31 6926
	(pin) CAST-IRON Ø 47	€123,02 Ø 47 (12)	€138,27 Ø 47 (12)	€138,27 Ø 47 (12)	€120,25 Ø 47 (12)
	CYLINDER CAST-IRON Ø 47-57,5	31 6998	-	-	31 6915
for ORIGINAL HEAD ALUM. Ø 47>57,5	€104,07 Ø 47 (12)			€100,86 Ø 47 (12)	
	HEAD HTSR	38 7007	3813573	3813573	38 7118
	for Malossi CYLINDER	€37,45 Ø 47	€37,45 Ø 47	€37,45 Ø 47	€37,45 Ø 47
	CYLINDER+HEAD MHR Replica ALUMINIUM	31 8473	-	-	31 8463
	(pin) Ø 47	€217,30 Ø 47 (12)			€207,00 Ø 47 (12)
	CRANKSHAFTS RHQ	-	-	-	-
	PIN Ø 10				
	CRANKSHAFTS RHQ	53 7604	-	-	53 7600
	PIN Ø 12	€185,00			€175,50
	RADIAL ROLLER BEARING FOR CRANKSHAFT	-	-	-	6614105E
	PG. 473				€43,00
	ELECTRONIC CONTROLLER	-	-	-	5513195 *35*
	(▲)				€92,82
	ELECTRONIC CONTROLLER RPM CONTROL	-	-	-	5513196 *35*
					€140,51
	MULTIVAR	51 7484	51 7484	51 7484	51 7382
	VARIATOR	€58,71	€58,71	€58,71	€58,71
	X SPECIAL BELT	-	-	-	61 9829
	BELT				€20,63
	X K BELT	61 7211	-	-	61 7665
	BELT	€25,68			€25,68
	HTRoll	66 9823.M0	66 9823.M0	66 9823.M0	66 9823.N0
	ROLLERS FOR MULTIVAR	€9,50 gr.07	€9,50 gr.07	€9,50 gr.07	€9,50 gr.08
	HTRoll	66 9823.R0	66 9823.R0	66 9823.R0	66 9823.R0
	ROLLERS FOR ORIGINAL VARIATOR	€9,50 gr.08,5	€9,50 gr.08,5	€9,50 gr.08,5	€9,50 gr.08,5 <-1997
	VENTILVAR	-	-	-	-
	FIXED HALF-PULLEY				
	VARIABLE-SPEED DRIVE ADJUSTER SPRING	PG. 438	PG.438	PG.438	PG.438
	FOR VARIATOR				
	TORSION CONTROLLER	2512828	2512828	2512828	2512828
	ANTIFRICTION FIFTH WHEEL	€4,45	€4,45	€4,45	€4,45
	TORQUE DRIVER	61 8317	61 8317	61 8317	61 8233
	MOBILE DRIVEN SPLIT PULLEY	€95,61	€95,61	€95,61	€85,57
	FLY CLUTCH	52 8797	52 8797	52 8797	52 8797
	NOT ADJUSTABLE CLUTCH	€47,30	€47,30	€47,30	€47,30
	DELTA CLUTCH	52 7880	52 7880	52 7880	52 7880
	ADJUSTABLE CLUTCH	€77,89	€77,89	€77,89	€77,89
	CLUTCH BELL	7711115	7711115	7711115	7711115
	CLUTCH BELL (SMOOTH RING)	€22,60 Ø 107	€22,60 Ø 107	€22,60 Ø 107	€22,60 Ø 107
	WING CLUTCH BELL	-	7711207	7711207	7711207
	CLUTCH BELL (FINNED RING)		€33,45 Ø 107	€33,45 Ø 107	€33,45 Ø 107
	FLY SYSTEM	5214111	5214111	5214111	5214111
	CLUTCH BELL + NOT ADJUSTABLE CLUTCH	€63,00 Ø 107	€63,00 Ø 107	€63,00 Ø 107	€63,00 Ø 107
	DELTA SYSTEM	-	5214110	5214110	5214110
	CLUTCH BELL + ADJUSTABLE CLUTCH		€93,84 Ø 107	€93,84 Ø 107	€93,84 Ø 107
	SPORT SPRINGS	29 8746	29 8746	29 8746	29 8746
	FOR FLY / DELTA CLUTCH	€14,50	€14,50	€14,50	€14,50
	MHR SPRINGS	29 8747	29 8747	29 8747	29 8747
	FOR FLY / DELTA CLUTCH	€19,40	€19,40	€19,40	€19,40
	SPRINGS Ø INTERNAL CLUTCH BELL 105-107	29 7454	29 9605	29 9605	29 7454
	FOR ORIGINAL CLUTCH	€16,20	€16,20	€16,20	€16,20
	MUELLES Ø INTERNAL CLUTCH BELL 112	-	-	-	-
	FOR ORIGINAL CLUTCH				

35 - IT CAN BE ASSEMBLED WITH NO MODIFICATION to the original system, EVEN ON vehicles PRODUCED 2001->

36 - IT CAN BE ASSEMBLED WITH NO MODIFICATION to the original system

PG - SPECIFICATIONS on the PAGE indicated in the TITLE of the LINE





VESPA					YAMAHA		
ET2 2000->	LX	Primavera euro 2	S euro 2	Sprint euro 2	AEROX euro 0-1	AEROX euro 2	AEROX
		(C533M)	(C381M)				
50 2T	50 2T	50 2T	50 2T	50 2T	50 2T	50 2T	100 2T
31 8520 €124,91 Ø 40 (12)	31 8520 €124,91 Ø 40 (12)	31 8520 €124,91 Ø 40 (12)	31 8520 €124,91 Ø 40 (12)	31 8520 €124,91 Ø 40 (12)	31 8556 1 €161,98 Ø 40 (10)	31 8556 1 €161,98 Ø 40 (10)	-
31 6926 €120,25 Ø 47 (12)	31 6926 €120,25 Ø 47 (12)	31 6926 €120,25 Ø 47 (12)	31 6926 €120,25 Ø 47 (12)	31 6926 €120,25 Ø 47 (12)	31 8284 1 €152,41 Ø 47 (10)	31 8284 1 €152,41 Ø 47 (10)	-
31 6915 €100,86 Ø 47 (12)	31 6915 €100,86 Ø 47 (12)	31 6915 €100,86 Ø 47 (12)	31 6915 €100,86 Ø 47 (12)	31 6915 €100,86 Ø 47 (12)	-	-	3111374 €167,85 Ø 57,5 (14)
38 7118 €37,45 Ø 47	38 7118 €37,45 Ø 47	38 7118 €37,45 Ø 47	38 7118 €37,45 Ø 47	38 7118 €37,45 Ø 47	-	-	-
31 8463 €207,00 Ø 47 (12)	31 8463 €207,00 Ø 47 (12)	31 8463 €207,00 Ø 47 (12)	31 8463 €207,00 Ø 47 (12)	31 8463 €207,00 Ø 47 (12)	31 8430 €228,06 Ø 47 (10)	31 8430 1 €228,06 Ø 47 (10)	-
-	-	-	-	-	53 7891 €175,50	53 7891 €175,50	-
53 7600 €175,50	53 7600 €175,50	53 7600 €175,50	53 7600 €175,50	53 7600 €175,50	53 8009 €175,50	53 8009 €175,50	-
6614105E €43,00	6614105E €43,00	6614105E €43,00	6614105E €43,00	6614105E €43,00	PG.473	PG.473	-
5513195 *35* €92,82	5513195 *35* €92,82	5513195 *36* €92,82	5513195 *36* €92,82	5513195 *36* €92,82	55 8133 €50,14	-	-
5513196 *35* €140,51	5513196 *35* €140,51	5513196 *36* €140,51	5513196 *36* €140,51	5513196 *36* €140,51	55 8676 €97,59	5512790 €157,87	-
51 9019 €61,80 51 9448 1997 €60,00	51 9019 €61,80	51 9019 €61,80	51 9019 €61,80	51 9019 €61,80	51 7075 *PG* €58,71	51 7075 *PG* €58,71	5111380 €66,95
6111246 €18,50	6111246 €18,50	61 9831 €19,49	6111246 €18,50	61 9831 €19,49	6112730 €14,36	6112730 €14,36	-
6114114 €38,76	6114114 €38,76	6114118 €38,25	6114114 €38,76	6114118 €38,25	6112729 €25,23	6112729 €25,23	6112959 €28,51
66 9420.M0 €10,00 gr.07,2	66 9420.M0 €10,00 gr.07,2	66 9420.M0 €10,00 gr.07,2	66 9420.M0 €10,00 gr.07,2	66 9420.M0 €10,00 gr.07,2	66 9823.M0 €9,50 gr.07	66 9823.M0 €9,50 gr.07	66 9420.J0 €10,00 gr.11
66 9420.N0 €10,00 gr.07,5	66 9420.N0 €10,00 gr.07,5	66 9420.I0 €10,00 gr.06,5	66 9420.N0 €10,00 gr.07,5	66 9420.I0 €10,00 gr.06,5	66 9417.F0 €7,24 gr.05,4	66 9417.F0 €7,24 gr.05,4	66 9417.N0 €7,24 gr.08,3
-	-	-	-	-	61 7152 €21,71	61 7152 €21,71	-
PG.438	PG.438	PG.438	PG.438	PG.438	PG.438	PG.438	2911388.Y0 *PG* €10,71
2512828 €4,45	2512828 €4,45	2512828 €4,45	2512828 €4,45	2512828 €4,45	2512827 €4,45	2512827 €4,45	2512827 €4,45
61 9100 €85,57	61 9100 €85,57	61 9100 €85,57	61 9100 €85,57	61 9100 €85,57	61 8312 Ø 33 €85,57 61 9223 Ø 34 €85,57	61 8312 Ø 33 €85,57 61 9223 Ø 34 €85,57	61 8312 €85,57
52 8797 €47,30	52 8797 €47,30	52 8797 €47,30	52 8797 €47,30	52 8797 €47,30	52 9450 €47,30	52 9450 €47,30	52 8798 €47,30
52 7880 €77,89	52 7880 €77,89	52 7880 €77,89	52 7880 €77,89	52 7880 €77,89	52 9451 €77,89	52 9451 €77,89	52 7879 €77,89
7711115 €22,60 Ø 107	7711115 €22,60 Ø 107	7711115 €22,60 Ø 107	7711115 €22,60 Ø 107	7711115 €22,60 Ø 107	7711124 €22,60 Ø 107	7711124 €22,60 Ø 107	-
7711207 €33,45 Ø 107	7711207 €33,45 Ø 107	7711207 €33,45 Ø 107	7711207 €33,45 Ø 107	7711207 €33,45 Ø 107	7711166 €33,45 Ø 107	7711166 €33,45 Ø 107	-
5214111 €63,00 Ø 107	5214111 €63,00 Ø 107	5214111 €63,00 Ø 107	5214111 €63,00 Ø 107	5214111 €63,00 Ø 107	5214112 €63,00 Ø 107	5214112 €63,00 Ø 107	-
5214110 €93,84 Ø 107	5214110 €93,84 Ø 107	5214110 €93,84 Ø 107	5214110 €93,84 Ø 107	5214110 €93,84 Ø 107	5214113 €93,84 Ø 107	5214113 €93,84 Ø 107	-
29 8746 €14,50	29 8746 €14,50	29 8746 €14,50	29 8746 €14,50	29 8746 €14,50	29 8746 €14,50	29 8746 €14,50	29 8746 €14,50
29 8747 €19,40	29 8747 €19,40	29 8747 €19,40	29 8747 €19,40	29 8747 €19,40	29 8747 €19,40	29 8747 €19,40	29 8747 €19,40
29 7454 €16,20	29 7454 €16,20	29 7454 €16,20	29 7454 €16,20	29 7454 €16,20	29 7714 €13,80 Ø 105	29 7714 €13,80 Ø 105	29 7715 €16,20
-	-	-	-	-	29 9605 €16,20 Ø 107	29 9605 €16,20 Ø 107	-

















MALOSSI

Scooter 2T

with ENGINE 

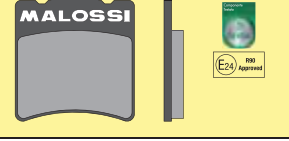
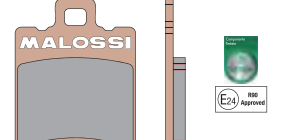
SYM			VESPA
DD	JET BasiX euro 2	JET SportX-S - SportX-R euro 2	ET2 <-1999
		(T5C/1)	
50 2T 	50 2T 	50 2T 	50 2T 

 CHECK "TYPE" SPECIFICATION (HOMOLOGATION MARK)

	CARBURETTOR		-	-	-	72 7084 €75,17 Ø 17,5
	CARBURETTOR KIT Ø 19		-	1613650 €112,10	1613650 €112,10	1611040 €118,04
	CARBURETTOR KIT Ø 21		-	-	-	1610997 €114,23
	CARBURETTOR KIT Ø 22		-	-	-	1611029 €96,77
	REED VALVE CARBON FIBRE		27 7440.C0 €49,00 VL9	-	-	27 7708.C0 €48,95 VL11
	PETALS SET FOR ORIGINAL REED VALVE		27 2728.C0 €16,27	27 1090.C0 €14,90	27 1090.C0 €14,90	27 7054.C0 €18,71
	ART OF PERFORMANCE / FLIP HOMOLOGATED  	PG. 426	-	-	-	-
	WILD LION HOMOLOGATED 	PG. 424	-	-	-	3216579 €87,00
	RED SPONGE FOR ORIGINAL AIR BOX		-	-	-	1411425 €4,45
	DOUBLE RED SPONGE FOR ORIGINAL AIR BOX		-	-	-	1414503 €6,65
	GEARS HTQ PRIMARY		-	6713709 €60,30 z 15/44	6713709 €60,30 z 15/44	67 8726 €71,11 z 15/38
	GEARS HTQ SECONDARY	PG. 478	-	-	-	PG.478
	ROLLER CRANKCASE		-	-	-	-
	SCREEN		-	-	-	-
	BRAKE PADS FRONT		-	6215856 €7,80 2005->08	6215856 €7,80 2006->10	6215049 €6,24 1997->
	BRAKE PADS MHR FRONT		-	-	-	6215074 €6,30 1997->
	BRAKE PADS MHR SYNT FRONT		-	-	-	6215006 €11,96 1997->
	BRAKE PADS REAR		-	-	-	-
	BRAKE PADS MHR REAR		-	-	-	-
	BRAKE PADS MHR SYNT REAR		-	-	-	-
	BRAKE POWER REAR		-	-	-	6215328 €18,39 1997->
	BRAKE SHOES FRONT		-	-	-	6212604 €76,38 1997->
	WHOOPE DISC FRONT		-	-	-	-
	WHOOPE DISC REAR		-	-	-	-
	RS1 - RS3 REAR SHOCK ABSORBER		-	-	-	4615432 €94,86 46 7908 €140,92
	RS24 - RS24/10 FRONT SHOCK ABSORBER		-	-	-	46 7900 €222,63
	RS24 - RS24/10 - RS24/10-R REAR SHOCK ABSORBER		-	-	-	46 8308 €248,50 4614237 €428,82
	RS24 FRONT + REAR		-	-	-	46 9031 €456,47
	HORQUILLA F32S FORK STEMS Ø 32		-	-	-	-
	HORQUILLA F37R MHR FORK STEMS Ø 37		-	-	-	-

15 - WITH manual choke

66 - NOT to be used on VEHICLE WITH ORIGINAL PRIMARY GEARS

82 - OVERSIZED WHOOP DISC KIT ext. Ø 250 - thickness 3 mm/ BRAKE CALIPER SUPP. CLAMP for ORIGINAL FORK, IS ALSO AVAILABLE: 6213297 € 189,95

VESPA					YAMAHA		
ET2 2000->	LX	Primavera euro 2	S euro 2	Sprint euro 2	AEROX euro 0-1	AEROX euro 2	AEROX
		(C533M)	(C381M)				
50 2T	50 2T	50 2T	50 2T	50 2T	50 2T	50 2T	100 2T
72 7084 € 75,17 Ø 17,5	72 7084 € 75,17 Ø 17,5	72 7084 € 75,17 Ø 17,5	72 7084 € 75,17 Ø 17,5	72 7084 € 75,17 Ø 17,5	72 8121 € 81,54 Ø 17,5	72 8121 € 81,54 Ø 17,5	-
1611040 € 118,04	1611040 € 118,04	1611040 € 118,04	1611040 € 118,04	1611040 € 118,04	1611042 € 118,04	1611042 € 118,04	-
1610997 € 114,23	1610997 € 114,23	1610997 € 114,23	1610997 € 114,23	1610997 € 114,23	1610995 € 114,23	1610995 € 114,23	-
1611029 € 96,77	1611029 € 96,77	1611029 € 96,77	1611029 € 96,77	1611029 € 96,77	1611026 *15* € 107,68	1611026 *15* € 107,68	1611430 € 174,96
27 7708.C0 € 48,95 VL11	27 7708.C0 € 48,95 VL11	27 7708.C0 € 48,95 VL11	27 7708.C0 € 48,95 VL11	27 7708.C0 € 48,95 VL11	27 7731.C0 € 48,95 VL12	27 7731.C0 € 48,95 VL12	27 7731.C0 € 48,95 VL12
27 7054.C0 € 18,71	27 7054.C0 € 18,71	27 7054.C0 € 18,71	27 7054.C0 € 18,71	27 7054.C0 € 18,71	27 7054.C0 € 18,71	27 7054.C0 € 18,71	27 7054.C0 € 18,71
-	-	-	-	-	3216691 € 122,00	3216691 € 122,00	-
3216579 € 87,00	3216579 € 87,00	-	-	-	3216583 € 87,00	3216583 € 87,00	-
1411425 € 4,45	1411778 € 3,54	1411778 € 3,54	1411778 € 3,54	1411778 € 3,54	1411412 € 3,64	1411412 € 3,64	-
1414503 € 6,65	1414497 € 6,16	1414497 € 6,16	1414497 € 6,16	1414497 € 6,16	1414498 € 5,73	1414498 € 5,73	-
6711449 z 16/37 € 60,41 6713339 z 15/38 € 61,71	6711449 z 16/37 € 60,41 6713339 z 15/38 € 61,71	6711449 z 16/37 € 60,41 6713339 z 15/38 € 61,71	6711449 z 16/37 € 60,41 6713339 z 15/38 € 61,71	6711449 z 16/37 € 60,41 6713339 z 15/38 € 61,71	6714039 € 57,67 z 13/44	6714039 € 57,67 z 13/44	6711486 € 76,18 z 15/42
67 9968 € 61,65 z 14/47	67 9968 € 61,65 z 14/47	67 9968 € 61,65 z 14/47	67 9968 € 61,65 z 14/47	67 9968 *PG* € 61,65 z 14/47	6714774 z 15/42 € 67,32 6714775 z 14/43 € 67,32	6714774 z 15/42 € 67,32 6714775 z 14/43 € 67,32	-
2514521 *66* € 95,00	2514521 *66* € 95,00	2514521 *66* € 95,00	2514521 *66* € 95,00	2514521 *66* € 95,00	2515482 € 95,00	2515482 € 95,00	-
-	4516054 € 73,80	4516332 € 75,00	-	4516342 € 75,00	-	-	-
6215049 € 6,24 1997->	-	6215062 € 8,32	6215049 € 6,24	6215062 € 8,32	6215043 € 5,80 1997->	6215043 € 5,80	6215043 € 5,80 2000->
6215074 € 6,30 1997->	-	6215079 € 8,20	6215074 € 6,30	6215079 € 8,20	62 9083 € 6,20 1997->	62 9083 € 6,20	62 9083 € 6,20 2000->
6215006 € 11,96 1997->	-	6215013 € 16,50	6215006 € 11,96	6215013 € 16,50	6215008 € 11,96 1997->	6215008 € 11,96	6215008 € 11,96 2000->
-	-	-	-	-	-	6215058 € 6,55	-
-	-	-	-	-	-	-	-
-	-	-	-	-	-	-	-
6215328 € 18,39 1997->	6215328 € 18,39	6215328 € 18,39	6215328 € 18,39	6215328 € 18,39	-	-	-
6212604 € 76,38 1997->	-	6212604 € 76,38	6212604 € 76,38	6212604 € 76,38	6213292 *82* € 72,56	6213292 *82* € 72,56	-
-	-	-	-	-	-	-	-
4615432 € 94,86 46 7908 € 140,92	-	-	4615432 € 94,86 46 7908 € 140,92	-	4615432 € 94,86 46 7908 € 140,92	4615432 € 94,86 46 7908 € 140,92	-
46 7900 € 222,63	-	-	46 7900 € 222,63 46 8298 € 357,00	-	-	-	-
46 8308 € 248,50 4614237 € 428,82	-	-	46 8308 € 248,50 4614237 € 428,82	-	46 8611 € 219,76	46 8611 € 219,76	-
46 9031 € 456,47	-	-	46 9031 € 456,47	-	-	-	-
-	-	-	-	-	-	-	-
-	-	-	-	-	-	-	-



MALOSSI

Scooter 2T

with ENGINE 

YAMAHA

AXIS

BREEZE

BW'S
euro 0-1BW'S
euro 2

(A137E)

(▲) ATTENTION: ONLY FOR vehicles WITHOUT IMMOBILIZER KEY

		50 2T	 50 2T	 50 2T	 50 2T
	CYLINDER+HEAD CAST-IRON Ø 40	31 8562 1	31 8562 1	31 6901 1	31 6901 1
	(pin) ALUMINIUM Ø 40-41	€120,74 Ø 40 (10)	€120,74 Ø 40 (10)	€120,72 Ø 40 (10)	€120,72 Ø 40 (10)
	CYLINDER+HEAD	31 7083 1	31 7083 1	31 7237 1	31 7237 1
	(pin) CAST-IRON Ø 47	€114,25 Ø 47 (10)	€114,25 Ø 47 (10)	€112,27 Ø 47 (10)	€112,27 Ø 47 (10)
	CYLINDER CAST-IRON Ø 47-57,5	31 7002	31 7002	31 6882	31 6882
for ORIGINAL HEAD ALUM. Ø 47>57,5	€97,90 Ø 47 (10)	€97,90 Ø 47 (10)	€97,90 Ø 47 (10)	€97,90 Ø 47 (10)	
HEAD HTSR	38 7246	38 7246	3812770	3812770	
for Malossi CYLINDER	€37,47 Ø 47	€37,47 Ø 47	€37,47 Ø 47	€37,47 Ø 47	
CYLINDER+HEAD MHR Replica ALUMINIUM	31 8437 1	31 8437 1	31 8501 1	31 8501 1	
(pin) Ø 47	€207,00 Ø 47 (10)	€207,00 Ø 47 (10)	€201,93 Ø 47 (10)	€201,93 Ø 47 (10)	
	CRANKSHAFTS RHQ	53 7891	53 7891	53 7621	53 7621
	PIN Ø 10	€175,50	€175,50	€175,50	€175,50
	CRANKSHAFTS RHQ	53 8009	53 8009	53 8008	53 8008
	PIN Ø 12	€175,50	€175,50	€163,04	€163,04
	RADIAL ROLLER BEARING FOR CRANKSHAFT	PG.473	PG.473	PG.473	PG.473
	ELECTRONIC CONTROLLER	55 7447	55 8133	55 8133	-
		€65,21	€50,14	€50,14	-
	ELECTRONIC CONTROLLER RPM CONTROL	-	55 8676	55 8676	5512790
		-	€97,59	€97,59	€157,87
	MULTIVAR VARIATOR	51 7075	51 7075	51 7075	51 7075
		€58,71	€58,71	€58,71	€58,71
	X SPECIAL BELT BELT	6112741	6112741	6112730	6112730
		€15,25	€15,25	€14,36	€14,36
	X K BELT BELT	6112742	6112742	6112729	6112729
	€26,33	€26,33	€25,23	€25,23	
	HTRoll ROLLERS FOR MULTIVAR	66 9823.M0	66 9823.M0	66 9823.M0	66 9823.M0
		€9,50 gr.07	€9,50 gr.07	€9,50 gr.07	€9,50 gr.07
	HTRoll ROLLERS FOR ORIGINAL VARIATOR	66 9417.H0	66 9417.I0	66 9417.H0	66 9417.F0
	€7,24 gr.06,5	€7,24 gr.06,8	€7,24 gr.06,5	€7,24 gr.05,4	
	VENTILVAR FIXED HALF-PULLEY	61 7152	61 7152	61 7152	61 7152
	€21,71	€21,71	€21,71	€21,71	
	VARIABLE-SPEED DRIVE ADJUSTER SPRING FOR VARIATOR	PG.438	PG.438	PG.438	PG.438
	TORSION CONTROLLER ANTIFRICTION FIFTH WHEEL	2512827	2512827	2512827	2512827
		€4,45	€4,45	€4,45	€4,45
	TORQUE DRIVER MOBILE DRIVEN SPLIT PULLEY	61 8312	61 8312 Ø 33 €85,57	61 8312 Ø 33 €85,57	6112766
		€85,57	€85,57	€85,57	€83,89
	FLY CLUTCH NOT ADJUSTABLE CLUTCH	52 8798	52 8798	52 8796 Ø 105 €53,26	52 8797
		€47,30	€47,30	€47,30	€47,30
	DELTA CLUTCH ADJUSTABLE CLUTCH	52 7879	52 7879	52 7643 Ø 105 €77,89	52 7880
		€77,89	€77,89	€77,89	€77,89
	CLUTCH BELL CLUTCH BELL (SMOOTH RING)	-	-	7711124	7711124
		-	-	€22,60 Ø 107	€22,60 Ø 107
	WING CLUTCH BELL CLUTCH BELL (FINNED RING)	-	-	7711166	7711166
		-	-	€33,45 Ø 107	€33,45 Ø 107
	FLY SYSTEM CLUTCH BELL + NOT ADJUSTABLE CLUTCH	-	-	5214112	-
		-	-	€63,00 Ø 107	-
	DELTA SYSTEM CLUTCH BELL + ADJUSTABLE CLUTCH	-	-	5214113	-
		-	-	€93,84 Ø 107	-
	SPORT SPRINGS FOR FLY / DELTA CLUTCH	29 8746	29 8746	29 8746	29 8746
		€14,50	€14,50	€14,50	€14,50
	MHR SPRINGS FOR FLY / DELTA CLUTCH	29 8747	29 8747	29 8747	29 8747
		€19,40	€19,40	€19,40	€19,40
	SPRINGS Ø INTERNAL CLUTCH BELL 105-107 FOR ORIGINAL CLUTCH	29 7714 Ø 105 €13,80	29 7714 Ø 105 €13,80	29 7714	29 7454
	29 9605 Ø 107 €16,20	29 9605 Ø 107 €16,20	€13,80 Ø 105	€16,20	
MUELLES Ø INTERNAL CLUTCH BELL 112 FOR ORIGINAL CLUTCH	29 7715	29 7715	29 9605	-	
	€16,20 Ø 112	€16,20 Ø 112	€16,20 Ø 107	-	

PG - SPECIFICATIONS on the PAGE indicated in the TITLE of the LINE



MALOSS

Scooter 2T

with ENGINE 

YAMAHA

AXIS

BREEZE

BW'S
euro 0-1BW'S
euro 2

50 2T



50 2T

















50 2T

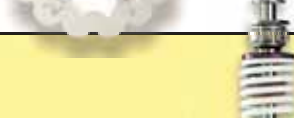

50 2T

**(■) CHECK "TYPE" SPECIFICATION (HOMOLOGATION MARK)**

	CARBURETTOR		72 9215 € 78,76 Ø 17,5	72 9215 € 78,76 Ø 17,5	72 8121 Ø 17,5 € 81,54 72 7085 Ø 16 € 80,08	72 8121 € 81,54 Ø 17,5
	CARBURETTOR KIT	Ø 19	1611042 € 118,04	1611042 € 118,04	1611024 € 97,95	1611024 € 97,95
	CARBURETTOR KIT	Ø 21	1610998 € 116,64	1610995 € 114,23	1610985 € 93,98	1610985 € 93,98
	CARBURETTOR KIT	Ø 22	1611031 € 120,28	1611031 € 120,28	-	-
	REED VALVE CARBON FIBRE		27 7731.C0 € 48,95 VL12	27 7731.C0 € 48,95 VL12	27 7441.C0 € 46,02 VL10	27 7441.C0 € 46,02 VL10
	PETALS SET FOR ORIGINAL REED VALVE		27 7054.C0 € 18,71	27 7054.C0 € 18,71	27 3549.C0 € 16,19	27 3549.C0 € 16,19
	ART OF PERFORMANCE / FLIP HOMOLOGATED 	PG. 426	-	-	3215170 € 175,70 3216693 € 122,00	3215170 € 175,70 3216693 € 122,00
	WILD LION HOMOLOGATED 	PG. 424	3216587 € 87,00	-	3216586 € 87,00	3216586 € 87,00
	RED SPONGE FOR ORIGINAL AIR BOX		1411412 € 3,64	1411412 € 3,64	1411414 € 4,05	1411414 € 4,05
	DOUBLE RED SPONGE FOR ORIGINAL AIR BOX		1414498 € 5,73	1414498 € 5,73	1414495 € 7,62	1414495 € 7,62
	GEARS HTQ PRIMARY		67 7324 € 67,90 z 17/40	67 7014 € 68,44 z 15/41	67 3677 € 57,67 z 16/40	67 3677 € 57,67 z 16/40
	GEARS HTQ SECONDARY	PG. 478	-	-	-	-
	ROLLER CRANKCASE		-	-	2515482 € 95,00	2515482 € 95,00
	SCREEN		-	-	-	-
	BRAKE PADS	FRONT	6215044 € 6,97 1993->	6215042 € 5,72 1994->	6215042 € 5,72 1995->	6215042 € 5,72
	BRAKE PADS MHR	FRONT	62 9084 € 6,90 1993->	6215080 € 6,00 1994->	6215080 € 6,00 1995->	6215080 € 6,00
	BRAKE PADS MHR SYNT	FRONT	-	6215007 € 11,96 1994->	6215007 € 11,96 1995->	6215007 € 11,96
	BRAKE PADS	REAR	-	-	-	-
	BRAKE PADS MHR	REAR	-	-	-	-
	BRAKE PADS MHR SYNT	REAR	-	-	-	-
	BRAKE POWER	REAR	6215834	6215834	6215834	6215834
	BRAKE SHOES	FRONT	€ 21,50 1993->	€ 21,50 1994->	€ 21,50 1995->	€ 21,50
	WHOOP DISC	FRONT	-	6214097 € 62,00 1994->	-	62 8961 € 73,03
	WHOOP DISC	REAR	-	-	-	-
	RS1 - RS3	REAR SHOCK ABSORBER	4615434 € 88,74	4615434 € 88,74	4615434 € 88,74	46 7905 € 140,92
	RS24 - RS24/10	FRONT SHOCK ABSORBER	-	-	-	-
	RS24 - RS24/10 - RS24/10-R	REAR SHOCK ABSORBER	46 7591 € 230,79	46 7591 € 230,79	46 7591 € 230,79	46 7588 € 255,97
	RS24	FRONT + REAR	-	-	-	-
	HORQUILLA F32S	FORK STEMS Ø 32	-	-	-	-
	HORQUILLA F37R MHR	FORK STEMS Ø 37	-	-	-	-

15 - WITH manual choke

YAMAHA

BW'S NG euro 0-1		BW'S NG euro 2		BW'S Original/ Naked euro 2 2010->		BW'S		CRZ		JOG		JOG ER		JOG R	
		(A137E)		(A137E)											
50 2T	🔊	50 2T	🔊	50 2T	🔊	100 2T	🔊	50 2T	🔊	50 2T	🔊	50 2T	🔊	50 2T	🔊
72 8121 € 81,54 Ø 17,5	72 8121 € 81,54 Ø 17,5	72 8121 € 81,54 Ø 17,5	-	72 9215 € 78,76 Ø 17,5	-	-	72 8121 € 81,54 Ø 17,5								
1611024 € 97,95	1611024 € 97,95	1611024 € 97,95	-	-	1611042 € 118,04	1611042 € 118,04	1611042 € 118,04								
1610985 € 93,98	1610985 € 93,98	1610985 € 93,98	-	-	1610998 € 116,64	1610998 € 116,64	1610995 € 114,23								
-	-	-	1611430 € 174,96	-	1611031 € 120,28	1611031 € 120,28	1611026 *15* € 107,68								
27 7441.C0 € 46,02 VL10	27 7441.C0 € 46,02 VL10	27 7441.C0 € 46,02 VL10	27 7731.C0 € 48,95 VL12	27 7441.C0 € 46,02 VL10	27 7731.C0 € 48,95 VL12	27 7731.C0 € 48,95 VL12	27 7731.C0 € 48,95 VL12								
27 3549.C0 € 16,19	27 3549.C0 € 16,19	27 3549.C0 € 16,19	27 7054.C0 € 18,71	27 3549.C0 € 16,19	27 7054.C0 € 18,71	27 7054.C0 € 18,71	27 7054.C0 € 18,71								
3215170 € 175,70 3216693 € 122,00	3215170 € 175,70 3216693 € 122,00	3215170 € 175,70 3216693 € 122,00	-	-	-	-	-								
3216586 € 87,00	-	3216586 € 87,00	-	-	3216587 € 87,00	3216587 € 87,00	3216587 € 87,00								
1411414 € 4,05	1411414 € 4,05	1411414 € 4,05	-	-	1411412 € 3,64	-	1411412 € 3,64								
1414495 € 7,62	1414495 € 7,62	1414495 € 7,62	-	-	1414498 € 5,73	-	1414498 € 5,73								
67 3677 € 57,67 z 16/40	67 3677 € 57,67 z 16/40	67 3677 € 57,67 z 16/40	6711486 € 76,18 z 15/42	-	67 7324 € 67,90 z 17/40	67 7324 € 67,90 z 17/40	6714039 € 57,67 z 13/44								
-	-	-	-	-	-	-	6714774 z 15/42 € 67,32 6714775 z 14/43 € 67,32								
2515482 € 95,00	2515482 € 95,00	2515482 € 95,00	-	-	-	-	2515482 € 95,00								
-	-	-	-	-	-	-	-								
6215042 € 5,72 1995->	6215042 € 5,72	6215042 € 5,72	6215044 € 6,97 2000->	6215044 € 6,97 1992->	6215044 € 6,97 1993->	6215044 € 6,97 1993->	6215043 € 5,80 1993->								
6215080 € 6,00 1995->	6215080 € 6,00	6215080 € 6,00	62 9084 € 6,90 2000->	62 9084 € 6,90 1992->	62 9084 € 6,90 1993->	62 9084 € 6,90 1993->	62 9083 € 6,20 1993->								
6215007 € 11,96 1995->	6215007 € 11,96	6215007 € 11,96	-	-	-	-	6215008 € 11,96 1993->								
-	-	-	-	-	-	-	-								
-	-	-	-	-	-	-	-								
-	-	-	-	-	-	-	-								
6215834 € 21,50 1995->	6215834 € 21,50	6215834 € 21,50	-	6215834 € 21,50 1992->	6215834 € 21,50 1993->	6215834 € 21,50 1993->	6215834 € 21,50 1993->								
62 8961 € 73,03 1995->	62 8961 € 73,03	62 8961 € 73,03	-	6214097 € 62,00 1992->	-	-	6212603 € 72,56 1993->								
-	-	-	-	-	-	-	-								
4615434 € 88,74	46 7905 € 140,92	46 7905 € 140,92	-	4615434 € 88,74	4615434 € 88,74	4615434 € 88,74	4615433 € 90,78 46 8610 € 141,25								
-	-	-	-	-	-	-	-								
46 7591 € 230,79	46 7588 € 255,97	46 7588 € 255,97	-	46 7591 € 230,79	46 7591 € 230,79	46 7591 € 230,79	46 8611 € 219,76								
-	-	-	-	-	-	-	-								
-	-	-	-	-	-	-	-								
-	-	-	-	-	-	-	-								



MALOSSI

Scooter 2T

with ENGINE 

YAMAHA

JOGRR euro 2

NEO'S

NEO'S

SLIDER

(▲) ATTENTION: ONLY FOR vehicles WITHOUT IMMOBILIZER KEY

50 2T

LC

50 2T



100 2T



50 2T



	CYLINDER+HEAD CAST-IRON Ø 40	31 8556	1	31 8562	1	-	31 6901	1
	(pin) ALUMINIUM Ø 40-41	€161,98	Ø 40 (10)	€120,74	Ø 40 (10)	-	€120,72	Ø 40 (10)
	CYLINDER+HEAD	31 8284	1	31 7083	1	-	31 7237	1
	(pin) CAST-IRON Ø 47	€152,41	Ø 47 (10)	€114,25	Ø 47 (10)	-	€112,27	Ø 47 (10)
	CYLINDER CAST-IRON Ø 47-57,5	-	-	31 7002	-	3111374	31 6882	-
	for ORIGINAL HEAD ALUM. Ø 47>57,5	-	-	€97,90	Ø 47 (10)	€167,85	Ø 57,5 (14)	€97,90
	HEAD HTSR	-	-	38 7246	-	-	3812770	-
	for Malossi CYLINDER	-	-	€37,47	Ø 47	-	€37,47	Ø 47
	CYLINDER+HEAD MHR Replica ALUMINIUM	31 8430	1	31 8437	1	-	31 8501	1
	(pin) Ø 47	€228,06	Ø 47 (10)	€207,00	Ø 47 (10)	-	€201,93	Ø 47 (10)
	CRANKSHAFTS RHQ	53 7891	-	53 7891	-	-	53 7621	-
	PIN Ø 10	€175,50	-	€175,50	-	-	€175,50	-
	CRANKSHAFTS RHQ	53 8009	-	53 8009	-	-	53 8008	-
	PIN Ø 12	€175,50	-	€175,50	-	-	€163,04	-
	RADIAL ROLLER BEARING FOR CRANKSHAFT	PG. 473	-	PG.473	-	-	PG.473	-
	ELECTRONIC CONTROLLER	-	-	55 8133	-	-	55 8133	-
	(▲)	-	-	€50,14	euro 0-1	-	€50,14	-
	ELECTRONIC CONTROLLER RPM CONTROL	-	-	55 8676	euro 0-1 €97,59	-	55 8676	-
	(▲)	-	-	5512790	euro 2 €157,87	-	€97,59	-
	MULTIVAR VARIATOR	51 7075	-	51 7075	-	5111380	51 7075	-
		€58,71	-	€58,71	-	€66,95	€58,71	-
	X SPECIAL BELT BELT	6112730	-	6112730	-	-	6112730	-
		€14,36	-	€14,36	-	-	€14,36	-
	X K BELT BELT	6112729	-	6112729	-	6112959	6112729	-
		€25,23	-	€25,23	-	€28,51	€25,23	-
	HTRoll ROLLERS FOR MULTIVAR	66 9823.M0	-	66 9823.M0	-	66 9420.J0	66 9823.M0	-
		€9,50	gr.07	€9,50	gr.07	€10,00	gr.11	€9,50
	HTRoll ROLLERS FOR ORIGINAL VARIATOR	66 9417.F0	-	66 9417.H0	-	66 9417.N0	66 9417.H0	-
		€7,24	gr.05,4	€7,24	gr.06,5	€7,24	gr.08,3	€7,24
	VENTILVAR FIXED HALF-PULLEY	61 7152	-	61 7152	-	-	61 7152	-
		€21,71	-	€21,71	-	-	€21,71	-
	VARIABLE-SPEED DRIVE ADJUSTER SPRING FOR VARIATOR	PG. 438	-	PG.438	-	2911388.Y0 *PG*	PG.438	-
		-	-	-	-	€10,71	-	-
	TORSION CONTROLLER ANTIFRICTION FIFTH WHEEL	2512827	-	2512827	-	2512827	2512827	-
		€4,45	-	€4,45	-	€4,45	€4,45	-
	TORQUE DRIVER MOBILE DRIVEN SPLIT PULLEY	61 8312 Ø 33 €85,57	-	61 8312 Ø 33 €85,57	-	61 8312	61 8312 Ø 33 €85,57	-
		61 9223 Ø 34 €85,57	-	61 9223 Ø 34 €85,57	-	€85,57	61 9223 Ø 34 €85,57	-
	FLY CLUTCH NOT ADJUSTABLE CLUTCH	52 9450	-	52 9450	-	52 8798	52 9450	-
		€47,30	-	€47,30	-	€47,30	€47,30	-
	DELTA CLUTCH ADJUSTABLE CLUTCH	52 9451	-	52 9451	-	52 7879	52 9451	-
		€77,89	-	€77,89	-	€77,89	€77,89	-
	CLUTCH BELL CLUTCH BELL (SMOOTH RING)	7711124	-	7711124	-	-	7711124	-
		€22,60	Ø 107	€22,60	Ø 107	-	€22,60	Ø 107
	WING CLUTCH BELL CLUTCH BELL (FINNED RING)	7711166	-	7711166	-	-	7711166	-
		€33,45	Ø 107	€33,45	Ø 107	-	€33,45	Ø 107
	FLY SYSTEM CLUTCH BELL + NOT ADJUSTABLE CLUTCH	5214112	-	5214112	-	-	5214112	-
		€63,00	Ø 107	€63,00	Ø 107	-	€63,00	Ø 107
	DELTA SYSTEM CLUTCH BELL + ADJUSTABLE CLUTCH	5214113	-	5214113	-	-	5214113	-
		€93,84	Ø 107	€93,84	Ø 107	-	€93,84	Ø 107
	SPORT SPRINGS FOR FLY / DELTA CLUTCH	29 8746	-	29 8746	-	29 8746	29 8746	-
		€14,50	-	€14,50	-	€14,50	€14,50	-
	MHR SPRINGS FOR FLY / DELTA CLUTCH	29 8747	-	29 8747	-	29 8747	29 8747	-
		€19,40	-	€19,40	-	€19,40	€19,40	-
	SPRINGS Ø INTERNAL CLUTCH BELL 105-107 FOR ORIGINAL CLUTCH	29 7714	-	29 7714	-	29 7715	-	-
		€13,80	Ø 105	€13,80	Ø 105	€16,20	-	-
	MUELLES Ø INTERNAL CLUTCH BELL 112 FOR ORIGINAL CLUTCH	29 9605	-	29 9605	-	-	-	-
		€16,20	Ø 107	€16,20	Ø 107	-	-	-

PG - SPECIFICATIONS on the PAGE indicated in the TITLE of the LINE

YAMAHA

SPY	VINO	WHY	ZEST				

50 2T	50 2T	50 2T	50 2T				
31 6901 1 €120,72 Ø 40 (10)	31 8562 1 €120,74 Ø 40 (10)	31 8562 1 €120,74 Ø 40 (10)	31 8562 1 €120,74 Ø 40 (10)	-	-	-	-
31 7237 1 €112,27 Ø 47 (10)	31 7083 1 €114,25 Ø 47 (10)	31 7083 1 €114,25 Ø 47 (10)	31 7083 1 €114,25 Ø 47 (10)	-	-	-	-
31 6882 €97,90 Ø 47 (10)	31 7002 €97,90 Ø 47 (10)	31 7002 €97,90 Ø 47 (10)	31 7002 €97,90 Ø 47 (10)	-	-	-	-
3812770 €37,47 Ø 47	38 7246 €37,47 Ø 47	38 7246 €37,47 Ø 47	38 7246 €37,47 Ø 47	-	-	-	-
31 8501 1 €201,93 Ø 47 (10)	31 8437 1 €207,00 Ø 47 (10)	31 8437 1 €207,00 Ø 47 (10)	31 8437 1 €207,00 Ø 47 (10)	-	-	-	-
53 7621 €175,50	53 7891 €175,50	53 7891 €175,50	53 7891 €175,50	-	-	-	-
53 8008 €163,04	53 8009 €175,50	53 8009 €175,50	53 8009 €175,50	-	-	-	-
PG.473	PG.473	PG.473	PG.473	-	-	-	-
55 8133 €50,14	-	55 8133 €50,14 euro 0-1	55 8133 €50,14	-	-	-	-
55 8676 €97,59	-	55 8676 euro 0-1 €97,59 5512790 euro 2 €157,87	55 8676 €97,59	-	-	-	-
51 7075 €58,71	51 7075 €58,71	51 7075 €58,71	51 7075 €58,71	-	-	-	-
6112730 €14,36	6112741 €15,25	6112730 €14,36	6112741 €15,25	-	-	-	-
6112729 €25,23	6112742 €26,33	6112729 €25,23	6112742 €26,33	-	-	-	-
66 9823.M0 €9,50 gr.07	66 9823.M0 €9,50 gr.07	66 9823.M0 €9,50 gr.07	66 9823.M0 €9,50 gr.07	-	-	-	-
66 9417.I0 €7,24 gr.06,8	66 9417.H0 €7,24 gr.06,5	66 9417.H0 €7,24 gr.06,5	66 9417.L0 €7,24 gr.07,2	-	-	-	-
61 7152 €21,71	61 7152 €21,71	61 7152 €21,71	61 7152 €21,71	-	-	-	-
PG.438	-	PG.438	PG.438	-	-	-	-
2512827 €4,45	2512827 €4,45	2512827 €4,45	2512827 €4,45	-	-	-	-
61 8312 Ø 33 €85,57 61 9223 Ø 34 €85,57	61 8312 Ø 33 €85,57 61 9223 Ø 34 €85,57	61 8312 Ø 33 €85,57 61 9223 Ø 34 €85,57	61 8312 Ø 33 €85,57 61 9223 Ø 34 €85,57	-	-	-	-
52 8796 Ø 105 €53,26 52 9450 Ø 107 €47,30	52 9450 €47,30	52 9450 €47,30	52 8798 €47,30	-	-	-	-
52 7643 Ø 105 €77,89 52 9451 Ø 107 €77,89	52 9451 €77,89	52 9451 €77,89	52 7879 €77,89	-	-	-	-
7711124 €22,60 Ø 107	7711124 €22,60 Ø 107	7711124 €22,60 Ø 107	-	-	-	-	-
7711166 €33,45 Ø 107	7711166 €33,45 Ø 107	7711166 €33,45 Ø 107	-	-	-	-	-
5214112 €63,00 Ø 107	5214112 €63,00 Ø 107	5214112 €63,00 Ø 107	-	-	-	-	-
5214113 €93,84 Ø 107	5214113 €93,84 Ø 107	5214113 €93,84 Ø 107	-	-	-	-	-
29 8746 €14,50	29 8746 €14,50	29 8746 €14,50	29 8746 €14,50	-	-	-	-
29 8747 €19,40	29 8747 €19,40	29 8747 €19,40	29 8747 €19,40	-	-	-	-
29 7714 €13,80 Ø 105	29 7714 €13,80 Ø 105	29 7714 €13,80 Ø 105	29 7714 Ø 105 €13,80 29 9605 Ø 107 €16,20	-	-	-	-
29 9605 €16,20 Ø 107	29 9605 €16,20 Ø 107	29 9605 €16,20 Ø 107	29 7715 €16,20 Ø 112	-	-	-	-



MALOSSİ

Scooter 2T

with ENGINE 

YAMAHA

JOGRR
euro 2

NEO'S

NEO'S

SLIDER

50 2T















LC

50 2T

100 2T

50 2T

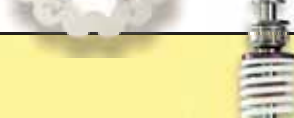
 CHECK "TYPE" SPECIFICATION (HOMOLOGATION MARK)

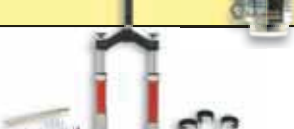
	CARBURETTOR		72 8121 € 81,54 Ø 17,5	72 8121 € 81,54 Ø 17,5	-	72 8121 € 81,54 Ø 17,5
	CARBURETTOR KIT	Ø 19	1611042 € 118,04	1611042 € 118,04	-	1611024 € 97,95
	CARBURETTOR KIT	Ø 21	1610995 € 114,23	1610995 € 114,23	-	1610985 € 93,98
	CARBURETTOR KIT	Ø 22	1611026 *15* € 107,68	1611026 *15* € 107,68	1611430 € 174,96	-
	REED VALVE CARBON FIBRE		27 7731.C0 € 48,95 VL12	27 7731.C0 € 48,95 VL12	27 7731.C0 € 48,95 VL12	27 7441.C0 € 46,02 VL10
	PETALS SET FOR ORIGINAL REED VALVE		27 7054.C0 € 18,71	27 7054.C0 € 18,71	27 7054.C0 € 18,71	27 3549.C0 € 16,19
	ART OF PERFORMANCE / FLIP HOMOLOGATED 		PG. 426 3216691 € 122,00	-	-	-
	WILD LION HOMOLOGATED 		PG. 424 -	3216588 € 87,00	-	3216586 € 87,00
	RED SPONGE FOR ORIGINAL AIR BOX		1411412 € 3,64	1411412 € 3,64	-	-
	DOUBLE RED SPONGE FOR ORIGINAL AIR BOX		1414498 € 5,73	1414498 € 5,73	-	-
	GEARS HTQ PRIMARY		6714039 € 57,67 z 13/44	6714039 € 57,67 z 13/44	6711486 € 76,18 z 15/42	67 3677 € 57,67 z 16/40
	GEARS HTQ SECONDARY		PG. 478 6714774 z 15/42 € 67,32 6714775 z 14/43 € 67,32	6714774 z 15/42 € 67,32 6714775 z 14/43 € 67,32	-	-
	ROLLER CRANKCASE		2515482 € 95,00	2515482 € 95,00	-	2515482 € 95,00
	SCREEN		-	-	-	-
	BRAKE PADS	FRONT	-	6215043 € 5,80 1997->	6215043 € 5,80 2000->	6215042 € 5,72 2000->
	BRAKE PADS MHR	FRONT	-	62 9083 € 6,20 1997->	62 9083 € 6,20 2000->	6215080 € 6,00 2000->
	BRAKE PADS MHR SYNT	FRONT	-	6215008 € 11,96 1997->	6215008 € 11,96 2000->	6215007 € 11,96 2000->
	BRAKE PADS	REAR	-	-	-	-
	BRAKE PADS MHR	REAR	-	-	-	-
	BRAKE PADS MHR SYNT	REAR	-	-	-	-
	BRAKE POWER	REAR	-	6215834	-	6215834
	BRAKE SHOES	FRONT	-	€ 21,50 1997->	-	€ 21,50 2000->
	WHOOPIE DISC	FRONT	-	6212603 € 72,56 1997->	-	6212603 € 72,56 2000->
	WHOOPIE DISC	REAR	-	-	-	-
	RS1 - RS3	REAR SHOCK ABSORBER	-	4615433 € 90,78 46 8610 € 141,25	-	-
	RS24 - RS24/10	FRONT SHOCK ABSORBER	-	-	-	-
	RS24 - RS24/10 - RS24/10-R	REAR SHOCK ABSORBER	-	46 8611 € 219,76	-	-
	RS24	FRONT + REAR	-	-	-	-
	HORQUILLA F32S	FORK STEMS Ø 32	-	-	-	-
	HORQUILLA F37R MHR	FORK STEMS Ø 37	-	-	-	-

15 - WITH manual choke



Art. 5512894

€ 210,11



This ECU (Electronic Control Unit) converts your fuel injected vehicle into a carburettored vehicle. In addition to the ECU, a carburettor and a specific cylinder and head, designed for a carburettor, are required (see articles in the red frame -->).

An amazing development

The first Electronic Control Unit (ECU) capable of converting a fuel injection system into a carburettor system has been developed:

DIGITRONIC K.R.M.

As of today, with K.R.M, it is possible for any 50cc two-stroke fuel injected scooter to utilise a vast assortment of Malossi carburettor-based products. You can have a racing scooter with winning potential and even participate in the Trophy Series Malossi sponsors in all Europe.

The kit Digitronic K.R.M. consists of an ECU and mounting hardware. The ECU simply substitutes the original ECU and is connected to the existent wiring. No other modifications are required.

The ECU K.R.M. has been developed by a team of Malossi engineers, with the goal to create a product capable of guaranteeing the maximum satisfaction from our most demanding customers!

NOTE:

now your vehicle will be identical to a carburettored vehicle, in which you can install any spare part made for such vehicles (see the following comparative tables).

with ENGINE 

APRILIA

GILERA

SR R FACTORY
SR DITECH GP1

SR DITECH

RUNNER
Purejet
<-2005

RUNNER
Purejet
2006->

(PIAGGIO C361M)

(APRILIA)

50 2T LC

50 2T LC

50 2T LC







50 2T LC

DIGITRONIC K.R.M.

5512894

€ 210,11

This ECU (Electronic Control Unit) converts your fuel injected vehicle into a carburettored vehicle. In addition to the ECU, a carburettor and a specific cylinder and head, designed for a carburettor, are required. (see articles in the red frame -->)

	CYLINDER+HEAD (pin Ø 12)	CAST-IRON Ø 40 ALUMINIUM Ø 40	31 8523 € 164,21	-	31 8523 € 164,21	31 8523 € 164,21
	CYLINDER+HEAD (pin Ø 12)	CAST-IRON Ø 47	31 7353 € 176,03	31 9541 € 166,72	31 7353 € 176,03	31 7353 € 176,03
	CYLINDER for ORIGINAL HEAD	CAST-IRON Ø 47	-	-	-	-
	HEAD HTSR for Malossi CYLINDER		-	-	-	-
	CYLINDER+HEAD MHR Replica (pin Ø 12)	ALUMINIUM Ø 47-Ø 47,6	31 8466 € 239,46	-	31 8466 € 239,46	31 8466 € 239,46
	CRANKSHAFT RHQ (carb.)	PIN Ø 12	53 7600 € 175,50	-	53 7600 € 175,50	53 7600 € 175,50
	(inject.)	PIN Ø 12	5312331 € 301,56	5312582 € 280,16	5312331 € 301,56	5312331 € 301,56
	GEARS HTQ		67 9080 z 14/39 € 60,41	6711297	67 9080 z 14/39 € 60,41	67 9080 z 14/39 € 60,41
	PRIMARY		6713339 z 15/38 € 61,71	€ 121,34 z 15/40	6713339 z 15/38 € 61,71	6713339 z 15/38 € 61,71
	ART OF PERFORMANCE / FLIP HOMOLOGATED	 Pg. 426	3216694 € 122,00	-	3215167 € 175,70 3216692 € 122,00	-
	REED VALVE CARBON FIBRE		27 7708.CO € 48,95 VL11	27 7731.CO € 48,95 VL12	27 7708.CO € 48,95 VL11	27 7708.CO € 48,95 VL11
	CARBURETTOR	Ø 17,5	72 7084 € 75,17	-	72 7084 € 75,17	72 7084 € 75,17
	CARBURETTOR KIT	Ø 19	1611040 € 118,04	1611039 € 124,50	1611040 € 118,04	1611040 € 118,04
		Ø 21	1610997 € 114,23	-	1610997 € 114,23	1610997 € 114,23
		Ø 22	1611029 € 96,77	-	1611029 € 96,77	1611029 € 96,77
	MULTIVAR VARIATOR		51 9019 € 61,80	5111561 € 59,36	51 9019 € 61,80	51 9019 € 61,80
	X SPECIAL BELT BELT	Pg. 452	61 9831 € 19,49	6111295 € 17,71	61 9831 € 19,49	61 9831 € 19,49
	X K BELT BELT		6114118 € 38,25	6111294 € 28,38	6114118 € 38,25	6114118 € 38,25
	TORQUE DRIVER MOBILE DRIVEN SPLIT PULLEY		61 9100 € 85,57	-	61 9100 € 85,57	61 9100 € 85,57
	FLY CLUTCH NOT ADJUSTABLE CLUTCH		52 8797 *K3* € 47,30	52 9450 € 47,30	52 8797 *K3* € 47,30	52 8797 *K3* € 47,30
	DELTA CLUTCH ADJUSTABLE CLUTCH		52 7880 *K4* € 77,89	52 9451 € 77,89	52 7880 *K4* € 77,89	52 7880 *K4* € 77,89
	CLUTCH BELL CLUTCH BELL (SMOOTH RING)	Ø 107	7711115 *K3* € 22,60	-	7711115 *K3* € 22,60	7711115 *K3* € 22,60
	WING CLUTCH BELL CLUTCH BELL (FINNED RING)	Ø 107	7711207 *K4* € 33,45	-	7711207 *K4* € 33,45	7711207 *K4* € 33,45

K3 - THE KIT IS ALSO AVAILABLE : FLY Clutch / CLUTCH Bell 5214111 € 63,00

K4 - THE KIT IS ALSO AVAILABLE : DELTA Clutch / WING Clutch Bell 5214110 € 93,84

with ENGINE →

PEUGEOT

PIAGGIO

JET FORCE
TSDILOOXOR
TSDINRG
MC3 PurejetNRG
Power Purejet

(HL 1)

50 2T LC

50 2T



50 2T LC

50 2T LC

DIGITRONIC K.R.M.

5512894

€ 210,11

This ECU (Electronic Control Unit) converts your fuel injected vehicle into a carburettored vehicle. In addition to the ECU, a carburettor and a specific cylinder and head, designed for a carburettor, are required. (see articles in the red frame -->)

	CYLINDER+HEAD	CAST-IRON Ø 40	3112898	31 8573	31 8523	31 8523
	(pin Ø 12)	ALUMINIUM Ø 40	€ 249,10	€ 124,91	€ 164,21	€ 164,21
	CYLINDER+HEAD		3112893	31 7133	31 7353	31 7353
	(pin Ø 12)	CAST-IRON Ø 47	€ 190,21	€ 123,02	€ 176,03	€ 176,03
	CYLINDER	CAST-IRON Ø 47	-	31 7132	-	-
	for ORIGINAL HEAD		€ 103,12			
	HEAD HTSR		-	38 7362	-	-
	for Malossi CYLINDER			€ 37,45		
	CYLINDER+HEAD MHR Replica		3112890	31 8640	31 8466	31 8466
	(pin Ø 12) ALUMINIUM	Ø 47-47,6	€ 303,85 Ø 47,6	€ 201,34 Ø 47	€ 239,46 Ø 47	€ 239,46 Ø 47
	CRANKSHAFT RHQ		5312781	-	53 7600	53 7600
	(carb.)	PIN Ø 12	€ 312,69		€ 175,50	€ 175,50
			5312781	-	5312331	5312331
	(inject.)	PIN Ø 12	€ 312,69		€ 301,56	€ 301,56
	GEARS HTQ		67 8378	-	67 9080 z 14/39 € 60,41	67 9080 z 14/39 € 60,41
	PRIMARY		€ 65,00 z 13/35		6713339 z 15/38 € 61,71	6713339 z 15/38 € 61,71
	ART OF PERFORMANCE / FLIP		-	-	3215167 € 175,70	3215167 € 175,70
	HOMOLOGATED	 Pg. 426			3216692 € 122,00	3216692 € 122,00
	REED VALVE		-	27 7440.C0	27 7708.C0	27 7708.C0
	CARBON FIBRE			€ 49,00 VL9	€ 48,95 VL11	€ 48,95 VL11
	CARBURETTOR	Ø 17,5	-	-	72 7084	72 7084
					€ 75,17	€ 75,17
	CARBURETTOR KIT	Ø 19	-	1611027	1611040	1611040
				€ 125,27	€ 118,04	€ 118,04
		Ø 21	1610995	-	1610997	1610997
			€ 114,23		€ 114,23	€ 114,23
		Ø 22	-	-	1611029	1611029
					€ 96,77	€ 96,77
	MULTIVAR		51 8752	51 8752	51 9019	51 9019
	VARIATOR		€ 58,71	€ 58,71	€ 61,80	€ 61,80
	X SPECIAL BELT		6112735	6112735	61 9831	61 9831
BELT		€ 15,46	€ 15,46	€ 19,49	€ 19,49	
X K BELT		6112736	6112736	6114118	6114118	
BELT		€ 27,23	€ 27,23	€ 38,25	€ 38,25	
	TORQUE DRIVER		-	61 8317	61 9100	61 9100
	MOBILE DRIVEN SPLIT PULLEY			€ 95,61	€ 85,57	€ 85,57
	FLY CLUTCH		52 8797 *K3*	52 8797 *K3*	52 8797 *K3*	52 8797 *K3*
	NOT ADJUSTABLE CLUTCH		€ 47,30	€ 47,30	€ 47,30	€ 47,30
DELTA CLUTCH		52 7880 *K4*	52 7880 *K4*	52 7880 *K4*	52 7880 *K4*	
ADJUSTABLE CLUTCH		€ 77,89	€ 77,89	€ 77,89	€ 77,89	
	CLUTCH BELL	Ø 107	7711115 *K3*	7711115 *K3*	7711115 *K3*	7711115 *K3*
	CLUTCH BELL (SMOOTH RING)		€ 22,60	€ 22,60	€ 22,60	€ 22,60
WING CLUTCH BELL	Ø 107	7711207 *K4*	7711207 *K4*	7711207 *K4*	7711207 *K4*	
CLUTCH BELL (FINNED RING)		€ 33,45	€ 33,45	€ 33,45	€ 33,45	

K3 - THE KIT IS ALSO AVAILABLE : FLY Clutch / CLUTCH Bell 5214111 € 63,00

K4 - THE KIT IS ALSO AVAILABLE : DELTA Clutch / WING Clutch Bell 5214110 € 93,84

APRILIA	GILERA	PIAGGIO
SR R FACTORY SR DITECH GP1	RUNNER PureJet	NRG MC3 Purejet NRG Power Purejet
(PIAGGIO C361M)		
50 2T LC	50 2T LC	50 2T LC

with ENGINE →

! TEAM Cylinder and crankshaft MUST BE INSTALLED AS A WHOLE

DIGITRONIC K.R.M. 5512894

€ 210,11

This ECU (Electronic Control Unit) converts your fuel injected vehicle into a carburettored vehicle. In addition to the ECU, a carburettor and a specific cylinder and head, designed for a carburettor, are required. (see articles in the red frame -->)

	CYLINDER+HEAD (pin 12)	Ø 40	31 8865	31 8865	31 8865
			€ 213,72	€ 213,72	€ 213,72
	CYLINDER+HEAD (pin 12)	Ø 47,6	31 8455	31 8455	31 8455
			€ 301,54	€ 301,54	€ 301,54
	CYLINDER+HEAD (pin 12)	Ø 47,6	3111584	3111584	3111584
		TEAM Replica	€ 324,71	€ 324,71	€ 324,71
	CRANKSHAFTS RHQ (carb.)	PIN Ø 12	53 7600	53 7600	53 7600
			€ 175,50	€ 175,50	€ 175,50
	CRANKSHAFTS RHQ (inject.)	PIN Ø 12	5312331	5312331	5312331
			€ 301,56	€ 301,56	€ 301,56
	CYLINDER+HEAD	Ø 40	31 8884	31 8884	31 8884
		TEAM	€ 284,08	€ 284,08	€ 284,08
	CRANKSHAFTS RHQ	PIN Ø 12	53 9212	53 9212	53 9212
			€ 285,15	€ 285,15	€ 285,15
	CRANKSHAFTS RHQ	PIN Ø 12	5316005	5316005	5316005
		TEAM	€ 478,00	€ 478,00	€ 478,00
	CYLINDER+HEAD	Ø 47,6	3115142	3115142	3115142
		TEAM 2	€ 376,00	€ 376,00	€ 376,00
	CRANKSHAFTS RHQ	PIN Ø 12	53 9212	53 9212	53 9212
			€ 285,15	€ 285,15	€ 285,15
	CRANKSHAFTS RHQ	PIN Ø 12	5316005	5316005	5316005
		TEAM	€ 478,00	€ 478,00	€ 478,00
	GEARS HTQ (PIAGGIO) PRIMARY	COUPLING Ø 17	67 9080 z 14/39 € 60,41	67 9080 z 14/39 € 60,41	67 9080 z 14/39 € 60,41
			6713339 z 15/38 € 61,71	6713339 z 15/38 € 61,71	6713339 z 15/38 € 61,71
	SCOOTER RACING	FOR CYLINDER Ø 47,6	-	32 9027	32 9027
				€ 314,23	€ 314,23
	SCOOTER RACING	FOR CYLINDER Ø 47,6	3215341	3215341	3215341
		TEAM 3	€ 366,18	€ 366,18	€ 366,18
	REED VALVE	CARBON FIBRE	27 9490.C0	27 9490.C0	27 9490.C0
			€ 52,25 VL13	€ 52,25 VL13	€ 52,25 VL13
	REED VALVE	CARBON FIBRE	2713719.C0	2713719.C0	2713719.C0
		TEAM	€ 57,68 VL16	€ 57,68 VL16	€ 57,68 VL16
	CARBURETTOR KIT	PHBG Ø 19	1611023	1611023	1611023
			€ 132,14	€ 132,14	€ 132,14
		PHBL Ø 25	1611009	1611009	1611009
			€ 217,99	€ 217,99	€ 217,99
		VHST Ø 28	1613766	1613766	1613766
		TEAM	€ 251,86	€ 251,86	€ 251,86
	MULTIVAR VARIATOR		5112645	5112645	5112645
			€ 77,25	€ 77,25	€ 77,25
	X KEVLAR BELT		6114118	6114118	6114118
	BELT		€ 38,25	€ 38,25	€ 38,25
	TORQUE DRIVER		61 9100	61 9100	61 9100
	MOBILE DRIVEN SPLIT PULLEY		€ 85,57	€ 85,57	€ 85,57
	KIT OVER RANGE / OVER RANGE ALUMINUM		6114219 € 262,65	6114219 € 262,65	6114219 € 262,65
			6115781 € 365,00	6115781 € 365,00	6115781 € 365,00
	1 MULTIVAR / ALUMINUM VARIATOR		5112645 € 77,25	5112645 € 77,25	5112645 € 77,25
			5115644 € 87,55	5115644 € 87,55	5115644 € 87,55
	2 X KEVLAR BELT		6114118	6114118	6114118
	BELT		€ 38,25	€ 38,25	€ 38,25
	3 REAR PULLEY SYSTEM		6113101	6113101	6113101
	REAR PULLEY		€ 174,40	€ 174,40	€ 174,40
	DELTA CLUTCH		52 7880	52 7880	52 7880
	ADJUSTABLE CLUTCH		€ 77,89	€ 77,89	€ 77,89
	WING CLUTCH BELL	Ø 107	7714147	7714147	7714147
	CLUTCH BELL (FINNED RING)		€ 90,00	€ 90,00	€ 90,00

19 - for the ASSEMBLY MODIFY the CRANKCASE

39 - WE SUGGEST TO USE BEARINGS : 6614105EA € 82,00

K6 - THE KIT IS ALSO AVAILABLE : DELTA Clutch / WING Clutch Bell 5214738 € 156,00



MALOSSI

Maxi Scooter 2T

with ENGINE 

APRILIA

GILERA

SR

SR

RUNNER FX

RUNNER FXR -
SP

125 2T



150 2T



125 2T

LC

180 2T

LC

	CYLINDER + HEAD Ø 65	31 8237	31 8237	3111140	3111140
	ALUMINIUM	€ 314,15	€ 314,15	€ 320,03	€ 320,03
	CYLINDER Ø 65	31 8236	31 8236	-	-
	ALUMINIUM	€ 278,10	€ 278,10		
	CRANKSHAFT RHQ	53 8906	53 8906	53 8906	53 8906
		€ 399,50	€ 399,50	€ 399,50	€ 399,50
	IGNITION CONTROLLER DIGITRONIC FOR VEHICLES WITHOUT IMMOBILIZER	-	-	5511399	5511399
				€ 142,68	€ 142,68
	MULTIVAR 2000 VARIATOR	5111258	5111258	5111258	5111258
		€ 115,36	€ 115,36	€ 115,36	€ 115,36
	X SPECIAL BELT BELT	6112737	6112737	6112737	6112737
	X K BELT BELT	€ 34,63	€ 34,63	€ 34,63	€ 34,63
	HTRoll ROLLERS FOR MULTIVAR 2000	6611095.00	6611095.00	6611095.00 *42*	6611095.00 *42*
		€ 13,64 gr.12,5	€ 13,64 gr.12,5	€ 13,64 gr.12,5	€ 13,64 gr.12,5
	HTRoll ROLLERS FOR ORIGINAL VARIATOR	66 9456.LO	66 9456.LO	66 9456.LO	6611095.UO
		€ 12,00 gr.12	€ 12,00 gr.12	€ 12,00 gr.12	€ 13,64 gr.15,5
	VENTILVAR 2000 FIXED HALF-PULLEY	-	-	-	-
	VARIABLE-SPEED DRIVE ADJUSTER SPRING  FOR VARIATOR	PG.445	PG.445	PG.445	PG.445
	TORSION CONTROLLER ANTIFRICTION FIFTH WHEEL	2513210	2513210	2513210	2513210
		€ 5,72	€ 5,72	€ 5,72	€ 5,72
	TORQUE DRIVER MOBILE DRIVEN SPLIT PULLEY	-	-	6111662	6111662
				€ 123,88	€ 123,88
	MAXI FLY CLUTCH NOT ADJUSTABLE CLUTCH	5212840	5212840	5212840	5212840
		€ 81,20	€ 81,20	€ 81,20	€ 81,20
	MAXI DELTA CLUTCH ADJUSTABLE CLUTCH	5211481	5211481	5211481	5211481
		€ 120,42	€ 120,42	€ 120,42	€ 120,42
	MAXI CLUTCH BELL CLUTCH BELL (SMOOTH RING)	-	-	-	-
	SPRINGS FOR MAXI FLY CLUTCH	2911326	2911326	2911326	2911326
		€ 17,00	€ 17,00	€ 17,00	€ 17,00
	SPRINGS FOR MAXI DELTA CLUTCH	2911326	2911326	2911326	2911326
	€ 17,00	€ 17,00	€ 17,00	€ 17,00	
SPRINGS FOR ORIGINAL CLUTCH	29 9644	29 9644	29 9644	29 9644	
	€ 18,00	€ 18,00	€ 18,00	€ 18,00	
	CARBURETTOR KIT SPORT	1611033	1611033	1611033 Ø 25 € 186,00	1611033 Ø 25 € 186,00
	CARBURETTOR KIT MHR	€ 186,00 Ø 25	€ 186,00 Ø 25	1611022 € 150,78 *78*	1611022 € 150,78 *78*
	REED VALVE SPORT CARBON FIBRE	27 7708.CO	27 7708.CO	27 7708.CO	27 7708.CO
		€ 48,95 VL11	€ 48,95 VL11	€ 48,95 VL11	€ 48,95 VL11
	REED VALVE MHR / MHR TEAM	27 9490.CO *43*	27 9490.CO *43*	27 9490.CO *43*	27 9490.CO *43*
	€ 52,25 VL13	€ 52,25 VL13	€ 52,25 VL13	€ 52,25 VL13	
PETALS SET FOR REED VALVE	27 7054.CO	27 7054.CO	27 7054.CO	27 7054.CO	
	€ 18,71	€ 18,71	€ 18,71	€ 18,71	

Products to be used exclusively for racing in places specially designed for such activity according to the regulations of the competent sporting authorities. We accept no liability resulting from improper use.

41 - For vehicles WITH HONDA ORIGINAL half-pulley "marked" : "GF" 66 9917.B0 gr.13 - "FG" 66 9917.E0 € 19,12

42 - ONLY FOR vehicles WITH EXHAUST SY. MHR 32 9612 : 6611095.F0 gr.09 € 13,64

43 - VL16 MHR TEAM, for the ASSEMBLY MODIFY the CRANKCASE: 2713719.CO € 57,68

70 - For vehicles WITH ORIGINAL half-pulley "marked": "GF" 2911072.W0 - "FG" 2911074.Y0 € 10,71

GILERA		HONDA		ITALJET		PIAGGIO	
TYPHOON	TYPHOON X	PANTHEON	PANTHEON	DRAGSTER	DRAGSTER	HEXAGON	HEXAGON LX
125 2T	125 2T	125 2T	150 2T	125 2T	180 2T	125 2T	125 2T
		LC	LC	LC	LC	LC	LC
31 8237 € 314,15	31 8237 € 314,15	-	-	3111140 € 320,03	3111140 € 320,03	3111140 € 320,03	3111140 € 320,03
31 8236 € 278,10	31 8236 € 278,10	-	-	-	-	-	-
53 8906 € 399,50	53 8906 € 399,50	-	-	53 8906 € 399,50	53 8906 € 399,50	53 8906 € 399,50	53 8906 € 399,50
-	-	-	-	5511399 € 142,68	5511399 € 142,68	5511399 € 142,68	5511399 € 142,68
5111258 € 115,36	5111258 € 115,36	5111261 € 127,92	5111261 € 127,92	5111258 € 115,36	5111258 € 115,36	5111258 € 115,36	5111258 € 115,36
6112737 € 34,63	6112737 € 34,63	6114127 € 24,42 6112788 € 48,57	6114127 € 24,42 6112788 € 48,57	6112737 € 34,63	6112737 € 34,63	6112737 € 34,63	6112737 € 34,63
6611095.OO € 13,64 gr.12,5	6611095.OO € 13,64 gr.12,5	*41*	*41*	6611095.OO *42* € 13,64 gr.12,5	6611095.OO *42* € 13,64 gr.12,5	6611095.OO € 13,64 gr.12,5	6611095.OO € 13,64 gr.12,5
66 9456.LO € 12,00 gr.12	66 9456.LO € 12,00 gr.12	-	66 9917.I0 € 19,12	66 9456.LO € 12,00 gr.12	6611095.U0 € 13,64 gr.15,5	66 9456.LO € 12,00 gr.12	66 9456.LO € 12,00 gr.12
-	-	6111347B € 36,72	6111347B € 36,72	-	-	-	-
PG.445	PG.445	*70*	*70*	PG.445	PG.445	PG.445	PG.445
2513210 € 5,72	2513210 € 5,72	-	-	2513210 € 5,72	2513210 € 5,72	2513210 € 5,72	2513210 € 5,72
-	6111662 € 123,88	6111964 € 177,16	6111964 € 177,16	6111662 € 123,88	6111662 € 123,88	6111662 € 123,88	6111662 € 123,88
5212840 € 81,20	5212840 € 81,20	-	-	5212840 € 81,20	5212840 € 81,20	5212840 € 81,20	5212840 € 81,20
5211481 € 120,42	5211481 € 120,42	5211553 € 120,42	5211553 € 120,42	5211481 € 120,42	5211481 € 120,42	5211481 € 120,42	5211481 € 120,42
-	-	7714326 € 77,00 Ø 135	7714326 € 77,00 Ø 135	-	-	-	-
2911326 € 17,00	2911326 € 17,00	-	-	2911326 € 17,00	2911326 € 17,00	2911326 € 17,00	2911326 € 17,00
2911326 € 17,00	2911326 € 17,00	2911326 € 17,00	2911326 € 17,00	2911326 € 17,00	2911326 € 17,00	2911326 € 17,00	2911326 € 17,00
29 9644 € 18,00	29 9644 € 18,00	2911326 € 17,00	2911326 € 17,00	29 9644 € 18,00	29 9644 € 18,00	29 9644 € 18,00	29 9644 € 18,00
1611033 € 186,00 Ø 25	1611033 € 186,00 Ø 25	-	-	1611033 Ø 25 € 186,00 1611022 € 150,78 *78*	1611033 Ø 25 € 186,00 1611022 € 150,78 *78*	1611034 € 168,66 Ø 25	1611034 € 168,66 Ø 25
27 7708.C0 € 48,95 VL11	27 7708.C0 € 48,95 VL11	-	-	27 7708.C0 € 48,95 VL11	27 7708.C0 € 48,95 VL11	27 7708.C0 € 48,95 VL11	27 7708.C0 € 48,95 VL11
27 9490.C0 *43* € 52,25 VL13	27 9490.C0 *43* € 52,25 VL13	-	-	27 9490.C0 *43* € 52,25 VL13	27 9490.C0 *43* € 52,25 VL13	27 9490.C0 *43* € 52,25 VL13	27 9490.C0 *43* € 52,25 VL13
27 7054.C0 € 18,71	27 7054.C0 € 18,71	-	-	27 7054.C0 € 18,71	27 7054.C0 € 18,71	27 7054.C0 € 18,71	27 7054.C0 € 18,71

78 - ALSO AVAILABLE : MHR TEAM Ø 28, 1613766 € 251,86



MALOSSİ

Maxi Scooter 2T

with ENGINE 

APRILIA

GILERA

SR

SR

RUNNER FX

RUNNER FXR -
SP

125 2T



150 2T











125 2T

LC

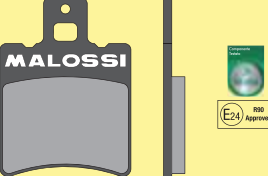
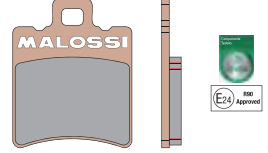
180 2T

LC

	SCOOTER RACING MHR EXHAUST SYSTEM		-	-	32 9612 € 345,00	32 9612 € 345,00
	RED SPONGE FOR ORIGINAL AIR BOX		-	-	1411424 € 4,57	1411424 € 4,57
	DOUBLE RED SPONGE FOR ORIGINAL AIR BOX		-	-	1414504 € 7,73	1414504 € 7,73
	GEARS HTQ SECONDARY (Ø COUPLING)		6711079 € 71,36 z 15/41 (17)	6711079 € 71,36 z 15/41 (17)	PG.478	67 9925 *PG* € 71,36 z 14/43 (17)
	BRAKE PADS FRONT ORGANIC BRAKE PADS		-	-	-	-
	BRAKE PADS MHR FRONT ORGANIC BRAKE PADS		-	-	-	-
	BRAKE PADS MHR SYNT FRONT SINTERED BRAKE PADS		6211649 € 15,00 1999->	6211649 € 15,00 1999->	6215011 € 16,00 2000->	6215011 € 16,00 1999->
	BRAKE PADS REAR ORGANIC BRAKE PADS		-	-	6215049 € 6,24 2000->	6215049 € 6,24 1999->
	BRAKE PADS MHR REAR ORGANIC BRAKE PADS		-	-	6215074 € 6,30 2000->	6215074 € 6,30 1999->
	BRAKE PADS MHR SYNT REAR SINTERED BRAKE PADS		-	-	6215006 € 11,96 2000->	6215006 € 11,96 1999->
	BRAKE POWER REAR BRAKE SHOES		-	-	-	-
	WHOOPIE DISC FRONT BRAKE DISC		-	-	6212929 € 105,00 2000->	6212929 € 105,00 1999->
	RS24 REAR SHOCK ABSORBER		-	-	46 8308 € 248,50	46 8308 € 248,50
	RS24 FRONT SHOCK ABSORBER		-	-	-	-
	RS24 FRONT + REAR		-	-	-	-
	RS24/10-R REAR SHOCK ABSORBER		-	-	4614237 € 428,82	4614237 € 428,82
	HORQUILLA F32S FORK STEMS Ø 32		-	-	46 9627 € 688,26	46 9627 € 688,26
	HORQUILLA F37R FORK STEMS Ø 37		-	-	4616135 € 1122,00	4616135 € 1122,00

Products to be used exclusively for racing in places specially designed for such activity according to the regulations of the competent sporting authorities. We accept no liability resulting from improper use.

PG - SPECIFICATIONS on the PAGE indicated in the TITLE of the LINE

GILERA		HONDA		ITALJET		PIAGGIO	
TYPHOON	TYPHOON X	PANTHEON	PANTHEON	DRAGSTER	DRAGSTER	HEXAGON	HEXAGON LX
125 2T	125 2T	125 2T	150 2T	125 2T	180 2T	125 2T	125 2T
		LC	LC	LC	LC	LC	LC
-	-	-	-	32 9612 €345,00	32 9612 €345,00	-	-
-	-	-	-	1411424 €4,57	1411424 €4,57	-	-
-	-	-	-	1414504 €7,73	1414504 €7,73	-	-
67 8657 *PG* €64,92 z 15/41 (17)	6711079 *PG* €71,36 z 15/41 (17)	6711060 €97,69 z 17/41	6711060 €97,69 z 17/41	PG.478	67 9925 €71,36 z 14/43 (17)	67 8657 *PG* €64,92 z 15/41 (17)	PG.478
6215042 €5,72 1995->	6215042 €5,72 1995->	-	-	6215051 €5,72 1999->	6215051 €5,72 1999->	6215042 €5,72 1994->	-
6215080 €6,00 1995->	6215080 €6,00 1995->	-	-	6215076 €6,24 1999->	6215076 €6,24 1999->	6215080 €6,00 1994->	-
6215007 €11,96 1995->	6215007 €11,96 1995->	6215032 €20,00 1998->	6215032 €20,00 1998->	6215005 €11,96 1999->	6215005 €11,96 1999->	6215007 €11,96 1994->	6215011 €16,00 1998->
-	-	-	-	-	-	-	-
-	-	-	-	-	-	-	-
-	-	-	-	-	-	-	-
6215328 €18,39 1995->	6215328 €18,39 1995->	-	-	-	-	6215328 €18,39 1994->	-
6212603 €72,56 1995->	6212603 €72,56 1995->	6212342 €87,50 1998->	6212342 €87,50 1998->	-	-	-	6212604 €76,38 62 9078 MHR 1998-> €79,00
46 8308 €248,50	46 8308 €248,50	-	-	-	-	46 8607 €141,36	46 8607 €141,36
-	-	-	-	-	-	-	-
-	-	-	-	-	-	-	-
-	-	-	-	-	-	-	-
46 9550 €591,80	46 9550 €591,80	-	-	-	-	-	-
-	-	-	-	-	-	-	-



MALOSSI

Maxi Scooter 2T

with ENGINE 

PIAGGIO

HEXAGON

HEXAGON LXT

SKIPPER

SKIPPER LX

150 2T

LC

180 2T

LC

125 2T



125 2T



	CYLINDER + HEAD Ø 65	3111140	3111140	31 8237	31 8237
	ALUMINIUM	€ 320,03	€ 320,03	€ 314,15	€ 314,15
	CYLINDER Ø 65	-	-	31 8236	31 8236
	ALUMINIUM	-	-	€ 278,10	€ 278,10
	CRANKSHAFT RHQ	53 8906	53 8906	53 8906	53 8906
		€ 399,50	€ 399,50	€ 399,50	€ 399,50
	IGNITION CONTROLLER DIGITRONIC FOR VEHICLES WITHOUT IMMOBILIZER	5511399	5511399	-	-
		€ 142,68	€ 142,68		
	MULTIVAR 2000 VARIATOR	5111258	5111258	5111258	5111258
		€ 115,36	€ 115,36	€ 115,36	€ 115,36
	X SPECIAL BELT BELT	6112737	6112737	6112737	6112737
	X K BELT BELT	€ 34,63	€ 34,63	€ 34,63	€ 34,63
	HTRoll ROLLERS FOR MULTIVAR 2000	6611095.00	6611095.00	6611095.00	6611095.00
		€ 13,64 gr.12,5	€ 13,64 gr.12,5	€ 13,64 gr.12,5	€ 13,64 gr.12,5
	HTRoll ROLLERS FOR ORIGINAL VARIATOR	66 9456.LO	6611095.U0	66 9456.LO	66 9456.LO
		€ 12,00 gr.12	€ 13,64 gr.15,5	€ 12,00 gr.12	€ 12,00 gr.12
	VENTILVAR 2000 FIXED HALF-PULLEY	-	-	-	-
	VARIABLE-SPEED DRIVE ADJUSTER SPRING  FOR VARIATOR	PG.445	PG.445	PG.445	PG.445
	TORSION CONTROLLER ANTIFRICTION FIFTH WHEEL	2513210	2513210	2513210	2513210
		€ 5,72	€ 5,72	€ 5,72	€ 5,72
	TORQUE DRIVER MOBILE DRIVEN SPLIT PULLEY	6111662	6111662	-	-
		€ 123,88	€ 123,88		
	MAXI FLY CLUTCH NOT ADJUSTABLE CLUTCH	5212840	5212840	5212840	5212840
		€ 81,20	€ 81,20	€ 81,20	€ 81,20
	MAXI DELTA CLUTCH ADJUSTABLE CLUTCH	5211481	5211481	5211481	5211481
		€ 120,42	€ 120,42	€ 120,42	€ 120,42
	MAXI CLUTCH BELL CLUTCH BELL (SMOOTH RING)	-	-	-	-
	SPRINGS FOR MAXI FLY CLUTCH	2911326	2911326	2911326	2911326
		€ 17,00	€ 17,00	€ 17,00	€ 17,00
	SPRINGS FOR MAXI DELTA CLUTCH	2911326	2911326	2911326	2911326
	€ 17,00	€ 17,00	€ 17,00	€ 17,00	
SPRINGS FOR ORIGINAL CLUTCH	29 9644	29 9644	29 9644	29 9644	
	€ 18,00	€ 18,00	€ 18,00	€ 18,00	
	CARBURETTOR KIT SPORT	1611034	1611034	1611033	1611033
	CARBURETTOR KIT MHR	€ 168,66 Ø 25	€ 168,66 Ø 25	€ 186,00 Ø 25	€ 186,00 Ø 25
	REED VALVE SPORT CARBON FIBRE	27 7708.C0	27 7708.C0	27 7708.C0	27 7708.C0
		€ 48,95 VL11	€ 48,95 VL11	€ 48,95 VL11	€ 48,95 VL11
	REED VALVE MHR / MHR TEAM	27 9490.C0 *43*	27 9490.C0 *43*	27 9490.C0 *43*	27 9490.C0 *43*
	€ 52,25 VL13	€ 52,25 VL13	€ 52,25 VL13	€ 52,25 VL13	
PETALS SET FOR REED VALVE	27 7054.C0	27 7054.C0	27 7054.C0	27 7054.C0	
	€ 18,71	€ 18,71	€ 18,71	€ 18,71	

43 - VL16 MHR TEAM, for the ASSEMBLY MODIFY the CRANKCASE: 2713719.C0 € 57,68

PIAGGIO							
SKIPPER	SKIPPER LXT						

150 2T  150 2T 

31 8237 € 314,15	31 8237 € 314,15	-	-	-	-	-	-
31 8236 € 278,10	31 8236 € 278,10	-	-	-	-	-	-
53 8906 € 399,50	53 8906 € 399,50	-	-	-	-	-	-
-	-	-	-	-	-	-	-
5111258 € 115,36	5111258 € 115,36	-	-	-	-	-	-
6112737 € 34,63	6112737 € 34,63	-	-	-	-	-	-
6611095.00 € 13,64 gr.12,5	6611095.00 € 13,64 gr.12,5	-	-	-	-	-	-
66 9456.L0 € 12,00 gr.12	66 9456.L0 € 12,00 gr.12	-	-	-	-	-	-
-	-	-	-	-	-	-	-
PG.445	PG.445	-	-	-	-	-	-
2513210 € 5,72	2513210 € 5,72	-	-	-	-	-	-
-	-	-	-	-	-	-	-
5212840 € 81,20	5212840 € 81,20	-	-	-	-	-	-
5211481 € 120,42	5211481 € 120,42	-	-	-	-	-	-
-	-	-	-	-	-	-	-
2911326 € 17,00	2911326 € 17,00	-	-	-	-	-	-
2911326 € 17,00	2911326 € 17,00	-	-	-	-	-	-
29 9644 € 18,00	29 9644 € 18,00	-	-	-	-	-	-
1611033 € 186,00 Ø 25	1611033 € 186,00 Ø 25	-	-	-	-	-	-
27 7708.C0 € 48,95 VL11	27 7708.C0 € 48,95 VL11	-	-	-	-	-	-
27 9490.C0 *43* € 52,25 VL13	27 9490.C0 *43* € 52,25 VL13	-	-	-	-	-	-
27 7054.C0 € 18,71	27 7054.C0 € 18,71	-	-	-	-	-	-



MALOSI

Maxi Scooter 2T

with ENGINE 

PIAGGIO

HEXAGON

HEXAGON LXT

SKIPPER

SKIPPER LX

150 2T

LC

180 2T







LC

125 2T

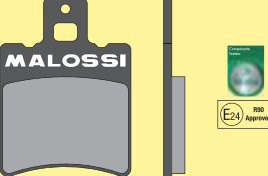

125 2T



	SCOOTER RACING MHR EXHAUST SYSTEM		-	-	-	-
	RED SPONGE FOR ORIGINAL AIR BOX		-	-	-	1411424 € 4,57
	DOUBLE RED SPONGE FOR ORIGINAL AIR BOX		-	-	-	1414504 € 7,73
	GEARS HTQ SECONDARY (Ø COUPLING)		67 8657 *PG* € 64,92 z 15/41 (17)	67 9925 *PG* € 71,36 z 14/43 (17)	-	PG.478
	BRAKE PADS ORGANIC BRAKE PADS	FRONT	6215042 € 5,72 1994->	-	6215047 € 6,76 1993->	-
	BRAKE PADS MHR ORGANIC BRAKE PADS	FRONT	6215080 € 6,00 1994->	-	62 9088 € 6,55 1993->	-
	BRAKE PADS MHR SYNT SINTERED BRAKE PADS	FRONT	6215007 € 11,96 1994->	6215011 € 16,00 1998->	-	-
	BRAKE PADS ORGANIC BRAKE PADS	REAR	-	-	-	-
	BRAKE PADS MHR ORGANIC BRAKE PADS	REAR	-	-	-	-
	BRAKE PADS MHR SYNT SINTERED BRAKE PADS	REAR	-	-	-	-
	BRAKE POWER BRAKE SHOES	REAR	6215328 € 18,39 1994->	-	6215328 € 18,39 1993->	-
	WHOOOP DISC FRONT BRAKE DISC		-	6212604 € 76,38 62 9078 MHR 1998-> € 79,00	-	-
	RS24 REAR SHOCK ABSORBER		46 8607 € 141,36	46 8607 € 141,36	46 8308 € 248,50	46 8308 € 248,50
	RS24 FRONT SHOCK ABSORBER		-	-	46 7900 € 222,63	-
	RS24 FRONT + REAR		-	-	46 9031 € 456,47	-
	RS24/10-R REAR SHOCK ABSORBER		-	-	-	-
	HORQUILLA F32S FORK STEMS Ø 32		-	-	-	-
	HORQUILLA F37R FORK STEMS Ø 37		-	-	-	-

PG - SPECIFICATIONS on the PAGE indicated in the TITLE of the LINE

PIAGGIO							
SKIPPER	SKIPPER LXT						

150 2T  150 2T 

-	-	-	-	-	-	-	-
-	1411424 € 4,57	-	-	-	-	-	-
-	1414504 € 7,73	-	-	-	-	-	-
-	PG.478	-	-	-	-	-	-
6215047 € 6,76 1993->	-	-	-	-	-	-	-
62 9088 € 6,55 1993->	-	-	-	-	-	-	-
-	-	-	-	-	-	-	-
-	-	-	-	-	-	-	-
-	-	-	-	-	-	-	-
-	-	-	-	-	-	-	-
6215328 € 18,39 1993->	-	-	-	-	-	-	-
-	-	-	-	-	-	-	-
46 8308 € 248,50	46 8308 € 248,50	-	-	-	-	-	-
46 7900 € 222,63	-	-	-	-	-	-	-
46 9031 € 456,47	-	-	-	-	-	-	-
-	-	-	-	-	-	-	-
-	-	-	-	-	-	-	-
-	-	-	-	-	-	-	-



5715845**€ 470,00****New****Technical features :**

- Crankcase pair, die-cast material in aluminum silicon alloy with high mechanical resistance.
- Crankcases inclusive of silent block 5,250 Kg.
- Crankshaft - clutch shaft wheelbase 270 mm.
- Crankshaft bearings 20 x 47 x 14.
- Oil seals FKM plus PTFE.
- Reed valve VL 18.
- Intake manifold X360 Ø 21 - 28 length 27.
- Cylinder stud bolts material: steel 8.8 UNI EN20898/1.
- Oversized cooling fluid connector: external Ø 18 mm - internal Ø 13,5 mm.
- Wheel axle bearing 20 x 47 x 14.
- Roller gear cover size 16 x 22 x 12.

Cylinder kit Flanged Mount**Testa rossa Ø 52****3115883 € 437,00****MALOSSI RC-one****New****CRANKSHAFT RHQ pin Ø 12 - 13****MHR TEAM****5316029 € 465,00**

- Half-shafts material: 18 Ni Cr Mo5.
- Half-shafts with forged monolithic rotating masse.
- Manufactured using high-precision machine tools.
- All components are subjected to 5 heating treatment operations.
- Excellent surface finish for improved reliability.
- Dynamic balancing for speeds of up to 16,000 rpm.
- Coppered connecting rod in forged 18 Ni Cr Mo5, connected to the engine with precision roller bearing for high speeds.

**EXHAUST SYSTEM
SCOOTER RACING
MHR BIG BORE Ø 52****3216158 € 366,18****BRAKE POWER****rear brake shoes****6215328 - 1996-> € 18,39**

Made of a special aluminium-magnesium alloy and a special asbestos-free friction material, in compliance with new EEC regulations.

**RS24/10-R shock absorber pair****front / rear****4614479 € 814,98**

- Oil-gas suspension with variable setting and extension/compression adjusting, compensated for a pressurized nitrogen chamber.
- Extension adjustment in order to absorb the harshness of the ground;
- Double adjusting of hydraulic system in compression (separated according low and high speed);
- Spring pre-load allows to fit the vehicle while driving;
- System of setting variation as regards the behavior in bends.

**PRIMARY GEARS HTQ z 16/37****6711449 - 2001-> € 60,41****SECONDARY GEARS****HTQ z 14/47****(forced Ø 17)****67 9968 € 61,65****Zip S**

Note: suggested setting example, please check in the following brand/model tables the items suitable for your vehicle.

MHR TEAM INNER ROTOR IGNITION

5515001 € 350,00

- Variable advance
- Microprocessor control.
- S.M.T. assembly technology.
- Constant 30,000 V discharge voltage up to 20,000 rpm.
- Available spare parts controller DIGITRONIC-TRIMMER



OVER RANGE MHR ALUMINUM - PIAGGIO 2000

6115781 - 2001-> € 365,00

Kit Over Range MHR Aluminum Malossi - High Performance Scooter Transmission



DELTA CLUTCH

52 7880 € 77,89

Automatic clutch with variable adjustments



FUEL TAP

6511990B € 21,35

Fully aluminum RACING tap with violet anodized screw opening/closing knob. Ø 15 mm inserting to tank with blocking clamp. Ø 9 mm inserting petrol pipe



WING CLUTCH BELL Ø 107

7714147 € 90,00

Forged clutch bell, without welds, made of 39NiCrMo5 steel, nitrogen surface hardened with an antioxidant surface treatment. Machined finned reinforcement corona enhances heat dissipation, protecting the clutch's friction material, tested to over 20,000 RPM.



MHR RADIATOR

7115431 - 2001--> € 626,00

7115430 - <-2000 € 634,00

Malossi MHR Team radiators are made with radiant packs having an increased surface, capable of ensuring a high-efficiency thermal exchange by maintaining a cooling liquid temperature within an optimal range, even in the most heavy-duty conditions.



ENERGY PUMP

Water pump

5616363

€ 123,00

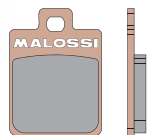

BRAKE PADS MHR SYNT

6215006 € 11,96

front homologated 1996->

BRAKE POWER DISC MHR

front 1996->

62 9078 € 79,00

Malossi has designed and developed this brake disc for the latest generation of scooters. This brake disc represents the highest technology in the industry: cut with a laser to respect the strict tolerances imposed; the friction surfaces must respect very strict parallel and roughness tolerances; the ventilation holes have been developed to ensure constant performance even under extreme conditions.



MHR BRAKE FRONT HOSE (AERONAUTICAL) 1,11mt

22 9548 € 55,43

Brake front hose



RC ONE YAMAHA
5716668 € 498,00



- Technical features:**
- Crankcase pair, die-cast material in aluminum silicon alloy with high mechanical resistance.
 - Crankcases inclusive of bearings 5.150 Kg.
 - Crankshaft - clutch shaft wheelbase 270 mm.
 - Crankshaft bearings 20 x 47 x 14.
 - Oil seals FKM plus PTFE.
 - Reed valve VL 18.
 - Intake manifold X360 Ø 21 - 28 length 27.
 - Oversized cooling fluid connector: external Ø 18 mm - internal Ø 13,5 mm.
 - Wheel axle bearing 20 x 47 x 14.
 - Pinwheel.
 - Roller gear cover size 16 x 22 x 12.

New

Cylinder kit Flanged Mount
Testa rossa Ø 52
3115883 € 437,00
MALOSSI RC-one



New

CRANKSHAFT RHQ pin Ø 12 - 13
MHR TEAM

5316029 € 465,00

- Half-shafts material: 18 Ni Cr Mo5.
- Half-shafts with forged monolithic rotating masse.
- Manufactured using high-precision machine tools.
- All components are subjected to 5 heating treatment operations.
- Excellent surface finish for improved reliability.
- Dynamic balancing for speeds of up to 16,000 rpm.
- Coppered connecting rod in forged 18 Ni Cr Mo5, connected to the engine with precision roller bearing for high speeds.

EXHAUST SYSTEM
SCOOTER RACING
MHR BIG BORE Ø 52
3216158 € 366,18



REAR SHOCK ABSORBER
RS24/10

4613081 € 524,44

- Oil-pneumatic shock absorber
- Micrometric regulation of spring preloading by means of ring nuts
- 24-position adjustment of hydraulic braking in expansion
- 10-positions adjustment of hydraulic braking in compression
- Special low-viscosity oil, practically unaffected by temperature changes



PRIMARY GEARS HTQ z 16/37
6711449 € 60,41



SECONDARY GEARS
HTQ z 14/47
(forced Ø 17)
67 9968 € 61,65



Note: suggested setting example, please check in the following brand/model tables the items suitable for your vehicle.

MHR TEAM INNER ROTOR IGNITION**5515001 € 350,00**

- Variable advance
- Microprocessor control.
- S.M.T. assembly technology.
- Constant 30,000 V discharge voltage up to 20,000 rpm.
- Available spare parts controller DIGITRONIC-TRIMMER

**OVER RANGE MHR ALUMINUM - PIAGGIO 2000****6115781 - 2001-> € 365,00**

Kit Over Range MHR Aluminum Malossi - High Performance Scooter Transmission

**DELTA CLUTCH****52 7880 € 77,89**

Automatic clutch with variable adjustments

**FUEL TAP****6511990B € 21,35**

Fully aluminum RACING tap with violet anodized screw opening/closing knob. Ø 15 mm inserting to tank with blocking clamp. Ø 9 mm inserting petrol pipe

**WING CLUTCH BELL Ø 107****7714147 € 90,00**

Forged clutch bell, without welds, made of 39NiCrMo5 steel, nitrogen surface hardened with an antioxidant surface treatment. Machined finned reinforcement corona enhances heat dissipation, protecting the clutch's friction material, tested to over 20,000 RPM.

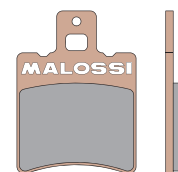
**BRAKE PADS MHR SYNT front homologated****6215008 € 11,96****KIT WHOOP DISC Ø 250 front "OVERSIZED"****6213297 € 189,95****ENERGY PUMP****Water pump****5616363****€ 123,00****OX 50**

5715845

€ 470,00

New

**Technical features :**

- Crankcase pair, die-cast material in aluminum silicon alloy with high mechanical resistance.
- Crankcases inclusive of silent block 5,250 Kg.
- Crankshaft - clutch shaft wheelbase 270 mm.
- Crankshaft bearings 20 x 47 x 14.
- Oil seals FKM plus PTFE.
- Reed valve VL 18.
- Intake manifold X360 Ø 21 - 28 length 27.
- Cylinder stud bolts material: steel 8.8 UNI EN20898/1.
- Oversized cooling fluid connector: external Ø 18 mm - internal Ø 13,5 mm.
- Wheel axle bearing 20 x 47 x 14.
- Roller gear cover size 16 x 22 x 12.

Cylinder kit Flanged Mount

Testa rossa Ø 52

3115883 € 437,00

MALOSSI RC-one

New

**CRANKSHAFT RHQ pin Ø 12 - 13**

MHR TEAM

5316029 € 465,00

- Half-shafts material: 18 Ni Cr Mo5.
- Half-shafts with forged monolithic rotating masse.
- Manufactured using high-precision machine tools.
- All components are subjected to 5 heating treatment operations.
- Excellent surface finish for improved reliability.
- Dynamic balancing for speeds of up to 16,000 rpm.
- Coppered connecting rod in forged 18 Ni Cr Mo5, connected to the engine with precision roller bearing for high speeds.

**EXHAUST SYSTEM
SCOOTER RACING
MHR BIG BORE Ø 52**

3216158 € 366,18

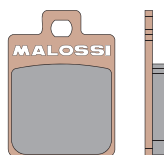

Runno

**BRAKE PADS MHR SYNT
rear homologated**

6215006 € 11,96

**Rear shock absorber
RS24/10-R**

4614237 € 428,82

**ENERGY PUMP**

5616363

€ 123,00

**PRIMARY GEARS HTQ z 16/37**

6711449 - 2001-> € 60,41

**SECONDARY GEARS**

HTQ z 14/47

(forced Ø 17)

67 9968 € 61,65



MHR TEAM INNER ROTOR IGNITION

5515001 € 350,00

- Variable advance
- Microprocessor control.
- S.M.T. assembly technology.
- Constant 30,000 V discharge voltage up to 20,000 rpm.
- Available spare parts controller DIGITRONIC-TRIMMER



OVER RANGE MHR ALUMINUM - PIAGGIO 2000

6115781 - 2001-> € 365,00

Kit Over Range MHR Aluminum Malossi - High Performance Scooter Transmission



DELTA CLUTCH

52 7880 € 77,89

Automatic clutch with variable adjustments



FUEL TAP

6511990B € 21,35

Fully aluminum RACING tap with violet anodized screw opening/closing knob. Ø 15 mm inserting to tank with blocking clamp. Ø 9 mm inserting petrol pipe



WING CLUTCH BELL Ø 107

7714147 € 90,00

Forged clutch bell, without welds, made of 39NiCrMo5 steel, nitrogen surface hardened with an antioxidant surface treatment. Machined finned reinforcement corona enhances heat dissipation, protecting the clutch's friction material, tested to over 20,000 RPM.

RADIATOR MHR <-2005

71 9786 € 214,59



BRAKE PADS MHR SYNT front homologated

6215013 - 1997-> € 16,50

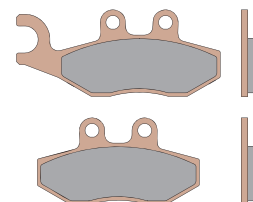

FORK KIT

F32S <-2005

46 9552 € 563,41

F32S 2006->

4613086 € 649,03

F37R 2006->

4616136 € 1.122,00



er SP



Scooter 50

with ENGINE

APRILIA

AREA 51

RALLY

RALLY

SCARABEO
STREET

(MINARELLI)

(MINARELLI)

(PIAGGIO)

50 2T

LC

50 2T

50 2T

LC

50 2T

TEAM Cylinder and crankshaft MUST BE INSTALLED AS A WHOLE

	CYLINDER+HEAD	Ø 40 (pin)	31 8559 1 €209,16 (10)	31 8403 1 €184,06 (10)	31 8559 1 €209,16 (10)	31 8862 €174,92 (12)
	CYLINDER+HEAD	Ø 47-47,6 (pin)	31 8460 €301,54 Ø 47,6 (12)	31 8440 €267,15 Ø 47,6 (12)	31 8460 €301,54 Ø 47,6 (12)	31 8398 €267,15 Ø 47,6 (12)
	CYLINDER+HEAD	Ø 47,6 (pin)	-	-	-	-
	CRANKSHAFTS RHQ	PIN Ø 12	53 8009 €175,50	53 8009 €175,50	53 8009 €175,50	53 7600 €175,50
	CYLINDER+HEAD	Ø 40	3111511 €302,14	-	-	31 8881 *38* €181,70
	CYLINDER+HEAD	Ø 47,6	3112642 €357,72	-	*75*	-
	TEAM - TEAM 2	STROKE 39 mm C.ROD 80 - 85	-	-	-	-
	CYLINDER+HEAD	Ø 50	-	-	-	-
	BIG BORE	STROKE 39 mm C.ROD 85	-	-	-	-
	CRANKSHAFTS RHQ	PIN Ø 12	53 8855 €177,14 53 8009 €175,50	-	*75*	53 9212 €285,15
	CRANKSHAFTS RHQ	PIN Ø 12 - 13	5315973 €480,00	-	*75*	5316005 *39* €478,00
	TEAM	STROKE 39 mm C.ROD 85 - 80	5314548 €465,00	-	-	-
	CYLINDER+HEAD	Ø 50	-	-	-	-
	BIG BORE	STROKE 44 mm C.ROD 85	-	-	-	-
	CRANKSHAFTS RHQ	PIN Ø 13	5313275 *79* €450,00	-	-	-
	BIG BORE	STROKE 44 mm C.ROD 85	-	-	-	-
	CYLINDER+HEAD	Ø 52	3115374 €430,00	-	-	-
	BIG BORE testa rossa	STROKE 44 mm C.ROD 90	-	-	-	-
	CRANKSHAFTS RHQ	PIN Ø 13	5316039 *79* €465,00	-	-	-
	TEAM	STROKE 44 mm C.ROD 90	-	-	-	-
	RADIAL ROLLER BEARING	PG. 473	PG.473	PG.473	PG.473	6614105EA €82,00
	EXHAUST SYSTEM SCOOTER RACING	Ø 40	3212825 €308,06 DISMANTLED	-	-	-
	EXHAUST SYSTEM SCOOTER RACING	Ø 47 - 47,6	-	32 7562 €266,00	32 7562 €266,00	32 9834 €377,08
	EXHAUST SYSTEM SCOOTER RACING	Ø 47,6	-	3214763 €366,18	3214763 €366,18	-
	EXHAUST SYSTEM SCOOTER RACING	Ø 47,6	-	-	-	-
	EXHAUST SYSTEM SCOOTER RACING	Ø 47,6	-	-	-	-
	EXHAUST SYSTEM SCOOTER RACING	Ø 50	3215198 €366,18	-	-	-
	BIG BORE 2 Ø 50	STROKE 39 - 44 mm	-	-	-	-
	EXHAUST SYSTEM SCOOTER RACING	Ø 52	3216827 €366,18	-	-	-
	BIG BORE Ø 52	STROKE 44 mm	-	-	-	-
	CARBURETTOR KIT	PHBG Ø 19	1611021 €129,40	1611021 €129,40	1611021 €129,40	1611021 €129,40
		PHBG Ø 19	1611021.T €202,60	1611021.T €202,60	1611021.T €202,60	1611021.T €202,60
		PHBG Ø 21	1613890.TO €210,60	1613890.TO €210,60	1613890.TO €210,60	1613890.TO €210,60
		PHBL Ø 25	1611013 €217,38	-	1611013 €217,38	-
		VHST Ø 28	1614022 €251,86	1614022 €251,86	1614022 €251,86	1613766 €251,86
		TEAM	-	-	-	-
	INTAKE MANIFOLDS	Ø 22 x 24,5	0213222B €52,50	0213222B €52,50	0213222B €52,50	02 8732B €52,50
		RUBBER NBR	0213661B €65,10	0213661B €65,10	0213661B €65,10	02 9732B €65,10
		RUBBER FKM	02 8857B €52,50	02 8857B €52,50	02 8857B €52,50	02 8856B €52,50
	INTAKE MANIFOLDS	Ø 22 x 28	0213662B €65,10	0213662B €65,10	0213662B €65,10	02 9441B €65,10
		RUBBER FKM	2014524 €52,02	2014524 €52,02	2014524 €52,02	2014520 €52,02
	INTAKE MANIFOLDS X360	Ø 22 x 24,5	2014525 €52,02	2014525 €52,02	2014525 €52,02	2014519 €52,02
		RUBBER FKM	2013847 €52,02	2013847 €52,02	2013847 €52,02	2013802 €52,02
		RUBBER FKM	-	-	-	-
	REED VALVE	CARBON FIBRE	2711817.CO €52,25 VL14	2711817.CO €52,25 VL14	2711817.CO €52,25 VL14	27 9490.CO €52,25 VL13
	REED VALVE	CARBON FIBRE	-	-	-	2713719.CO *19* €57,68 VL16
	TEAM	-	-	-	-	-
	DIGITRONIC EPROM	ELECTRONIC DIGITAL CONTROLLER	-	-	-	55 9002 €189,75
	INNER ROTOR IGNITION	-	5514690 €328,50	5514690 €328,50	5514690 €328,50	5514689 €318,50
	INNER ROTOR IGNITION	TEAM	5515002 €350,00	5515002 €350,00	5515002 €350,00	-

19 - for the ASSEMBLY MODIFY the CRANKCASE

38 - IT IS NOT MODULAR-head

39 - WE SUGGEST TO USE bearings : 6614105EA € 82,00

APRILIA

SONIC	SONIC	SPORTCITY ONE STREET euro 2	SR 1994->	SR (carb.) 2004->	SR NETSCAPER	SR R (carb.)	SR RACING
				(PIAGGIO)	(MINARELLI)	(PIAGGIO)	(MINARELLI)
50 2T	50 2T LC	50 2T	50 2T	50 2T LC	50 2T LC	50 2T LC	50 2T LC
31 8403 ¹ € 184,06 (10)	31 8559 ¹ € 209,16 (10)	31 8862 € 174,92 (12)	31 8403 ¹ € 184,06 (10)	31 8865 € 213,72 (12)	31 8559 ¹ € 209,16 (10)	31 8865 € 213,72 (12)	31 8559 ¹ € 209,16 (10)
31 8440 € 267,15 Ø 47,6 (12)	31 8460 € 301,54 Ø 47,6 (12)	31 8398 € 267,15 Ø 47,6 (12)	31 8440 € 267,15 Ø 47,6 (12)	31 8455 € 301,54 Ø 47,6 (12)	31 8460 € 301,54 Ø 47,6 (12)	31 8455 € 301,54 Ø 47,6 (12)	31 8460 € 301,54 Ø 47,6 (12)
-	-	-	-	3111584 € 324,71 (12)	-	3111584 € 324,71 (12)	-
53 8009 € 175,50	53 8009 € 175,50	53 7600 € 175,50	53 8009 € 175,50	53 7600 € 175,50	53 8009 € 175,50	53 7600 € 175,50	53 8009 € 175,50
-	3111511 € 302,14	31 8881 *38* € 181,70	-	31 8884 € 284,08	3111511 € 302,14	31 8884 € 284,08	3111511 € 302,14
-	3112642 € 357,72	-	-	3115142 € 376,00	3112642 € 357,72	3115142 € 376,00	3112642 € 357,72
-	-	-	-	3113030 € 367,50	-	3113030 € 367,50	-
-	53 8855 € 177,14 53 8009 € 175,50	53 9212 € 285,15	-	53 9212 € 285,15	53 8855 € 177,14 53 8009 € 175,50	53 9212 € 285,15	53 8855 € 177,14 53 8009 € 175,50
-	5315973 € 480,00 5314548 € 465,00	5316005 *39* € 478,00	-	5316005 *39* € 478,00	5315973 € 480,00 5314548 € 465,00	5316005 *39* € 478,00	5315973 € 480,00 5314548 € 465,00
-	-	-	-	3113042 € 367,50	-	3113042 € 367,50	-
-	5313275 *79* € 450,00	-	-	5313270 *73* € 450,00	5313275 *79* € 450,00	5313270 *73* € 450,00	5313275 *79* € 450,00
-	3115374 € 430,00	-	-	3115385 € 430,00	3115374 € 430,00	3115385 € 430,00	3115374 € 430,00
-	5316039 *79* € 465,00	-	-	5316029 € 465,00	5316039 *79* € 465,00	5316029 € 465,00	5316039 *79* € 465,00
PG.473	PG.473	6614105EA € 82,00	PG.473	6614105EA € 82,00	PG.473	6614105EA € 82,00	PG.473
-	3212825 € 308,06 DISMANTLED	-	-	-	3212825 € 308,06 DISMANTLED	-	3212825 € 308,06 DISMANTLED
-	-	32 9834 € 377,08	32 7562 € 266,00	-	-	-	-
3214763 € 366,18	3214763 € 366,18	-	3214763 € 366,18	-	3214763 € 366,18	-	3214763 € 366,18
-	-	-	-	3215341 € 366,18	-	3215341 € 366,18	-
-	3215198 € 366,18	-	-	3215134 € 366,18	3215198 € 366,18	3215134 € 366,18	3215198 € 366,18
-	3216827 € 366,18	-	-	3216158 € 366,18	3216827 € 366,18	3216158 € 366,18	3216827 € 366,18
1611021 € 129,40	1611021 € 129,40	1611021 € 129,40	1611021 € 129,40	1611023 € 132,14	1611021 € 129,40	1611023 € 132,14	1611021 € 129,40
1611021.T € 202,60	1611021.T € 202,60	1611021.T € 202,60	1611021.T € 202,60	1611021.T € 202,60	1611021.T € 202,60	1611021.T € 202,60	1611021.T € 202,60
1613890.TO € 210,60	1613890.TO € 210,60	1613890.TO € 210,60	1613890.TO € 210,60	1613890.TO € 210,60	1613890.TO € 210,60	1613890.TO € 210,60	1613890.TO € 210,60
1611013 € 217,38	1611013 € 217,38	1611009 € 217,99	1611013 € 217,38	1611009 € 217,99	1611013 € 217,38	1611009 € 217,99	1611013 € 217,38
1614022 € 251,86	1614022 € 251,86	1613766 € 251,86	1614022 € 251,86	1613766 € 251,86	1614022 € 251,86	1613766 € 251,86	1614022 € 251,86
0213222B € 52,50	0213222B € 52,50	02 8732B € 52,50	0213222B € 52,50	02 8732B € 52,50	0213222B € 52,50	02 8732B € 52,50	0213222B € 52,50
0213661B € 65,10	0213661B € 65,10	02 9732B € 65,10	0213661B € 65,10	02 9732B € 65,10	0213661B € 65,10	02 9732B € 65,10	0213661B € 65,10
02 8857B € 52,50	02 8857B € 52,50	02 8856B € 52,50	02 8857B € 52,50	02 8856B € 52,50	02 8857B € 52,50	02 8856B € 52,50	02 8857B € 52,50
0213662B € 65,10	0213662B € 65,10	02 9441B € 65,10	0213662B € 65,10	02 9441B € 65,10	0213662B € 65,10	02 9441B € 65,10	0213662B € 65,10
2014524 € 52,02	2014524 € 52,02	2014520 € 52,02	2014524 € 52,02	2014520 € 52,02	2014524 € 52,02	2014520 € 52,02	2014524 € 52,02
2014525 € 52,02	2014525 € 52,02	2014519 € 52,02	2014525 € 52,02	2014519 € 52,02	2014525 € 52,02	2014519 € 52,02	2014525 € 52,02
2013847 € 52,02	2013847 € 52,02	2013802 € 52,02	2013847 € 52,02	2013802 € 52,02	2013847 € 52,02	2013802 € 52,02	2013847 € 52,02
2711817.CO € 52,25 VL14	2711817.CO € 52,25 VL14	27 9490.CO € 52,25 VL13	2711817.CO € 52,25 VL14	27 9490.CO € 52,25 VL13	2711817.CO € 52,25 VL14	27 9490.CO € 52,25 VL13	2711817.CO € 52,25 VL14
-	-	2713719.CO *19* € 57,68 VL16	-	2713719.CO *19* € 57,68 VL16	-	2713719.CO *19* € 57,68 VL16	-
-	-	55 9002 € 189,75	-	55 9002 € 189,75	-	55 9002 € 189,75	-
5514690 € 328,50 5515002 € 350,00	5514690 € 328,50 5515002 € 350,00	5514689 € 318,50	5514690 € 328,50 5515002 € 350,00	5514691 € 328,50 5515001 € 350,00	5514690 € 328,50 5515002 € 350,00	5514691 € 328,50 5515001 € 350,00	5514690 € 328,50 5515002 € 350,00

73 - Crankcase MODIFICATIONS: BORING - WE SUGGEST TO USE bearings 6614105EA
 75 - ONLY for CROSS model: Malossi CYLINDER 3113262 € 357,72 WITH CRANKSHAFT 53 8855 € 177,14 or 5315973 € 480,00
 79 - Crankcase MODIFICATIONS: BORING - TO COUPLE ONLY with Multivar 5112800 or 5115823



MHR[®]

MALOSSİ HYPER RACING

Scooter 50

with ENGINE 

APRILIA

AREA 51

RALLY

RALLY

SCARABEO
STREET

(MINARELLI)

(MINARELLI)

(PIAGGIO)

50 2T

LC

50 2T

















50 2T

LC

50 2T

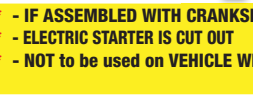
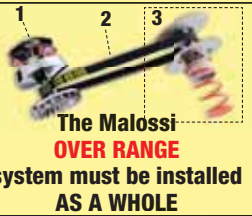

	MULTIVAR VARIATOR	5113161 € 78,28	5113161 € 78,28	5113161 € 78,28	-
	MULTIVAR TEAM VARIATOR	-	-	-	5112645 € 77,25
	X K BELT BELT	6112729 € 25,23	6112729 € 25,23	6112729 € 25,23	61 9535 € 28,72
	VENTILVAR HALF-PULLEY	61 7152 € 21,71	61 7152 € 21,71	61 7152 € 21,71	6113416B *59* € 36,72
	TORSION CONTROLLER ANTIFRICTION FIFTH WHEEL	2512827 € 4,45	2512827 € 4,45	2512827 € 4,45	2512828 € 4,45
	TORQUE DRIVER MOBILE DRIVEN SPLIT PULLEY	61 9223 € 85,57	61 8312 (Ø 33) € 85,57 61 9223 (Ø 34) € 85,57	61 8312 (Ø 33) € 85,57 61 9223 (Ø 34) € 85,57	61 9100 € 85,57
	DELTA CLUTCH ADJUSTABLE CLUTCH	52 9451 € 77,89	52 7643 (Ø 105) € 77,89 52 9451 (Ø 107) € 77,89	52 7643 (Ø 105) € 77,89 52 9451 (Ø 107) € 77,89	52 7880 € 77,89
	WING CLUTCH BELL CLUTCH BELL (FINNED RING)	7714313 € 90,00 Ø 107	7714313 € 90,00 Ø 107	7714313 € 90,00 Ø 107	7714147 € 90,00 Ø 107
	DELTA SYSTEM MHR BELL + ADJUSTABLE CLUTCH	5214739 € 156,00	5214739 € 156,00	5214739 € 156,00	5214738 € 156,00
	ROLLER CRANKCASE GEAR-BOX COVERS	2515482 € 95,00	2515482 € 95,00	2515482 € 95,00	2514521 *66* € 95,00
	ROLLER CRANKCASE TEAM GEAR-BOX COVERS	-	-	-	2514603 *66* € 95,00
	PINWHEEL SHAFT	6714748 € 60,18	6714748 € 60,18	6714748 € 60,18	6714530 € 66,30
	GEARS HTQ PRIMARY	6714039 € 57,67 z 13/44	6714039 € 57,67 z 13/44	6714039 € 57,67 z 13/44	-
	GEARS HTQ (PIAGGIO) PRIMARY	-	-	-	-
	COUPLING Ø 17	-	-	-	-
	COUPLING Ø 18	-	-	-	-
	GEARS HTQ SECONDARY	6714774 z 15/42 € 67,32 6714775 z 14/43 € 67,32	-	-	6711135 € 58,86 z 15/55
	SPLINED COUPLING Ø 17	-	-	-	-
	COUPLING Ø 18	-	-	-	-
	SECOND ROLLER GEAR (COUPLING)	-	-	-	-
KIT	OVER RANGE / OVER RANGE ALUMINUM	6112811 € 272,85 6115821 € 365,00	6112811 € 272,85 6115821 € 365,00	6112811 € 272,85 6115821 € 365,00	-
	1 MULTIVAR / ALUMINUM VARIATOR	5112800 € 87,55 5115823 € 88,60 (*56*)	5112800 € 87,55 5115823 € 88,60	5112800 € 87,55 5115823 € 88,60	-
	2 X K BELT BELT	6114116 € 38,25	6114116 € 38,25	6114116 € 38,25	-
	2 X K BELT TEAM / ALUMINUM	6115822 € 44,88	6115822 € 44,88	6115822 € 44,88	-
	3 REAR PULLEY SYSTEM / ALUMINUM REAR PULLEY	61 9733 € 170,82 6114590 € 275,31	61 9733 € 170,82 6114590 € 275,31	61 9733 € 170,82 6114590 € 275,31	-
	WHOOB DISC FRONT BRAKE DISC	-	6212603 € 72,56 1995->	6212603 € 72,56 1996->	-
	WHOOB DISC REAR BRAKE DISC	-	-	-	-
	BRAKE PADS MHR FRONT ORGANIC BRAKE PADS	6215080 € 6,00 1998->	6215080 € 6,00 1995->	6215080 € 6,00 1996->	6215080 € 6,00
	BRAKE PADS MHR SYNT FRONT SINTERED BRAKE PADS	6215007 € 11,96 1998->	6215007 € 11,96 1998->	6215007 € 11,96 1996->	6215007 € 11,96
	BRAKE PADS MHR REAR ORGANIC BRAKE PADS	6215080 € 6,00 1998->	-	6215080 € 6,00 1996->	-
	BRAKE PADS MHR SYNT REAR SINTERED BRAKE PADS	6215007 € 11,96 1998->	-	6215007 € 11,96 1996->	-
	RADIATOR / RADIATOR TEAM	-	-	-	-
	RS24/10 - RS24/10-R FRONT SHOCK ABSORBER	-	-	-	-
	RS24/10 - RS24/10-R REAR SHOCK ABSORBER	-	4614223 € 430,00	4614223 € 430,00	-
	RS24/10-R FRONT + REAR	-	-	-	-

56 - IF ASSEMBLED WITH CRANKSHAFTS 5313275 (5312810-5316048), USE 2015832 € 40,17

59 - ELECTRIC STARTER IS CUT OUT

66 - NOT to be used on VEHICLE WITH ORIGINAL PRIMARY GEARS

APRILIA

307

SONIC		SONIC		SPORTCITY ONE STREET euro 2		SR 1994->		SR (carb.) 2004->		SR NETSCAPER		SR R (carb.)		SR RACING	
								(PIAGGIO)		(MINARELLI)		(PIAGGIO)		(MINARELLI)	
50 2T	🛡️	50 2T	LC	50 2T	🛡️	50 2T	🛡️	50 2T	LC	50 2T	LC	50 2T	LC	50 2T	LC
5113161 € 78,28		5113161 € 78,28		-		5113161 € 78,28		-		5113161 € 78,28		-		5113161 € 78,28	
-		-		5112645 € 77,25		-		5112645 € 77,25		-		5112645 € 77,25		-	
6112742 € 26,33		6112742 € 26,33		61 9535 € 28,72		6112729 € 25,23		6114118 € 38,25		6112729 € 25,23		6114118 € 38,25		6112729 € 25,23	
61 7152 € 21,71		61 7152 € 21,71		6113416B *59* € 36,72		61 7152 € 21,71		6113416B *59* € 36,72		61 7152 € 21,71		6113416B *59* € 36,72		61 7152 € 21,71	
2512827 € 4,45		2512827 € 4,45		2512828 € 4,45		2512827 € 4,45		2512828 € 4,45		2512827 € 4,45		2512828 € 4,45		2512827 € 4,45	
61 9223 € 85,57		61 9223 € 85,57		61 9100 € 85,57		61 8312 (Ø 33) € 85,57 61 9223 (Ø 34) € 85,57		61 9100 € 85,57		61 9223 € 85,57		61 9100 € 85,57		61 9223 € 85,57	
52 9451 € 77,89		52 9451 € 77,89		52 7880 € 77,89		52 7643 (Ø 105) € 77,89 52 9451 (Ø 107) € 77,89		52 7880 € 77,89		52 9451 € 77,89		52 7880 € 77,89		52 9451 € 77,89	
7714313 € 90,00 Ø 107		7714313 € 90,00 Ø 107		7714147 € 90,00 Ø 107		-		7714147 € 90,00 Ø 107		7714313 € 90,00 Ø 107		7714147 € 90,00 Ø 107		7714313 € 90,00 Ø 107	
5214739 € 156,00		5214739 € 156,00		5214738 € 156,00		-		5214738 € 156,00		5214739 € 156,00		5214738 € 156,00		5214739 € 156,00	
-		-		2514521 *66* € 95,00		2515482 € 95,00		2514521 *66* € 95,00		2515482 € 95,00		2514521 *66* € 95,00		2515482 € 95,00	
-		-		2514603 *66* € 95,00		-		2514603 *66* € 95,00		-		2514603 *66* € 95,00		-	
-		-		6714530 € 66,30		6714748 € 60,18		6714530 € 66,30		6714748 € 60,18		6714530 € 66,30		6714748 € 60,18	
67 7014 € 68,44 z 15/41		67 7014 € 68,44 z 15/41		-		6714039 € 57,67 z 13/44		-		6714039 € 57,67 z 13/44		-		6714039 € 57,67 z 13/44	
-		-		-		-		67 9080 z 14/39 € 60,41 6713339 z 15/38 € 61,70		-		67 9080 z 14/39 € 60,41 6713339 z 15/38 € 61,70		-	
-		-		-		-		-		-		-		-	
-		-		6711135 € 58,86 z 15/55		6714774 z 15/42 € 67,32 6714775 z 14/43 € 67,32		67 9966 € 65,00 z 13/48		6714774 z 15/42 € 67,32 6714775 z 14/43 € 67,32		67 9966 € 65,00 z 13/48		6714774 z 15/42 € 67,32 6714775 z 14/43 € 67,32	
-		-		-		-		-		-		-		-	
-		-		-		-		-		-		-		-	
-		-		-		-		67 9967 € 71,36 z 13/48 (17)		-		67 9967 € 71,36 z 13/48 (17)		-	
6112812 € 272,85 6116249 € 365,00		6112812 € 272,85 6116249 € 365,00		-		6112811 € 272,85 6115821 € 365,00		6114219 € 262,65 6115781 € 365,00		6112811 € 272,85 6115821 € 365,00		6114219 € 262,65 6115781 € 365,00		6112811 € 272,85 6115821 € 365,00	
5112800 € 87,55 5115823 € 88,60		5112800 € 87,55 5115823 € 88,60 (*56*)		-		5112800 € 87,55 5115823 € 88,60		5112645 € 77,25 5115644 € 87,55		5112800 € 87,55 5115823 € 88,60 (*56*)		5112645 € 77,25 5115644 € 87,55		5112800 € 87,55 5115823 € 88,60 (*56*)	
6111108 € 27,80		6111108 € 27,80		-		6114116 € 38,25		6114118 € 38,25		6114116 € 38,25		6114118 € 38,25		6114116 € 38,25	
-		-		-		6115822 € 44,88		6115668 € 44,88		6115822 € 44,88		6115668 € 44,88		6115822 € 44,88	
6111121 € 169,52 6115991 € 275,31		6111121 € 169,52 6115991 € 275,31		-		61 9733 € 170,82 6114590 € 275,31		6113101 € 174,40 6114582 € 275,31		61 9733 € 170,82 6114590 € 275,31		6113101 € 174,40 6114582 € 275,31		61 9733 € 170,82 6114590 € 275,31	
-		-		-		6212603 € 72,56 <-1996		6212603 € 72,56		6212603 € 72,56 1993->		6212603 € 72,56		6212603 € 72,56 1993->	
-		-		-		-		-		-		-		-	
6215080 € 6,00 1997->		6215080 € 6,00 1997->		-		62 9083 € 6,20 <-1996		62 9083 € 6,20		62 9083 1993->96 € 6,20 6215080 1997-> € 6,00		62 9083 € 6,20		62 9083 1993->96 € 6,20 6215080 1997-> € 6,00	
6215007 € 11,96 1997->		6215007 € 11,96 1997->		-		6215008 € 11,96 <-1996		6215008 € 11,96		6215007 1997-> € 11,96 6215008 1993->96 € 11,96		6215008 € 11,96		6215007 1997-> € 11,96 6215008 1993->96 € 11,96	
-		-		-		-		-		6215080 € 6,00 1997->		-		6215080 € 6,00 1997->	
-		-		-		-		6215019 € 16,64		6215007 € 11,96 1997->		6215019 € 16,64		6215007 € 11,96 1997->	
-		-		-		-		-		-		-		-	
-		-		-		-		-		-		-		-	
-		-		-		4614223 € 430,00		4614223 € 430,00		4614223 € 430,00		4614223 € 430,00		4614223 € 430,00	
-		-		-		-		-		-		-		-	

SCOOTER 2T MHR



Scooter 50

with ENGINE

APRILIA

BENELLI

SR REPLICA
<-1999

SR STEALTH

SR WWW

491 GT

(MINARELLI)

(MINARELLI)

50 2T

LC

50 2T

LC

50 2T

50 2T

TEAM Cylinder and crankshaft MUST BE INSTALLED AS A WHOLE

	CYLINDER+HEAD Ø 40 (pin)	31 8559 1 €209,16 (10)	31 8559 1 €209,16 (10)	31 8403 1 €184,06 (10)	31 8403 1 €184,06 (10)
	CYLINDER+HEAD Ø 47-47,6 (pin)	31 8460 €301,54 Ø 47,6 (12)	31 8460 €301,54 Ø 47,6 (12)	31 8440 €267,15 Ø 47,6 (12)	31 8440 €267,15 Ø 47,6 (12)
	CYLINDER+HEAD Ø 47,6 (pin) TEAM Replica	-	-	-	-
	CRANKSHAFTS RHQ PIN Ø 12 STROKE 39 mm CONNECTING ROD 80	53 8009 €175,50	53 8009 €175,50	53 8009 €175,50	53 8009 €175,50
	CYLINDER+HEAD Ø 40 TEAM	3111511 €302,14	3111511 €302,14	-	-
	CYLINDER+HEAD Ø 47,6 TEAM - TEAM 2 STROKE 39 mm C.ROD 80 - 85	3112642 €357,72	3112642 €357,72	-	-
	CYLINDER+HEAD Ø 50 BIG BORE STROKE 39 mm C.ROD 85	-	-	-	-
	CRANKSHAFTS RHQ PIN Ø 12 STROKE 39 mm C.ROD 85 - 80	53 8855 €177,14 53 8009 €175,50	53 8855 €177,14 53 8009 €175,50	-	-
	CRANKSHAFTS RHQ PIN Ø 12 - 13 TEAM STROKE 39 mm C.ROD 85 - 80	5315973 €480,00 5314548 €465,00	5315973 €480,00 5314548 €465,00	-	-
	CYLINDER+HEAD Ø 50 BIG BORE STROKE 44 mm C.ROD 85	-	-	-	-
	CRANKSHAFTS RHQ PIN Ø 13 BIG BORE STROKE 44 mm C.ROD 85	5313275 *79* €450,00	5313275 *79* €450,00	-	-
	CYLINDER+HEAD Ø 52 BIG BORE testa rossa STROKE 44 mm C.ROD 90	3115374 €430,00	3115374 €430,00	-	-
	CRANKSHAFTS RHQ PIN Ø 13 TEAM STROKE 44 mm C.ROD 90	5316039 *79* €465,00	5316039 *79* €465,00	-	-
	RADIAL ROLLER BEARING Pg. 473	PG.473	PG.473	PG.473	PG.473
	EXHAUST SYSTEM SCOOTER RACING Ø 40	3212825 €308,06 DISMANTLED	3212825 €308,06 DISMANTLED	-	-
	EXHAUST SYSTEM SCOOTER RACING Ø 47 - 47,6	-	-	-	32 7562 €266,00
	EXHAUST SYSTEM SCOOTER RACING Ø 47,6 TEAM 2	3214763 €366,18	3214763 €366,18	3214763 €366,18	3214763 €366,18
	EXHAUST SYSTEM SCOOTER RACING Ø 47,6 TEAM 3	-	-	-	-
	EXHAUST SYSTEM SCOOTER RACING Ø 50 BIG BORE 2 Ø 50 STROKE 39 - 44 mm	3215198 €366,18	3215198 €366,18	-	-
	EXHAUST SYSTEM SCOOTER RACING Ø 52 BIG BORE Ø 52 STROKE 44 mm	3216827 €366,18	3216827 €366,18	-	-
		CARBURETTOR KIT PHBG Ø 19	1611021 €129,40	1611021 €129,40	1611021 €129,40
PHBG Ø 19 TEAM		1611021.T €202,60	1611021.T €202,60	1611021.T €202,60	-
PHBG Ø 21 TEAM		1613890.TO €210,60	1613890.TO €210,60	1613890.TO €210,60	-
PHBL Ø 25		1611013 €217,38	1611013 €217,38	1611013 €217,38	1611013 €217,38
VHST Ø 28 TEAM		1614022 €251,86	1614022 €251,86	1614022 €251,86	1614022 €251,86
		INTAKE MANIFOLDS Ø 22 x 24,5 RUBBER NBR	0213222B €52,50	0213222B €52,50	0213222B €52,50
	RUBBER FKM	0213661B €65,10	0213661B €65,10	0213661B €65,10	0213661B €65,10
	INTAKE MANIFOLDS Ø 22 x 28 RUBBER NBR	02 8857B €52,50	02 8857B €52,50	02 8857B €52,50	02 8857B €52,50
	RUBBER FKM	0213662B €65,10	0213662B €65,10	0213662B €65,10	0213662B €65,10
	INTAKE MANIFOLDS X360 Ø 22 x 24,5 RUBBER FKM	2014524 €52,02	2014524 €52,02	2014524 €52,02	2014524 €52,02
	RUBBER FKM	2014525 €52,02	2014525 €52,02	2014525 €52,02	2014525 €52,02
	RUBBER FKM	2013847 €52,02	2013847 €52,02	2013847 €52,02	2013847 €52,02
	REED VALVE CARBON FIBRE	2711817.CO €52,25 VL14	2711817.CO €52,25 VL14	2711817.CO €52,25 VL14	2711817.CO €52,25 VL14
	REED VALVE CARBON FIBRE TEAM	-	-	-	-
	DIGITRONIC EPROM ELECTRONIC DIGITAL CONTROLLER	-	-	-	-
INNER ROTOR IGNITION	5514690 €328,50	5514690 €328,50	5514690 €328,50	5514690 €328,50	
INNER ROTOR IGNITION TEAM	5515002 €350,00	5515002 €350,00	5515002 €350,00	5515002 €350,00	

19 - for the ASSEMBLY MODIFY the CRANKCASE

39 - WE SUGGEST TO USE bearings : 6614105EA € 82,00

73 - Crankcase MODIFICATIONS: BORING - WE SUGGEST TO USE bearings 6614105EA

BENELLI				BETA			DERBI
491 SPORT	K2	K2	NAKED	ARK	ARK	EIKON	GP1
(MINARELLI)							
50 2T	LC	50 2T	LC	50 2T	LC	50 2T	LC
31 8559 1 € 209,16 (10)	31 8403 1 € 184,06 (10)	31 8559 1 € 209,16 (10)	31 8403 1 € 184,06 (10)	31 8403 1 € 184,06 (10)	31 8559 1 € 209,16 (10)	31 8559 1 € 209,16 (10)	31 8865 € 213,72 (12)
31 8460 € 301,54 Ø 47,6 (12)	31 8440 € 267,15 Ø 47,6 (12)	31 8460 € 301,54 Ø 47,6 (12)	31 8440 € 267,15 Ø 47,6 (12)	31 8440 € 267,15 Ø 47,6 (12)	31 8460 € 301,54 Ø 47,6 (12)	31 8460 € 301,54 Ø 47,6 (12)	31 8455 € 301,54 Ø 47,6 (12)
-	-	-	-	-	-	-	3111584 € 324,71 (12)
53 8009 € 175,50	53 8009 € 175,50	53 8009 € 175,50	53 8009 € 175,50	53 8009 € 175,50	53 8009 € 175,50	53 8009 € 175,50	53 7600 € 175,50
3111511 € 302,14	-	-	-	-	-	3111511 € 302,14	31 8884 € 284,08
3112642 € 357,72	-	*75*	-	-	*75*	3112642 € 357,72	3115142 € 376,00
-	-	-	-	-	-	-	3113030 € 367,50
53 8855 € 177,14 53 8009 € 175,50	-	*75*	-	-	*75*	53 8855 € 177,14 53 8009 € 175,50	53 9212 € 285,15
5315973 € 480,00 5314548 € 465,00	-	*75*	-	-	*75*	5315973 € 480,00 5314548 € 465,00	5316005 *39* € 478,00
-	-	-	-	-	-	-	3113042 € 367,50
5313275 *79* € 450,00	-	-	-	-	-	5313275 *79* € 450,00	5313270 *73* € 450,00
3115374 € 430,00	-	-	-	-	-	3115374 € 430,00	3115385 € 430,00
5316039 *79* € 465,00	-	-	-	-	-	5316039 *79* € 465,00	5316029 € 465,00
PG.473	PG.473	PG.473	PG.473	PG.473	PG.473	PG.473	6614105EA € 82,00
3212825 € 308,06 DISMANTLED	-	-	-	-	-	3212825 € 308,06 DISMANTLED	-
32 7562 € 266,00	32 7562 € 266,00	-	32 7562 € 266,00	-	-	32 7562 € 266,00	32 9027 € 314,23
3214763 € 366,18	3214763 € 366,18	3214763 € 366,18	3214763 € 366,18	3214763 € 366,18	3214763 € 366,18	3214763 € 366,18	-
-	-	-	-	-	-	-	3215341 € 366,18
3215198 € 366,18	-	-	-	-	-	3215198 € 366,18	3215134 € 366,18
3216827 € 366,18	-	-	-	-	-	3216827 € 366,18	3216158 € 366,18
1611021 € 129,40	1611021 € 129,40	1611021 € 129,40	1611021 € 129,40	1611021 € 129,40	1611021 € 129,40	1611021 € 129,40	1611023 € 132,14
1611021.T € 202,60	-	-	-	-	1611021.T € 202,60	1611021.T € 202,60	-
1613890.TO € 210,60	-	-	-	-	1613890.TO € 210,60	1613890.TO € 210,60	-
1611013 € 217,38	1611013 € 217,38	1611013 € 217,38	1611013 € 217,38	1611013 € 217,38	1611013 € 217,38	1611013 € 217,38	1611009 € 217,99
1614022 € 251,86	1614022 € 251,86	1614022 € 251,86	1614022 € 251,86	1614022 € 251,86	1614022 € 251,86	1614022 € 251,86	1613766 € 251,86
0213222B € 52,50	0213222B € 52,50	0213222B € 52,50	0213222B € 52,50	0213222B € 52,50	0213222B € 52,50	0213222B € 52,50	02 8732B € 52,50
0213661B € 65,10	0213661B € 65,10	0213661B € 65,10	0213661B € 65,10	0213661B € 65,10	0213661B € 65,10	0213661B € 65,10	02 9732B € 65,10
02 8857B € 52,50	02 8857B € 52,50	02 8857B € 52,50	02 8857B € 52,50	02 8857B € 52,50	02 8857B € 52,50	02 8857B € 52,50	02 8856B € 52,50
0213662B € 65,10	0213662B € 65,10	0213662B € 65,10	0213662B € 65,10	0213662B € 65,10	0213662B € 65,10	0213662B € 65,10	02 9441B € 65,10
2014524 € 52,02	2014524 € 52,02	2014524 € 52,02	2014524 € 52,02	2014524 € 52,02	2014524 € 52,02	2014524 € 52,02	2014520 € 52,02
2014525 € 52,02	2014525 € 52,02	2014525 € 52,02	2014525 € 52,02	2014525 € 52,02	2014525 € 52,02	2014525 € 52,02	2014519 € 52,02
2013847 € 52,02	2013847 € 52,02	2013847 € 52,02	2013847 € 52,02	2013847 € 52,02	2013847 € 52,02	2013847 € 52,02	2013802 € 52,02
2711817.CO € 52,25 VL14	2711817.CO € 52,25 VL14	2711817.CO € 52,25 VL14	2711817.CO € 52,25 VL14	2711817.CO € 52,25 VL14	2711817.CO € 52,25 VL14	2711817.CO € 52,25 VL14	27 9490.CO € 52,25 VL13
-	-	-	-	-	-	-	2713719.CO *19* € 57,68 VL16
-	-	-	-	-	-	-	55 9002 € 189,75
5514690 € 328,50 5515002 € 350,00	5514690 € 328,50 5515002 € 350,00	5514690 € 328,50 5515002 € 350,00	5514690 € 328,50 5515002 € 350,00	5514690 € 328,50 5515002 € 350,00	5514690 € 328,50 5515002 € 350,00	5514690 € 328,50 5515002 € 350,00	5514690 € 328,50 5515002 € 350,00

75 - ONLY for CROSS model: Malossi CYLINDER 3113262 € 357,72 WITH CRANKSHAFT 53 8855 € 177,14 or 5315973 € 480,00

79 - Crankcase MODIFICATIONS: BORING - TO COUPLE ONLY with Multivar 5112800 or 5115823



Scooter 50

with ENGINE

APRILIA

BENELLI

SR REPLICA
<-1999

SR STEALTH

SR WWW

491 GT

(MINARELLI)

(MINARELLI)

50 2T

LC

50 2T

LC

50 2T

50 2T

	MULTIVAR VARIATOR	5113161 € 78,28	5113161 € 78,28	5113161 € 78,28	5113161 € 78,28
	MULTIVAR TEAM VARIATOR	-	-	-	-
	X K BELT BELT	6112729 € 25,23	6112729 € 25,23	6112729 € 25,23	6112729 € 25,23
	VENTILVAR HALF-PULLEY	61 7152 € 21,71	61 7152 € 21,71	61 7152 € 21,71	61 7152 € 21,71
	TORSION CONTROLLER ANTIFRICTION FIFTH WHEEL	2512827 € 4,45	2512827 € 4,45	2512827 € 4,45	2512827 € 4,45
	TORQUE DRIVER MOBILE DRIVEN SPLIT PULLEY	61 8312 (Ø 33) € 85,57 61 9223 (Ø 34) € 85,57	61 9223 € 85,57	61 9223 € 85,57	61 8312 (Ø 33) € 85,57 61 9223 (Ø 34) € 85,57
	DELTA CLUTCH ADJUSTABLE CLUTCH	52 7643 (Ø 105) € 77,89 52 9451 (Ø 107) € 77,89	52 9451 € 77,89	52 9451 € 77,89	52 7643 (Ø 105) € 77,89 52 9451 (Ø 107) € 77,89
	WING CLUTCH BELL CLUTCH BELL (FINNED RING)	-	7714313 € 90,00 Ø 107	7714313 € 90,00 Ø 107	7714313 € 90,00 Ø 107
	DELTA SYSTEM MHR BELL + ADJUSTABLE CLUTCH	-	5214739 € 156,00	5214739 € 156,00	5214739 € 156,00
	ROLLER CRANKCASE GEAR-BOX COVERS	2515482 € 95,00	2515482 € 95,00	2515482 € 95,00	2515482 € 95,00
	ROLLER CRANKCASE TEAM GEAR-BOX COVERS	-	-	-	-
	PINWHEEL SHAFT	6714748 € 60,18	6714748 € 60,18	6714748 € 60,18	6714748 € 60,18
	GEARS HTQ PRIMARY	6714039 € 57,67 z 13/44	6714039 € 57,67 z 13/44	6714039 € 57,67 z 13/44	6714039 € 57,67 z 13/44
	GEARS HTQ (PIAGGIO) PRIMARY	-	-	-	-
	COUPLING Ø 17	-	-	-	-
	COUPLING Ø 18	-	-	-	-
	GEARS HTQ SECONDARY	6714774 z 15/42 € 67,32 6714775 z 14/43 € 67,32	6714774 z 15/42 € 67,32 6714775 z 14/43 € 67,32	6714774 z 15/42 € 67,32 6714775 z 14/43 € 67,32	-
	SPLINED COUPLING Ø 17	-	-	-	-
	COUPLING Ø 18	-	-	-	-
	SECOND ROLLER GEAR (COUPLING)	-	-	-	-
KIT	OVER RANGE / OVER RANGE ALUMINUM	6112811 € 272,85 6115821 € 365,00	6112811 € 272,85 6115821 € 365,00	6112811 € 272,85 6115821 € 365,00	6112811 € 272,85 6115821 € 365,00
	1 MULTIVAR / ALUMINUM VARIATOR	5112800 € 87,55 5115823 € 88,60 (*56*)	5112800 € 87,55 5115823 € 88,60 (*56*)	5112800 € 87,55 5115823 € 88,60	5112800 € 87,55 5115823 € 88,60
	2 X K BELT BELT	6114116 € 38,25	6114116 € 38,25	6114116 € 38,25	6114116 € 38,25
	2 X K BELT TEAM / ALUMINUM	6115822 € 44,88	6115822 € 44,88	6115822 € 44,88	6115822 € 44,88
	3 REAR PULLEY SYSTEM / ALUMINUM REAR PULLEY	61 9733 € 170,82 6114590 € 275,31	61 9733 € 170,82 6114590 € 275,31	61 9733 € 170,82 6114590 € 275,31	61 9733 € 170,82 6114590 € 275,31
	WHOO DISC FRONT BRAKE DISC	6212603 € 72,56 1993->	6212603 € 72,56 1993->	6212603 € 72,56 1993->	-
	WHOO DISC REAR BRAKE DISC	-	-	-	-
	BRAKE PADS MHR ORGANIC BRAKE PADS	FRONT 62 9083 € 6,20 1993->	FRONT 62 9083 1993->96 € 6,20 6215080 1997-> € 6,00	FRONT 62 9083 1993->96 € 6,20 6215080 1997-> € 6,00	FRONT 6215080 € 6,00 1997->
	BRAKE PADS MHR SYNT SINTERED BRAKE PADS	FRONT 6215007 € 11,96 1993->	FRONT 6215007 1997-> € 11,96 6215008 1993->96 € 11,96	FRONT 6215007 1997-> € 11,96 6215008 1993->96 € 11,96	FRONT 6215007 € 11,96 1997->
	BRAKE PADS MHR ORGANIC BRAKE PADS	REAR -	REAR 6215080 € 6,00 1997->	REAR 6215080 € 6,00 1997->	-
	BRAKE PADS MHR SYNT SINTERED BRAKE PADS	REAR -	REAR 6215007 € 11,96 1997->	REAR 6215007 € 11,96 1997->	-
	RADIATOR / RADIATOR TEAM	-	-	-	-
	RS24/10 - RS24/10-R FRONT SHOCK ABSORBER	-	-	-	-
	RS24/10 - RS24/10-R REAR SHOCK ABSORBER	4614223 € 430,00	4614223 € 430,00	4614223 € 430,00	-
	RS24/10-R FRONT + REAR	-	-	-	-

56 - IF ASSEMBLED WITH CRANKSHAFTS 5313275 (5312810-5316048), USE 2015832 € 40,17

59 - ELECTRIC STARTER IS CUT OUT

66 - NOT to be used on VEHICLE WITH ORIGINAL PRIMARY GEARS



Scooter 50

with ENGINE

DERBI
GILERA

GP1 OPEN

GP1 REVOLUTION

DNA

EASY MOVING

		50 2T	LC	50 2T	LC	50 2T	LC	50 2T		
! TEAM Cylinder and crankshaft MUST BE INSTALLED AS A WHOLE										
	CYLINDER+HEAD	Ø 40 (pin)	31 8865	€ 213,72 (12)	31 8865	€ 213,72 (12)	31 8865	€ 213,72 (12)	31 8862	€ 174,92 (12)
	CYLINDER+HEAD	Ø 47-47,6 (pin)	31 8455	€ 301,54 Ø 47,6 (12)	31 8455	€ 301,54 Ø 47,6 (12)	31 8455	€ 301,54 Ø 47,6 (12)	31 8398	€ 267,15 Ø 47,6 (12)
	CYLINDER+HEAD	Ø 47,6 (pin)	3111584	€ 324,71 (12)	3111584	€ 324,71 (12)	3111584	€ 324,71 (12)	-	-
	CRANKSHAFTS RHQ	PIN Ø 12	53 7600	€ 175,50	53 7600	€ 175,50	53 7600	€ 175,50	53 7600	€ 175,50
	CYLINDER+HEAD	Ø 40	31 8884	€ 284,08	31 8884	€ 284,08	31 8884	€ 284,08	31 8881	*38*
	TEAM									€ 181,70
	CYLINDER+HEAD	Ø 47,6	3115142	€ 376,00	3115142	€ 376,00	3115142	€ 376,00	-	-
	TEAM - TEAM 2	STROKE 39 mm C.ROD 80 - 85								
	CYLINDER+HEAD	Ø 50	3113030	€ 367,50	3113030	€ 367,50	3113030	€ 367,50	-	-
	BIG BORE	STROKE 39 mm C.ROD 85								
	CRANKSHAFTS RHQ	PIN Ø 12	53 9212	€ 285,15	53 9212	€ 285,15	53 9212	€ 285,15	53 9212	€ 285,15
	CRANKSHAFTS RHQ	PIN Ø 12 - 13	5316005	*39* € 478,00	5316005	*39* € 478,00	5316005	*39* € 478,00	5316005	*39* € 478,00
	TEAM	STROKE 39 mm C.ROD 85 - 80								
	CYLINDER+HEAD	Ø 50	3113042	€ 367,50	3113042	€ 367,50	3113042	€ 367,50	-	-
	BIG BORE	STROKE 44 mm C.ROD 85								
	CRANKSHAFTS RHQ	PIN Ø 13	5313270	*73* € 450,00	5313270	*73* € 450,00	5313270	*73* € 450,00	-	-
	BIG BORE	STROKE 44 mm C.ROD 85								
	CYLINDER+HEAD	Ø 52	3115385	€ 430,00	3115385	€ 430,00	3115385	€ 430,00	-	-
	BIG BORE testa rossa	STROKE 44 mm C.ROD 90								
	CRANKSHAFTS RHQ	PIN Ø 13	5316029	€ 465,00	5316029	€ 465,00	5316029	€ 465,00	-	-
	TEAM	STROKE 44 mm C.ROD 90								
	RADIAL ROLLER BEARING	pg. 473	6614105EA	€ 82,00	6614105EA	€ 82,00	6614105EA	€ 82,00	6614105EA	€ 82,00
	EXHAUST SYSTEM SCOOTER RACING	Ø 40	-	-	-	-	-	-	-	-
	EXHAUST SYSTEM SCOOTER RACING	Ø 47 - 47,6	32 9027	€ 314,23	3212965	€ 377,20	32 9027	€ 314,23	32 9834	€ 377,08
	EXHAUST SYSTEM SCOOTER RACING	Ø 47,6	-	-	-	-	-	-	-	-
	TEAM 2									
	EXHAUST SYSTEM SCOOTER RACING	Ø 47,6	3215341	€ 366,18	3215341	€ 366,18	3215341	€ 366,18	-	-
	TEAM 3									
	EXHAUST SYSTEM SCOOTER RACING	Ø 50	3215134	€ 366,18	3215134	€ 366,18	3215134	€ 366,18	-	-
	BIG BORE 2 Ø 50	STROKE 39 - 44 mm								
	EXHAUST SYSTEM SCOOTER RACING	Ø 52	3216158	€ 366,18	3216158	€ 366,18	3216158	€ 366,18	-	-
	BIG BORE Ø 52	STROKE 44 mm								
	CARBURETTOR KIT	PHBG Ø 19	1611023	€ 132,14	1611023	€ 132,14	1611023	€ 132,14	1611021	€ 129,40
	TEAM									
	PHBG Ø 19		1611021.T	€ 202,60	1611021.T	€ 202,60	1611021.T	€ 202,60	1611021.T	€ 202,60
	PHBG Ø 21		1613890.TO	€ 210,60	1613890.TO	€ 210,60	1613890.TO	€ 210,60	1613890.TO	€ 210,60
	PHBL Ø 25		1611009	€ 217,99	1611009	€ 217,99	1611009	€ 217,99	-	-
	VHST Ø 28		1613766	€ 251,86	1613766	€ 251,86	1613766	€ 251,86	1613766	€ 251,86
	INTAKE MANIFOLDS	Ø 22 x 24,5 RUBBER NBR	02 8732B	€ 52,50	02 8732B	€ 52,50	02 8732B	€ 52,50	02 8732B	€ 52,50
	RUBBER FKM		02 9732B	€ 65,10	02 9732B	€ 65,10	02 9732B	€ 65,10	02 9732B	€ 65,10
	INTAKE MANIFOLDS	Ø 22 x 28 RUBBER NBR	02 8856B	€ 52,50	02 8856B	€ 52,50	02 8856B	€ 52,50	02 8856B	€ 52,50
	RUBBER FKM		02 9441B	€ 65,10	02 9441B	€ 65,10	02 9441B	€ 65,10	02 9441B	€ 65,10
	INTAKE MANIFOLDS X360	Ø 22 x 24,5 RUBBER FKM	2014520	€ 52,02	2014520	€ 52,02	2014520	€ 52,02	2014520	€ 52,02
	RUBBER FKM		2014519	€ 52,02	2014519	€ 52,02	2014519	€ 52,02	2014519	€ 52,02
	RUBBER FKM	Ø 22 x 28								
	RUBBER FKM	Ø 30 x 35	2013802	€ 52,02	2013802	€ 52,02	2013802	€ 52,02	2013802	€ 52,02
	REED VALVE	CARBON FIBRE	27 9490.CO	€ 52,25 VL13	27 9490.CO	€ 52,25 VL13	27 9490.CO	€ 52,25 VL13	27 9490.CO	€ 52,25 VL13
	REED VALVE	CARBON FIBRE	2713719.CO	*19* € 57,68 VL16	2713719.CO	*19* € 57,68 VL16	2713719.CO	*19* € 57,68 VL16	2713719.CO	*19* € 57,68 VL16
	DIGITRONIC EPROM		55 9002	€ 189,75	55 9002	€ 189,75	55 9002	€ 189,75	55 9002	€ 189,75
	ELECTRONIC DIGITAL CONTROLLER									
	INNER ROTOR IGNITION		5514691	€ 328,50	5514691	€ 328,50	5514691	€ 328,50	5514689	€ 318,50
	INNER ROTOR IGNITION	TEAM	5515001	€ 350,00	5515001	€ 350,00	5515001	€ 350,00	5515001	€ 350,00

19 - for the ASSEMBLY MODIFY the CRANKCASE

38 - IT IS NOT MODULAR-head

39 - WE SUGGEST TO USE bearings : 6614105EA € 82,00

73 - Crankcase MODIFICATIONS: BORING - WE SUGGEST TO USE bearings 6614105EA

GILERA

ICE		RUNNER		RUNNER SP <-2005		RUNNER SP 2006->		STALKER		STORM		TYPHOON		TYPHOON X	
						(C451M)									
50 2T	☼	50 2T	LC	50 2T	LC	50 2T	LC	50 2T	☼	50 2T	☼	50 2T	☼	50 2T	☼
31 8862	€ 174,92 (12)	31 8865	€ 213,72 (12)	31 8865	€ 213,72 (12)	31 8865	€ 213,72 (12)	31 8862	€ 174,92 (12)	31 8862	€ 174,92 (12)	31 8862	€ 174,92 (12)	31 8862	€ 174,92 (12)
31 8398	€ 267,15 Ø 47,6 (12)	31 8455	€ 301,54 Ø 47,6 (12)	31 8455	€ 301,54 Ø 47,6 (12)	31 8455	€ 301,54 Ø 47,6 (12)	31 8398	€ 267,15 Ø 47,6 (12)	31 8398	€ 267,15 Ø 47,6 (12)	31 8398	€ 267,15 Ø 47,6 (12)	31 8398	€ 267,15 Ø 47,6 (12)
-		3111584	€ 324,71 (12)	3111584	€ 324,71 (12)	3111584	€ 324,71 (12)	-		-		-		-	
53 7600	€ 175,50	53 7600	€ 175,50	53 7600	€ 175,50	53 7600	€ 175,50	53 7600	€ 175,50	53 7600	€ 175,50	53 7600	€ 175,50	53 7600	€ 175,50
31 8881 *38*	€ 181,70	31 8884	€ 284,08	31 8884	€ 284,08	31 8884	€ 284,08	31 8881 *38*	€ 181,70	31 8881 *38*	€ 181,70	31 8881 *38*	€ 181,70	31 8881 *38*	€ 181,70
-		3115142	€ 376,00	3115142	€ 376,00	3115142	€ 376,00	-		-		-		-	
-		3113030	€ 367,50	3113030	€ 367,50	3113030	€ 367,50	-		-		-		-	
53 9212	€ 285,15	53 9212	€ 285,15	53 9212	€ 285,15	53 9212	€ 285,15	53 9212	€ 285,15	53 9212	€ 285,15	53 9212	€ 285,15	53 9212	€ 285,15
5316005 *39*	€ 478,00	5316005 *39*	€ 478,00	5316005 *39*	€ 478,00	5316005 *39*	€ 478,00	5316005 *39*	€ 478,00	5316005 *39*	€ 478,00	5316005 *39*	€ 478,00	5316005 *39*	€ 478,00
-		3113042	€ 367,50	3113042	€ 367,50	3113042	€ 367,50	-		-		-		-	
-		5313270 *73*	€ 450,00	5313270 *73*	€ 450,00	5313270 *73*	€ 450,00	-		-		-		-	
-		3115385	€ 430,00	3115385	€ 430,00	3115385	€ 430,00	-		-		-		-	
-		5316029	€ 465,00	5316029	€ 465,00	5316029	€ 465,00	-		-		-		-	
6614105EA	€ 82,00	6614105EA	€ 82,00	6614105EA	€ 82,00	6614105EA	€ 82,00	6614105EA	€ 82,00	6614105EA	€ 82,00	6614105EA	€ 82,00	6614105EA	€ 82,00
-		-		-		-		-		-		-		-	
32 9027	€ 314,23	32 9027	€ 314,23	32 9027	€ 314,23	32 9027	€ 314,23	32 9027	€ 314,23	32 9027	€ 314,23	32 9027	€ 314,23	32 9027	€ 314,23
-		-		-		-		-		-		-		-	
-		3215341	€ 366,18	3215341	€ 366,18	3215341	€ 366,18	-		-		-		-	
-		3215134	€ 366,18	3215134	€ 366,18	3215134	€ 366,18	-		-		-		-	
-		3216158	€ 366,18	3216158	€ 366,18	3216158	€ 366,18	-		-		-		-	
1611021	€ 129,40	1611023	€ 132,14	1611023	€ 132,14	1611023	€ 132,14	1611021	€ 129,40	1611021	€ 129,40	1611021	€ 129,40	1611021	€ 129,40
1611021.T	€ 202,60	1611021.T	€ 202,60	1611021.T	€ 202,60	1611021.T	€ 202,60	1611021.T	€ 202,60	1611021.T	€ 202,60	1611021.T	€ 202,60	1611021.T	€ 202,60
1613890.TO	€ 210,60	1613890.TO	€ 210,60	1613890.TO	€ 210,60	1613890.TO	€ 210,60	1613890.TO	€ 210,60	1613890.TO	€ 210,60	1613890.TO	€ 210,60	1613890.TO	€ 210,60
1611009	€ 217,99	1611009	€ 217,99	1611009	€ 217,99	1611009	€ 217,99	1611009	€ 217,99	1611009	€ 217,99	1611009	€ 217,99	1611009	€ 217,99
1613766	€ 251,86	1613766	€ 251,86	1613766	€ 251,86	1613766	€ 251,86	1613766	€ 251,86	1613766	€ 251,86	1613766	€ 251,86	1613766	€ 251,86
02 8732B	€ 52,50	02 8732B	€ 52,50	02 8732B	€ 52,50	02 8732B	€ 52,50	02 8732B	€ 52,50	02 8732B	€ 52,50	02 8732B	€ 52,50	02 8732B	€ 52,50
02 9732B	€ 65,10	02 9732B	€ 65,10	02 9732B	€ 65,10	02 9732B	€ 65,10	02 9732B	€ 65,10	02 9732B	€ 65,10	02 9732B	€ 65,10	02 9732B	€ 65,10
02 8856B	€ 52,50	02 8856B	€ 52,50	02 8856B	€ 52,50	02 8856B	€ 52,50	02 8856B	€ 52,50	02 8856B	€ 52,50	02 8856B	€ 52,50	02 8856B	€ 52,50
02 9441B	€ 65,10	02 9441B	€ 65,10	02 9441B	€ 65,10	02 9441B	€ 65,10	02 9441B	€ 65,10	02 9441B	€ 65,10	02 9441B	€ 65,10	02 9441B	€ 65,10
2014520	€ 52,02	2014520	€ 52,02	2014520	€ 52,02	2014520	€ 52,02	2014520	€ 52,02	2014520	€ 52,02	2014520	€ 52,02	2014520	€ 52,02
2014519	€ 52,02	2014519	€ 52,02	2014519	€ 52,02	2014519	€ 52,02	2014519	€ 52,02	2014519	€ 52,02	2014519	€ 52,02	2014519	€ 52,02
2013802	€ 52,02	2013802	€ 52,02	2013802	€ 52,02	2013802	€ 52,02	2013802	€ 52,02	2013802	€ 52,02	2013802	€ 52,02	2013802	€ 52,02
27 9490.C0	€ 52,25 VL13	27 9490.C0	€ 52,25 VL13	27 9490.C0	€ 52,25 VL13	27 9490.C0	€ 52,25 VL13	27 9490.C0	€ 52,25 VL13	27 9490.C0	€ 52,25 VL13	27 9490.C0	€ 52,25 VL13	27 9490.C0	€ 52,25 VL13
2713719.C0 *19*	€ 57,68 VL16	2713719.C0 *19*	€ 57,68 VL16	2713719.C0 *19*	€ 57,68 VL16	2713719.C0 *19*	€ 57,68 VL16	2713719.C0 *19*	€ 57,68 VL16	2713719.C0 *19*	€ 57,68 VL16	2713719.C0 *19*	€ 57,68 VL16	2713719.C0 *19*	€ 57,68 VL16
55 9002	€ 189,75	55 9002	€ 189,75	55 9002	€ 189,75	55 9002	€ 189,75	55 9002	€ 189,75	55 9002	€ 189,75	55 9002	€ 189,75	55 9002	€ 189,75
5514689	€ 318,50	5514691 € 328,50 5515001 € 350,00	5514691 € 328,50 5515001 € 350,00	5514691 € 328,50 5515001 € 350,00	5514691 € 328,50 5515001 € 350,00	5514689	€ 318,50	5514689	€ 318,50	5514689	€ 318,50	5514689	€ 318,50	5514689	€ 318,50



MHR[®]

MALOSSI HYPER RACING

Scooter 50

with ENGINE 

DERBI

GILERA

GP1 OPEN

GP1 REVOLUTION

DNA

EASY MOVING

50 2T

LC

50 2T















LC

50 2T

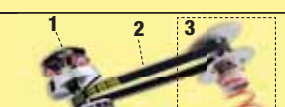
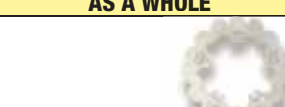
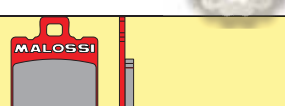
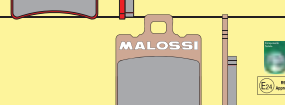
LC

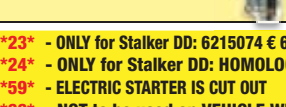
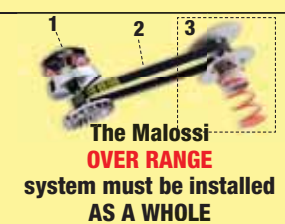
50 2T

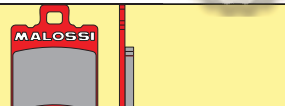

	MULTIVAR VARIATOR	-	-	-	51 8648 € 68,00
	MULTIVAR TEAM VARIATOR	5112645 € 77,25	5112645 € 77,25	5112645 € 77,25	5112645 € 77,25
	X K BELT BELT	6114118 € 38,25	6114118 € 38,25	61 9535 € 28,72	61 7665 € 25,68
	VENTILVAR HALF-PULLEY	6113416B *59* € 36,72	6113416B *59* € 36,72	6113416B *59* € 36,72	6113416B *59* € 36,72
	TORSION CONTROLLER ANTIFRICTION FIFTH WHEEL	2512828 € 4,45	2512828 € 4,45	2512828 € 4,45	2512828 € 4,45
	TORQUE DRIVER MOBILE DRIVEN SPLIT PULLEY	61 9100 € 85,57	61 9100 € 85,57	61 9100 € 85,57	61 8233 € 85,57
	DELTA CLUTCH ADJUSTABLE CLUTCH	52 7880 € 77,89	52 7880 € 77,89	52 7880 € 77,89	52 7880 € 77,89
	WING CLUTCH BELL CLUTCH BELL (FINNED RING)	7714147 € 90,00 Ø 107	7714147 € 90,00 Ø 107	7714147 € 90,00 Ø 107	7714147 € 90,00 Ø 107
	DELTA SYSTEM MHR BELL + ADJUSTABLE CLUTCH	5214738 € 156,00	5214738 € 156,00	5214738 € 156,00	5214738 € 156,00
	ROLLER CRANKCASE GEAR-BOX COVERS	2514521 *66* € 95,00	2514521 *66* € 95,00	-	-
	ROLLER CRANKCASE TEAM GEAR-BOX COVERS	2514603 *66* € 95,00	2514603 *66* € 95,00	-	-
	PINWHEEL SHAFT	6714530 € 66,30	6714530 € 66,30	6714530 € 66,30	-
	GEARS HTQ PRIMARY	-	-	6711602 € 69,34 z 14/48	-
	GEARS HTQ (PIAGGIO) PRIMARY	67 9080 z 14/39 € 60,41 6713339 z 15/38 € 61,71	67 9080 z 14/39 € 60,41 6713339 z 15/38 € 61,71	-	67 8727 € 57,67 z 16/37
	GEARS HTQ SECONDARY	67 9966 € 65,00 z13/48 (17)	-	-	67 7385 € 56,53 z 16/37
	SPLINED COUPLING Ø 17	-	-	-	-
	COUPLING Ø 18	-	-	-	-
	SECOND ROLLER GEAR (COUPLING)	67 9967 € 71,36 z 13/48 (17)	-	-	-
KIT	OVER RANGE / OVER RANGE ALUMINUM	6114219 € 262,65 6115781 € 365,00	6114219 € 262,65 6115781 € 365,00	-	6114215 € 253,98
	1 MULTIVAR / ALUMINUM VARIATOR	5112645 € 77,25 5115644 € 87,55	5112645 € 77,25 5115644 € 87,55	-	5112645 € 77,25
The Malossi OVER RANGE system must be installed AS A WHOLE	2 X K BELT BELT	6114118 € 38,25	6114118 € 38,25	-	-
	2 X K BELT TEAM / ALUMINUM	6115668 € 44,88	6115668 € 44,88	-	6114114 € 38,76
	3 REAR PULLEY SYSTEM / ALUMINUM REAR PULLEY	6113101 € 174,40 6114582 € 275,31	6113101 € 174,40 6114582 € 275,31	6113101 € 174,40	6112110 € 163,82
	WHOOB DISC FRONT BRAKE DISC	-	-	6212351 € 88,30 2000->	6214097 € 62,00 1995->
	WHOOB DISC REAR BRAKE DISC	-	-	6212604 € 76,38 2000->	-
	BRAKE PADS MHR ORGANIC BRAKE PADS	FRONT	-	-	6215080 € 6,00 1995->
	BRAKE PADS MHR SYNT SINTERED BRAKE PADS	FRONT	-	6215017 € 15,00	6215011 € 16,00 2000-> 6215007 € 11,96 1995->
	BRAKE PADS MHR ORGANIC BRAKE PADS	REAR	-	6215076 € 6,24	-
	BRAKE PADS MHR SYNT SINTERED BRAKE PADS	REAR	-	6215005 € 11,96	6215015 € 16,64 2000->
	RADIATOR / RADIATOR TEAM	-	-	7111680 € 218,82	-
	RS24/10 - RS24/10-R FRONT SHOCK ABSORBER	-	-	-	-
	RS24/10 - RS24/10-R REAR SHOCK ABSORBER	-	-	-	4614237 € 428,82
	RS24/10-R FRONT + REAR	-	-	-	-

23 - ONLY for Stalker DD: 6215074 € 6,30

24 - ONLY for Stalker DD: HOMOLOGATED 6215006 € 11,96

59 - ELECTRIC STARTER IS CUT OUT

66 - NOT to be used on VEHICLE WITH ORIGINAL PRIMARY GEARS

GILERA

GILERA							
ICE	RUNNER	RUNNER SP <-2005	RUNNER SP 2006->	STALKER	STORM	TYPHOON	TYPHOON X
			(C451M)				
50 2T	50 2T LC	50 2T LC	50 2T LC	50 2T	50 2T	50 2T	50 2T
51 9203 € 68,00 (1997)	-	-	-	-	51 8648 € 68,00	51 8648 € 68,00	-
5112645 € 77,25	5112645 € 77,25	5112645 € 77,25	5112645 € 77,25	5112645 € 77,25	5112645 € 77,25	5112645 € 77,25	5112645 € 77,25
6114118 € 38,25	6114118 € 38,25	6114118 € 38,25	6114118 € 38,25	6114118 € 38,25	61 7587 € 28,25 6114118 € 38,25	61 7587 € 28,25 6114118 € 38,25	6114118 € 38,25
6113416B *59* € 36,72	6113416B *59* € 36,72	6113416B *59* € 36,72	6113416B *59* € 36,72	6113416B *59* € 36,72	6113416B *59* € 36,72	6113416B *59* € 36,72	6113416B *59* € 36,72
2512828 € 4,45	2512828 € 4,45	2512828 € 4,45	2512828 € 4,45	2512828 € 4,45	2512828 € 4,45	2512828 € 4,45	2512828 € 4,45
61 9100 € 85,57	61 9100 € 85,57	61 9100 € 85,57	61 9100 € 85,57	61 9100 € 85,57	61 8233 € 85,57	61 8233 € 85,57	61 9100 € 85,57
52 7880 € 77,89	52 7880 € 77,89	52 7880 € 77,89	52 7880 € 77,89	52 7880 € 77,89	52 7880 € 77,89	52 7880 € 77,89	52 7880 € 77,89
7714147 € 90,00 Ø 107	7714147 € 90,00 Ø 107	7714147 € 90,00 Ø 107	7714147 € 90,00 Ø 107	7714147 € 90,00 Ø 107	7714147 € 90,00 Ø 107	7714147 € 90,00 Ø 107	7714147 € 90,00 Ø 107
5214738 € 156,00	5214738 € 156,00	5214738 € 156,00	5214738 € 156,00	5214738 € 156,00	5214738 € 156,00	5214738 € 156,00	5214738 € 156,00
2514521 *66* € 95,00	2514521 *66* € 95,00	2514521 *66* € 95,00	2514521 *66* € 95,00	2514521 *66* € 95,00	-	-	2514521 *66* € 95,00
2514603 *66* € 95,00	2514603 *66* € 95,00	2514603 *66* € 95,00	2514603 *66* € 95,00	2514603 *66* € 95,00	-	-	2514603 *66* € 95,00
6714530 € 66,30	6714530 € 66,30	6714530 € 66,30	6714530 € 66,30	6714530 € 66,30	-	-	6714530 € 66,30
-	-	-	-	-	-	-	-
67 9080 z 14/39 € 60,41 6713339 z 15/38 € 61,71	67 9080 z 14/39 € 60,41 6713339 z 15/38 € 61,71	67 9080 z 14/39 € 60,41 6713339 z 15/38 € 61,71	67 9080 z 14/39 € 60,41 6713339 z 15/38 € 61,71	67 9080 z 14/39 € 60,41 6713339 z 15/38 € 61,71	67 8220 € 56,53 z 14/39	67 8220 € 56,53 z 14/39	67 9080 z 14/39 € 60,41 6713339 z 15/38 € 61,71
-	-	-	-	-	67 8218 € 56,53 z 14/39	67 8218 € 56,53 z 14/39	-
67 9966 € 65,00 z 13/48	67 9966 *PG* € 65,00 z 13/48	67 9966 *PG* € 65,00 z 13/48	67 9966 € 65,00 z 13/48	67 9966 *PG* € 65,00 z 13/48	-	-	67 9966 *PG* € 65,00 z 13/48
-	67 8938 *PG* € 60,41 z 13/48	67 8938 *PG* € 60,41 z 13/48	-	67 8938 *PG* € 60,41 z 13/48	67 8938 *PG* € 60,41 z 13/48	67 8938 *PG* € 60,41 z 13/48	-
-	-	-	-	-	-	-	-
67 9967 € 71,36 z 13/48 (17)	67 9967 *PG* € 71,36 z 13/48 (17)	67 9967 *PG* € 71,36 z 13/48 (17)	67 9967 € 71,36 z 13/48 (17)	67 9967 *PG* € 71,36 z 13/48 (17)	67 8714 *PG* € 63,98 z 13/48 (18)	67 8714 *PG* € 63,98 z 13/48 (18)	67 9967 *PG* € 71,36 z 13/48 (17)
6114219 € 262,65 6115781 € 365,00	6114219 € 262,65 6115781 € 365,00	6114219 € 262,65 6115781 € 365,00	6114219 € 262,65 6115781 € 365,00	6114219 € 262,65 6115781 € 365,00	6114216 € 251,48	6114216 € 251,48	6114219 € 262,65 6115781 € 365,00
5112645 € 77,25 5115644 € 87,55	5112645 € 77,25 5115644 € 87,55	5112645 € 77,25 5115644 € 87,55	5112645 € 77,25 5115644 € 87,55	5112645 € 77,25 5115644 € 87,55	5112645 € 77,25	5112645 € 77,25	5112645 € 77,25 5115644 € 87,55
6114118 € 38,25	6114118 € 38,25	6114118 € 38,25	6114118 € 38,25	6114118 € 38,25	6114118 € 38,25	6114118 € 38,25	6114118 € 38,25
6115668 € 44,88	6115668 € 44,88	6115668 € 44,88	6115668 € 44,88	6115668 € 44,88	-	-	6115668 € 44,88
6113101 € 174,40 6114582 € 275,31	6113101 € 174,40 6114582 € 275,31	6113101 € 174,40 6114582 € 275,31	6113101 € 174,40 6114582 € 275,31	6113101 € 174,40 6114582 € 275,31	6112110 € 163,82	6112110 € 163,82	6113101 € 174,40 6114582 € 275,31
-	6212929 € 105,00 1997->	6212929 € 105,00 1998->99	-	6212603 € 72,56 1997->	6212603 € 72,56 1994->	6212603 € 72,56 1993->	6212603 € 72,56 1993->
-	-	-	-	-	-	-	-
6215080 € 6,00 2000->	6215080 € 6,00 1997->	6215080 € 6,00 1998->99	6215079 € 8,20	6215080 € 6,00 1997->	6215080 € 6,00 1994->	6215080 € 6,00 1993->	6215080 € 6,00 1993->
6215007 € 11,96 2000->	6215007 € 11,96 1997->	6215011 2000-> € 16,00 6215007 1998->99 € 11,96	6215013 € 16,50	6215007 € 11,96 1997->	6215007 € 11,96 1994->	6215007 € 11,96 1993->	6215007 € 11,96 1993->
-	-	6215074 € 6,30 1998->	6215074 € 6,30	-	-	-	-
-	-	6215006 € 11,96 1998->	6215006 € 11,96	*23*	-	-	-
-	71 9786 € 214,59	71 9786 € 214,59	-	-	-	-	-
-	-	-	-	-	-	-	-
-	4614237 € 428,82	4614237 € 428,82	4614237 € 428,82	-	4614237 € 428,82	-	-
-	-	-	-	-	-	-	-

PG - SPECIFICATIONS on the PAGE indicated in the TITLE of the LINE



Scooter 50

with ENGINE

HONDA

DIO G

DIO SP

DIO SR

DIO ZX
<-1993

50 2T



50 2T



50 2T



50 2T



TEAM Cylinder and crankshaft MUST BE INSTALLED AS A WHOLE

	CYLINDER+HEAD	Ø 40 (pin)	-	-	-	-
	CYLINDER+HEAD	Ø 47-47,6 (pin)	-	-	-	-
	CYLINDER+HEAD	Ø 47,6 (pin)	-	-	-	-
	TEAM Replica	Ø 47,6 (pin)	-	-	-	-
	CRANKSHAFTS RHQ	PIN Ø 12	53 7814	53 7814	53 7814	53 7604
		STROKE 39 mm CONNECTING ROD 80	€ 188,00	€ 188,00	€ 188,00	€ 185,00
	CYLINDER+HEAD	Ø 40	-	-	-	-
	TEAM	Ø 47,6	-	-	-	-
	CYLINDER+HEAD	Ø 47,6	-	-	-	-
	TEAM - TEAM 2	STROKE 39 mm C.ROD 80 - 85	-	-	-	-
	CYLINDER+HEAD	Ø 50	-	-	-	-
	BIG BORE	STROKE 39 mm C.ROD 85	-	-	-	-
	CRANKSHAFTS RHQ	PIN Ø 12	-	-	-	-
		STROKE 39 mm C.ROD 85 - 80	-	-	-	-
	CRANKSHAFTS RHQ	PIN Ø 12 - 13	-	-	-	-
	TEAM	STROKE 39 mm C.ROD 85 - 80	-	-	-	-
	CYLINDER+HEAD	Ø 50	-	-	-	-
	BIG BORE	STROKE 44 mm C.ROD 85	-	-	-	-
	CRANKSHAFTS RHQ	PIN Ø 13	-	-	-	-
	BIG BORE	STROKE 44 mm C.ROD 85	-	-	-	-
	CYLINDER+HEAD	Ø 52	-	-	-	-
	BIG BORE testa rossa	STROKE 44 mm C.ROD 90	-	-	-	-
	CRANKSHAFTS RHQ	PIN Ø 13	-	-	-	-
	TEAM	STROKE 44 mm C.ROD 90	-	-	-	-
	RADIAL ROLLER BEARING	Ø 40	-	-	-	-
	EXHAUST SYSTEM SCOOTER RACING	Ø 40	-	-	-	-
	EXHAUST SYSTEM SCOOTER RACING	Ø 47 - 47,6	-	-	-	-
	EXHAUST SYSTEM SCOOTER RACING	Ø 47,6	-	-	-	-
	TEAM 2	Ø 47,6	-	-	-	-
	EXHAUST SYSTEM SCOOTER RACING	Ø 47,6	-	-	-	-
	TEAM 3	Ø 50	-	-	-	-
	EXHAUST SYSTEM SCOOTER RACING	Ø 50	-	-	-	-
	BIG BORE 2 Ø 50	STROKE 39 - 44 mm	-	-	-	-
EXHAUST SYSTEM SCOOTER RACING	Ø 52	-	-	-	-	
	BIG BORE Ø 52	STROKE 44 mm	-	-	-	-
	CARBURETTOR KIT	PHBG Ø 19	1611010	1611010	1611010	1611010
		PHBG Ø 19	€ 179,16 BIG pipe	€ 179,16 BIG pipe	€ 179,16 BIG pipe	€ 179,16 BIG pipe
	TEAM	PHBG Ø 21	-	-	-	-
	TEAM	PHBG Ø 25	-	-	-	-
	PHBL Ø 25	1611008	1611008	1611008	1611008	
		€ 216,64	€ 216,64	€ 216,64	€ 216,64	
	VHST Ø 28	TEAM	-	-	-	-
	INTAKE MANIFOLDS	Ø 22 x 24,5 RUBBER NBR	-	-	-	-
		RUBBER FKM	-	-	-	-
	INTAKE MANIFOLDS	Ø 22 x 28 RUBBER NBR	-	-	-	-
		RUBBER FKM	-	-	-	-
	INTAKE MANIFOLDS X360	Ø 22 x 24,5 RUBBER FKM	-	-	-	-
		Ø 22 x 28 RUBBER FKM	-	-	-	-
		Ø 30 x 35 RUBBER FKM	-	-	-	-
	REED VALVE	CARBON FIBRE	-	-	-	-
	REED VALVE	CARBON FIBRE	-	-	-	-
	TEAM		-	-	-	-
	DIGITRONIC EPROM	ELECTRONIC DIGITAL CONTROLLER	-	-	-	-
	INNER ROTOR IGNITION	INNER ROTOR IGNITION	-	-	-	-
	TEAM		-	-	-	-

19 - for the ASSEMBLY MODIFY the CRANKCASE

21 - ONLY for vehicles WITH Malossi MULTIVAR AND PISTON WITH PIN Ø 12

79 - Crankcase MODIFICATIONS: BORING - TO COUPLE ONLY with Multivar 5112800 or 5115823

ITALJET		KYMCO		MALAGUTI			
DRAGSTER	TORPEDO NEW	DJ X	DJ Y	F10	F12-PHANTOM	F12-PHANTOM	F12 DIGIT KAT-PHANTOM
50 2T	LC	50 2T	50 2T	50 2T	50 2T	50 2T	50 2T
31 8559 € 209,16 (10)	-	-	-	31 8403 € 184,06 (10)	31 8403 € 184,06 (10)	31 8559 € 209,16 (10)	31 8559 € 209,16 (10)
31 8460 € 301,54 Ø 47,6 (12)	-	-	-	31 8440 € 267,15 Ø 47,6 (12)	31 8440 € 267,15 Ø 47,6 (12)	31 8460 € 301,54 Ø 47,6 (12)	31 8460 € 301,54 Ø 47,6 (12)
-	-	-	-	-	-	-	-
53 8009 € 175,50	53 7600 € 175,50	-	53 7604 € 185,00	53 8009 € 175,50	53 8009 € 175,50	53 8009 € 175,50	53 8009 € 175,50
3111511 € 302,14	-	-	-	-	-	3111511 € 302,14	3111511 € 302,14
3112642 € 357,72	-	-	-	-	-	3112642 € 357,72	3112642 € 357,72
-	-	-	-	-	-	-	-
53 8855 € 177,14 53 8009 € 175,50	-	-	-	-	-	53 8855 € 177,14 53 8009 € 175,50	53 8855 € 177,14 53 8009 € 175,50
5315973 € 480,00 5314548 € 465,00	-	-	-	-	-	5315973 € 480,00 5314548 € 465,00	5315973 € 480,00 5314548 € 465,00
-	-	-	-	-	-	-	-
5313275 *79* € 450,00	-	-	-	-	-	5313275 *79* € 450,00	5313275 *79* € 450,00
3115374 € 430,00	-	-	-	-	-	3115374 € 430,00	3115374 € 430,00
5316039 *79* € 465,00	-	-	-	-	-	5316039 *79* € 465,00	5316039 *79* € 465,00
PG.473	-	-	-	PG.473	PG.473	PG.473	PG.473
3212825 € 308,06 DISMANTLED	-	-	-	-	-	3212825 € 308,06 DISMANTLED	3212825 € 308,06 DISMANTLED
-	-	-	-	32 7562 € 266,00	-	-	-
-	-	-	-	3214763 € 366,18	3214763 € 366,18	3214763 € 366,18	3214763 € 366,18
-	-	-	-	-	-	-	-
3215198 € 366,18	-	-	-	-	-	3215198 € 366,18	3215198 € 366,18
3216827 € 366,18	-	-	-	-	-	3216827 € 366,18	3216827 € 366,18
1611021 € 129,40	-	1611010 € 179,16 BIG pipe	1611010 € 179,16 BIG pipe	1611021 € 129,40	1611021 € 129,40	1611021 € 129,40	1611021 € 129,40
1611021.T € 202,60	-	-	-	-	-	1611021.T € 202,60	1611021.T € 202,60
1613890.TO € 210,60	-	-	-	-	-	1613890.TO € 210,60	1613890.TO € 210,60
1611013 € 217,38	-	1611008 € 216,64	1611008 € 216,64	1611013 € 217,38	1611013 € 217,38	1611013 € 217,38	1611013 € 217,38
1614022 € 251,86	-	-	-	1614022 € 251,86	1614022 € 251,86	1614022 € 251,86	1614022 € 251,86
0213222B € 52,50	02 8732B € 52,50	-	-	0213222B € 52,50	0213222B € 52,50	0213222B € 52,50	0213222B € 52,50
0213661B € 65,10	02 9732B € 65,10	-	-	0213661B € 65,10	0213661B € 65,10	0213661B € 65,10	0213661B € 65,10
02 8857B € 52,50	-	-	-	02 8857B € 52,50	02 8857B € 52,50	02 8857B € 52,50	02 8857B € 52,50
0213662B € 65,10	-	-	-	0213662B € 65,10	0213662B € 65,10	0213662B € 65,10	0213662B € 65,10
2014524 € 52,02	-	-	-	2014524 € 52,02	2014524 € 52,02	2014524 € 52,02	2014524 € 52,02
2014525 € 52,02	-	-	-	2014525 € 52,02	2014525 € 52,02	2014525 € 52,02	2014525 € 52,02
2013847 € 52,02	-	-	-	2013847 € 52,02	2013847 € 52,02	2013847 € 52,02	2013847 € 52,02
2711817.C0 € 52,25 VL14	27 9490.C0 € 52,25 VL13	-	-	2711817.C0 € 52,25 VL14	2711817.C0 € 52,25 VL14	2711817.C0 € 52,25 VL14	2711817.C0 € 52,25 VL14
-	2713719.C0 *19* € 57,68 VL16	-	-	-	-	-	-
-	-	-	-	-	-	-	-
5514690 € 328,50 5515002 € 350,00	-	-	-	5514690 € 328,50 5515002 € 350,00	5514690 € 328,50 5515002 € 350,00	5514690 € 328,50 5515002 € 350,00	5514690 € 328,50 5515002 € 350,00



Scooter 50

with ENGINE

HONDA

DIO G

DIO SP

DIO SR

DIO ZX
<-1993

50 2T



50 2T



50 2T



50 2T



	MULTIVAR VARIATOR	51 7072 € 58,71	51 7073 € 58,71	51 7073 € 58,71	51 7484 € 58,71
	MULTIVAR TEAM VARIATOR	-	-	-	-
	X K BELT BELT	61 7211 € 25,68	61 7215 € 23,50	61 7215 € 23,50	61 7211 € 25,68
	VENTILVAR HALF-PULLEY	-	-	-	-
	TORSION CONTROLLER ANTIFRICTION FIFTH WHEEL	2512828 € 4,45	2512828 € 4,45	2512828 € 4,45	2512828 € 4,45
	TORQUE DRIVER MOBILE DRIVEN SPLIT PULLEY	61 8317 € 95,61	-	-	61 8317 € 95,61
	DELTA CLUTCH ADJUSTABLE CLUTCH	52 7880 € 77,89	-	-	52 7880 € 77,89
	WING CLUTCH BELL CLUTCH BELL (FINNED RING)	-	-	-	-
	DELTA SYSTEM MHR BELL + ADJUSTABLE CLUTCH	-	-	-	-
	ROLLER CRANKCASE GEAR-BOX COVERS	-	-	-	-
	ROLLER CRANKCASE TEAM GEAR-BOX COVERS	-	-	-	-
	PINWHEEL SHAFT	-	-	-	-
	GEARS HTQ PRIMARY	-	-	-	-
	GEARS HTQ (PIAGGIO) PRIMARY COUPLING Ø 17	-	-	-	-
	COUPLING Ø 18	-	-	-	-
	GEARS HTQ SECONDARY PRESSED COUPLING Ø 17	-	-	-	-
	PG. 478 SPLINED COUPLING Ø 17	-	-	-	-
	COUPLING Ø 18	-	-	-	-
	SECOND ROLLER GEAR (COUPLING)	-	-	-	-
KIT	OVER RANGE / OVER RANGE ALUMINUM	-	-	-	-
	1 MULTIVAR / ALUMINUM VARIATOR	-	-	-	-
	2 X K BELT BELT	-	-	-	-
	2 X K BELT TEAM / ALUMINUM	-	-	-	-
	3 REAR PULLEY SYSTEM / ALUMINUM REAR PULLEY	-	-	-	-
	WHOOOP DISC FRONT BRAKE DISC	62 8960 € 60,68 1991->	62 8960 € 60,68 1993->	62 8960 € 60,68 1990->	62 8960 € 60,68
	WHOOOP DISC REAR BRAKE DISC	-	-	-	-
	BRAKE PADS MHR FRONT ORGANIC BRAKE PADS	62 9085 € 8,32 1991->	62 9085 € 8,32 1993->	62 9085 € 8,32 1990->	-
	BRAKE PADS MHR SYNT FRONT SINTERED BRAKE PADS	-	-	-	-
	BRAKE PADS MHR REAR ORGANIC BRAKE PADS	-	-	-	-
	BRAKE PADS MHR SYNT REAR SINTERED BRAKE PADS	-	-	-	-
	RADIATOR / RADIATOR TEAM	-	-	-	-
	RS24/10 - RS24/10-R FRONT SHOCK ABSORBER	-	-	-	-
	RS24/10 - RS24/10-R REAR SHOCK ABSORBER	-	-	-	-
	RS24/10-R FRONT + REAR	-	-	-	-

25 - For vehicles with AIRY CRANKCASE

56 - IF ASSEMBLED WITH CRANKSHAFTS 5313275 (5312810-5316048), USE 2015832 € 40,17

59 - ELECTRIC STARTER IS CUT OUT

66 - NOT to be used on VEHICLE WITH ORIGINAL PRIMARY GEARS



MHR[®]









MALOSSI HYPER RACING

Scooter 50

with ENGINE **MALAGUTI**F12 DIGIT KAT-
PHANTOM
euro 2F12 R ARIA
euro 2F12 R LC
euro 2

F15 FIREFOX

(QJ*CMA02C*)

		50 2T	LC	50 2T		50 2T	LC	50 2T	LC
	CYLINDER+HEAD Ø 40 (pin)	31 8559	1 €209,16 (10)	-	-	31 8559	1 €209,16 (10)	31 8559	1 €209,16 (10)
	CYLINDER+HEAD Ø 47-47,6 (pin)	31 8460	-	31 8440	-	31 8460	-	31 8460	-
	CYLINDER+HEAD Ø 47,6 (pin)	-	-	-	-	-	-	-	-
	CRANKSHAFTS RHQ PIN Ø 12 STROKE 39 mm CONNECTING ROD 80	53 8009	*21* €175,50	5313587	-	53 8009	*21* €175,50	53 8009	-
	CYLINDER+HEAD Ø 40 TEAM	3111511	€302,14	-	-	3111511	€302,14	3111511	€302,14
	CYLINDER+HEAD Ø 47,6 TEAM - TEAM 2 STROKE 39 mm C.ROD 80 - 85	3112642	€357,72	-	-	3112642	€357,72	3112642	€357,72
	CYLINDER+HEAD Ø 50 BIG BORE STROKE 39 mm C.ROD 85	-	-	-	-	-	-	-	-
	CRANKSHAFTS RHQ PIN Ø 12 STROKE 39 mm C.ROD 85 - 80	53 8855	€177,14	-	-	53 8855	€177,14	53 8855	€177,14
	CRANKSHAFTS RHQ PIN Ø 12 - 13	53 8009	€175,50	-	-	53 8009	€175,50	53 8009	€175,50
	CRANKSHAFTS RHQ PIN Ø 12 - 13 TEAM STROKE 39 mm C.ROD 85 - 80	5315973	€480,00	-	-	5315973	€480,00	5315973	€480,00
	CYLINDER+HEAD Ø 50 BIG BORE STROKE 44 mm C.ROD 85	-	-	-	-	-	-	-	-
	CRANKSHAFTS RHQ PIN Ø 13 BIG BORE STROKE 44 mm C.ROD 85	5313275	*79* €450,00	-	-	5313275	*79* €450,00	5313275	*79* €450,00
	CYLINDER+HEAD Ø 52 BIG BORE testa rossa STROKE 44 mm C.ROD 90	3115374	€430,00	-	-	3115374	€430,00	3115374	€430,00
	CRANKSHAFTS RHQ PIN Ø 13 TEAM STROKE 44 mm C.ROD 90	5316039	*79* €465,00	-	-	5316039	*79* €465,00	5316039	*79* €465,00
	RADIAL ROLLER BEARING Pg. 473	PG.473	-	PG.473	-	PG.473	-	PG.473	-
	EXHAUST SYSTEM SCOOTER RACING Ø 40	3212825	€308,06 DISMANTLED	-	-	3212825	€308,06 DISMANTLED	-	3212825
	EXHAUST SYSTEM SCOOTER RACING Ø 47 - 47,6	-	-	32 7562	€266,00	-	-	-	-
	EXHAUST SYSTEM SCOOTER RACING Ø 47,6 TEAM 2	3214763	€366,18	3214763	€366,18	3214763	€366,18	3214763	€366,18
	EXHAUST SYSTEM SCOOTER RACING Ø 47,6 TEAM 3	-	-	-	-	-	-	-	-
	EXHAUST SYSTEM SCOOTER RACING Ø 50 BIG BORE 2 Ø 50 STROKE 39 - 44 mm	3215198	€366,18	-	-	3215198	€366,18	3215198	€366,18
	EXHAUST SYSTEM SCOOTER RACING Ø 52 BIG BORE Ø 52 STROKE 44 mm	3216827	€366,18	-	-	3216827	€366,18	3216827	€366,18
		CARBURETTOR KIT PHBG Ø 19	1611021	€129,40	1611021	€129,40	1611021	€129,40	1611021
PHBG Ø 19 TEAM		1611021.T	€202,60	1611021.T	€202,60	1611021.T	€202,60	1611021.T	€202,60
PHBG Ø 21 TEAM		1613890.TO	€210,60	1613890.TO	€210,60	1613890.TO	€210,60	1613890.TO	€210,60
PHBL Ø 25		1611013	€217,38	1611013	€217,38	1611013	€217,38	1611013	€217,38
VHST Ø 28 TEAM		1614022	€251,86	1614022	€251,86	1614022	€251,86	1614022	€251,86
		INTAKE MANIFOLDS Ø 22 x 24,5 RUBBER NBR	0213222B	€52,50	0213222B	€52,50	0213222B	€52,50	0213222B
	RUBBER FKM	0213661B	€65,10	0213661B	€65,10	0213661B	€65,10	0213661B	€65,10
	INTAKE MANIFOLDS Ø 22 x 28 RUBBER NBR	02 8857B	€52,50	02 8857B	€52,50	02 8857B	€52,50	02 8857B	€52,50
	RUBBER FKM	0213662B	€65,10	0213662B	€65,10	0213662B	€65,10	0213662B	€65,10
	INTAKE MANIFOLDS X360 Ø 22 x 24,5 RUBBER FKM	2014524	€52,02	2014524	€52,02	2014524	€52,02	2014524	€52,02
	RUBBER FKM	2014525	€52,02	2014525	€52,02	2014525	€52,02	2014525	€52,02
	Ø 22 x 28 RUBBER FKM	2013847	€52,02	2013847	€52,02	2013847	€52,02	2013847	€52,02
	Ø 30 x 35 RUBBER FKM	-	-	-	-	-	-	-	-
	REED VALVE CARBON FIBRE	2711817.CO	€52,25 VL14	2711817.CO *19*	€52,25 VL14	2711817.CO	€52,25 VL14	2711817.CO	€52,25 VL14
	REED VALVE TEAM	-	-	-	-	-	-	-	-
	DIGITRONIC EPROM ELECTRONIC DIGITAL CONTROLLER	-	-	-	-	-	-	-	-
	INNER ROTOR IGNITION	5514690	€328,50	-	-	5514690	€328,50	5514690	€328,50
INNER ROTOR IGNITION TEAM	5515002	€350,00	-	-	5515002	€350,00	5515002	€350,00	

19 - for the ASSEMBLY MODIFY the CRANKCASE

21 - ONLY for vehicles WITH Malossi MULTIVAR AND PISTON WITH PIN Ø 12

79 - Crankcase MODIFICATIONS: BORING - TO COUPLE ONLY with Multivar 5112800 or 5115823



MHR[®]

MALOSSİ HYPER RACING

Scooter 50

with ENGINE **MALAGUTI**F12 DIGIT KAT-
PHANTOM
euro 2F12 R ARIA
euro 2F12 R LC
euro 2

F15 FIREFOX

(QJ***CMA02C***)

50 2T

LC

50 2T















50 2T

LC

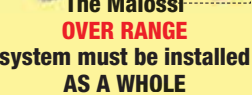
50 2T

LC

	MULTIVAR VARIATOR	5113161 € 78,28	5113363 € 60,00	5113161 € 78,28	5113161 € 78,28
	MULTIVAR TEAM VARIATOR	-	-	-	-
	X K BELT BELT	6112729 € 25,23	61 7587 € 28,25	6112729 € 25,23	6112729 € 25,23
	VENTILVAR HALF-PULLEY	61 7152 € 21,71	61 7151 € 21,28	61 7152 € 21,71	61 7152 € 21,71
	TORSION CONTROLLER ANTIFRICTION FIFTH WHEEL	2512827 € 4,45	-	2512827 € 4,45	2512827 € 4,45
	TORQUE DRIVER MOBILE DRIVEN SPLIT PULLEY	61 8312 (Ø 33) € 85,57 61 9223 (Ø 34) € 85,57	61 8312 € 85,57	61 8312 (Ø 33) € 85,57 61 9223 (Ø 34) € 85,57	61 8312 (Ø 33) € 85,57 61 9223 (Ø 34) € 85,57
	DELTA CLUTCH ADJUSTABLE CLUTCH	52 9451 € 77,89	52 7879 € 77,89	52 9451 € 77,89	52 9451 € 77,89
	WING CLUTCH BELL CLUTCH BELL (FINNED RING)	7714313 € 90,00 Ø 107	-	7714313 € 90,00 Ø 107	7714313 € 90,00 Ø 107
	DELTA SYSTEM MHR BELL + ADJUSTABLE CLUTCH	5214739 € 156,00	-	5214739 € 156,00	5214739 € 156,00
	ROLLER CRANKCASE GEAR-BOX COVERS	2515482 € 95,00	-	2515482 € 95,00	2515482 € 95,00
	ROLLER CRANKCASE TEAM GEAR-BOX COVERS	-	-	-	-
	PINWHEEL SHAFT	6714748 € 60,18	-	6714748 € 60,18	6714748 € 60,18
	GEARS HTQ PRIMARY	6711664 *25* € 56,36 z 13/44	-	6714039 € 57,67 z 13/44	6714039 € 57,67 z 13/44
	GEARS HTQ (PIAGGIO) PRIMARY	-	6713602 € 67,32 z 14/42	-	-
	COUPLING Ø 17	-	-	-	-
	COUPLING Ø 18	-	-	-	-
	GEARS HTQ SECONDARY	6714774 z 15/42 € 67,32 6714775 z 14/43 € 67,32	-	6714774 z 15/42 € 67,32 6714775 z 14/43 € 67,32	6714774 z 15/42 € 67,32 6714775 z 14/43 € 67,32
	PG. 478	-	-	-	-
	SPLINED COUPLING Ø 17	-	-	-	-
	COUPLING Ø 18	-	-	-	-
	SECOND ROLLER GEAR (COUPLING)	-	-	-	-
KIT	OVER RANGE / OVER RANGE ALUMINUM	6112811 € 272,85 6115821 € 365,00	-	6112811 € 272,85 6115821 € 365,00	6112811 € 272,85 6115821 € 365,00
	1 MULTIVAR / ALUMINUM VARIATOR	5112800 € 87,55 5115823 € 88,60 (*56*)	-	5112800 € 87,55 5115823 € 88,60 (*56*)	5112800 € 87,55 5115823 € 88,60 (*56*)
	2 X K BELT BELT	6114116 € 38,25	-	6114116 € 38,25	6114116 € 38,25
	2 X K BELT TEAM / ALUMINUM	6115822 € 44,88	-	6115822 € 44,88	6115822 € 44,88
	3 REAR PULLEY SYSTEM / ALUMINUM REAR PULLEY	61 9733 € 170,82 6114590 € 275,31	-	61 9733 € 170,82 6114590 € 275,31	61 9733 € 170,82 6114590 € 275,31
	WHOO DISC FRONT BRAKE DISC	6212603 € 72,56	6212603 € 72,56	6212603 € 72,56	-
	WHOO DISC REAR BRAKE DISC	-	-	-	-
	BRAKE PADS MHR ORGANIC BRAKE PADS	FRONT 6215080 € 6,00 2000->	6215080 € 6,00	6215080 € 6,00	62 9841 € 6,10 1996->
	BRAKE PADS MHR SYNT SINTERED BRAKE PADS	FRONT 6215007 € 11,96 2000->	6215007 € 11,96	6215007 € 11,96	-
	BRAKE PADS MHR ORGANIC BRAKE PADS	REAR 6215080 € 6,00 2000->	-	6215080 € 6,00	6215080 € 6,00 1998->
	BRAKE PADS MHR SYNT SINTERED BRAKE PADS	REAR 6215007 € 11,96 2000->	-	6215007 € 11,96	6215007 € 11,96 1998->
	RADIATOR / RADIATOR TEAM	-	-	-	-
	RS24/10 - RS24/10-R FRONT SHOCK ABSORBER	-	-	-	-
	RS24/10 - RS24/10-R REAR SHOCK ABSORBER	-	-	-	-
	RS24/10-R FRONT + REAR	-	-	-	-

25 - For vehicles with AIRY CRANKCASE

56 - IF ASSEMBLED WITH CRANKSHAFTS 5313275 (5312810-5316048), USE 2015832 € 40,17



Scooter 50

with ENGINE

MBKBOOSTER SPIRIT
euro 0-1

EVOLIS

FIZZ

FLIPPER

50 2T



50 2T



50 2T



50 2T



TEAM Cylinder and crankshaft MUST BE INSTALLED AS A WHOLE

	CYLINDER+HEAD Ø 40 (pin)	31 8565 1 € 190,84 (10)	31 8403 1 € 184,06 (10)	31 8403 1 € 184,06 (10)	31 8403 1 € 184,06 (10)
	CYLINDER+HEAD Ø 47-47,6 (pin)	31 7559 1 € 251,89 Ø 47 (10)	31 8440 € 267,15 Ø 47,6 (12)	31 8440 € 267,15 Ø 47,6 (12)	31 8440 € 267,15 Ø 47,6 (12)
	CYLINDER+HEAD Ø 47,6 (pin)	-	-	-	-
	TEAM Replica	-	-	-	-
	CRANKSHAFTS RHQ PIN Ø 12 STROKE 39 mm CONNECTING ROD 80	53 8008 € 163,04	53 8009 € 175,50	53 8009 € 175,50	53 8009 € 175,50
	CYLINDER+HEAD Ø 40	-	-	-	-
	TEAM	-	-	-	-
	CYLINDER+HEAD Ø 47,6	-	-	-	-
	TEAM - TEAM 2 STROKE 39 mm C.ROD 80 - 85	-	-	-	-
	CYLINDER+HEAD Ø 50	-	-	-	-
	BIG BORE STROKE 39 mm C.ROD 85	-	-	-	-
	CRANKSHAFTS RHQ PIN Ø 12 STROKE 39 mm C.ROD 85 - 80	-	-	-	-
	CRANKSHAFTS RHQ PIN Ø 12 - 13	-	-	-	-
	TEAM STROKE 39 mm C.ROD 85 - 80	-	-	-	-
	CYLINDER+HEAD Ø 50	-	-	-	-
	BIG BORE STROKE 44 mm C.ROD 85	-	-	-	-
	CRANKSHAFTS RHQ PIN Ø 13	-	-	-	-
	CYLINDER+HEAD Ø 52	-	-	-	-
	BIG BORE testa rossa STROKE 44 mm C.ROD 90	-	-	-	-
	CRANKSHAFTS RHQ PIN Ø 13	-	-	-	-
	TEAM STROKE 44 mm C.ROD 90	-	-	-	-
	RADIAL ROLLER BEARING Pg. 473	PG.473	PG.473	PG.473	PG.473
	EXHAUST SYSTEM SCOOTER RACING Ø 40	-	-	-	-
	EXHAUST SYSTEM SCOOTER RACING Ø 47 - 47,6	32 7561 € 272,00	32 7562 € 266,00	32 7562 € 266,00	32 7562 € 266,00
	EXHAUST SYSTEM SCOOTER RACING Ø 47,6	-	3214763 € 366,18	3214763 € 366,18	3214763 € 366,18
	TEAM 2	-	-	-	-
	EXHAUST SYSTEM SCOOTER RACING Ø 47,6	-	-	-	-
	TEAM 3	-	-	-	-
	EXHAUST SYSTEM SCOOTER RACING Ø 50	-	-	-	-
	BIG BORE 2 Ø 50 STROKE 39 - 44 mm	-	-	-	-
	EXHAUST SYSTEM SCOOTER RACING Ø 52	-	-	-	-
	BIG BORE Ø 52 STROKE 44 mm	-	-	-	-
	CARBURETTOR KIT PHBG Ø 19	1611021 € 129,40	1611021 € 129,40	1611021 € 129,40	1611021 € 129,40
	PHBG Ø 19 TEAM	-	1611021.T € 202,60	1611021.T € 202,60	-
	PHBG Ø 21 TEAM	-	1613890.T0 € 210,60	1613890.T0 € 210,60	-
	PHBL Ø 25	1611011 € 214,11	1611013 € 217,38	1611013 € 217,38	1611013 € 217,38
	VHST Ø 28 TEAM	-	1614022 € 251,86	1614022 € 251,86	1614022 € 251,86
	INTAKE MANIFOLDS Ø 22 x 24,5 RUBBER NBR	-	0213222B € 52,50	0213222B € 52,50	0213222B € 52,50
	RUBBER FKM	-	0213661B € 65,10	0213661B € 65,10	0213661B € 65,10
	INTAKE MANIFOLDS Ø 22 x 28 RUBBER NBR	-	02 8857B € 52,50	02 8857B € 52,50	02 8857B € 52,50
	RUBBER FKM	-	0213662B € 65,10	0213662B € 65,10	0213662B € 65,10
	INTAKE MANIFOLDS X360 Ø 22 x 24,5 RUBBER FKM	-	2014524 € 52,02	2014524 € 52,02	2014524 € 52,02
	Ø 22 x 28 RUBBER FKM	-	2014525 € 52,02	2014525 € 52,02	2014525 € 52,02
	Ø 30 x 35 RUBBER FKM	-	2013847 € 52,02	2013847 € 52,02	2013847 € 52,02
	REED VALVE CARBON FIBRE	27 7441.C0 € 46,02 VL10	2711817.C0 € 52,25 VL14	2711817.C0 € 52,25 VL14	2711817.C0 € 52,25 VL14
	REED VALVE TEAM	-	-	-	-
	DIGITRONIC EPROM ELECTRONIC DIGITAL CONTROLLER	-	-	-	-
	INNER ROTOR IGNITION	5514690 € 328,50	5514690 € 328,50	5514690 € 328,50	5514690 € 328,50
	INNER ROTOR IGNITION TEAM	5515002 € 350,00	5515002 € 350,00	5515002 € 350,00	5515002 € 350,00

79 - Crankcase MODIFICATIONS: BORING - TO COUPLE ONLY with Multivar 5112800 or 5115823



Scooter 50

with ENGINE

MBK

BOOSTER SPIRIT
euro 0-1

EVOLIS

FIZZ

FLIPPER

50 2T



50 2T



50 2T



50 2T



	MULTIVAR VARIATOR	5113161 € 78,28	5113161 € 78,28	5113161 € 78,28	5113161 € 78,28
	MULTIVAR TEAM VARIATOR	-	-	-	-
	X K BELT BELT	6112729 € 25,23	6112742 € 26,33	6112742 € 26,33	6112729 € 25,23
	VENTILVAR HALF-PULLEY	61 7152 € 21,71	61 7152 € 21,71	61 7152 € 21,71	61 7152 € 21,71
	TORSION CONTROLLER ANTIFRICTION FIFTH WHEEL	2512827 € 4,45	2512827 € 4,45	2512827 € 4,45	2512827 € 4,45
	TORQUE DRIVER MOBILE DRIVEN SPLIT PULLEY	61 8312 (Ø 33) € 85,57 61 9223 (Ø 34) € 85,57	61 8312 (Ø 33) € 85,57 61 9223 (Ø 34) € 85,57	61 8312 (Ø 33) € 85,57 61 9223 (Ø 34) € 85,57	61 8312 (Ø 33) € 85,57 61 9223 (Ø 34) € 85,57
	DELTA CLUTCH ADJUSTABLE CLUTCH	52 7643 (Ø 105) € 77,89 52 9451 (Ø 107) € 77,89	52 7879 € 77,89	52 7879 € 77,89	52 9451 € 77,89
	WING CLUTCH BELL CLUTCH BELL (FINNED RING)	7714313 € 90,00 Ø 107	-	-	7714313 € 90,00 Ø 107
	DELTA SYSTEM MHR BELL + ADJUSTABLE CLUTCH	5214739 € 156,00	-	-	5214739 € 156,00
	ROLLER CRANKCASE GEAR-BOX COVERS	2515482 € 95,00	-	-	-
	ROLLER CRANKCASE TEAM GEAR-BOX COVERS	-	-	-	-
	PINWHEEL SHAFT	6714748 € 60,18	-	-	-
	GEARS HTQ PRIMARY	67 3677 € 57,67 z 16/40	67 7014 € 68,44 z 15/41	67 7014 € 68,44 z 15/41	6714039 € 57,67 z 13/44
	GEARS HTQ (PIAGGIO) PRIMARY	-	-	-	-
	COUPLING Ø 17	-	-	-	-
	COUPLING Ø 18	-	-	-	-
	GEARS HTQ SECONDARY	-	-	-	-
	PRESSED COUPLING Ø 17	-	-	-	-
	PG. 478 SPLINED COUPLING Ø 17	-	-	-	-
	COUPLING Ø 18	-	-	-	-
	SECOND ROLLER GEAR (COUPLING)	-	-	-	-
KIT	OVER RANGE / OVER RANGE ALUMINUM	6112811 € 272,85 6115821 € 365,00	6112812 € 272,85 6116249 € 365,00	6112812 € 272,85 6116249 € 365,00	6112811 € 272,85 6115821 € 365,00
	1 MULTIVAR / ALUMINUM VARIATOR	5112800 € 87,55 5115823 € 88,60	5112800 € 87,55 5115823 € 88,60	5112800 € 87,55 5115823 € 88,60	5112800 € 87,55 5115823 € 88,60
The Malossi OVER RANGE system must be installed AS A WHOLE	2 X K BELT BELT	6114116 € 38,25	6111108 € 27,80	6111108 € 27,80	6114116 € 38,25
	2 X K BELT TEAM / ALUMINUM	6115822 € 44,88	-	-	6115822 € 44,88
	3 REAR PULLEY SYSTEM / ALUMINUM REAR PULLEY	61 9733 € 170,82 6114590 € 275,31	6111121 € 169,52 6115991 € 275,31	6111121 € 169,52 6115991 € 275,31	61 9733 € 170,82 6114590 € 275,31
	WHOO DISC FRONT BRAKE DISC	6214097 € 62,00 1996->	6214097 € 62,00 1992->	6214097 € 62,00 1994->	-
	WHOO DISC REAR BRAKE DISC	-	-	-	-
	BRAKE PADS MHR FRONT ORGANIC BRAKE PADS	62 9083 € 6,20 1996->	62 9083 € 6,20 1992->	62 9083 € 6,20 1994->	-
	BRAKE PADS MHR SYNT FRONT SINTERED BRAKE PADS	6215008 € 11,96 1996->	6215008 € 11,96 1992->	6215008 € 11,96 1994->	-
	BRAKE PADS MHR REAR ORGANIC BRAKE PADS	-	-	-	-
	BRAKE PADS MHR SYNT REAR SINTERED BRAKE PADS	-	-	-	-
	RADIATOR / RADIATOR TEAM	-	-	-	-
	RS24/10 - RS24/10-R FRONT SHOCK ABSORBER	-	-	-	-
	RS24/10 - RS24/10-R REAR SHOCK ABSORBER	-	-	-	-
	RS24/10-R FRONT + REAR	-	-	-	-

56 - IF ASSEMBLED WITH CRANKSHAFTS 5313275 (5312810-5316048), USE 2015832 € 40,17



Scooter 50

with ENGINE

PIAGGIO

FREE

LIBERTY

NRG

NRG EXTREME

50 2T



50 2T



50 2T

LC

50 2T



TEAM Cylinder and crankshaft MUST BE INSTALLED AS A WHOLE

	CYLINDER+HEAD Ø 40 (pin)	31 8862	31 8862	31 8865	31 8862
		€ 174,92 (12)	€ 174,92 (12)	€ 213,72 (12)	€ 174,92 (12)
	CYLINDER+HEAD Ø 47-47,6 (pin)	31 8398	31 8398	31 8455	31 8398
		€ 267,15 Ø 47,6 (12)	€ 267,15 Ø 47,6 (12)	€ 301,54 Ø 47,6 (12)	€ 267,15 Ø 47,6 (12)
	CYLINDER+HEAD Ø 47,6 (pin)	-	-	3111584	-
	TEAM Replica	-	-	€ 324,71 (12)	-
	CRANKSHAFTS RHQ PIN Ø 12	53 7600	53 7600	53 7600	53 7600
	STROKE 39 mm CONNECTING ROD 80	€ 175,50	€ 175,50	€ 175,50	€ 175,50
	CYLINDER+HEAD Ø 40	31 8881 *38*	31 8881 *38*	31 8884	31 8881 *38*
	TEAM	€ 181,70	€ 181,70	€ 284,08	€ 181,70
	CYLINDER+HEAD Ø 47,6	-	-	3115142	-
	TEAM - TEAM 2 STROKE 39 mm C.ROD 80 - 85	-	-	€ 376,00	-
	CYLINDER+HEAD Ø 50	-	-	3113030	-
	BIG BORE STROKE 39 mm C.ROD 85	-	-	€ 367,50	-
	CRANKSHAFTS RHQ PIN Ø 12	53 9212	53 9212	53 9212	53 9212
	STROKE 39 mm C.ROD 85 - 80	€ 285,15	€ 285,15	€ 285,15	€ 285,15
	CRANKSHAFTS RHQ PIN Ø 12 - 13	5316005 *39*	5316005 *39*	5316005 *39*	5316005 *39*
	TEAM STROKE 39 mm C.ROD 85 - 80	€ 478,00	€ 478,00	€ 478,00	€ 478,00
	CYLINDER+HEAD Ø 50	-	-	3113042	-
	BIG BORE STROKE 44 mm C.ROD 85	-	-	€ 367,50	-
	CRANKSHAFTS RHQ PIN Ø 13	-	-	5313270 *73*	-
	BIG BORE STROKE 44 mm C.ROD 85	-	-	€ 450,00	-
	CYLINDER+HEAD Ø 52	-	-	3115385	-
	BIG BORE testa rossa STROKE 44 mm C.ROD 90	-	-	€ 430,00	-
	CRANKSHAFTS RHQ PIN Ø 13	-	-	5316029	-
	TEAM STROKE 44 mm C.ROD 90	-	-	€ 465,00	-
	RADIAL ROLLER BEARING Pg. 473	6614105EA	6614105EA	6614105EA	6614105EA
		€ 82,00	€ 82,00	€ 82,00	€ 82,00
	EXHAUST SYSTEM SCOOTER RACING Ø 40	-	-	-	-
	EXHAUST SYSTEM SCOOTER RACING Ø 47 - 47,6	32 9834	32 9834	32 9027	32 9027
		€ 377,08	€ 377,08	€ 314,23	€ 314,23
	EXHAUST SYSTEM SCOOTER RACING TEAM 2 Ø 47,6	-	-	-	-
	EXHAUST SYSTEM SCOOTER RACING TEAM 3 Ø 47,6	-	-	3215341	-
		-	-	€ 366,18	-
	EXHAUST SYSTEM SCOOTER RACING Ø 50	-	-	3215134	-
	BIG BORE 2 Ø 50 STROKE 39 - 44 mm	-	-	€ 366,18	-
	EXHAUST SYSTEM SCOOTER RACING Ø 52	-	-	3216158	-
	BIG BORE Ø 52 STROKE 44 mm	-	-	€ 366,18	-
	CARBURETTOR KIT PHBG Ø 19	1611021	1611021	1611021	1611021
		€ 129,40	€ 129,40	€ 129,40	€ 129,40
	PHBG Ø 19 TEAM	1611021.T	1611021.T	1611021.T	1611021.T
		€ 202,60	€ 202,60	€ 202,60	€ 202,60
	PHBG Ø 21 TEAM	1613890.TO	1613890.TO	1613890.TO	1613890.TO
		€ 210,60	€ 210,60	€ 210,60	€ 210,60
	PHBL Ø 25	1611009	1611009	1611009	1611009
		€ 217,99	€ 217,99	€ 217,99	€ 217,99
	VHST Ø 28 TEAM	1613766	1613766	1613766	1613766
		€ 251,86	€ 251,86	€ 251,86	€ 251,86
	INTAKE MANIFOLDS Ø 22 x 24,5 RUBBER NBR	02 8732B	02 8732B	02 8732B	02 8732B
		€ 52,50	€ 52,50	€ 52,50	€ 52,50
	RUBBER FKM	02 9732B	02 9732B	02 9732B	02 9732B
		€ 65,10	€ 65,10	€ 65,10	€ 65,10
	INTAKE MANIFOLDS Ø 22 x 28 RUBBER NBR	02 8856B	02 8856B	02 8856B	02 8856B
		€ 52,50	€ 52,50	€ 52,50	€ 52,50
	RUBBER FKM	02 9441B	02 9441B	02 9441B	02 9441B
		€ 65,10	€ 65,10	€ 65,10	€ 65,10
	INTAKE MANIFOLDS X360 Ø 22 x 24,5 RUBBER FKM	2014520	2014520	2014520	2014520
		€ 52,02	€ 52,02	€ 52,02	€ 52,02
	RUBBER FKM Ø 22 x 28	2014519	2014519	2014519	2014519
		€ 52,02	€ 52,02	€ 52,02	€ 52,02
	RUBBER FKM Ø 30 x 35	2013802	2013802	2013802	2013802
		€ 52,02	€ 52,02	€ 52,02	€ 52,02
	REED VALVE CARBON FIBRE	27 9490.CO	27 9490.CO	27 9490.CO	27 9490.CO
		€ 52,25 VL13	€ 52,25 VL13	€ 52,25 VL13	€ 52,25 VL13
	REED VALVE TEAM CARBON FIBRE	2713719.CO *19*	2713719.CO *19*	2713719.CO *19*	2713719.CO *19*
		€ 57,68 VL16	€ 57,68 VL16	€ 57,68 VL16	€ 57,68 VL16
	DIGITRONIC EPROM ELECTRONIC DIGITAL CONTROLLER	55 9002	55 9002	55 9002	55 9002
		€ 189,75	€ 189,75	€ 189,75	€ 189,75
	INNER ROTOR IGNITION	5514689	5514689	5514691 € 328,50	5514689
	INNER ROTOR IGNITION TEAM	€ 318,50	€ 318,50	5515001 € 350,00	€ 318,50

19 - for the ASSEMBLY MODIFY the CRANKCASE

38 - IT IS NOT MODULAR-head

39 - WE SUGGEST TO USE bearings : 6614105EA € 82,00

40 - For CROSS model: Ø 47,6 (12) 31 8455 € 301,54

PIAGGIO

PIAGGIO							
NRG EXTREME	NRG MC2 <-1997	NRG MC2 1998->	NRG MC3 DD	NRG MC3 DT	NRG Power DD	NRG Power DT	NTT
						(C453M)	
50 2T LC	50 2T LC	50 2T LC	50 2T LC	50 2T	50 2T LC	50 2T	50 2T LC
31 8865 € 213,72 (12)	31 8865 € 213,72 (12)	31 8865 € 213,72 (12)	31 8865 € 213,72 (12)	31 8862 € 174,92 (12)	31 8865 € 213,72 (12)	31 8862 € 174,92 (12)	31 8865 € 213,72 (12)
31 8455 € 301,54 Ø 47,6 (12)	31 8455 € 301,54 Ø 47,6 (12)	31 8455 € 301,54 Ø 47,6 (12)	31 8455 € 301,54 Ø 47,6 (12)	31 8398 € 267,15 Ø 47,6 (12)	31 8455 € 301,54 Ø 47,6 (12)	31 8398 € 267,15 Ø 47,6 (12)	*40*
3111584 € 324,71 (12)	3111584 € 324,71 (12)	3111584 € 324,71 (12)	3111584 € 324,71 (12)	-	3111584 € 324,71 (12)	-	3111584 € 324,71 (12)
53 7600 € 175,50	53 7600 € 175,50	53 7600 € 175,50	53 7600 € 175,50	53 7600 € 175,50	53 7600 € 175,50	53 7600 € 175,50	*40*
31 8884 € 284,08	31 8884 € 284,08	31 8884 € 284,08	31 8884 € 284,08	31 8881 *38* € 181,70	31 8884 € 284,08	31 8881 *38* € 181,70	-
3115142 € 376,00	3115142 € 376,00	3115142 € 376,00	3115142 € 376,00	-	3115142 € 376,00	-	3115142 € 376,00
3113030 € 367,50	3113030 € 367,50	3113030 € 367,50	3113030 € 367,50	-	3113030 € 367,50	-	3113030 € 367,50
53 9212 € 285,15	53 9212 € 285,15	53 9212 € 285,15	53 9212 € 285,15	53 9212 € 285,15	53 9212 € 285,15	53 9212 € 285,15	53 9212 € 285,15
5316005 *39* € 478,00	5316005 *39* € 478,00	5316005 *39* € 478,00	5316005 *39* € 478,00	5316005 *39* € 478,00	5316005 *39* € 478,00	5316005 *39* € 478,00	5316005 *39* € 478,00
3113042 € 367,50	3113042 € 367,50	3113042 € 367,50	3113042 € 367,50	-	3113042 € 367,50	-	3113042 € 367,50
5313270 *73* € 450,00	5313270 *73* € 450,00	5313270 *73* € 450,00	5313270 *73* € 450,00	-	5313270 *73* € 450,00	-	5313270 *73* € 450,00
3115385 € 430,00	3115385 € 430,00	3115385 € 430,00	3115385 € 430,00	-	3115385 € 430,00	-	3115385 € 430,00
5316029 € 465,00	5316029 € 465,00	5316029 € 465,00	5316029 € 465,00	-	5316029 € 465,00	-	5316029 € 465,00
6614105EA € 82,00	6614105EA € 82,00	6614105EA € 82,00	6614105EA € 82,00	6614105EA € 82,00	6614105EA € 82,00	6614105EA € 82,00	6614105EA € 82,00
-	-	-	-	-	-	-	-
32 9027 € 314,23	32 9027 € 314,23	32 9027 € 314,23	32 9027 € 314,23	32 9027 € 314,23	32 9027 € 314,23	32 9027 € 314,23	32 9027 € 314,23
-	-	-	-	-	-	-	-
3215341 € 366,18	3215341 € 366,18	3215341 € 366,18	3215341 € 366,18	-	3215341 € 366,18	-	3215341 € 366,18
3215134 € 366,18	3215134 € 366,18	3215134 € 366,18	3215134 € 366,18	-	3215134 € 366,18	-	3215134 € 366,18
3216158 € 366,18	3216158 € 366,18	3216158 € 366,18	3216158 € 366,18	-	3216158 € 366,18	-	3216158 € 366,18
1611021 € 129,40	1611021 € 129,40	1611021 € 129,40	1611021 € 129,40	1611021 € 129,40	1611021 € 129,40	1611021 € 129,40	1611021 € 129,40
1611021.T € 202,60	1611021.T € 202,60	1611021.T € 202,60	1611021.T € 202,60	1611021.T € 202,60	1611021.T € 202,60	1611021.T € 202,60	1611021.T € 202,60
1613890.TO € 210,60	1613890.TO € 210,60	1613890.TO € 210,60	1613890.TO € 210,60	1613890.TO € 210,60	1613890.TO € 210,60	1613890.TO € 210,60	1613890.TO € 210,60
1611009 € 217,99	1611009 € 217,99	1611009 € 217,99	1611009 € 217,99	1611009 € 217,99	1611009 € 217,99	1611009 € 217,99	1611009 € 217,99
1613766 € 251,86	1613766 € 251,86	1613766 € 251,86	1613766 € 251,86	-	1613766 € 251,86	-	1613766 € 251,86
02 8732B € 52,50	02 8732B € 52,50	02 8732B € 52,50	02 8732B € 52,50	02 8732B € 52,50	02 8732B € 52,50	02 8732B € 52,50	02 8732B € 52,50
02 9732B € 65,10	02 9732B € 65,10	02 9732B € 65,10	02 9732B € 65,10	02 9732B € 65,10	02 9732B € 65,10	02 9732B € 65,10	02 9732B € 65,10
02 8856B € 52,50	02 8856B € 52,50	02 8856B € 52,50	02 8856B € 52,50	02 8856B € 52,50	02 8856B € 52,50	02 8856B € 52,50	02 8856B € 52,50
02 9441B € 65,10	02 9441B € 65,10	02 9441B € 65,10	02 9441B € 65,10	02 9441B € 65,10	02 9441B € 65,10	02 9441B € 65,10	02 9441B € 65,10
2014520 € 52,02	2014520 € 52,02	2014520 € 52,02	2014520 € 52,02	2014520 € 52,02	2014520 € 52,02	2014520 € 52,02	2014520 € 52,02
2014519 € 52,02	2014519 € 52,02	2014519 € 52,02	2014519 € 52,02	2014519 € 52,02	2014519 € 52,02	2014519 € 52,02	2014519 € 52,02
2013802 € 52,02	2013802 € 52,02	2013802 € 52,02	2013802 € 52,02	2013802 € 52,02	2013802 € 52,02	2013802 € 52,02	2013802 € 52,02
27 9490.CO € 52,25 VL13	27 9490.CO € 52,25 VL13	27 9490.CO € 52,25 VL13	27 9490.CO € 52,25 VL13	27 9490.CO € 52,25 VL13	27 9490.CO € 52,25 VL13	27 9490.CO € 52,25 VL13	27 9490.CO € 52,25 VL13
2713719.CO *19* € 57,68 VL16	2713719.CO *19* € 57,68 VL16	2713719.CO *19* € 57,68 VL16	2713719.CO *19* € 57,68 VL16	2713719.CO *19* € 57,68 VL16	2713719.CO *19* € 57,68 VL16	2713719.CO *19* € 57,68 VL16	2713719.CO *19* € 57,68 VL16
55 9002 € 189,75	55 9002 € 189,75	55 9002 € 189,75	55 9002 € 189,75	55 9002 € 189,75	55 9002 € 189,75	55 9002 € 189,75	55 9002 € 189,75
5514691 € 328,50 5515001 € 350,00	5514691 € 328,50 5515001 € 350,00	5514691 € 328,50 5515001 € 350,00	5514691 € 328,50 5515001 € 350,00	5514691 € 328,50 5515001 € 350,00	5514691 € 328,50 5515001 € 350,00	5514689 € 318,50	5514691 € 328,50 5515001 € 350,00

73 - Crankcase MODIFICATIONS: BORING - WE SUGGEST TO USE bearings 6614105EA



Scooter 50

with ENGINE

PIAGGIO

FREE

LIBERTY

NRG

NRG EXTREME

50 2T



50 2T



50 2T

LC

50 2T



	MULTIVAR VARIATOR	51 8648 € 68,00 <-2000	-	51 8648 € 68,00	-
	MULTIVAR TEAM VARIATOR	5112645 € 77,25	5112645 € 77,25	5112645 € 77,25	5112645 € 77,25
	X K BELT BELT	61 7587 <-2000 € 28,25 6114118 2001-> € 38,25	61 9535 € 28,72	61 7587 € 28,25 6114118 € 38,25	6114118 € 38,25
	VENTILVAR HALF-PULLEY	6113416B *59* € 36,72	6113416B *59* € 36,72	6113416B *59* € 36,72	6113416B *59* € 36,72
	TORSION CONTROLLER ANTIFRICTION FIFTH WHEEL	2512828 € 4,45	2512828 € 4,45	2512828 € 4,45	2512828 € 4,45
	TORQUE DRIVER MOBILE DRIVEN SPLIT PULLEY	61 8233 <-2000 € 85,57 61 9100 2001-> € 85,57	61 9100 € 85,57	61 8233 € 85,57	61 9100 € 85,57
	DELTA CLUTCH ADJUSTABLE CLUTCH	52 7880 € 77,89	52 7880 € 77,89	52 7880 € 77,89	52 7880 € 77,89
	WING CLUTCH BELL CLUTCH BELL (FINNED RING)	7714147 € 90,00 Ø 107	7714147 € 90,00 Ø 107	7714147 € 90,00 Ø 107	7714147 € 90,00 Ø 107
	DELTA SYSTEM MHR BELL + ADJUSTABLE CLUTCH	5214738 € 156,00	5214738 € 156,00	5214738 € 156,00	5214738 € 156,00
	ROLLER CRANKCASE GEAR-BOX COVERS	2514521 *66* € 95,00 2001->	2514521 *66* € 95,00	-	2514521 *66* € 95,00
	ROLLER CRANKCASE TEAM GEAR-BOX COVERS	2514603 *66* € 95,00 2001->	2514603 *66* € 95,00	-	2514603 *66* € 95,00
	PINWHEEL SHAFT	6714530 € 66,30 2001->	6714530 € 66,30	-	6714530 € 66,30
	GEARS HTQ PRIMARY	-	-	-	-
	GEARS HTQ (PIAGGIO) PRIMARY	67 8220 € 56,53 z 14/39	-	67 8220 € 56,53 z 14/39	67 9080 z 14/39 € 60,41 6713339 z 15/38 € 61,71
		67 8218 € 56,53 z 14/39	-	67 8218 € 56,53 z 14/39	-
	GEARS HTQ SECONDARY	67 9968 *PG* € 61,65 z 14/47	6711135 *PG* € 58,86 z15/55 (17)	-	67 9966 *PG* € 65,00 z 13/48
		67 8939 *PG* € 60,41 z 14/47	-	67 8938 *PG* € 60,41 z 13/48	-
		67 8717 *PG* € 59,22 z 14/47	-	-	-
	SECOND ROLLER GEAR (COUPLING)	67 9969 *PG* € 71,36 z 14/47 (17)	-	67 8714 *PG* € 63,98 z 13/48 (18)	67 9967 *PG* € 71,36 z 13/48 (17)
KIT	OVER RANGE / OVER RANGE ALUMINUM	6114219 2001-> € 262,65 6115781 € 365,00 (*37*)	-	6114216 € 251,48	6114219 € 262,65 6115781 € 365,00
	1 MULTIVAR / ALUMINUM VARIATOR	5112645 2001-> € 77,25 5115644 € 87,55	-	5112645 € 77,25	5112645 2001-> € 77,25 5115644 € 87,55
	2 X K BELT BELT	6114118 € 38,25 2001->	-	6114118 € 38,25	6114118 € 38,25
	2 X K BELT TEAM / ALUMINUM	6115668 € 44,88 2001->	-	-	6115668 € 44,88
	3 REAR PULLEY SYSTEM / ALUMINUM REAR PULLEY	6113101 2001-> € 174,40 6114582 € 275,31 (*37*)	-	6112110 € 163,82	6113101 € 174,40 6114582 € 275,31
	WHOO DISC FRONT BRAKE DISC	-	-	6212603 € 72,56	6212929 € 105,00 1998->
	WHOO DISC REAR BRAKE DISC	-	-	-	-
	BRAKE PADS MHR ORGANIC BRAKE PADS	FRONT 62 9841 € 6,10 1995->	6215074 € 6,30 1997->	6215080 € 6,00	6215080 € 6,00 1998->
	BRAKE PADS MHR SYNT SINTERED BRAKE PADS	FRONT -	6215006 € 11,96 1997->	6215007 € 11,96	6215007 € 11,96 1998->
	BRAKE PADS MHR ORGANIC BRAKE PADS	REAR -	-	-	-
	BRAKE PADS MHR SYNT SINTERED BRAKE PADS	REAR -	-	-	-
	RADIATOR / RADIATOR TEAM	-	-	71 9629 € 1187,85	-
	RS24/10 - RS24/10-R FRONT SHOCK ABSORBER	-	-	-	-
	RS24/10 - RS24/10-R REAR SHOCK ABSORBER	4614237 € 428,82	4614237 € 428,82	-	-
	RS24/10-R FRONT + REAR	-	-	-	-

37 - for vehicles PRODUCED <-2000: OVER RANGE 6114216 € 251,48 - REAR PULLEY SYST. 6112110 € 163,82 - X KEVLAR 6114118 € 38,25

59 - ELECTRIC STARTER IS CUT OUT

66 - NOT to be used on VEHICLE WITH ORIGINAL PRIMARY GEARS

83 - For vehicles PRODUCED 2007-> with Heng Tong CALIPER: 6212164 € 8,50

PIAGGIO

PIAGGIO							
NRG EXTREME	NRG MC2 <-1997	NRG MC2 1998->	NRG MC3 DD	NRG MC3 DT	NRG Power DD	NRG Power DT	NTT
						(C453M)	
50 2T LC	50 2T LC	50 2T LC	50 2T LC	50 2T ⚠	50 2T LC	50 2T ⚠	50 2T LC
-	51 8648 € 68,00	-	-	-	-	-	51 8648 € 68,00
5112645 € 77,25	5112645 € 77,25	5112645 € 77,25	5112645 € 77,25	5112645 € 77,25	5112645 € 77,25	5112645 € 77,25	5112645 € 77,25
6114118 € 38,25	61 7587 € 28,25 6114118 € 38,25	6114118 € 38,25	6114118 € 38,25	6114118 € 38,25	6114118 € 38,25	6114118 € 38,25	61 7587 € 28,25 6114118 € 38,25
6113416B *59* € 36,72	6113416B *59* € 36,72	6113416B *59* € 36,72	6113416B *59* € 36,72	6113416B *59* € 36,72	6113416B *59* € 36,72	6113416B *59* € 36,72	6113416B *59* € 36,72
2512828 € 4,45	2512828 € 4,45	2512828 € 4,45	2512828 € 4,45	2512828 € 4,45	2512828 € 4,45	2512828 € 4,45	2512828 € 4,45
61 9100 € 85,57	61 8233 € 85,57	61 9100 € 85,57	61 9100 € 85,57	61 9100 € 85,57	61 9100 € 85,57	61 9100 € 85,57	61 8233 € 85,57
52 7880 € 77,89	52 7880 € 77,89	52 7880 € 77,89	52 7880 € 77,89	52 7880 € 77,89	52 7880 € 77,89	52 7880 € 77,89	52 7880 € 77,89
7714147 € 90,00 Ø 107	7714147 € 90,00 Ø 107	7714147 € 90,00 Ø 107	7714147 € 90,00 Ø 107	7714147 € 90,00 Ø 107	7714147 € 90,00 Ø 107	7714147 € 90,00 Ø 107	7714147 € 90,00 Ø 107
5214738 € 156,00	5214738 € 156,00	5214738 € 156,00	5214738 € 156,00	5214738 € 156,00	5214738 € 156,00	5214738 € 156,00	5214738 € 156,00
2514521 *66* € 95,00	-	2514521 *66* € 95,00	2514521 *66* € 95,00	2514521 *66* € 95,00	2514521 *66* € 95,00	2514521 *66* € 95,00	-
2514603 *66* € 95,00	-	2514603 *66* € 95,00	2514603 *66* € 95,00	2514603 *66* € 95,00	2514603 *66* € 95,00	2514603 *66* € 95,00	-
6714530 € 66,30	-	6714530 € 66,30	6714530 € 66,30	6714530 € 66,30	6714530 € 66,30	6714530 € 66,30	-
-	-	-	-	-	-	-	-
67 9080 z 14/39 € 60,41 6713339 z 15/38 € 61,71	67 8220 € 56,53 z 14/39	67 9080 z 14/39 € 60,41 6713339 z 15/38 € 61,71	67 9080 z 14/39 € 60,41 6713339 z 15/38 € 61,71	67 9080 z 14/39 € 60,41 6713339 z 15/38 € 61,71	67 9080 z 14/39 € 60,41 6713339 z 15/38 € 61,71	67 9080 z 14/39 € 60,41 6713339 z 15/38 € 61,71	67 8220 € 56,53 z 14/39
-	67 8218 € 56,53 z 14/39	-	-	-	-	-	67 8218 € 56,53 z 14/39
67 9966 *PG* € 65,00 z 13/48	-	67 9966 *PG* € 65,00 z 13/48	67 9966 € 65,00 z 13/48	67 9966 € 65,00 z 13/48	67 9966 € 65,00 z 13/48	67 9966 € 65,00 z 13/48	-
-	67 8938 *PG* € 60,41 z 13/48	-	-	-	-	-	67 8938 *PG* € 60,41 z 13/48
-	-	-	-	-	-	-	-
67 9967 *PG* € 71,36 z 13/48 (17)	67 8714 *PG* € 63,98 z 13/48 (18)	67 9967 *PG* € 71,36 z 13/48 (17)	67 9967 € 71,36 z 13/48 (17)	67 9967 € 71,36 z 13/48 (17)	67 9967 € 71,36 z 13/48 (17)	67 9967 € 71,36 z 13/48 (17)	67 8714 *PG* € 63,98 z 13/48 (18)
6114219 € 262,65 6115781 € 365,00	6114216 € 251,48	6114219 € 262,65 6115781 € 365,00	6114219 € 262,65 6115781 € 365,00	6114219 € 262,65 6115781 € 365,00	6114219 € 262,65 6115781 € 365,00	6114219 € 262,65 6115781 € 365,00	6114216 € 251,48
5112645 2001-> € 77,25 5115644 € 87,55	5112645 € 77,25	5112645 2001-> € 77,25 5115644 € 87,55	5112645 2001-> € 77,25 5115644 € 87,55	5112645 2001-> € 77,25 5115644 € 87,55	5112645 2001-> € 77,25 5115644 € 87,55	5112645 2001-> € 77,25 5115644 € 87,55	5112645 € 77,25
6114118 € 38,25	6114118 € 38,25	6114118 € 38,25	6114118 € 38,25	6114118 € 38,25	6114118 € 38,25	6114118 € 38,25	6114118 € 38,25
6115668 € 44,88	-	6115668 € 44,88	6115668 € 44,88	6115668 € 44,88	6115668 € 44,88	6115668 € 44,88	-
6113101 € 174,40 6114582 € 275,31	6112110 € 163,82	6113101 € 174,40 6114582 € 275,31	6113101 € 174,40 6114582 € 275,31	6113101 € 174,40 6114582 € 275,31	6113101 € 174,40 6114582 € 275,31	6113101 € 174,40 6114582 € 275,31	6112110 € 163,82
6212929 € 105,00 1998->	6212603 € 72,56 1996->	6212603 € 72,56	6212929 € 105,00 1998->	6212929 € 105,00 1998->	6212929 € 105,00 1998->	-	6212603 € 72,56
-	-	-	-	-	-	-	-
6215080 € 6,00 1998->	6215080 € 6,00 1996->	6215080 € 6,00	6215080 € 6,00 1998->	6215080 € 6,00 1998->	6215080 *83* € 6,00 1998->	-	6215080 *83* € 6,00 1995->
6215007 € 11,96 1998->	6215007 € 11,96 1996->	6215007 € 11,96	6215007 € 11,96 1998->	6215007 € 11,96 1998->	6215007 € 11,96 1998->	-	6215007 € 11,96 1995->
-	-	-	6215074 € 6,30 1998->	-	6215074 € 6,30 1998->	-	-
-	-	-	6215006 € 11,96 1998->	-	6215006 € 11,96 1998->	-	-
-	71 9629 € 1187,85	-	-	-	-	-	71 9629 € 1187,85
-	-	-	-	-	-	-	-
-	-	-	-	-	-	-	-
-	-	-	-	-	-	-	-

SCOOTER 2T MHR

PG - SPECIFICATIONS on the PAGE indicated in the TITLE of the LINE



Scooter 50

with ENGINE

PIAGGIO

QUARTZ

SFERA
RETYLINGTYPHOON
2007->2010TYPHOON
euro 2
2011->

(C421M)

50 2T

LC

50 2T

50 2T

50 2T

! TEAM Cylinder and crankshaft MUST BE INSTALLED AS A WHOLE		50 2T	LC	50 2T		50 2T		50 2T	
	CYLINDER+HEAD Ø 40 (pin)	31 8865	€ 213,72 (12)	31 8862	€ 174,92 (12)	31 8862	€ 174,92 (12)	31 8862	€ 174,92 (12)
	CYLINDER+HEAD Ø 47-47,6 (pin)	31 8455	€ 301,54 Ø 47,6 (12)	31 8398	€ 267,15 Ø 47,6 (12)	31 8398	€ 267,15 Ø 47,6 (12)	31 8398	€ 267,15 Ø 47,6 (12)
	CYLINDER+HEAD Ø 47,6 (pin)	3111584	€ 324,71 (12)	-	-	-	-	-	-
	CRANKSHAFTS RHQ PIN Ø 12 STROKE 39 mm CONNECTING ROD 80	53 7600	€ 175,50	53 7600	€ 175,50	53 7600	€ 175,50	53 7600	€ 175,50
	CYLINDER+HEAD Ø 40 TEAM	31 8884	€ 284,08	31 8881 *38*	€ 181,70	31 8881 *38*	€ 181,70	31 8881 *38*	€ 181,70
	CYLINDER+HEAD Ø 47,6 TEAM - TEAM 2 STROKE 39 mm C.ROD 80 - 85	3115142	€ 376,00	-	-	-	-	-	-
	CYLINDER+HEAD Ø 50 BIG BORE STROKE 39 mm C.ROD 85	3113030	€ 367,50	-	-	-	-	-	-
	CRANKSHAFTS RHQ PIN Ø 12 STROKE 39 mm C.ROD 85 - 80	53 9212	€ 285,15	53 9212	€ 285,15	53 9212	€ 285,15	53 9212	€ 285,15
	CRANKSHAFTS RHQ PIN Ø 12 - 13 TEAM STROKE 39 mm C.ROD 85 - 80	5316005 *39*	€ 478,00	5316005 *39*	€ 478,00	5316005 *39*	€ 478,00	5316005 *39*	€ 478,00
	CYLINDER+HEAD Ø 50 BIG BORE STROKE 44 mm C.ROD 85	3113042	€ 367,50	-	-	-	-	-	-
	CRANKSHAFTS RHQ PIN Ø 13 BIG BORE STROKE 44 mm C.ROD 85	5313270 *73*	€ 450,00	-	-	-	-	-	-
	CYLINDER+HEAD Ø 52 BIG BORE testa rossa STROKE 44 mm C.ROD 90	3115385	€ 430,00	-	-	-	-	-	-
	CRANKSHAFTS RHQ PIN Ø 13 TEAM STROKE 44 mm C.ROD 90	5316029	€ 465,00	-	-	-	-	-	-
	RADIAL ROLLER BEARING Pg. 473	6614105EA	€ 82,00	6614105EA	€ 82,00	6614105EA	€ 82,00	6614105EA	€ 82,00
	EXHAUST SYSTEM SCOOTER RACING Ø 40	-	-	-	-	-	-	-	-
	EXHAUST SYSTEM SCOOTER RACING Ø 47 - 47,6	32 9834	€ 377,08	32 9834	€ 377,08	32 9027	€ 314,23	32 9027	€ 314,23
	EXHAUST SYSTEM SCOOTER RACING Ø 47,6 TEAM 2	-	-	-	-	-	-	-	-
	EXHAUST SYSTEM SCOOTER RACING Ø 47,6 TEAM 3	3215341	€ 366,18	-	-	-	-	-	-
	EXHAUST SYSTEM SCOOTER RACING Ø 50 BIG BORE 2 Ø 50 STROKE 39 - 44 mm	3215134	€ 366,18	-	-	-	-	-	-
	EXHAUST SYSTEM SCOOTER RACING Ø 52 BIG BORE Ø 52 STROKE 44 mm	3216158	€ 366,18	-	-	-	-	-	-
	CARBURETTOR KIT PHBG Ø 19	1611021	€ 129,40	1611021	€ 129,40	1611021	€ 129,40	1611021	€ 129,40
	PHBG Ø 19 TEAM	1611021.T	€ 202,60	1611021.T	€ 202,60	1611021.T	€ 202,60	1611021.T	€ 202,60
	PHBG Ø 21 TEAM	1613890.TO	€ 210,60	1613890.TO	€ 210,60	1613890.TO	€ 210,60	1613890.TO	€ 210,60
	PHBL Ø 25	1611009	€ 217,99	1611009	€ 217,99	1611009	€ 217,99	1611009	€ 217,99
	VHST Ø 28 TEAM	1613766	€ 251,86	1613766	€ 251,86	1613766	€ 251,86	1613766	€ 251,86
	INTAKE MANIFOLDS Ø 22 x 24,5 RUBBER NBR	02 8732B	€ 52,50	02 8732B	€ 52,50	02 8732B	€ 52,50	02 8732B	€ 52,50
	RUBBER FKM	02 9732B	€ 65,10	02 9732B	€ 65,10	02 9732B	€ 65,10	02 9732B	€ 65,10
	INTAKE MANIFOLDS Ø 22 x 28 RUBBER NBR	02 8856B	€ 52,50	02 8856B	€ 52,50	02 8856B	€ 52,50	02 8856B	€ 52,50
	RUBBER FKM	02 9441B	€ 65,10	02 9441B	€ 65,10	02 9441B	€ 65,10	02 9441B	€ 65,10
	INTAKE MANIFOLDS X360 Ø 22 x 24,5 RUBBER FKM	2014520	€ 52,02	2014520	€ 52,02	2014520	€ 52,02	2014520	€ 52,02
	RUBBER FKM	2014519	€ 52,02	2014519	€ 52,02	2014519	€ 52,02	2014519	€ 52,02
	RUBBER FKM	2013802	€ 52,02	2013802	€ 52,02	2013802	€ 52,02	2013802	€ 52,02
	REED VALVE CARBON FIBRE	27 9490.CO	€ 52,25 VL13	27 9490.CO	€ 52,25 VL13	27 9490.CO	€ 52,25 VL13	27 9490.CO	€ 52,25 VL13
	REED VALVE CARBON FIBRE TEAM	2713719.CO *19*	€ 57,68 VL16	2713719.CO *19*	€ 57,68 VL16	2713719.CO *19*	€ 57,68 VL16	2713719.CO *19*	€ 57,68 VL16
	DIGITRONIC EPROM ELECTRONIC DIGITAL CONTROLLER	55 9002	€ 189,75	55 9002	€ 189,75	55 9002	€ 189,75	55 9002	€ 189,75
	INNER ROTOR IGNITION	5514691	€ 328,50	5514689	€ 318,50	5514689	€ 318,50	5514689	€ 318,50
	INNER ROTOR IGNITION TEAM	5515001	€ 350,00	-	-	-	-	-	-

19 - for the ASSEMBLY MODIFY the CRANKCASE

38 - IT IS NOT MODULAR-head

39 - WE SUGGEST TO USE bearings : 6614105EA € 82,00

PIAGGIO					VESPA	YAMAHA	
ZIP <-1999	ZIP 2000->	ZIP Fast Rider	ZIP SP <-2000	ZIP SP 2001->	ET2 <-1999	AEROX euro 0-1	AEROX euro 2
50 2T	50 2T	50 2T	50 2T	50 2T	50 2T	50 2T	50 2T
			LC	LC		LC	LC
31 8862 € 174,92 (12)	31 8862 € 174,92 (12)	31 8862 € 174,92 (12)	31 8865 € 213,72 (12)	31 8865 € 213,72 (12)	31 8862 € 174,92 (12)	31 8559 € 209,16 (10)	31 8559 € 209,16 (10)
31 8398 € 267,15 Ø 47,6 (12)	31 8398 € 267,15 Ø 47,6 (12)	31 8398 € 267,15 Ø 47,6 (12)	31 8455 € 301,54 Ø 47,6 (12)	31 8455 € 301,54 Ø 47,6 (12)	31 8398 € 267,15 Ø 47,6 (12)	31 8460 € 301,54 Ø 47,6 (12)	31 8460 € 301,54 Ø 47,6 (12)
-	-	-	3111584 € 324,71 (12)	3111584 € 324,71 (12)	-	-	-
53 7600 € 175,50	53 7600 € 175,50	53 7600 € 175,50	53 7600 € 175,50	53 7600 € 175,50	53 7600 € 175,50	53 8009 € 175,50	53 8009 € 175,50
31 8881 *38* € 181,70	31 8881 *38* € 181,70	31 8881 *38* € 181,70	31 8884 € 284,08	31 8884 € 284,08	31 8881 *38* € 181,70	3111511 € 302,14	3111511 € 302,14
-	-	-	3115142 € 376,00	3115142 € 376,00	-	3112642 € 357,72	3112642 € 357,72
-	-	-	3113030 € 367,50	3113030 € 367,50	-	-	-
53 9212 € 285,15	53 9212 € 285,15	53 9212 € 285,15	53 9212 € 285,15	53 9212 € 285,15	53 9212 € 285,15	53 8855 € 177,14 53 8009 € 175,50	53 8855 € 177,14 53 8009 € 175,50
5316005 *39* € 478,00	5316005 *39* € 478,00	5316005 *39* € 478,00	5316005 *39* € 478,00	5316005 *39* € 478,00	5316005 *39* € 478,00	5315973 € 480,00 5314548 € 465,00	5315973 € 480,00 5314548 € 465,00
-	-	-	3113042 € 367,50	3113042 € 367,50	-	-	-
-	-	-	5313270 *73* € 450,00	5313270 *73* € 450,00	-	5313275 *79* € 450,00	5313275 *79* € 450,00
-	-	-	3115385 € 430,00	3115385 € 430,00	-	3115374 € 430,00	3115374 € 430,00
-	-	-	5316029 € 465,00	5316029 € 465,00	-	5316039 *79* € 465,00	5316039 *79* € 465,00
6614105EA € 82,00	6614105EA € 82,00	6614105EA € 82,00	6614105EA € 82,00	6614105EA € 82,00	6614105EA € 82,00	PG.473	PG.473
-	32 8866 € 308,06	-	32 8866 € 308,06	32 8866 € 308,06	-	3212825 € 308,06 DISMANTLED	3212825 € 308,06 DISMANTLED
32 9834 € 377,08	32 9834 € 377,08	32 9834 € 377,08	32 9834 € 377,08	32 9834 € 377,08	-	-	-
-	-	-	-	-	-	3214763 € 366,18	3214763 € 366,18
-	-	-	3215341 € 366,18	3215341 € 366,18	-	-	-
-	-	-	3215134 € 366,18	3215134 € 366,18	-	3215198 € 366,18	3215198 € 366,18
-	-	-	3216158 € 366,18	3216158 € 366,18	-	3216827 € 366,18	3216827 € 366,18
1611021 € 129,40	1611021 € 129,40	1611021 € 129,40	1611021 € 129,40	1611021 € 129,40	1611021 € 129,40	1611021 € 129,40	1611021 € 129,40
1611021.T € 202,60	1611021.T € 202,60	1611021.T € 202,60	1611021.T € 202,60	1611021.T € 202,60	1611021.T € 202,60	1611021.T € 202,60	1611021.T € 202,60
1613890.TO € 210,60	1613890.TO € 210,60	1613890.TO € 210,60	1613890.TO € 210,60	1613890.TO € 210,60	1613890.TO € 210,60	1613890.TO € 210,60	1613890.TO € 210,60
1611009 € 217,99	1611009 € 217,99	1611009 € 217,99	1611009 € 217,99	1611009 € 217,99	1611009 € 217,99	1611013 € 217,38	1611013 € 217,38
1613766 € 251,86	1613766 € 251,86	1613766 € 251,86	1613766 € 251,86	1613766 € 251,86	1613766 € 251,86	1614022 € 251,86	1614022 € 251,86
02 8732B € 52,50	02 8732B € 52,50	02 8732B € 52,50	02 8732B € 52,50	02 8732B € 52,50	02 8732B € 52,50	0213222B € 52,50	0213222B € 52,50
02 9732B € 65,10	02 9732B € 65,10	02 9732B € 65,10	02 9732B € 65,10	02 9732B € 65,10	02 9732B € 65,10	0213661B € 65,10	0213661B € 65,10
02 8856B € 52,50	02 8856B € 52,50	02 8856B € 52,50	02 8856B € 52,50	02 8856B € 52,50	02 8856B € 52,50	02 8857B € 52,50	02 8857B € 52,50
02 9441B € 65,10	02 9441B € 65,10	02 9441B € 65,10	02 9441B € 65,10	02 9441B € 65,10	02 9441B € 65,10	0213662B € 65,10	0213662B € 65,10
2014520 € 52,02	2014520 € 52,02	2014520 € 52,02	2014520 € 52,02	2014520 € 52,02	2014520 € 52,02	2014524 € 52,02	2014524 € 52,02
2014519 € 52,02	2014519 € 52,02	2014519 € 52,02	2014519 € 52,02	2014519 € 52,02	2014519 € 52,02	2014525 € 52,02	2014525 € 52,02
2013802 € 52,02	2013802 € 52,02	2013802 € 52,02	2013802 € 52,02	2013802 € 52,02	2013802 € 52,02	2013847 € 52,02	2013847 € 52,02
27 9490.CO € 52,25 VL13	27 9490.CO € 52,25 VL13	27 9490.CO € 52,25 VL13	27 9490.CO € 52,25 VL13	27 9490.CO € 52,25 VL13	27 9490.CO € 52,25 VL13	2711817.CO € 52,25 VL14	2711817.CO € 52,25 VL14
2713719.CO *19* € 57,68 VL16	2713719.CO *19* € 57,68 VL16	2713719.CO *19* € 57,68 VL16	2713719.CO *19* € 57,68 VL16	2713719.CO *19* € 57,68 VL16	2713719.CO *19* € 57,68 VL16	-	-
55 9002 € 189,75	55 9002 € 189,75	55 9002 € 189,75	55 9002 € 189,75	55 9002 € 189,75	55 9002 € 189,75	-	-
5514689 € 318,50	5514689 € 318,50	5514689 € 318,50	5514691 € 328,50 5515001 € 350,00	5514691 € 328,50 5515001 € 350,00	5514689 € 318,50	5514690 € 328,50 5515002 € 350,00	5514690 € 328,50 5515002 € 350,00

73 - Crankcase MODIFICATIONS: BORING - WE SUGGEST TO USE bearings 6614105EA

79 - Crankcase MODIFICATIONS: BORING - TO COUPLE ONLY with Multivar 5112800 or 5115823



MHR[®]

MALOSSİ HYPER RACING

Scooter 50

with ENGINE 

PIAGGIO

QUARTZ

SFERA
RETYLINGTYPHOON
2007->2010TYPHOON
euro 2
2011->

(C421M)

50 2T

LC

50 2T















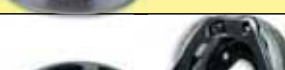





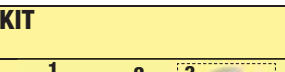
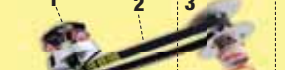

50 2T

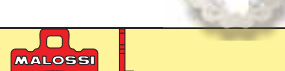

50 2T

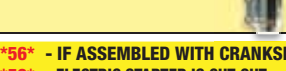
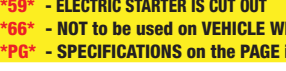

	MULTIVAR VARIATOR	51 8648 € 68,00	51 8648 € 68,00	-	-
	MULTIVAR TEAM VARIATOR	5112645 € 77,25	5112645 € 77,25	5112645 € 77,25	5112645 € 77,25
	X K BELT BELT	61 7665 € 25,68	61 7665 € 25,68	6114118 € 38,25	61 9535 € 28,72
	VENTILVAR HALF-PULLEY	6113416B *59* € 36,72	6113416B *59* € 36,72	6113416B *59* € 36,72	6113416B *59* € 36,72
	TORSION CONTROLLER ANTIFRICTION FIFTH WHEEL	2512828 € 4,45	2512828 € 4,45	2512828 € 4,45	2512828 € 4,45
	TORQUE DRIVER MOBILE DRIVEN SPLIT PULLEY	61 8233 € 85,57	61 8233 € 85,57	61 9100 € 85,57	61 9100 € 85,57
	DELTA CLUTCH ADJUSTABLE CLUTCH	52 7880 € 77,89	52 7880 € 77,89	52 7880 € 77,89	52 7880 € 77,89
	WING CLUTCH BELL CLUTCH BELL (FINNED RING)	7714147 € 90,00 Ø 107	7714147 € 90,00 Ø 107	7714147 € 90,00 Ø 107	7714147 € 90,00 Ø 107
	DELTA SYSTEM MHR BELL + ADJUSTABLE CLUTCH	5214738 € 156,00	5214738 € 156,00	5214738 € 156,00	5214738 € 156,00
	ROLLER CRANKCASE GEAR-BOX COVERS	-	-	2514521 *66* € 95,00	-
	ROLLER CRANKCASE TEAM GEAR-BOX COVERS	-	-	2514603 *66* € 95,00	-
	PINWHEEL SHAFT	-	-	6714530 € 66,30	6714530 € 66,30
	GEARS HTQ PRIMARY	-	-	-	6711602 € 69,34 z 14/48
	GEARS HTQ (PIAGGIO) PRIMARY	67 8727 € 57,67 z 16/37	67 8726 € 71,11 z 15/38	67 9080 z 14/39 € 60,41 6713339 z 15/38 € 61,71	-
	COUPLING Ø 18	67 7385 € 56,53 z 16/37	-	-	-
	GEARS HTQ SECONDARY	-	67 9966 *PG* € 65,00 z 13/48	67 9966 € 65,00 z 13/48	-
	PRESSED COUPLING Ø 17	-	67 8938 *PG* € 60,41 z 13/48	-	-
	SPLINED COUPLING Ø 17	67 8717 *PG* € 59,22 z 14/47	-	-	-
	COUPLING Ø 18	-	-	-	-
	SECOND ROLLER GEAR (COUPLING)	-	67 9967 *PG* € 71,36 z 13/48 (17)	67 9967 € 71,36 z 13/48 (17)	-
KIT	OVER RANGE / OVER RANGE ALUMINUM	6114215 € 253,98	6114215 € 253,98	6114219 262,65 € 365,00	-
	1 MULTIVAR / ALUMINUM VARIATOR	5112645 € 77,25	5112645 € 77,25	5112645 € 77,25 5115644 € 87,55	5112645 € 77,25 5115644 € 87,55
	2 X K BELT BELT	6114114 € 38,76	6114114 € 38,76	6114118 € 38,25	-
	2 X K BELT TEAM / ALUMINUM	6114117 € 40,67	6114117 € 40,67	6115668 € 44,88	-
	3 REAR PULLEY SYSTEM / ALUMINUM REAR PULLEY	6112110 € 163,82	6112110 € 163,82	6113101 € 174,40 6114582 € 275,31	6113101 € 174,40 6114582 € 275,31
	WHOO DISC FRONT BRAKE DISC	-	6212604 € 76,38	6212603 € 72,56	-
	WHOO DISC REAR BRAKE DISC	-	-	-	-
	BRAKE PADS MHR ORGANIC BRAKE PADS	FRONT 62 9088 € 6,55 1992->	-	6215080 € 6,00	6215079 € 8,20
	BRAKE PADS MHR SYNT SINTERED BRAKE PADS	FRONT -	-	6215007 € 11,96	6215013 € 16,50
	BRAKE PADS MHR ORGANIC BRAKE PADS	REAR -	-	-	-
	BRAKE PADS MHR SYNT SINTERED BRAKE PADS	REAR -	-	-	-
	RADIATOR / RADIATOR TEAM	-	-	-	-
	RS24/10 - RS24/10-R FRONT SHOCK ABSORBER	46 8298 € 357,00 4614236 € 428,49	-	-	-
	RS24/10 - RS24/10-R REAR SHOCK ABSORBER	4614237 € 428,82	4614237 € 428,82	-	-
	RS24/10-R FRONT + REAR	4614479 € 814,98	-	-	-

56 - IF ASSEMBLED WITH CRANKSHAFTS 5313275 (5312810-5316048), USE 2015832 € 40,17

59 - ELECTRIC STARTER IS CUT OUT

66 - NOT to be used on VEHICLE WITH ORIGINAL PRIMARY GEARS

PG - SPECIFICATIONS on the PAGE indicated in the TITLE of the LINE

PIAGGIO					VESPA	YAMAHA		
ZIP <-1999	ZIP 2000->	ZIP Fast Rider	ZIP SP <-2000	ZIP SP 2001->	ET2 <-1999	AEROX euro 0-1	AEROX euro 2	
50 2T	50 2T	50 2T	50 2T	50 2T	50 2T	50 2T	50 2T	50 2T
			LC	LC		LC	LC	LC
51 8648 € 68,00	-	51 8648 € 68,00	51 8648 € 68,00	-	51 8648 € 68,00	5113161 € 78,28	5113161 € 78,28	
-	5112645 € 77,25	5112645 € 77,25	5112645 € 77,25	5112645 € 77,25	5112645 € 77,25	-	-	
61 7229 € 20,24	6114114 € 38,76	61 7665 € 25,68	61 7665 € 25,68	6114114 € 38,76	61 7665 € 25,68 6114114 € 38,76	6112729 € 25,23	6112729 € 25,23	
-	6113416B *59* € 36,72	6113416B *59* € 36,72	6113416B *59* € 36,72	6113416B *59* € 36,72	6113416B *59* € 36,72	61 7152 € 21,71	61 7152 € 21,71	
-	2512828 € 4,45	2512828 € 4,45	2512828 € 4,45	2512828 € 4,45	2512828 € 4,45	2512827 € 4,45	2512827 € 4,45	
-	61 9100 € 85,57	61 8233 € 85,57	61 8233 € 85,57	61 9100 € 85,57	61 8233 € 85,57	61 8312 (Ø 33) € 85,57 61 9223 (Ø 34) € 85,57	61 8312 (Ø 33) € 85,57 61 9223 (Ø 34) € 85,57	
-	52 7880 € 77,89	52 7880 € 77,89	52 7880 € 77,89	52 7880 € 77,89	52 7880 € 77,89	52 9451 € 77,89	52 9451 € 77,89	
-	7714147 € 90,00 Ø 107	7714147 € 90,00 Ø 107	7714147 € 90,00 Ø 107	7714147 € 90,00 Ø 107	7714147 € 90,00 Ø 107	7714313 € 90,00 Ø 107	7714313 € 90,00 Ø 107	
-	5214738 € 156,00	5214738 € 156,00	5214738 € 156,00	5214738 € 156,00	5214738 € 156,00	5214739 € 156,00	5214739 € 156,00	
-	2514521 *66* € 95,00	-	-	2514521 *66* € 95,00	-	2515482 € 95,00	2515482 € 95,00	
-	2514603 *66* € 95,00	-	-	2514603 *66* € 95,00	-	-	-	
-	6714530 € 66,30	-	-	6714530 € 66,30	-	6714748 € 60,18	6714748 € 60,18	
-	6711449 z 16/37 € 60,41 6713339 z 15/38 € 61,71	-	-	6711449 z 16/37 € 60,41 6713339 z 15/38 € 61,71	-	6714039 € 57,67 z 13/44	6714039 € 57,67 z 13/44	
-	-	67 8727 € 57,67 z 16/37	67 8727 € 57,67 z 16/37	-	67 8726 € 71,11 z 15/38	-	-	
-	-	67 7385 € 56,53 z 16/37	-	-	-	-	-	
-	67 9968 € 61,65 z 14/47	-	67 9968 *PG* € 61,65 z 14/47	67 9968 € 61,65 z 14/47	67 9968 *PG* € 61,65 z 14/47	6714774 z 15/42 € 67,32 6714775 z 14/43 € 67,32	6714774 z 15/42 € 67,32 6714775 z 14/43 € 67,32	
-	-	-	67 8939 *PG* € 60,41 z 14/47	-	67 8939 *PG* € 60,41 z 14/47	-	-	
67 8717 *PG* € 59,22 z 14/47 <-1995	-	-	-	-	-	-	-	
67 9969 *PG* € 71,36 z 14/47 (17)	67 9969 € 71,36 z 14/47 (17)	-	67 9969 *PG* € 71,36 z 14/47 (17)	67 9969 € 71,36 z 14/47 (17)	67 9969 *PG* € 71,36 z 14/47 (17)	-	-	
-	6114220 € 262,65 6115780 € 365,00	6114215 € 253,98	6114215 € 253,98	6114220 € 262,65 6115780 € 365,00	6114215 € 253,98	6112811 € 272,85 6115821 € 365,00	6112811 € 272,85 6115821 € 365,00	
-	5112645 € 77,25 5115644 € 87,55	5112645 € 77,25	5112645 € 77,25	5112645 € 77,25 5115644 € 87,55	5112645 € 77,25	5112800 € 87,55 5115823 € 88,60 (*56*)	5112800 € 87,55 5115823 € 88,60 (*56*)	
-	6114114 € 38,76	6114114 € 38,76	6114114 € 38,76	6114114 € 38,76	6114114 € 38,76	6114116 € 38,25	6114116 € 38,25	
-	6114117 € 40,67 6115104 € 45,41	6114117 € 40,67	6114117 € 40,67	6114117 € 40,67 6115104 € 45,41	6114117 € 40,67	6115822 € 44,88	6115822 € 44,88	
-	6113101 € 174,40 6114582 € 275,31	6112110 € 163,82	6112110 € 163,82	6113101 € 174,40 6114582 € 275,31	6112110 € 163,82	61 9733 € 170,82 6114590 € 275,31	61 9733 € 170,82 6114590 € 275,31	
-	-	6214097 € 62,00 1993->	6212604 € 76,38 1996->	6212604 € 76,38	6212604 € 76,38 1997->	6213292 € 72,56	6213292 € 72,56	
-	-	-	-	-	-	-	-	
-	-	6215080 € 6,00 1993->	6215074 € 6,30 1996->	6215074 € 6,30	6215074 € 6,30 1997->	62 9083 € 6,20 1997->	62 9083 € 6,20	
-	-	6215007 € 11,96 1993->	6215006 € 11,96 1996->	6215006 € 11,96	6215006 € 11,96 1997->	6215008 € 11,96 1997->	6215008 € 11,96	
-	-	-	-	-	-	-	-	
-	-	-	-	-	-	-	-	
-	-	-	7115506 <-2000 € 177,00 7115430 € 634,00	7115508 2001-> € 183,00 7115431 € 626,00	-	-	-	
-	-	-	46 8298 € 357,00 4614236 € 428,49	46 8298 € 357,00 4614236 € 428,49	-	-	-	
4614237 € 428,82	4614237 € 428,82	4614237 € 428,82	4614237 € 428,82	4614237 € 428,82	4614237 € 428,82	4613081 € 524,44	4613081 € 524,44	
-	-	-	4614479 € 814,98	4614479 € 814,98	-	-	-	



Scooter 50

with ENGINE

YAMAHA

AXIS

BREEZE

BW'S
euro 0-1BW'S
euro 2

(A137E)

50 2T



50 2T



50 2T



50 2T



TEAM Cylinder and crankshaft MUST BE INSTALLED AS A WHOLE

	CYLINDER+HEAD Ø 40 (pin)	31 8403 1 € 184,06 (10)	31 8403 1 € 184,06 (10)	31 8565 1 € 190,84 (10)	31 8565 1 € 190,84 (10)
	CYLINDER+HEAD Ø 47-47,6 (pin)	31 8440 € 267,15 Ø 47,6 (12)	31 8440 € 267,15 Ø 47,6 (12)	31 7559 1 € 251,89 Ø 47 (10)	31 7559 1 € 251,89 Ø 47 (10)
	CYLINDER+HEAD Ø 47,6 (pin)	-	-	-	-
	CRANKSHAFTS RHQ PIN Ø 12 STROKE 39 mm CONNECTING ROD 80	53 8009 € 175,50	53 8009 € 175,50	53 8008 € 163,04	53 8008 € 163,04
	CYLINDER+HEAD Ø 40 TEAM	-	-	-	-
	CYLINDER+HEAD Ø 47,6 TEAM - TEAM 2 STROKE 39 mm C.ROD 80 - 85	-	-	-	-
	CYLINDER+HEAD Ø 50 BIG BORE STROKE 39 mm C.ROD 85	-	-	-	-
	CRANKSHAFTS RHQ PIN Ø 12 STROKE 39 mm C.ROD 85 - 80	-	-	-	-
	CRANKSHAFTS RHQ PIN Ø 12 - 13 TEAM STROKE 39 mm C.ROD 85 - 80	-	-	-	-
	CYLINDER+HEAD Ø 50 BIG BORE STROKE 44 mm C.ROD 85	-	-	-	-
	CRANKSHAFTS RHQ PIN Ø 13 BIG BORE STROKE 44 mm C.ROD 85	-	-	-	-
	CYLINDER+HEAD Ø 52 BIG BORE testa rossa STROKE 44 mm C.ROD 90	-	-	-	-
	CRANKSHAFTS RHQ PIN Ø 13 TEAM STROKE 44 mm C.ROD 90	-	-	-	-
	RADIAL ROLLER BEARING Pg. 473	PG.473	PG.473	PG.473	PG.473
	EXHAUST SYSTEM SCOOTER RACING Ø 40	-	-	-	-
	EXHAUST SYSTEM SCOOTER RACING Ø 47 - 47,6	32 7562 € 266,00	32 7562 € 266,00	32 7561 € 272,00	32 7561 € 272,00
	EXHAUST SYSTEM SCOOTER RACING Ø 47,6 TEAM 2	3214763 € 366,18	3214763 € 366,18	-	-
	EXHAUST SYSTEM SCOOTER RACING Ø 47,6 TEAM 3	-	-	-	-
	EXHAUST SYSTEM SCOOTER RACING Ø 50 BIG BORE 2 Ø 50 STROKE 39 - 44 mm	-	-	-	-
	EXHAUST SYSTEM SCOOTER RACING Ø 52 BIG BORE Ø 52 STROKE 44 mm	-	-	-	-
	CARBURETTOR KIT PHBG Ø 19	1611021 € 129,40	1611021 € 129,40	1611021 € 129,40	1611021 € 129,40
	PHBG Ø 19 TEAM	-	-	-	-
	PHBG Ø 21 TEAM	-	-	-	-
	PHBL Ø 25	1611013 € 217,38	1611013 € 217,38	1611011 € 214,11	1611011 € 214,11
	VHST Ø 28 TEAM	1614022 € 251,86	1614022 € 251,86	-	-
	INTAKE MANIFOLDS Ø 22 x 24,5 RUBBER NBR	0213222B € 52,50	0213222B € 52,50	-	-
	RUBBER FKM	0213661B € 65,10	0213661B € 65,10	-	-
	INTAKE MANIFOLDS Ø 22 x 28 RUBBER NBR	02 8857B € 52,50	02 8857B € 52,50	-	-
	RUBBER FKM	0213662B € 65,10	0213662B € 65,10	-	-
	INTAKE MANIFOLDS X360 Ø 22 x 24,5 RUBBER FKM	2014524 € 52,02	2014524 € 52,02	-	-
	Ø 22 x 28 RUBBER FKM	2014525 € 52,02	2014525 € 52,02	-	-
	Ø 30 x 35 RUBBER FKM	2013847 € 52,02	2013847 € 52,02	-	-
	REED VALVE CARBON FIBRE	2711817.C0 € 52,25 VL14	2711817.C0 € 52,25 VL14	27 7441.C0 € 46,02 VL10	27 7441.C0 € 46,02 VL10
	REED VALVE TEAM	-	-	-	-
	DIGITRONIC EPROM ELECTRONIC DIGITAL CONTROLLER	-	-	-	-
	INNER ROTOR IGNITION TEAM	5514690 € 328,50 5515002 € 350,00	5514690 € 328,50 5515002 € 350,00	5514690 € 328,50 5515002 € 350,00	5514690 € 328,50 5515002 € 350,00

79 - Crankcase MODIFICATIONS: BORING - TO COUPLE ONLY with Multivar 5112800 or 5115823



MHR[®]

MALOSSİ HYPER RACING

Scooter 50

with ENGINE 

YAMAHA

AXIS

BREEZE

BW'S
euro 0-1BW'S
euro 2

50 2T



50 2T

















50 2T



50 2T

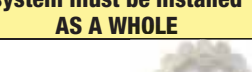
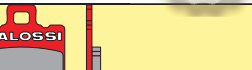

(A137E)

	MULTIVAR VARIATOR	5113161 € 78,28	5113161 € 78,28	5113161 € 78,28	5113161 € 78,28
	MULTIVAR TEAM VARIATOR	-	-	-	-
	X K BELT BELT	6112742 € 26,33	6112742 € 26,33	6112729 € 25,23	6112729 € 25,23
	VENTILVAR HALF-PULLEY	61 7152 € 21,71	61 7152 € 21,71	61 7152 € 21,71	61 7152 € 21,71
	TORSION CONTROLLER ANTIFRICTION FIFTH WHEEL	2512827 € 4,45	2512827 € 4,45	2512827 € 4,45	2512827 € 4,45
	TORQUE DRIVER MOBILE DRIVEN SPLIT PULLEY	61 8312 € 85,57	61 8312 (Ø 33) € 85,57 61 9223 (Ø 34) € 85,57	61 8312 (Ø 33) € 85,57 61 9223 (Ø 34) € 85,57	6112766 € 83,89
	DELTA CLUTCH ADJUSTABLE CLUTCH	52 7879 € 77,89	52 7879 € 77,89	52 7643 (Ø 105) € 77,89 52 9451 (Ø 107) € 77,89	52 7880 € 77,89
	WING CLUTCH BELL CLUTCH BELL (FINNED RING)	-	-	7714313 € 90,00 Ø 107	7714313 € 90,00 Ø 107
	DELTA SYSTEM MHR BELL + ADJUSTABLE CLUTCH	-	-	5214739 € 156,00	-
	ROLLER CRANKCASE GEAR-BOX COVERS	-	-	2515482 € 95,00	2515482 € 95,00
	ROLLER CRANKCASE TEAM GEAR-BOX COVERS	-	-	-	-
	PINWHEEL SHAFT	-	-	6714748 € 60,18	6714748 € 60,18
	GEARS HTQ PRIMARY	67 7324 € 67,90 z 17/40	67 7014 € 68,44 z 15/41	67 3677 € 57,67 z 16/40	67 3677 € 57,67 z 16/40
	GEARS HTQ (PIAGGIO) PRIMARY	-	-	-	-
	COUPLING Ø 17	-	-	-	-
	COUPLING Ø 18	-	-	-	-
	GEARS HTQ SECONDARY	-	-	-	-
	PRESSED COUPLING Ø 17	-	-	-	-
	PG. 478	-	-	-	-
	SPLINED COUPLING Ø 17	-	-	-	-
	COUPLING Ø 18	-	-	-	-
	SECOND ROLLER GEAR (COUPLING)	-	-	-	-
KIT	OVER RANGE / OVER RANGE ALUMINUM	6112812 € 272,85 6116249 € 365,00	6112812 € 272,85 6116249 € 365,00	6112811 € 272,85 6115821 € 365,00	6112811 € 272,85 6115821 € 365,00
	1 MULTIVAR / ALUMINUM VARIATOR	5112800 € 87,55 5115823 € 88,60	5112800 € 87,55 5115823 € 88,60	5112800 € 87,55 5115823 € 88,60	5112800 € 87,55 5115823 € 88,60
	2 X K BELT BELT	6111108 € 27,80	6111108 € 27,80	6114116 € 38,25	6114116 € 38,25
	2 X K BELT TEAM / ALUMINUM	-	-	6115822 € 44,88	6115822 € 44,88
	3 REAR PULLEY SYSTEM / ALUMINUM REAR PULLEY	6111121 € 169,52 6115991 € 275,31	6111121 € 169,52 6115991 € 275,31	61 9733 € 170,82 6114590 € 275,31	61 9733 € 170,82 6114590 € 275,31
	WHOOP DISC FRONT BRAKE DISC	-	6214097 € 62,00 1994->	-	62 8961 € 73,03
	WHOOP DISC REAR BRAKE DISC	-	-	-	-
	BRAKE PADS MHR ORGANIC BRAKE PADS	FRONT 62 9084 € 6,90 1993->	6215080 € 6,00 1994->	6215080 € 6,00 1995->	6215080 € 6,00
	BRAKE PADS MHR SYNT SINTERED BRAKE PADS	FRONT -	6215007 € 11,96 1994->	6215007 € 11,96 1995->	6215007 € 11,96
	BRAKE PADS MHR ORGANIC BRAKE PADS	REAR -	-	-	-
	BRAKE PADS MHR SYNT SINTERED BRAKE PADS	REAR -	-	-	-
	RADIATOR / RADIATOR TEAM	-	-	-	-
	RS24/10 - RS24/10-R FRONT SHOCK ABSORBER	-	-	-	-
	RS24/10 - RS24/10-R REAR SHOCK ABSORBER	-	-	-	-
	RS24/10-R FRONT + REAR	-	-	-	-

56 - IF ASSEMBLED WITH CRANKSHAFTS 5313275 (5312810-5316048), USE 2015832 € 40,17

YAMAHA

BW'S NG euro 0-1	BW'S NG euro 2	BW'S Original/ Naked euro 2 2010->	CRZ	JOG	JOG ER	JOG R	JOGRR euro 2
	(A137E)	(A137E)					
50 2T	50 2T	50 2T	50 2T	50 2T	50 2T	50 2T	50 2T
5113161 € 78,28	5113161 € 78,28	5113161 € 78,28	5113161 € 78,28	5113161 € 78,28	5113161 € 78,28	5113161 € 78,28	5113161 € 78,28
-	-	-	-	-	-	-	-
6112729 € 25,23	6112729 € 25,23	6112729 € 25,23	6112742 € 26,33	6112742 € 26,33	6112742 € 26,33	6112729 € 25,23	6112729 € 25,23
61 7152 € 21,71	61 7152 € 21,71	61 7152 € 21,71	61 7152 € 21,71	61 7152 € 21,71	61 7152 € 21,71	61 7152 € 21,71	61 7152 € 21,71
2512827 € 4,45	2512827 € 4,45	2512827 € 4,45	2512827 € 4,45	2512827 € 4,45	2512827 € 4,45	2512827 € 4,45	2512827 € 4,45
61 8312 (Ø 33) € 85,57 61 9223 (Ø 34) € 85,57	6112766 € 83,89	6112766 € 83,89	61 8312 € 85,57	61 8312 (Ø 33) € 85,57 61 9223 (Ø 34) € 85,57	61 8312 (Ø 33) € 85,57 61 9223 (Ø 34) € 85,57	61 8312 (Ø 33) € 85,57 61 9223 (Ø 34) € 85,57	61 8312 (Ø 33) € 85,57 61 9223 (Ø 34) € 85,57
52 7643 (Ø 105) € 77,89 52 9451 (Ø 107) € 77,89	52 7880 € 77,89	52 7880 € 77,89	52 7643 € 77,89	52 7643 (Ø 105) € 77,89 52 9451 (Ø 107) € 77,89	52 7643 (Ø 105) € 77,89 52 9451 (Ø 107) € 77,89	52 9451 € 77,89	52 9451 € 77,89
7714313 € 90,00 Ø 107	7714313 € 90,00 Ø 107	7714313 € 90,00 Ø 107	-	7714313 € 90,00 Ø 107	7714313 € 90,00 Ø 107	7714313 € 90,00 Ø 107	7714313 € 90,00 Ø 107
5214739 € 156,00	-	-	-	5214739 € 156,00	5214739 € 156,00	5214739 € 156,00	5214739 € 156,00
2515482 € 95,00	2515482 € 95,00	2515482 € 95,00	-	-	-	2515482 € 95,00	2515482 € 95,00
-	-	-	-	-	-	-	-
6714748 € 60,18	6714748 € 60,18	6714748 € 60,18	-	-	-	6714748 € 60,18	6714748 € 60,18
67 3677 € 57,67 z 16/40	67 3677 € 57,67 z 16/40	67 3677 € 57,67 z 16/40	-	67 7324 € 67,90 z 17/40	67 7324 € 67,90 z 17/40	6714039 € 57,67 z 13/44	6714039 € 57,67 z 13/44
-	-	-	-	-	-	-	-
-	-	-	-	-	-	-	-
-	-	-	-	-	-	6714774 z 15/42 € 67,32 6714775 z 14/43 € 67,32	6714774 z 15/42 € 67,32 6714775 z 14/43 € 67,32
-	-	-	-	-	-	-	-
-	-	-	-	-	-	-	-
6112811 € 272,85 6115821 € 365,00	6112811 € 272,85 6115821 € 365,00	6112811 € 272,85 6115821 € 365,00	-	6112812 € 272,85 6116249 € 365,00	6112812 € 272,85 6116249 € 365,00	6112811 € 272,85 6115821 € 365,00	6112811 € 272,85 6115821 € 365,00
5112800 € 87,55 5115823 € 88,60	5112800 € 87,55 5115823 € 88,60	5112800 € 87,55 5115823 € 88,60	-	5112800 € 87,55 5115823 € 88,60	5112800 € 87,55 5115823 € 88,60	5112800 € 87,55 5115823 € 88,60	5112800 € 87,55 5115823 € 88,60 (*56*)
6114116 € 38,25	6114116 € 38,25	6114116 € 38,25	-	6111108 € 27,80	6111108 € 27,80	6114116 € 38,25	6114116 € 38,25
6115822 € 44,88	6115822 € 44,88	6115822 € 44,88	-	-	-	6115822 € 44,88	6115822 € 44,88
61 9733 € 170,82 6114590 € 275,31	61 9733 € 170,82 6114590 € 275,31	61 9733 € 170,82 6114590 € 275,31	-	6111121 € 169,52 6115991 € 275,31	6111121 € 169,52 6115991 € 275,31	61 9733 € 170,82 6114590 € 275,31	61 9733 € 170,82 6114590 € 275,31
62 8961 € 73,03 1995->	62 8961 € 73,03	62 8961 € 73,03	6214097 € 62,00 1992->	-	-	6212603 € 72,56 1993->	-
-	-	-	-	-	-	-	-
6215080 € 6,00 1995->	6215080 € 6,00	6215080 € 6,00	62 9084 € 6,90 1992->	62 9084 € 6,90 1993->	62 9084 € 6,90 1993->	62 9083 € 6,20 1993->	-
6215007 € 11,96 1995->	6215007 € 11,96	6215007 € 11,96	-	-	-	6215008 € 11,96 1993->	-
-	-	-	-	-	-	-	-
-	-	-	-	-	-	-	-
-	-	-	-	-	-	-	-
-	-	-	-	-	-	-	-
-	-	-	-	-	-	-	-
-	-	-	-	-	-	-	-

SCOOTER 2T MHR



Scooter 50

with ENGINE

YAMAHA

NEO'S

SLIDER

SPY

WHY

50 2T

€ 184,06 (10)

50 2T

€ 190,84 (10)

50 2T

€ 190,84 (10)















50 2T

€ 184,06 (10)

TEAM Cylinder and crankshaft MUST BE INSTALLED AS A WHOLE

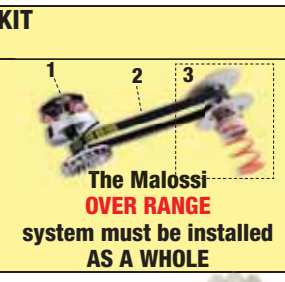
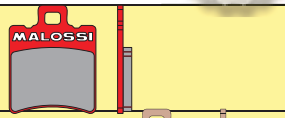
	CYLINDER+HEAD Ø 40 (pin)	31 8403 1 € 184,06 (10)	31 8565 1 € 190,84 (10)	31 8565 1 € 190,84 (10)	31 8403 1 € 184,06 (10)
	CYLINDER+HEAD Ø 47-47,6 (pin)	31 8440 € 267,15 Ø 47,6 (12)	31 7559 1 € 251,89 Ø 47 (10)	31 7559 1 € 251,89 Ø 47 (10)	31 8440 € 267,15 Ø 47,6 (12)
	CYLINDER+HEAD Ø 47,6 (pin)	-	-	-	-
	CRANKSHAFTS RHQ PIN Ø 12 STROKE 39 mm CONNECTING ROD 80	53 8009 € 175,50	53 8008 € 163,04	53 8008 € 163,04	53 8009 € 175,50
	CYLINDER+HEAD Ø 40 TEAM	-	-	-	-
	CYLINDER+HEAD Ø 47,6 TEAM - TEAM 2 STROKE 39 mm C.ROD 80 - 85	-	-	-	-
	CYLINDER+HEAD Ø 50 BIG BORE STROKE 39 mm C.ROD 85	-	-	-	-
	CRANKSHAFTS RHQ PIN Ø 12 STROKE 39 mm C.ROD 85 - 80	-	-	-	-
	CRANKSHAFTS RHQ PIN Ø 12 - 13 TEAM STROKE 39 mm C.ROD 85 - 80	-	-	-	-
	CYLINDER+HEAD Ø 50 BIG BORE STROKE 44 mm C.ROD 85	-	-	-	-
	CRANKSHAFTS RHQ PIN Ø 13 BIG BORE STROKE 44 mm C.ROD 85	-	-	-	-
	CYLINDER+HEAD Ø 52 BIG BORE testa rossa STROKE 44 mm C.ROD 90	-	-	-	-
	CRANKSHAFTS RHQ PIN Ø 13 TEAM STROKE 44 mm C.ROD 90	-	-	-	-
	RADIAL ROLLER BEARING Pg. 473	PG.473	PG.473	PG.473	PG.473
	EXHAUST SYSTEM SCOOTER RACING Ø 40	-	-	-	-
	EXHAUST SYSTEM SCOOTER RACING Ø 47 - 47,6	32 7562 € 266,00	32 7561 € 272,00	32 7561 € 272,00	32 7562 € 266,00
	EXHAUST SYSTEM SCOOTER RACING Ø 47,6 TEAM 2	3214763 € 366,18	-	-	3214763 € 366,18
	EXHAUST SYSTEM SCOOTER RACING Ø 47,6 TEAM 3	-	-	-	-
	EXHAUST SYSTEM SCOOTER RACING Ø 50 BIG BORE 2 Ø 50 STROKE 39 - 44 mm	-	-	-	-
	EXHAUST SYSTEM SCOOTER RACING Ø 52 BIG BORE Ø 52 STROKE 44 mm	-	-	-	-
	CARBURETTOR KIT PHBG Ø 19	1611021 € 129,40	1611021 € 129,40	1611021 € 129,40	1611021 € 129,40
	PHBG Ø 19 TEAM	1611021.T € 202,60	-	-	-
	PHBG Ø 21 TEAM	1613890.TO € 210,60	-	-	-
	PHBL Ø 25	1611013 € 217,38	1611011 € 214,11	1611011 € 214,11	1611013 € 217,38
	VHST Ø 28 TEAM	1614022 € 251,86	-	-	1614022 € 251,86
	INTAKE MANIFOLDS Ø 22 x 24,5 RUBBER NBR	0213222B € 52,50	-	-	0213222B € 52,50
	RUBBER FKM	0213661B € 65,10	-	-	0213661B € 65,10
	INTAKE MANIFOLDS Ø 22 x 28 RUBBER NBR	02 8857B € 52,50	-	-	02 8857B € 52,50
	RUBBER FKM	0213662B € 65,10	-	-	0213662B € 65,10
	INTAKE MANIFOLDS X360 Ø 22 x 24,5 RUBBER FKM	2014524 € 52,02	-	-	2014524 € 52,02
	Ø 22 x 28 RUBBER FKM	2014525 € 52,02	-	-	2014525 € 52,02
	Ø 30 x 35 RUBBER FKM	2013847 € 52,02	-	-	2013847 € 52,02
	REED VALVE CARBON FIBRE	2711817.CO € 52,25 VL14	27 7441.CO € 46,02 VL10	27 7441.CO € 46,02 VL10	2711817.CO € 52,25 VL14
	REED VALVE TEAM	-	-	-	-
	DIGITRONIC EPROM ELECTRONIC DIGITAL CONTROLLER	-	-	-	-
	INNER ROTOR IGNITION	5514690 € 328,50	5514690 € 328,50	5514690 € 328,50	5514690 € 328,50
	INNER ROTOR IGNITION TEAM	5515002 € 350,00	5515002 € 350,00	5515002 € 350,00	5515002 € 350,00

with ENGINE 

	MULTIVAR VARIATOR	5113161 € 78,28	5113161 € 78,28	5113161 € 78,28	5113161 € 78,28
	MULTIVAR TEAM VARIATOR	-	-	-	-
	X K BELT BELT	6112729 € 25,23	6112729 € 25,23	6112729 € 25,23	6112729 € 25,23
	VENTILVAR HALF-PULLEY	61 7152 € 21,71	61 7152 € 21,71	61 7152 € 21,71	61 7152 € 21,71
	TORSION CONTROLLER ANTIFRICTION FIFTH WHEEL	2512827 € 4,45	2512827 € 4,45	2512827 € 4,45	2512827 € 4,45
	TORQUE DRIVER MOBILE DRIVEN SPLIT PULLEY	61 8312 (Ø 33) € 85,57 61 9223 (Ø 34) € 85,57	61 8312 (Ø 33) € 85,57 61 9223 (Ø 34) € 85,57	61 8312 (Ø 33) € 85,57 61 9223 (Ø 34) € 85,57	61 8312 (Ø 33) € 85,57 61 9223 (Ø 34) € 85,57
	DELTA CLUTCH ADJUSTABLE CLUTCH	52 9451 € 77,89	52 9451 € 77,89	52 7643 (Ø 105) € 77,89 52 9451 (Ø 107) € 77,89	52 9451 € 77,89
	WING CLUTCH BELL CLUTCH BELL (FINNED RING)	7714313 € 90,00 Ø 107	7714313 € 90,00 Ø 107	7714313 € 90,00 Ø 107	7714313 € 90,00 Ø 107
	DELTA SYSTEM MHR BELL + ADJUSTABLE CLUTCH	5214739 € 156,00	5214739 € 156,00	5214739 € 156,00	5214739 € 156,00
	ROLLER CRANKCASE GEAR-BOX COVERS	2515482 € 95,00	2515482 € 95,00	-	-
	ROLLER CRANKCASE TEAM GEAR-BOX COVERS	-	-	-	-
	PINWHEEL SHAFT	6714748 € 60,18	6714748 € 60,18	-	-
	GEARS HTQ PRIMARY	6714039 € 57,67 z 13/44	67 3677 € 57,67 z 16/40	67 3677 € 57,67 z 16/40	6714039 € 57,67 z 13/44
	GEARS HTQ (PIAGGIO) PRIMARY COUPLING Ø 17	-	-	-	-
	COUPLING Ø 18	-	-	-	-
	GEARS HTQ SECONDARY PRESSED COUPLING Ø 17	6714774 z 15/42 € 67,32 6714775 z 14/43 € 67,32	-	-	-
	PG. 480 SPLINED COUPLING Ø 17	-	-	-	-
	COUPLING Ø 18	-	-	-	-
	SECOND ROLLER GEAR (COUPLING)	-	-	-	-
KIT	OVER RANGE / OVER RANGE ALUMINUM	6112811 € 272,85 6115821 € 365,00	6112811 € 272,85 6115821 € 365,00	6112811 € 272,85 6115821 € 365,00	6112811 € 272,85 6115821 € 365,00
	1 MULTIVAR / ALUMINUM VARIATOR	5112800 € 87,55 5115823 € 88,60	5112800 € 87,55 5115823 € 88,60	5112800 € 87,55 5115823 € 88,60	5112800 € 87,55 5115823 € 88,60
	2 X K BELT BELT	6114116 € 38,25	6114116 € 38,25	6114116 € 38,25	6114116 € 38,25
	2 X K BELT TEAM / ALUMINUM	6115822 € 44,88	6115822 € 44,88	6115822 € 44,88	6115822 € 44,88
	3 REAR PULLEY SYSTEM / ALUMINUM REAR PULLEY	61 9733 € 170,82 6114590 € 275,31	61 9733 € 170,82 6114590 € 275,31	61 9733 € 170,82 6114590 € 275,31	61 9733 € 170,82 6114590 € 275,31
	WHOOPIE DISC FRONT BRAKE DISC	6212603 € 72,56 1997->	6212603 € 72,56 2000->	62 8961 € 73,03 1996->	-
	WHOOPIE DISC REAR BRAKE DISC	-	-	-	-
	BRAKE PADS MHR ORGANIC BRAKE PADS FRONT	62 9083 € 6,20 1997->	6215080 € 6,00 2000->	6215080 € 6,00 1996->	-
	BRAKE PADS MHR SYNT SINTERED BRAKE PADS FRONT	6215008 € 11,96 1997->	6215007 € 11,96 2000->	6215007 € 11,96 1996->	-
	BRAKE PADS MHR ORGANIC BRAKE PADS REAR	-	-	-	-
	BRAKE PADS MHR SYNT SINTERED BRAKE PADS REAR	-	-	-	-
	RADIATOR / RADIATOR TEAM	-	-	-	-
	RS24/10 - RS24/10-R FRONT SHOCK ABSORBER	-	-	-	-
	RS24/10 - RS24/10-R REAR SHOCK ABSORBER	-	-	-	-
	RS24/10-R FRONT + REAR	-	-	-	-

C-ONE



Crankcase

for all scooters that fit a Piaggio LC 50 cc engine as original equipment

MHR C-ONE was conceived and designed to:

- Fit both drum brake and disc brake.
- Replace the original engine both with short and long wheelbase. The position of the shock absorber fixing has been designed to satisfy both options.
- Install both cylinders with stud bolts and cylinders with flange fixing.
- Use an electric cooling pump to eliminate the power consumption of the traditional mechanical water pump.
- Eliminate the automatic mixer.
- Install the vacuum fuel pump.
- Install the new bigger reed valve, designed using sophisticated programs of 3D fluid-dynamics simulation.
- Hold all current Malossi products.

Malossi is changing the rules of the game and is once again raising the performance level for modern racing scooters.

The result of extreme choices, the C-One housing marks a radical departure from the traditional structure of the scooter it is designed for and finally provides a technically advanced structure that is ready for installation of the latest generation of racing components.

Until now, racing scooters could be fitted only with the original engine housing, designed to withstand a handful of horsepower and adapted to cope with the stress of competition with 70 cubic centimetre engines and about 26 horsepower.

Today, on the other hand, Malossi, the innovation leader, turns the tables, proudly presenting its international public with the C-one motor housing.

Designed and produced in the Malossi facility in Calderara di Reno, one of the most advanced centres for the research, development and production of special parts for motors and scooters, Malossi's dream to produce the most innovative racing parts ever for scooters takes shape in the C-one.

It started with the elimination of automatic mixers and the traditional mechanical water pump to maximize dispersion reduction. They continued, creating the preparation for installation of a rear disk and drum brake system and adding the possibility of using a vacuum fuel pump.

The seat for the reed valve was considerably changed. By taking advantage of all of the possibilities offered by modern 3D fluid dynamics simulation software, Malossi technicians were able to identify the ideal size and dimensions.

As if it had to draw the ideal engine housing on a blank piece of paper, completely detaching itself from the past, Malossi introduced a hole next to the positions in the original housings for stud bolts that can be used by the new creations in the thermal units in the Team Factory family, with flange and short stud attachment. This solution makes it possible to design totally original cylinders. Build a new engine, customize your racing scooter, choose from the Malossi catalogue the most prestigious parts!

We will be ready to provide whatever technical assistance may be needed!





5715844

€ 450,00



57 C-ONE PIAGGIO

Technical features:

- Crankcase pair, die-cast material in aluminum silicon alloy with high mechanical resistance.
- Crankcases inclusive of silent block 5,250 Kg.
- Crankshaft - clutch shaft wheelbase 270 mm.
- Bolt holes wheelbase 48 x 48.
- Crankshaft bearings 20 x 47 x 14.
- Oil seals FKM plus PTFE.
- Reed valve VL 18.
- Intake manifold X360 Ø 21 - 28 l. 27.
- Cylinder stud bolts material: steel 8.8 UNI EN20898/1.
- Fluid connector.
- Wheel axle bearing 20 x 47 x 14.
- Roller gear cover size 16 x 22 x 12.

1616276 € 251,86
CARBURETTOR KIT VHST 28 BS MHR



1313799B € 41,82
FKM INTAKE RUBBER
for Dell'Orto carburettor Ø 28 - 30



C-ONE

Mounting cylinders with stud bolts.

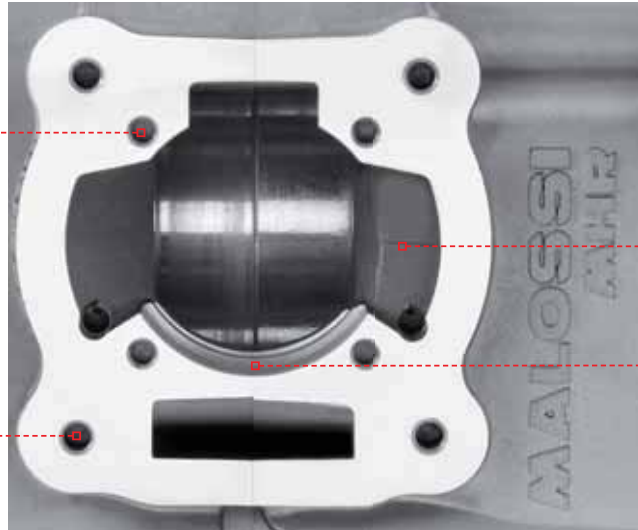

Transfer ports perfectly coupled to the Malossi MHR Team 7 cylinder kits transfer ports.

Cylinder housing boring \varnothing 61 mm.

Cylinder mounting to Malossi flange.

Ready for user with original Malossi roller crankcase 2514603 MHR / original.

Preparation for depression fuel pump.

Ready for use with starter casing cover Gilera Runner 50 2T.

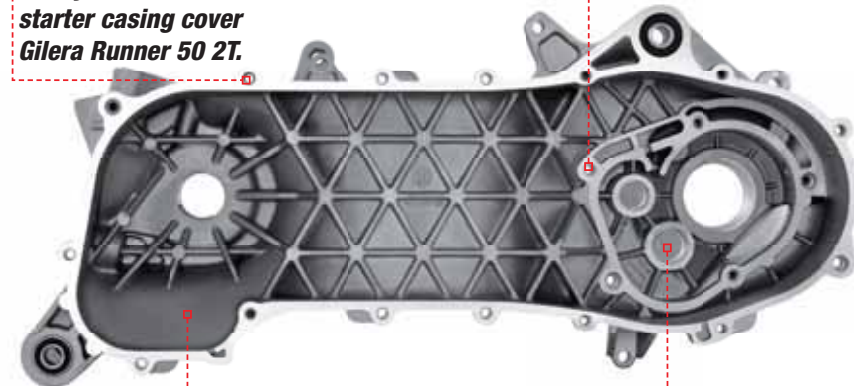

Elimination of automatic mixer.

Larger needle bearing \varnothing 16 x 22 x 12.

Larger single-petal reed valve Malossi VL18.

Ready for brake caliper installation.

Installation slots internal rotor ignition.

Pump casing boring \varnothing 73.

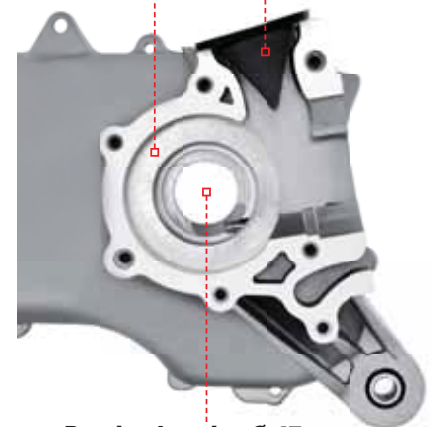
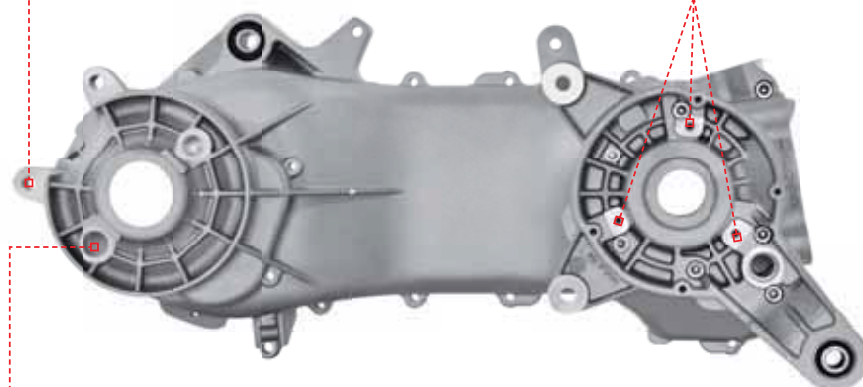

Ready for brake shoe mounting.

Bearing housing \varnothing 47.

Products to be used exclusively for racing in places specially designed for such activity according to the regulations of the competent sporting authorities. We accept no liability resulting from improper use.

C-ONE



youtu.be/ksc1YhJGX8I

Crankcase

for all scooters that fit a

Yamaha Minarelli LC 50 cc engine as original equipment

Malossi has achieved the impossible, uniting the world of racing motors for scooters to the C-One Yamaha-Minarelli.

Our technicians have designed the C-One Yamaha-Minarelli as a platform for bringing together the technical solutions as well as the internal external dimensions with all C-One Malossi models.

Malossi C-One uses the same heating unit and transmissions on all of its models, both for Piaggio and Yamaha/Minarelli scooters, linking two worlds which have always been apart by enhancing and giving value to the best elements of both.

C-One for Yamaha has been designed to be entirely Plug & Play for all scooters equipped with 50cc Yamaha/Minarelli liquidcooled motors: no modifications to the chassis are required, and the internal section can accept all products in the Malossi selection for the RC-One range, becoming a revolutionary solution for the development of racing components for ALL scooters

THE TECHNIQUE

The base of the cylinder has been inclined by 10° compared to the original drive shaft axle - gears.

This innovative development has allowed Malossi technicians to connect the motor attachments in front of the power unit, doing away with one of the biggest Achilles heels once of standard Yamaha/Minarelli motor housings once and for all. A modification underneath the saddle compartment.

The base of the C-One Yamaha-Minarelli requires two different stud mounts in order to house either Malossi cylinders with through-hole studs or flanged mount short studs with 47.6 max. diameter. The advantage of this solution is that it opens the door to entirely unique cylinder designs.

The reed valve mount has been significantly changed thanks to the latest 3D fluid dynamics simulation software, allowing Malossi technicians to find the ideal ratios and dimensions. The automatic mixer and mechanical water pump have been removed to reduce dispersion as much as possible.

The possibility to perform a native install of a Malossi internal ignition rotor has been allowed, as well as a vacuum fuel pump. As for the bike itself, C-One for Yamaha is designed exclusively for scooters with rear disc brakes fitted as standard, and is not designed for the alternative use of brake shoes.

The interaxle spacing has been increased, with a consequential increased stability and precision when taking curves, whereas the gearbox housing has been reduced in size by overlapping the gear wheels. The increased interaxle spacing and the internal diameter means that the starter cover designed for Piaggio scooters is required. All C-One for Yamaha housings are supplied complete with the components required for installation.

Indeed, considering the notable technical differences when compared to standard units, Malossi has decided to include a reed valve, covers, and a special wheel pin in order to use the original rear wheel and make the C-One perfectly interchangeable with Yamaha/Minarelli wheels and hubs.

Another optional is the special rear mudguard to protect and keep the carburettor clean, now positioned at the rear. The new housings have been designed and built in Calderara di Reno at Malossi's new headquarters, one of the most advanced centres for research, development and production of special parts for motors and scooters.

These parts were thought of and produced with one objective: to produce the most innovative racing components for scooters ever.

C-ONE

5716654
€ 477,00

Technical features:

- Crankcase pair, die-cast material in aluminum silicon alloy with high mechanical resistance.
- Crankcases inclusive of bearings 5.150 Kg.
- Crankshaft - clutch shaft wheelbase 270 mm.
- Bolt holes wheelbase 48 x 48.
- Crankshaft bearings 20 x 47 x 14.
- Oil seals FKM plus PTFE.
- Reed valve VL 18.
- Intake manifold X360 I. 27.
- Cylinder stud bolts material: steel 8.8 UNI EN20898/1.
- Oversized cooling fluid connector: external $\tilde{\text{A}}$ 18 mm - internal $\tilde{\text{A}}$ 13,5 mm.
- Wheel axle bearing 20 x 47 x 14.
- Pinwheel.
- Roller gear cover size 16 x 22 x 12.

1616276 € 251,86
CARBURETTOR KIT VHST 28 BS MHR

1313799B € 41,82
FKM INTAKE RUBBER
 for Dell'Orto carburetors \varnothing 28 - 30



Mounting cylinders with stud bolts.

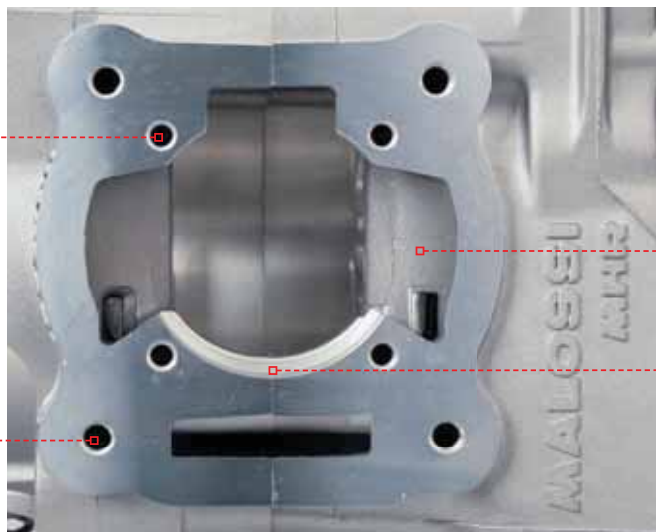

Transfer ports perfectly coupled to the Malossi MHR Team 7 cylinder kits transfer ports.

Cylinder housing boring \varnothing 61 mm.

Cylinder mounting to Malossi flange.

Ready for use with starter casing cover Gilera Runner 50 2T.

Ready for user with original Malossi roller crankcase 2514603 MHR.

Preparation for depression fuel pump.



Elimination of automatic mixer.

Larger needle bearing \varnothing 16 x 22 x 12.

Larger single-petal reed valve Malossi VL18.

Ready for brake caliper installation.

Installation slots internal rotor ignition.

Larger single-petal reed valve Malossi VL18.



Bearing housing \varnothing 47.

RC-ONE



This crankcase has been dreamed of and brought to reality with just one aim in mind: to produce the most innovative racing component for scooters that has ever existed.

Crankcase for all scooters that fit a **Piaggio LC 50 cc engine as original equipment**



5715845
€ 470,00



A revolution cannot be considered as such, if it does not involve a radical change. That's the reason why Malossi decided to go beyond the C-One crankcase, thus realizing RC-One, an even more extreme version dedicated to those who love high-powered engines.

With the release of RC-One crankcase as well as the new MHR Flanged Mount cylinder, the engine capacity achieves 94 ccs and the power largely exceeds 30 hp, without any problems of boring or resistance involving the engine block.

RC-One is designed to use exclusively Malossi cylinder with flanged mount; inside it has a housing of such dimensions as to allow the installation of long-stroke crankshaft without any further modification.

MHR C-ONE was conceived and designed to:

- Fit both drum brake and disc brake.
 - Replace the original engine both with short and long wheelbase.
- The position of the shock absorber fixing has been designed to satisfy both options.
- Fit exclusively the brand-new Malossi MHR Ø 52 Flanged Mount testa rossa cylinder, with flange mounting and a housing of such dimensions as to allow the installation of Malossi RHQ crankshaft with stroke 44 and connecting rod 90, without any further modification.
 - House exclusively the Malossi MHR and MHR TEAM inner rotor ignitions.
 - Use an electric cooling pump to eliminate the power consumption of the traditional mechanical water pump.
 - Eliminate the automatic mixer.
 - Designed to fit the vacuum fuel pump.
 - Install the new bigger reed valve, designed using sophisticated programs of 3D fluid-dynamics simulation.
 - Hold all current Malossi products.



Technical features

- Crankcase pair, die-cast material in aluminum silicon alloy with high mechanical resistance.
- Crankcases inclusive of silent block 5,250 Kg.
- Crankshaft - clutch shaft wheelbase 270 mm.
- Crankshaft bearings 20 x 47 x 14.
- Oil seals FKM plus PTFE.
- Reed valve VL 18.
- Intake manifold X360 Ø 21 - 28 length 27.
- Cylinder stud bolts material: steel 8.8 UNI EN20898/1.
- Oversized cooling fluid connector: external Ø 18 mm - internal Ø 13,5 mm.
- Wheel axle bearing 20 x 47 x 14.
- Roller gear cover size 16 x 22 x 12.



1616276 € 251,86
CARBURETTOR KIT VHST 28 BS MHR



RC-ONE

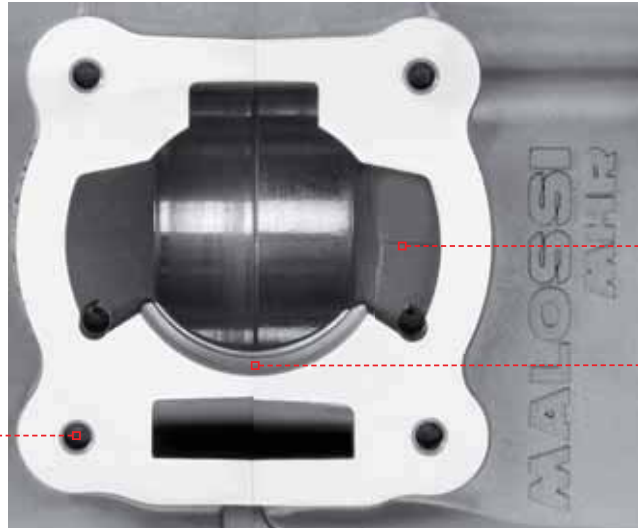

Transfer ports perfectly coupled to the Malossi MHR Team 7 cylinder kits transfer ports.

Cylinder housing boring \varnothing 61 mm.

Installation of Malossi \varnothing 52 MHR Flanged Mount testa rossa cylinders 3115883

Ready for user with original Malossi roller crankcase 2514521 MHR / original.

Ready for use with starter casing cover Gilera Runner 50 2T.

Preparation for depression fuel pump.

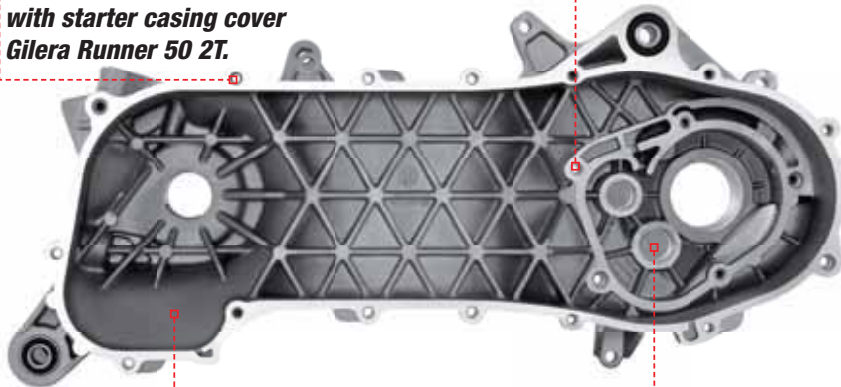

Elimination of automatic mixer.

Larger needle bearing \varnothing 16 x 22 x 12.

Larger single-petal reed valve Malossi VL18.

Pump casing boring \varnothing 78.

Ready for brake caliper installation.

Installation slots internal rotor ignition Malossi 5514691 MHR - 5515001 MHR TEAM.

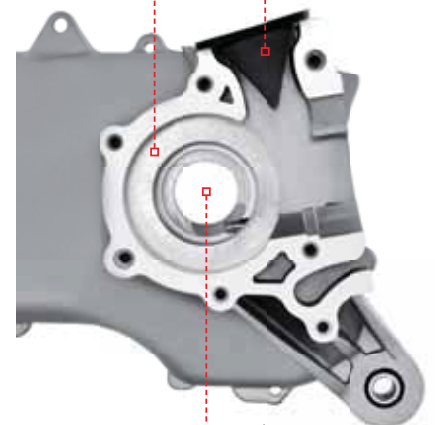
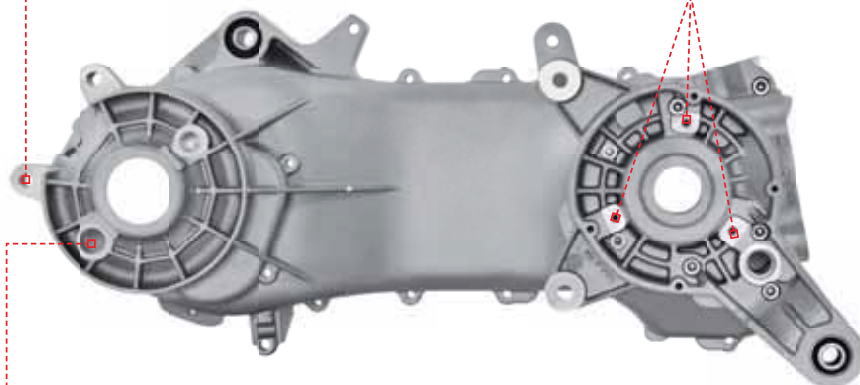

Ready for brake shoe mounting.

Bearing housing \varnothing 47.

Products to be used exclusively for racing in places specially designed for such activity according to the regulations of the competent sporting authorities. We accept no liability resulting from improper use.



94 cc

Supplementary elements



5715845 € 470,00

MHR RC-one
COMPLETE ENGINE CRANKCASE



5316029 € 465,00

CRANKSHAFT MHR TEAM
PIN Ø 13 ROD 90 (STROKE 44)



ATTENTION: This cylinder kit must be installed necessarily with the products displayed in this page.



3115883 € 437,00

CYLINDER KIT Ø 52 MHR
FLANGED MOUNT *testa rossa*

RC-ONE



youtu.be/ksc1YhJGX8I

This crankcase has been dreamed of and brought to reality with just one aim in mind: to produce the most innovative racing component for scooters that has ever existed.

Crankcase

for all scooters that fit a

Yamaha Minarelli LC 50 cc engine as original equipment

5716668

€ 498,00



Malossi has achieved the impossible, uniting the world of racing motors for scooters thanks to the RC-One Yamaha-Minarelli.

Our technicians have designed the RC-One Yamaha-Minarelli as a platform for bringing together the technical solutions as well as the internal external dimensions with all RCOne Malossi models.

The Malossi RC-One housings have been designed to be used only with 94cc Flanged Mount heating units with external studs. The generous pump housing dimensions are finally adequate enough for high capacity engine blocks. Malossi C-One uses the same transmission both for Piaggio and Yamaha/ Minarelli scooters, linking two worlds which have always been apart by enhancing and giving value to the best elements of both.

RC-One for Yamaha has been designed to be entirely Plug & Play for all scooters equipped with 50cc Yamaha/Minarelli liquid-cooled motors: no modifications to the chassis are required, and the internal section can accept all products in the Malossi selection for the RC-One range, becoming a revolutionary solution for the development of racing components for ALL scooters.

THE TECHNIQUE

The base of the cylinder has been inclined by 10° compared to the original drive shaft axle - gears.

This innovative development has allowed Malossi technicians to connect the motor attachments in front of the power unit, doing away with one of the biggest Achilles heels once of standard Yamaha/Minarelli motor housings once and for all. A modification underneath the saddle compartment. The base of the Yamaha RC-One has been designed to only house Malossi cylinders with flange mounts and external studs for the MHR Ø 52 Flanged Mount testa rossa family. The advantages of this solution open the door to the possibility of designing entirely unique cylinders.

The reed valve mount has been significantly changed thanks to the latest 3D fluid dynamics simulation software, allowing Malossi technicians to find the ideal ratios and dimensions. The automatic mixer and mechanical water pump have been removed to reduce dispersion as much as possible. The possibility to perform a native install of a Malossi internal ignition rotor has been allowed. As for the bike itself, RC-One for Yamaha is designed exclusively for scooters with rear disc brakes fitted as standard, and is not designed for the alternative use of brake shoes.

The interaxle spacing has been increased, with a consequential increased stability and precision when taking curves, whereas the gearbox housing has been reduced in size by overlapping the gear wheels. The increased interaxle spacing and the internal diameter means that the starter cover designed for Piaggio scooters is required. All RC-One for Yamaha housings are supplied complete with the components required for installation. Indeed, considering the notable technical differences when compared to standard units, Malossi has decided to include a reed valve, covers, and a special wheel pin in order to use the original rear wheel and make the RC-One perfectly interchangeable with Yamaha/Minarelli wheels and hubs. Another optional is the special rear mudguard to protect and keep the carburettor clean, now positioned at the rear.

The new housings have been designed and built in Calderara di Reno at Malossi's new headquarters, one of the most advanced centres for research, development and production of special parts for motors and scooters. These parts were thought of and produced with one objective: to produce the most innovative racing components for scooters ever.



Technical features:

- Crankcase pair, die-cast material in aluminum silicon alloy with high mechanical resistance.
- Crankcases inclusive of bearings 5.150 Kg.
- Crankshaft - clutch shaft wheelbase 270 mm.
- Crankshaft bearings 20 x 47 x 14.
- Oil seals FKM plus PTFE.
- Reed valve VL 18.
- Intake manifold X360 Ø 21 - 28 length 27.
- Cylinder stud bolts material: steel 8.8 UNI EN20898/1.
- Oversized cooling fluid connector: external Ø 18 mm - internal Ø 13,5 mm.
- Pinwheel.
- Wheel axle bearing 20 x 47 x 14.
- Roller gear cover size 16 x 22 x 12.



1616276 € 251,86
CARBURETTOR KIT VHST 28 BS MHR



RC-ONE

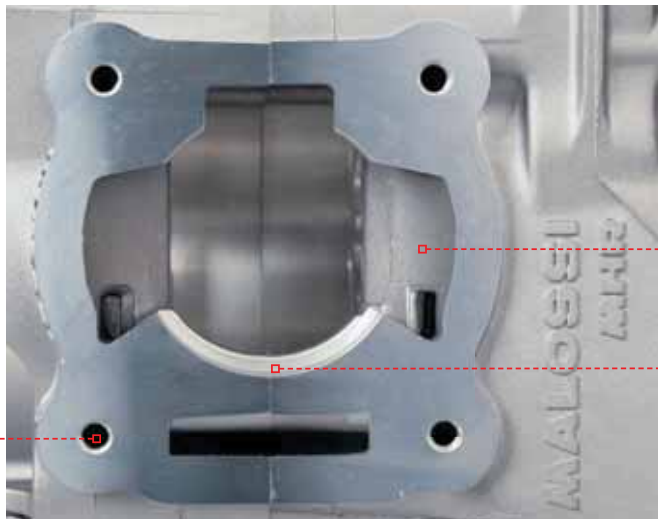

Transfer ports perfectly coupled to the Malossi MHR Team 7 cylinder kits transfer ports.

Cylinder housing boring \varnothing 61 mm.

Installation of Malossi \varnothing 52 MHR Flanged Mount testa rossa cylinders 3115883

Ready for use with starter casing cover Gilera Runner 50 2T.

Ready for user with original Malossi roller crankcase 2514521 MHR / original.

Preparation for depression fuel pump.



Elimination of automatic mixer.

Larger needle bearing \varnothing 16 x 22 x 12.

Larger single-petal reed valve Malossi VL18.

Pump casing boring \varnothing 78.

Ready for brake caliper installation.

Installation slots internal rotor ignition Malossi 5514691 MHR - 5515001 MHR TEAM.

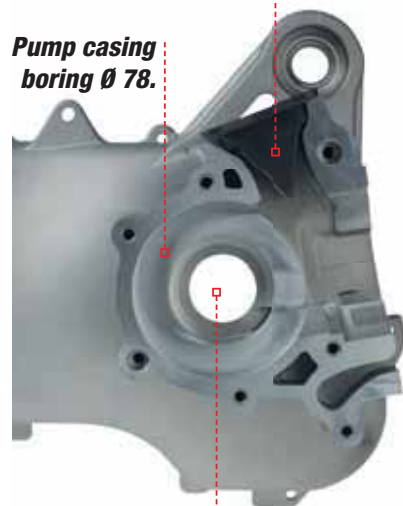

Bearing housing \varnothing 47.

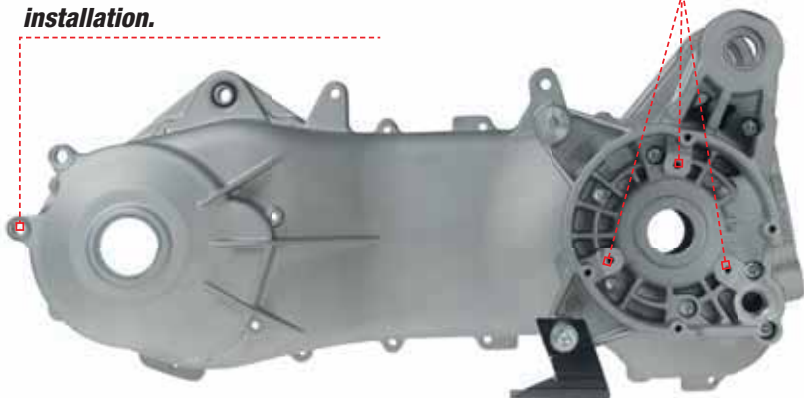

Products to be used exclusively for racing in places specially designed for such activity according to the regulations of the competent sporting authorities. We accept no liability resulting from improper use.



94 cc

Supplementary elements



5716668 € 498,00

MHR RC-one
COMPLETE ENGINE CRANKCASE



5316029 € 465,00

CRANKSHAFT MHR TEAM
PIN Ø 13 ROD 90 (STROKE 44)



ATTENTION: This cylinder kit must be installed necessarily with the products displayed in this page.



3115883 € 437,00

CYLINDER KIT Ø 52 MHR
FLANGED MOUNT *testa rossa*

New
MHR
 MALOSSİ HYPER RACING

AIR FORCE

C/RC-One crankcase cover



**C/RC-One crankcase cover
with kit starter**

5717218

€ 160,00

**C/RC-One crankcase
cover**

5717217

€ 131,50

Filter kit for AIR FORCE



2517260 – € 38,00

The range of Malossi engine crankcases now welcomes a new and precious addition: **Air Force**, the new engine crankcase **compatible with C-One, RC-One and the original Piaggio extended crankcase**.

It's called **Air Force** because its strength lies in the ability of simultaneously allowing entry of a **greater mass of air, channelling it precisely on the transmission components** and increasing the engine's capacity for hot-air extraction. The advantage that comes with this combined ability is a significant reduction in the temperature of the Over Range compartment and consequently, **improved stability and endurance of the transmission**.

Designed for die-casting, thanks to its structure, Air Force **considerably increases the mechanical resistance** of the whole assembly, providing an accurate and dynamic driving experience.

Lastly, its internal conformation frees up **all the space needed in the back area** for the clutch bell, significantly increasing the volume available for the transmission gear while also **greatly reducing the lateral dimensions** compared to the standard engine crankcase.

For Malossi C-ONE / R-C ONE CRANKCASE: 5715844 - 5716654 - 5715845 - 5716668

And original Crankcase Piaggio:

APRILIA	MOJITO CUSTOM 50 2T
	SR (carb.) 50 2T LC 2004-> (PIAGGIO)
	SR MOTARD 50 2T euro 2
	SR R (carb.) 50 2T LC (PIAGGIO)
DERBI	ATLANTIS - BULLET 50 2T 2003->
	GP1 50 2T LC
	GP1 OPEN 50 2T LC
	GP1 REVOLUTION 50 2T LC
GILERA	ICE 50 2T
	RUNNER 50 2T LC
	RUNNER SP 50 2T LC <-2005 / 2006-> (C451M)
	STALKER 50 2T
	TYPHOON X 50 2T

ITALJET	JET SET 50 2T
PIAGGIO	DISIS 50 2T
	FLY 50 2T
	FREE 50 2T 2001->
	NRG EXTREME 50 2T / 2T LC
	NRG MC2 50 2T LC 1998->
	NRG MC3 DD 50 2T LC
	NRG MC3 DT 50 2T
	NRG Power DD 50 2T LC
	NRG Power DT 50 2T (C453M)
	TYPHOON 50 2T 2007->2010
VESPA	Primavera 50 2T euro 2 (C533M)
	Sprint 50 2T euro 2

New



MHR
MALOSSİ HYPER RACING

357

AIR FORCE

**C/RC-One crankcase cover
with kit starter**

5717218

€ 160,00



C/RC-One crankcase cover

5717217

€ 131,50



57 AIR FORCE



New
Cylinder kit
Flanged Mount Testa rossa

3115901 Ø 47,6
€ 402,00
MALOSSI C-one

3115883 Ø 52
€ 437,00
MALOSSI RC-one

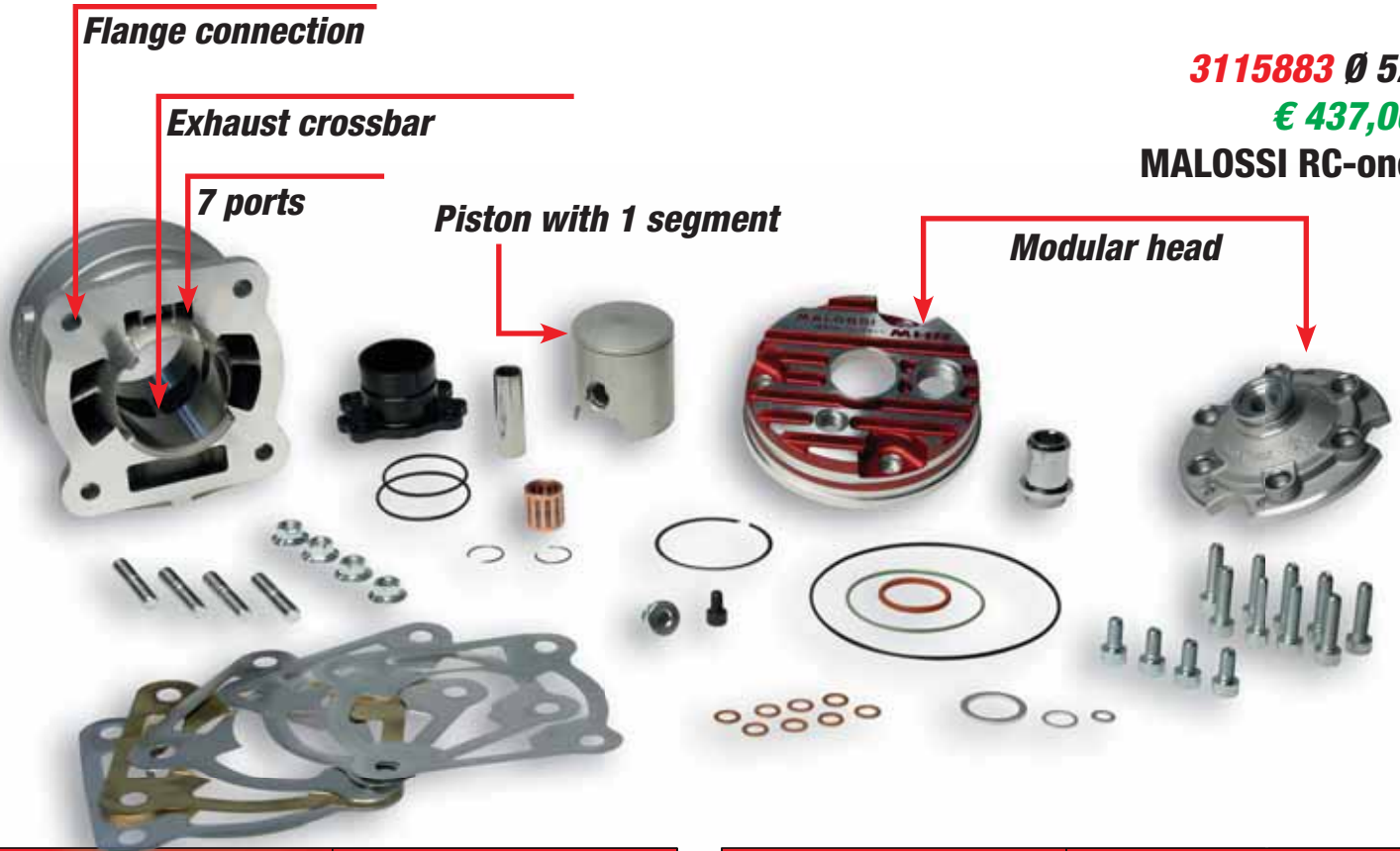

Products to be used exclusively for racing in places specially designed for such activity according to the regulations of the competent sporting authorities. We accept no liability resulting from improper use.

Use	Racing
Power range	21-26 cv @14.300 rpm
Level of compatible elaboration	Racing exhaust system
Ø 47,6	 Shaft connecting rod 85 stroke 39,3 C-One
	 Carburettor Ø 19-28 mm
	 System trasmission OVER RANGE MHR furia rossa
	 HARD

Use	Racing
Power range	29-31 cv @13.800 rpm
Level of compatible elaboration	Racing exhaust system
Ø 52	 Shaft connecting rod 90 stroke 44 RC-One
	 Carburettor Ø 28-34 mm
	 System trasmission OVER RANGE MHR furia rossa
	 HARD

Testa Rossa Flanged Mount 70 cc

Maximum performance, flanged design, only for liquid-cooled scooters (7 ports and exhaust crossbar - piston with 1 segment - modular head - required use of C-One Malossi case - engine shaft with connecting rod different from the original).

Testa Rossa Flanged Mount 94 cc

The most powerful cylinder ever to be produced by Malossi. High capacity, flanged design, only for liquid-cooled scooters (7 ports and exhaust crossbar - piston with 1 segment - modular head - required use of RC-One Malossi case - engine shaft with connecting rod different from the original).

The most advanced production of Malossi cylinders is represented by Flanged Mount cylinders, **designed for Malossi C-One and RC-One engine cases and intended for liquid-cooled scooters only.**

Specifically designed to be used in high level competitions, they feature the latest evolution of the iconic Malossi 7 port technology, the strong point of which is definitely the support given to the main rear ports thanks to the use of the two lights opposite the exhaust, now added to the advantage of the reduction of the size of the stud bolts, now shorter and external. Making full use of all the additional space ensured by the flanged design, the lights have been redesigned wider and able to link up perfectly with the ones of the Malossi engine cases.

The shape of the exhaust also features a structure fitted with an exceptionally thin crossbar with an elliptical-shaped dual port, to minimize stress for the piston ring, combined with an **exhaust connection, part of the structure and following its shape.**

The inner profile of the head, once again modular, has evolved completely and thanks to its design it now guarantees more torque at all engine speeds. **The head cover is made of forged aluminium, red anodized and lathed in high precision CNC machines.**

The installation of a Testa Rossa Flanged Mount cylinder necessarily requires installation on a C-One or RC-One Malossi case and the use of an engine shaft with the length of the connecting rod that differs from the original. To make full use of the potential of these cylinders, it is necessary to draw fully from the Malossi catalogue, selecting all the racing components produced by the Bolognese company.

Technical features

CYLINDER KIT	COOLING	TIMING SYSTEM	MATERIAL	BORE mm	STROKE mm	CAPACITY mm	ADVANCE	PISTON RING CLEARANCE mm	SQUISH	COMPRESSION RATIO	SPARK PLUG
3115883	H ₂ O	7 ports	Aluminium	52	44	93,4	16°	0,15	0,55	01:14.6	6314455.S0 IRIDIUM IW 34
3115901	H ₂ O	7 ports	Aluminium	47,6	39,3	69,93	16°	0,15	0,45	01:15.8	6314455.S0 IRIDIUM IW 34

New**MHR**
MALOSSI HYPER RACING

Gorilla Arm

Engine mount

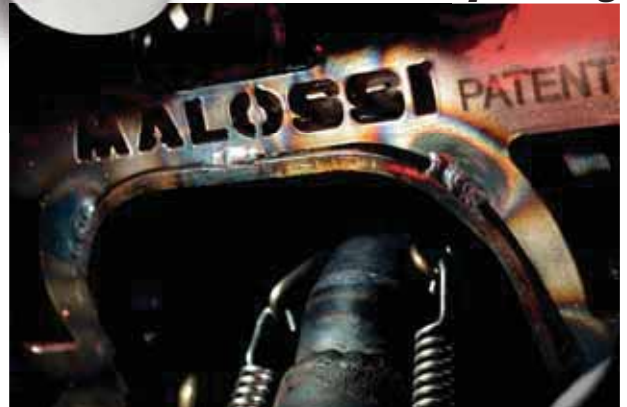
1816426**€ 209,00****PIAGGIO ZIP SP 50 2T LC***Only for vehicles
with a Malossi engine casing
MHR C-one / RC-one***Patent pending**

To revolutionize the world of racing scooters, it is necessary to go further, invent new opportunities for customization, and find innovative and original solutions.

Malossi actually did start from these requirements to conceive **GORILLA ARM**, the new and futuristic engine mount.

Apart from the fundamental requirements of performance and safety, the new Malossi engine mount stands out for three unique features that make it exceptionally versatile.

MORE RESISTANT

The characteristics of modern racing scooters reached absolutely unthinkable heights when they were introduced and it was clear for some time that the original engine mount was no longer suitable. The new Malossi **GORILLA ARM** reformulates the component and introduces an **extremely sturdy box structure that is absolutely insensitive to any type of torsion**. Its shape goes perfectly well with the increased length of the long arm Piaggio or C-One Malossi casing, more stable because less subject to sudden forces that govern the movement of a short arm casing. **Thanks to its completely redesigned anchor point**, that connects to the original attachments of the engine casing, **GORILLA ARM** is absolutely impossible to break.

MORE VERSATILE

Malossi has conceived **GORILLA ARM** to offer pilots a high number of opportunities for the **customization of the chassis**, by acting on the axle spacing and the work angle of the engine casing, the bearing element of the chassis.

Thanks to a system of eccentrics obtained from a block of selected aluminium and locked into the main structure of **GORILLA ARM**, it is possible to change the chassis of the scooter completely:

- 3 axle spacing adjustments
- 6 simple presets for the rotation of the eccentrics
- 2 front anchor points that vary the other adjustments by 30%.

All this guarantees an impressive number of positions on which you can adjust **GORILLA ARM**, literally sewing up the chassis of the scooter around you.

New



Gorilla Arm

MORE FREEDOM

The standard engine mount has always limited the development of racing exhaust systems in two-stroke scooters. To overcome this drawback, Malossi decided to revolutionize the coupling system that connects **GORILLA ARM** to the engine casing, **completely eliminating the central pin and greatly increasing the available space in order to finally be able to design exhaust systems with an optimal aerodynamic development.**

GORILLA ARM is a product that Malossi imagined and studied for a long time, trying endless technical solutions before depositing **the patent**. And now the idea, the passion, the work and the technology that allowed us to create **GORILLA ARM**, make us extremely proud to present to our enthusiastic customers the absolute state of the art in terms of strength, performance and customization.

TECHNICAL FEATURES

- Box-shaped system with four 4mm steel arms joined together by two 2 mm steel plates that incorporate a tube of \varnothing 45 mm with a thickness of 2.5 mm.
- All of this, laser cut, is joined with stretches of TIG welding in precise points, the result of structural calculations.
- It has reached the resistance to bending with elastic return at 15,000 newtons for 2,000 cycles.
- Stripped and painted with transparent paint treated in the kiln, equipped with every detail, including the instructions for assembly, for which there are no problems of any kind, being perfectly interchangeable with the original.
- Aluminium caps with double axle spacing holes and 5 threaded holes for engine tilt reference.
- High resistance plastic buffers.

Use	Racing
Level of compatible elaboration	Cárter C-one / RC-one





MALOSSI

Supplementary elements

C-ONE - Engine Crankcase

C-ONE
5715844
C-ONE
5715844
C-ONE
5716654
PIAGGIO
WHEEL 10
PIAGGIO
WHEEL 12/13
YAMAHA-
MINARELLI
WHEEL 12/13

	CYLINDER+HEAD Ø 47,6 TEAM Replica (pin)	3111584 € 324,71 (12)	3111584 € 324,71 (12)	3111584 € 324,71 (12)
	CRANKSHAFT RHQ PIN Ø 12 STROKE 39 mm CONNECTING ROD 80	53 7600 € 175,50	53 7600 € 175,50	53 7600 € 175,50
	CYLINDER+HEAD Ø 47,6 TEAM 2 CARRERA 39 mm	3115142 € 376,00	3115142 € 376,00	3115142 € 376,00
	FLANGED MOUNT CYLINDER Ø 47,6 STROKE 39 mm	3115901 € 402,00	3115901 € 402,00	3115901 € 402,00
	CRANKSHAFT RHQ PIN Ø 12 STROKE 39 mm CONNECTING ROD 85	53 9212 € 285,15	53 9212 € 285,15	53 9212 € 285,15
	CRANKSHAFT RHQ PIN Ø 12 - 13 STROKE 39 mm CONNECTING ROD 85	5316005 € 478,00	5316005 € 478,00	5316005 € 478,00
	SCOOTER RACING MHR Ø 47 - 47,6	32 9834 € 377,06	32 9027 € 314,23	32 9834 € 377,06
	SCOOTER RACING MHR TEAM Ø 47,6	3215341 € 366,18	3215341 € 366,18	3217327 € 366,18
	CARBURETTOR KIT PHBG Ø 19 TEAM	1611021.T € 202,60	1611021.T € 202,60	1611021.T € 202,60
	PHBG Ø 21 TEAM	1613890.TO € 210,60	1613890.TO € 210,60	1613890.TO € 216,92
	VHST Ø 28 TEAM	1616276 € 251,86	1616276 € 251,86	1616276 € 251,86
	INTAKE RUBBER Ø 28-30	1313799B € 41,82	1313799B € 41,82	1313799B € 41,82
	INNER ROTOR IGNITION	5514691 € 328,50	5514691 € 328,50	5514691 € 328,50
	INNER ROTOR IGNITION TEAM	5515001 € 350,00	5515001 € 350,00	5515001 € 350,00
	OVER RANGE	6114219 € 262,65	6114219 € 262,65	6114219 € 262,65
	MULTIVAR TEAM VARIATOR	5112645 € 77,25	5112645 € 77,25	5112645 € 77,25
	X K BELT BELT	6114118 € 38,25	6114118 € 38,25	6114118 € 38,25
	REAR PULLEY SYSTEM REAR PULLEY	6113101 € 174,40	6113101 € 174,40	6113101 € 174,40
	OVER RANGE ALUMINUM	6115781 € 365,00	6115781 € 365,00	6115781 € 365,00
	MULTIVAR ALUMINUM VARIATOR	5115644 € 87,55	5115644 € 87,55	5115644 € 87,55
	X K BELT TEAM ALUMINUM	6115668 € 44,88	6115668 € 44,88	6115668 € 44,88
	REAR PULLEY SYSTEM ALUMINUM REAR PULLEY	6114582 € 275,31	6114582 € 275,31	6114582 € 275,31
	VENTILVAR HALF-PULLEY	6113416B € 36,72	6113416B € 36,72	6115790 € 36,72
	TORSION CONTROLLER	2512828 € 4,45	2512828 € 4,45	2512828 € 4,45
	DELTA CLUTCH ADJUSTABLE CLUTCH	52 7880 € 77,89	52 7880 € 77,89	52 7880 € 77,89
	WING CLUTCH BELL CLUTCH BELL (FINNED RING)	7714147 € 90,00 Ø 107	7714147 € 90,00 Ø 107	7714147 € 91,80 Ø 107
	DELTA SYSTEM MHR CLUTCH BELL + ADJUSTABLE CLUTCH	5214738 € 156,00	5214738 € 156,00	5214738 € 156,00
	ROLLER CRANKCASE GEAR-BOX COVERS	2514521 € 95,00	2514521 € 95,00	2514521 € 95,00
	PINWHEEL SHAFT	6714530 € 66,30	6714530 € 66,30	-
	GEARS HTQ PRIMARY COUPLING Ø 17	6711449 € 60,41 z 16/37	67 9080 € 60,41 z 14/39	67 9080 € 60,41 z 14/39
	GEARS HTQ PRIMARY COUPLING Ø 17	6713339 € 61,71 z 15/38	6713339 € 61,71 z 15/38	6713339 € 61,71 z 15/38
	GEARS HTQ SECONDARY COUPLING PRESSED Ø 17	67 9968 € 61,65 z 14/47	67 9966 € 65,00 z 13/48	67 9966 € 65,00 z 13/48
	ENERGY PUMP WATER PUMP	5616363 € 123,00	5616363 € 123,00	5616363 € 123,00
	MUDGUARD	-	-	4517008 € 66,00
	GORILLA ARM	1816426 € 209,00	-	-
	AIR FORCE C/RC-One crankcase cover with kit starter	5717218 € 160,00	5717218 € 160,00	5717218 € 160,00

SUGGESTED STEP



MALOSSI

Supplementary elements

RC-ONE – Engine Crankcase

RC-ONE
5715845

RC-ONE
5715845

RC-ONE
5716668

PIAGGIO
WHEEL 10

PIAGGIO
WHEEL 12/13

YAMAHA-
MINARELLI
WHEEL 12/13

363

57 C-ONE - RC-ONE / PIAGGIO - YAMAHA

	FLANGED MOUNT CYLINDER Ø 52 STROKE 44 mm	3115883 € 437,00	3115883 € 437,00	3115883 € 437,00
	CRANKSHAFT RHQ PIN Ø 13 STROKE 44 mm CONNECTING ROD 90	5316029 € 465,00	5316029 € 465,00	5316029 € 465,00
	SCOOTER RACING MHR TEAM Ø 52	3216158 € 366,18	3216158 € 366,18	3217320 € 366,18
	CARBURETTOR KIT VHST Ø 28 TEAM	1616276 € 251,86	1616276 € 251,86	1616276 € 251,86
	INNER ROTOR IGNITION	5514691 € 328,50	5514691 € 328,50	5514691 € 328,50
	INNER ROTOR IGNITION TEAM	5515001 € 350,00	5515001 € 350,00	5515001 € 350,00
	OVER RANGE	6114219 € 262,65	6114219 € 262,65	6114219 € 262,65
	MULTIVAR TEAM VARIATOR	5112645 € 77,25	5112645 € 77,25	5112645 € 77,25
	X K BELT BELT	6114118 € 38,25	6114118 € 38,25	6114118 € 38,25
	REAR PULLEY SYSTEM REAR PULLEY	6113101 € 174,40	6113101 € 174,40	6113101 € 174,40
	OVER RANGE ALUMINUM	6115781 € 365,00	6115781 € 365,00	6115781 € 365,00
	MULTIVAR ALUMINUM VARIATOR	5115644 € 87,55	5115644 € 87,55	5115644 € 87,55
	X K BELT TEAM ALUMINUM	6115668 € 44,88	6115668 € 44,88	6115668 € 44,88
	REAR PULLEY SYSTEM ALUMINUM REAR PULLEY	6114582 € 275,31	6114582 € 275,31	6114582 € 275,31
	VENTILVAR HALF-PULLEY	6113416B € 36,72	6113416B € 36,72	6113416B € 36,72
	TORSION CONTROLLER	2512828 € 4,45	2512828 € 4,45	2512828 € 4,45
	DELTA CLUTCH EMBRAGUE REGULABLE	52 7880 € 77,89	52 7880 € 77,89	52 7880 € 77,89
	WING CLUTCH BELL CLUTCH BELL (FINNED RING)	7714147 € 90,00 Ø 107	7714147 € 90,00 Ø 107	7714147 € 90,00 Ø 107
	DELTA SYSTEM MHR CLUTCH BELL + ADJUSTABLE CLUTCH	5214738 € 156,00	5214738 € 156,00	5214738 € 156,00
	ROLLER CRANKCASE GEAR-BOX COVERS	2514521 € 95,00	2514521 € 95,00	2514521 € 95,00
	PINWHEEL SHAFT	6714530 € 66,30	6714530 € 66,30	-
	GEARS HTQ PRIMARY COUPLING Ø 17	6711449 € 60,41 z 16/37	67 9080 € 60,41 z 14/39	67 9080 € 60,41 z 14/39
	GEARS HTQ PRIMARY COUPLING Ø 17	6713339 € 61,71 z 15/38	6713339 € 61,71 z 15/38	6713339 € 61,71 z 15/38
	GEARS HTQ SECONDARY COUPLING PRESSED Ø 17	67 9968 € 61,65 z 14/47	67 9966 € 65,00 z 13/48	67 9966 € 65,00 z 13/48
	ENERGY PUMP WATER PUMP	5616363 € 123,00	5616363 € 123,00	5616363 € 123,00
	MUDGUARD	-	-	4517008 € 66,00
	GORILLA ARM	1816426 € 209,00	-	-
	AIR FORCE C/RC-One crankcase cover with kit starter	5717218 € 160,00	5717218 € 160,00	5717218 € 160,00

SUGGESTED STEP



MALOSSI

Moto 50

with ENGINE 

APRILIA

MX

RS

RS
euro 2
2006->RS4
euro 2

(MINARELLI AM 6)

(MINARELLI AM 3 > 6)

(DERBI D50B1)

(DERBI)

 CHECK "TYPE" SPECIFICATION (HOMOLOGATION MARK) ATTENTION: ASSEMBLY IS ONLY FOR vehicles WITHOUT IMMOBILIZER KEY

50 2T

LC

50 2T

LC

50 2T

LC

50 2T

LC

	CYLINDER+HEAD Ø 39,88 - Ø 40,3	3112199	3112199	3112977	3112977
	ALUMINIUM	€ 260,37 Ø 40,3	€ 260,37 Ø 40,3	€ 268,80 Ø 39,88	€ 268,80 Ø 39,88
	CYLINDER+HEAD Ø 50	3112228	3112228	3112985	3112985
	ALUMINIUM	€ 265,44	€ 265,44	€ 266,46	€ 266,46
	GP MHR REPLICA   PG. 432	-	3212665	-	3215230
	HOMOLOGATED EXHAUST SYSTEM		€ 211,09		€ 211,09
	SUPERMOTO MHR REPLICA  PG. 432	3212670	-	-	-
	HOMOLOGATED EXHAUST SYSTEM	€ 211,09			
	CYLINDER+HEAD Ø 39,88 - Ø 40,3	3112381	3112381	3112981	3112981
	MHR TEAM	€ 345,80 Ø 40,3	€ 345,80 Ø 40,3	€ 345,80 Ø 39,88	€ 345,80 Ø 39,88
	CYLINDER+HEAD Ø 50	3112609	3112609	3113221	3113221
MHR	€ 284,39	€ 284,39	€ 278,15	€ 278,15	
	CYLINDER+HEAD Ø 50	3112386	3112386	3112988	3112988
	MHR TEAM	€ 355,34	€ 355,34	€ 357,13	€ 357,13
	GP	-	3212222	3212613	-
	FOR MALOSSI CYLINDERS (INLET) MHR		€ 311,89 (Ø 28)	€ 327,60 (Ø 28)	
	SUPERMOTO	-	-	-	-
	FOR MALOSSI CYLINDERS (INLET) MHR				
	CRANKSHAFT RHQ	5312280	5312280	5312990	5312990
	PIN Ø 12	€ 293,80	€ 293,80	€ 293,80	€ 293,80
	RADIAL ROLLER BEARING PG. 473	6614423E	6614423E	PG.473	PG.473
	FOR CRANKSHAFT	€ 33,66	€ 33,66		
	TC UNIT K15+MAGNET / RPM CONTROL	5512791	5512791	5512791	-
	ELECTRONIC CONTROLLER 	€ 127,72	€ 127,72	€ 127,72	
	DIGITRONIC	-	-	-	-
	VARIABLE ADVANCE				
	INNER ROTOR IGNITION MHR TEAM	5515003	5515003	5515003	5515003
	 ELECTRIC SYSTEM IS CUT OUT	€ 350,00	€ 350,00	€ 350,00	€ 350,00
	INNER ROTOR IGNITION MHR	5514688	5514688	5514688	5514688
	 ELECTRIC SYSTEM IS CUT OUT	€ 318,50	€ 318,50	€ 318,50	€ 318,50
	CLUTCH DISK SET	5216541	5216541	5216539	5216539
		€ 36,00	€ 36,00	€ 36,00	€ 36,00
	SPRING SET	2912235	2912235	2912018	2912018
	FOR CLUTCH	€ 6,20	€ 6,20	€ 7,80	€ 7,80

APRILIA		BETA				DERBI	
RX - SX 2007->	TUONO	ENDURO RR	ENDURO RR RACING	SUPERMOTARD RR	SUPERMOTARD RR ALU	GPR NUDE <-2005	GPR NUDE 2006->
(DERBI D50B0)	(MINARELLI AM 6)	(MINARELLI AM 6)	(MINARELLI AM 6)	(MINARELLI AM 6)	(MINARELLI AM 6)	(EBS050)	(D50B0)
50 2T LC	50 2T LC	50 2T LC	50 2T LC	50 2T LC	50 2T LC	50 2T LC	50 2T LC
3112977 € 268,80 Ø 39,88	3112199 € 260,37 Ø 40,3	3112199 € 260,37 Ø 40,3	3112199 € 260,37 Ø 40,3	3112199 € 260,37 Ø 40,3	3112199 € 260,37 Ø 40,3	3112147 € 242,69 Ø 39,88	3112977 € 268,80 Ø 39,88
3112985 € 266,46	3112228 € 265,44	3112228 € 265,44	3112228 € 265,44	3112228 € 265,44	3112228 € 265,44	3111693 € 245,43	3112985 € 266,46
-	3212665 € 211,09	-	-	-	-	3212793 € 228,35	-
3213491 € 234,15	-	-	-	-	-	-	-
3112981 € 345,80 Ø 39,88	3112381 € 345,80 Ø 40,3	3112381 € 345,80 Ø 40,3	3112381 € 345,80 Ø 40,3	3112381 € 345,80 Ø 40,3	3112381 € 345,80 Ø 40,3	3112371 € 345,80 Ø 39,88	3112981 € 345,80 Ø 39,88
3113221 € 278,15	3112609 € 284,39	3112609 € 284,39	3112609 € 284,39	3112609 € 284,39	3112609 € 284,39	3111985 € 257,78	3113221 € 278,15
3112988 € 357,13	3112386 € 355,34	3112386 € 355,34	3112386 € 355,34	3112386 € 355,34	3112386 € 355,34	3112376 € 357,13	3112988 € 357,13
-	3212222 € 311,89 (Ø 28)	-	-	-	-	3212613 € 327,60 (Ø 28)	3212613 € 327,60 (Ø 28)
3211982 € 378,72	-	3212284 € 378,72	-	3212284 € 378,72	3212336 € 346,80	-	-
5312990 € 293,80	5312280 € 293,80	5312280 € 293,80	5312280 € 293,80	5312280 € 293,80	5312280 € 293,80	5312590 € 293,80	5312990 € 293,80
PG.473	6614423E € 33,66	6614423E € 33,66	6614423E € 33,66	6614423E € 33,66	6614423E € 33,66	PG.473	PG.473
-	5512791 € 127,72	5512791 € 127,72	-	5512791 € 127,72	5512791 € 127,72	5512791 € 127,72	5512791 € 127,72
-	-	-	-	-	-	-	-
5515003 € 350,00	5515003 € 350,00	5515003 € 350,00	5515003 € 350,00	5515003 € 350,00	5515003 € 350,00	5515003 € 350,00	5515003 € 350,00
5514688 € 318,50	5514688 € 318,50	5514688 € 318,50	5514688 € 318,50	5514688 € 318,50	5514688 € 318,50	5514688 € 318,50	5514688 € 318,50
5216539 € 36,00	5216541 € 36,00	5216541 € 36,00	5216541 € 36,00	5216541 € 36,00	5216541 € 36,00	-	5216539 € 36,00
2912018 € 7,80	2912235 € 6,20	2912235 € 6,20	2912235 € 6,20	2912235 € 6,20	2912235 € 6,20	2912018 € 7,80	2912018 € 7,80



MALOSSI

Moto 50

with ENGINE 

APRILIA

MX

RS

RS
euro 2
2006->RS4
euro 2

(MINARELLI AM 6)

(MINARELLI AM 3 > 6)

(DERBI D50B1)

(DERBI)

50 2T

LC

50 2T









LC

50 2T

LC

50 2T

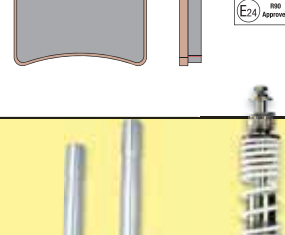
LC

	CARBURETTOR KIT	Ø 21	1611020	1612208 2000-> € 95,65 € 132,33	1612208 2000-> € 95,65 1611200 <-1996 € 118,04 € 155,00	1612615	1612615	€ 155,00
	CARBURETTOR KIT	Ø 21	-	-	1613524	1613524	1613524	€ 164,00
	CABLE STARTER							€ 164,00
	DIRECT STARTER	Ø 21	-	-	-	-	-	-
	INTAKE-MANIFOLD SET	Ø 21	2013800	2013800	2013800	2013800	2013800	€ 62,83
	FKM RUBBER			€ 62,83	€ 62,83	€ 62,83	€ 62,83	€ 62,83
	REED VALVE VL6		27 4235.C0	27 4235.C0	27 4235.C0	27 4235.C0	27 4235.C0	€ 32,36
	CARBON FIBRE			€ 32,36	€ 32,36	€ 32,36	€ 32,36	€ 32,36
	CARBON FIBRE PETALS		2712430.C0	2712430.C0	2712430.C0	2712431.C0	2712431.C0	€ 22,46
	FOR ORIGINAL REED VALVE			€ 22,46	€ 22,46	€ 22,46	€ 22,46	€ 22,46
	CARBURETTOR KIT	PHBH Ø 26	1612272	1612224	1611983	1611983	1611983	€ 208,24
	MHR			€ 184,21	€ 250,47	€ 250,47	€ 250,47	€ 208,24
	CARBURETTOR KIT	PHBH Ø 26	1613522	1613522	1613522	1613522	1613522	€ 272,47
	WITH REED VALVE			€ 272,47	€ 272,47	€ 272,47	€ 272,47	€ 272,47
	CARBURETTOR KIT	VHST 28	1613526	1613526	1613526	1613526	1613526	€ 303,38
	WITH REED VALVE	MHR TEAM		€ 303,38	€ 303,38	€ 303,38	€ 303,38	€ 303,38
	CONJUNTO COLECTOR ADMISION	Ø 28	2013801	2013801	2013801	2013801	2013801	€ 62,83
	FKM RUBBER			€ 62,83	€ 62,83	€ 62,83	€ 62,83	€ 62,83
	MHR							
	REED VALVE VL17		2714152.C0	2714152.C0	2714152.C0	2714152.C0	2714152.C0	€ 57,68
	CARBON FIBRE			€ 57,68	€ 57,68	€ 57,68	€ 57,68	€ 57,68
	REED VALVE VL18		2715810.C0	2715810.C0	2715810.C0	2715810.C0	2715810.C0	€ 58,00
	CARBON FIBRE			€ 58,00	€ 58,00	€ 58,00	€ 58,00	€ 58,00
	BRAKE PADS	FRONT	-	6215050	6216896	-	-	-
	ORGANIC BRAKE PADS			€ 6,24 1991->00	€ 9,50	-	-	-
	BRAKE PADS MHR	FRONT	-	62 9841	-	-	-	-
	ORGANIC BRAKE PADS			€ 6,10 1991->00	-	-	-	-
	BRAKE PADS MHR SYNT	FRONT	6215011	6215011	6215017	-	-	€ 16,00
	SINTERED BRAKE PADS			€ 16,00 2001->	€ 15,00	-	-	-
	BRAKE PADS	REAR	-	-	6215051	6215059	-	-
	ORGANIC BRAKE PADS				€ 5,72	€ 8,84	-	-
	BRAKE PADS MHR	REAR	-	-	6215076	6212164	-	-
	ORGANIC BRAKE PADS				€ 6,24	€ 8,50	-	-
	BRAKE PADS MHR SYNT	REAR	-	-	6215005	-	-	-
	SINTERED BRAKE PADS				€ 11,96	-	-	-
	RS24		-	-	-	-	-	-
	REAR SHOCK ABSORBER							
	RS24/10		-	-	4612949	-	-	-
	REAR SHOCK ABSORBER				€ 508,80	-	-	-
	FORK SHAFT PAIR F38R		-	-	4612994	-	-	-
	STEMS Ø 38				€ 933,81	-	-	-

APRILIA		BETA				DERBI	
RX - SX 2007->	TUONO	ENDURO RR	ENDURO RR RACING	SUPERMOTARD RR	SUPERMOTARD RR ALU	GPR NUDE <-2005	GPR NUDE 2006->
(DERBI D50B0)	(MINARELLI AM 6)	(MINARELLI AM 6)	(MINARELLI AM 6)	(MINARELLI AM 6)	(MINARELLI AM 6)	(EBS050)	(D50B0)
50 2T	LC	50 2T	LC	50 2T	LC	50 2T	LC
-	1612208 € 95,65	1612208 € 95,65	1612208 € 95,65	1612208 € 95,65	1612208 € 95,65	1612615 € 155,00	1612615 € 155,00
-	1613524 € 164,00	1613524 € 164,00	1613524 € 164,00	1613524 € 164,00	1613524 € 164,00	1613524 € 164,00	1613524 € 164,00
1613525 € 171,72	-	-	-	-	-	-	-
2013800 € 62,83	2013800 € 62,83	2013800 € 62,83	2013800 € 62,83	2013800 € 62,83	2013800 € 62,83	2013800 € 62,83	2013800 € 62,83
27 4235.C0 € 32,36	27 4235.C0 € 32,36	27 4235.C0 € 32,36	27 4235.C0 € 32,36	27 4235.C0 € 32,36	27 4235.C0 € 32,36	27 4235.C0 € 32,36	27 4235.C0 € 32,36
2712431.C0 € 22,46	2712430.C0 € 22,46	2712430.C0 € 22,46	2712430.C0 € 22,46	2712430.C0 € 22,46	2712430.C0 € 22,46	2712431.C0 € 22,46	2712431.C0 € 22,46
1611983 € 250,47	1612224 € 184,21	1612272 € 208,24	1612272 € 208,24	1612272 € 208,24	1612272 € 208,24	1611983 € 250,47	1611983 € 250,47
1613522 € 272,47	1613522 € 272,47	1613522 € 272,47	1613522 € 272,47	1613522 € 272,47	1613522 € 272,47	1613522 € 272,47	1613522 € 272,47
1613526 € 303,38	1613526 € 303,38	1613526 € 303,38	1613526 € 303,38	1613526 € 303,38	1613526 € 303,38	1613526 € 303,38	1613526 € 303,38
2013801 € 62,83	2013801 € 62,83	2013801 € 62,83	2013801 € 62,83	2013801 € 62,83	2013801 € 62,83	2013801 € 62,83	2013801 € 62,83
2714152.C0 € 57,68	2714152.C0 € 57,68	2714152.C0 € 57,68	2714152.C0 € 57,68	2714152.C0 € 57,68	2714152.C0 € 57,68	2714152.C0 € 57,68	2714152.C0 € 57,68
2715810.C0 € 58,00	2715810.C0 € 58,00	2715810.C0 € 58,00	2715810.C0 € 58,00	2715810.C0 € 58,00	2715810.C0 € 58,00	2715810.C0 € 58,00	2715810.C0 € 58,00
6215051 € 5,72	-	-	-	-	-	6216896 € 9,50	6216896 € 9,50
6215076 € 6,24	-	-	-	-	-	-	-
6215005 € 11,96	6215011 € 16,00	-	-	-	-	6215017 € 15,00	6215017 € 15,00
6215051 € 5,72	-	6215051 € 5,72	-	6215051 € 5,72	6215051 € 5,72	6215051 € 5,72	6215051 € 5,72
6215076 € 6,24	-	6215076 € 6,24	-	6215076 € 6,24	6215076 € 6,24	6215076 € 6,24	6215076 € 6,24
6215005 € 11,96	-	6215005 € 11,96	-	6215005 € 11,96	6215005 € 11,96	6215005 € 11,96	6215005 € 11,96
4612962 € 258,64	-	-	-	-	-	-	-
-	-	-	-	-	-	4612949 € 508,80	4612949 € 508,80
-	-	-	-	-	-	4612994 € 933,81	4612994 € 933,81



MALOSSI

Moto 50

with ENGINE **DERBI**GPR R
euro 2
2012->GPR RACING
<-2003GPR RACING
2004->2005GPR RACING
2006->

(EBE050 - EBS050)

(EBS050)

(D50B0)

 CHECK "TYPE" SPECIFICATION (HOMOLOGATION MARK) ATTENTION: ASSEMBLY IS ONLY FOR vehicles WITHOUT IMMOBILIZER KEY50 2T **LC** 50 2T **LC** 50 2T **LC** 50 2T **LC**

	CYLINDER+HEAD Ø 39,88 - Ø 40,3 ALUMINIUM	3112977 € 268,80 Ø 39,88	3112147 € 242,69 Ø 39,88	3112147 € 242,69 Ø 39,88	3112977 € 268,80 Ø 39,88
	CYLINDER+HEAD Ø 50 ALUMINIUM	3112985 € 266,46	3111693 € 245,43	3111693 € 245,43	3112985 € 266,46
	GP MHR REPLICA   HOMOLOGATED EXHAUST SYSTEM	3215230 € 211,09	3212667 € 189,50	3212793 € 228,35	-
	SUPERMOTO MHR REPLICA   HOMOLOGATED EXHAUST SYSTEM	-	-	-	-
	CYLINDER+HEAD Ø 39,88 - Ø 40,3 MHR TEAM	3112981 € 345,80 Ø 39,88	3112371 € 345,80 Ø 39,88	3112371 € 345,80 Ø 39,88	3112981 € 345,80 Ø 39,88
	CYLINDER+HEAD Ø 50 MHR	3113221 € 278,15	3111985 € 257,78	3111985 € 257,78	3113221 € 278,15
	CYLINDER+HEAD Ø 50 MHR TEAM	3112988 € 357,13	3112376 € 357,13	3112376 € 357,13	3112988 € 357,13
	GP FOR MALOSSI CYLINDERS (INLET) MHR	-	3212209 € 311,89 (Ø 28)	3212613 € 327,60 (Ø 28)	3212613 € 327,60 (Ø 28)
	SUPERMOTO FOR MALOSSI CYLINDERS (INLET) MHR	-	-	-	-
	CRANKSHAFT RHQ PIN Ø 12	5312990 € 293,80	*44*	5312590 € 293,80	5312990 € 293,80
	RADIAL ROLLER BEARING FOR CRANKSHAFT 	PG.473	PG.473	PG.473	PG.473
	TC UNIT K15+MAGNET / RPM CONTROL ELECTRONIC CONTROLLER 	5512791 € 127,72	-	5512791 € 127,72	5512791 € 127,72
	DIGITRONIC VARIABLE ADVANCE	-	-	-	-
	INNER ROTOR IGNITION MHR TEAM  ELECTRIC SYSTEM IS CUT OUT	5515003 € 350,00	5515003 € 350,00	5515003 € 350,00	5515003 € 350,00
	INNER ROTOR IGNITION MHR  ELECTRIC SYSTEM IS CUT OUT	5514688 € 318,50	5514688 € 318,50	5514688 € 318,50	5514688 € 318,50
	CLUTCH DISK SET	5216539 € 36,00	-	-	5216539 € 36,00
	SPRING SET FOR CLUTCH	2912018 € 7,80	2912018 € 7,80	2912018 € 7,80	2912018 € 7,80

44 - Para vehículos with ENGINE EBE050 : 5312320 - Para vehículos with ENGINE EBS050 : 5312590 € 293,80

DERBI							FANTIC
SENDA	Senda DRD PRO R	Senda DRD PRO SM	Senda DRD RACING R - SM	Senda EVO SM	Senda X-RACE R - X-RACE SM	Senda X-TREME R - X-TREME SM	CABALLERO
(EBE050 - EBS050)	(D50B0)	(D50B0)	(D50B0)	(D50B0)	(D50B0)	(D50B0)	(MINARELLI AM 6)
50 2T LC	50 2T LC	50 2T LC	50 2T LC	50 2T LC	50 2T LC	50 2T LC	50 2T LC
3112147 €242,69 Ø 39,88	3112977 €268,80 Ø 39,88	3112977 €268,80 Ø 39,88	3112977 €268,80 Ø 39,88	3112977 €268,80 Ø 39,88	3112977 €268,80 Ø 39,88	3112977 €268,80 Ø 39,88	3112199 €260,37 Ø 40,3
3111693 €245,43	3112985 €266,46	3112985 €266,46	3112985 €266,46	3112985 €266,46	3112985 €266,46	3112985 €266,46	3112228 €265,44
-	-	-	-	-	-	-	-
3212668 €211,09	3213488 €234,15	3213488 €234,15	3212668 €211,09	3212668 €211,09	3212668 €211,09	3212668 €211,09	-
3112371 €345,80 Ø 39,88	3112981 €345,80 Ø 39,88	3112981 €345,80 Ø 39,88	3112981 €345,80 Ø 39,88	3112981 €345,80 Ø 39,88	3112981 €345,80 Ø 39,88	3112981 €345,80 Ø 39,88	3112381 €345,80 Ø 40,3
3111985 €257,78	3113221 €278,15	3113221 €278,15	3113221 €278,15	3113221 €278,15	3113221 €278,15	3113221 €278,15	3112609 €284,39
3112376 €357,13	3112988 €357,13	3112988 €357,13	3112988 €357,13	3112988 €357,13	3112988 €357,13	3112988 €357,13	3112386 €355,34
-	-	-	-	-	-	-	-
3211982 €378,72 (Ø 28)	3213140 €378,72 (Ø 28)	3213140 €378,72 (Ø 28)	3211982 €378,72	3211982 €378,72	3211982 €378,72	3211982 €378,72	-
44	5312990 €293,80	5312990 €293,80	5312990 €293,80	5312990 €293,80	5312990 €293,80	5312990 €293,80	5312280 €293,80
PG.473	PG.473	PG.473	PG.473	PG.473	PG.473	PG.473	6614423E €33,66
-	-	-	-	-	-	-	5512791 €127,72
-	-	-	-	-	-	-	-
5515003 €350,00	5515003 €350,00	5515003 €350,00	5515003 €350,00	5515003 €350,00	5515003 €350,00	5515003 €350,00	5515003 €350,00
5514688 €318,50	5514688 €318,50	5514688 €318,50	5514688 €318,50	5514688 €318,50	5514688 €318,50	5514688 €318,50	5514688 €318,50
-	5216539 €36,00	5216539 €36,00	5216539 €36,00	5216539 €36,00	5216539 €36,00	5216539 €36,00	5216541 €36,00
2912018 €7,80	2912018 €7,80	2912018 €7,80	2912018 €7,80	2912018 €7,80	2912018 €7,80	2912018 €7,80	2912235 €6,20



MALOSSI

Moto 50

with ENGINE **DERBI**GPR R
euro 2
2012->GPR RACING
<-2003GPR RACING
2004->2005GPR RACING
2006->

(EBS050 - EBS050)

(EBS050)

(D50B0)

50 2T

LC

50 2T











LC

50 2T

LC

50 2T

LC

	CARBURETTOR KIT	Ø 21	1612615	1612615	1612615	1612615
			€ 155,00	€ 155,00	€ 155,00	€ 155,00
	CARBURETTOR KIT	Ø 21	1613524	1613524	1613524	1613524
	CABLE STARTER		€ 164,00	€ 164,00	€ 164,00	€ 164,00
		Ø 21	-	-	-	-
	DIRECT STARTER					
	INTAKE-MANIFOLD SET	Ø 21	2013800	2013800	2013800	2013800
	FKM RUBBER		€ 62,83	€ 62,83	€ 62,83	€ 62,83
	REED VALVE VL6		27 4235.C0	27 4235.C0	27 4235.C0	27 4235.C0
	CARBON FIBRE		€ 32,36	€ 32,36	€ 32,36	€ 32,36
	CARBON FIBRE PETALS		2712431.C0	2712431.C0	2712431.C0	2712431.C0
	FOR ORIGINAL REED VALVE		€ 22,46	€ 22,46	€ 22,46	€ 22,46
	CARBURETTOR KIT	PHBH Ø 26	1611983	1611983	1611983	1611983
		MHR	€ 250,47	€ 250,47	€ 250,47	€ 250,47
	CARBURETTOR KIT	PHBH Ø 26	1613522	1613522	1613522	1613522
	WITH REED VALVE	MHR	€ 272,47	€ 272,47	€ 272,47	€ 272,47
	CARBURETTOR KIT	VHST 28	1613526	1613526	1613526	1613526
	WITH REED VALVE	MHR TEAM	€ 303,38	€ 303,38	€ 303,38	€ 303,38
	CONJUNTO COLECTOR ADMISION	Ø 28	2013801	2013801	2013801	2013801
	FKM RUBBER	MHR	€ 62,83	€ 62,83	€ 62,83	€ 62,83
	REED VALVE VL17		2714152.C0	2714152.C0	2714152.C0	2714152.C0
	CARBON FIBRE	MHR	€ 57,68	€ 57,68	€ 57,68	€ 57,68
	REED VALVE VL18		2715810.C0	2715810.C0	2715810.C0	2715810.C0
	CARBON FIBRE	MHR TEAM	€ 58,00	€ 58,00	€ 58,00	€ 58,00
	BRAKE PADS	FRONT	-	-	6216896	6216896
	ORGANIC BRAKE PADS				€ 9,50	€ 9,50
	BRAKE PADS MHR	FRONT	-	-	-	-
	ORGANIC BRAKE PADS					
	BRAKE PADS MHR SYNT	FRONT	-	6215012	6215017	6215017
	SINTERED BRAKE PADS			€ 16,00	€ 15,00	€ 15,00
	BRAKE PADS	REAR	6215059	6215051	6215051	6215051
	ORGANIC BRAKE PADS		€ 8,84	€ 5,72	€ 5,72	€ 5,72
	BRAKE PADS MHR	REAR	6212164	6215076	6215076	6215076
	ORGANIC BRAKE PADS		€ 8,50	€ 6,24	€ 6,24	€ 6,24
	BRAKE PADS MHR SYNT	REAR	-	6215005	6215005	6215005
	SINTERED BRAKE PADS			€ 11,96	€ 11,96	€ 11,96
	RS24		-	-	-	-
	REAR SHOCK ABSORBER					
	RS24/10		-	-	4612949	4612949
	REAR SHOCK ABSORBER			€ 508,80	€ 508,80	
	FORK SHAFT PAIR F38R		-	-	4612994	4612994
	STEMS Ø 38			€ 933,81	€ 933,81	

DERBI

FANTIC

SENDA		Senda DRD PRO R		Senda DRD PRO SM		Senda DRD RACING R - SM		Senda EVO SM		Senda X-RACE R - X-RACE SM		Senda X-TREME R - X-TREME SM		CABALLERO	
(EBS050 - EBS050)		(D50B0)		(D50B0)		(D50B0)		(D50B0)		(D50B0)		(D50B0)		(MINARELLI AM 6)	
50 2T	LC	50 2T	LC	50 2T	LC	50 2T	LC	50 2T	LC	50 2T	LC	50 2T	LC	50 2T	LC
-		-		-		-		-		-		-		1612208	
														€ 95,65	
-		-		-		-		-		-		-		1613524	
														€ 164,00	
1613525		1613525		1613525		1613525		1613525		1613525		1613525		-	
€ 171,72		€ 171,72		€ 171,72		€ 171,72		€ 171,72		€ 171,72		€ 171,72			
2013800		2013800		2013800		2013800		2013800		2013800		2013800		2013800	
€ 62,83		€ 62,83		€ 62,83		€ 62,83		€ 62,83		€ 62,83		€ 62,83		€ 62,83	
27 4235.C0		27 4235.C0		27 4235.C0		27 4235.C0		27 4235.C0		27 4235.C0		27 4235.C0		27 4235.C0	
€ 32,36		€ 32,36		€ 32,36		€ 32,36		€ 32,36		€ 32,36		€ 32,36		€ 32,36	
2712431.C0		2712431.C0		2712431.C0		2712431.C0		2712431.C0		2712431.C0		2712431.C0		2712430.C0	
€ 22,46		€ 22,46		€ 22,46		€ 22,46		€ 22,46		€ 22,46		€ 22,46		€ 22,46	
1611983		-		-		1611983		1611983		1611983		1611983		1612272	
€ 250,47						€ 250,47		€ 250,47		€ 250,47		€ 250,47		€ 208,24	
1613522		1613522		1613522		1613522		1613522		1613522		1613522		1613522	
€ 272,47		€ 272,47		€ 272,47		€ 272,47		€ 272,47		€ 272,47		€ 272,47		€ 272,47	
1613526		1613526		1613526		1613526		1613526		1613526		1613526		1613526	
€ 303,38		€ 303,38		€ 303,38		€ 303,38		€ 303,38		€ 303,38		€ 303,38		€ 303,38	
2013801		2013801		2013801		2013801		2013801		2013801		2013801		2013801	
€ 62,83		€ 62,83		€ 62,83		€ 62,83		€ 62,83		€ 62,83		€ 62,83		€ 62,83	
2714152.C0		2714152.C0		2714152.C0		2714152.C0		2714152.C0		2714152.C0		2714152.C0		2714152.C0	
€ 57,68		€ 57,68		€ 57,68		€ 57,68		€ 57,68		€ 57,68		€ 57,68		€ 57,68	
2715810.C0		2715810.C0		2715810.C0		2715810.C0		2715810.C0		2715810.C0		2715810.C0		2715810.C0	
€ 58,00		€ 58,00		€ 58,00		€ 58,00		€ 58,00		€ 58,00		€ 58,00		€ 58,00	
6215051		-		-		-		6215051		6215051		6215051		-	
€ 5,72								€ 5,72		€ 5,72		€ 5,72			
6215076		-		-		-		6215076		6215076		6215076		-	
€ 6,24								€ 6,24		€ 6,24		€ 6,24			
6215005		-		-		-		6215005		6215005		6215005		-	
€ 11,96								€ 11,96		€ 11,96		€ 11,96			
6215051		-		-		-		6215051		6215051		6215051		-	
€ 5,72								€ 5,72		€ 5,72		€ 5,72			
6215076		-		-		-		6215076		6215076		6215076		-	
€ 6,24								€ 6,24		€ 6,24		€ 6,24			
6215005		-		-		-		6215005		6215005		6215005		-	
€ 11,96								€ 11,96		€ 11,96		€ 11,96			
4612962		-		-		-		4612962		4612962		4612962		-	
€ 258,64								€ 258,64		€ 258,64		€ 258,64			
-		-		-		-		-		-		-		-	
-		-		-		-		-		-		-		-	

MOTO 50

Moto 50

with ENGINE 

GILERA

HM

GSM H@K

RCR - SMT

CR E DERAPAGE

CRE SIX Comp.
ie 2013->

(DERBI EBE050)

(DERBI D50B0)

(MINARELLI AM 6)

(MINARELLI AM 6)

 CHECK "TYPE" SPECIFICATION (HOMOLOGATION MARK) ATTENTION: ASSEMBLY IS ONLY FOR vehicles WITHOUT IMMOBILIZER KEY

50 2T

LC

50 2T

LC

50 2T

LC

50 2T

LC

	CYLINDER+HEAD Ø 39,88 - Ø 40,3 ALUMINIUM	3112147 € 242,69 Ø 39,88	3112977 € 268,80 Ø 39,88	3112199 € 260,37 Ø 40,3	3112199 € 260,37 Ø 40,3
	CYLINDER+HEAD Ø 50 ALUMINIUM	3111693 € 245,43	3112985 € 266,46	3112228 € 265,44	3112228 € 265,44
	GP MHR REPLICA   HOMOLOGATED EXHAUST SYSTEM	-	-	-	-
	SUPERMOTO MHR REPLICA   HOMOLOGATED EXHAUST SYSTEM	- € 211,09	3212668 € 211,09	3212671 € 211,09	3212671 € 211,09
	CYLINDER+HEAD Ø 39,88 - Ø 40,3 MHR TEAM	3112371 € 345,80 Ø 39,88	3112981 € 345,80 Ø 39,88	3112381 € 345,80 Ø 40,3	3112381 € 345,80 Ø 40,3
	CYLINDER+HEAD Ø 50 MHR	3111985 € 257,78	3113221 € 278,15	3112609 € 284,39	3112609 € 284,39
	CYLINDER+HEAD Ø 50 MHR TEAM	3112376 € 357,13	3112988 € 357,13	3112386 € 355,34	3112386 € 355,34
	GP FOR MALOSSI CYLINDERS (INLET) MHR	-	-	-	-
	SUPERMOTO FOR MALOSSI CYLINDERS (INLET) MHR	-	3211982 € 378,72	-	-
	CRANKSHAFT RHQ PIN Ø 12	5312320 € 293,80	5312990 € 293,80	5312280 € 293,80	5312280 € 293,80
	RADIAL ROLLER BEARING FOR CRANKSHAFT 	 PG. 473	PG.473	PG.473	6614423E € 33,66
	TC UNIT K15+MAGNET / RPM CONTROL ELECTRONIC CONTROLLER 	-	-	5512791 € 127,72	5512791 € 127,72
	DIGITRONIC VARIABLE ADVANCE	-	-	-	-
	INNER ROTOR IGNITION MHR TEAM  ELECTRIC SYSTEM IS CUT OUT	5515003 € 350,00	5515003 € 350,00	5515003 € 350,00	5515003 € 350,00
	INNER ROTOR IGNITION MHR  ELECTRIC SYSTEM IS CUT OUT	5514688 € 318,50	5514688 € 318,50	5514688 € 318,50	5514688 € 318,50
	CLUTCH DISK SET	-	5216539 € 36,00	5216541 € 36,00	5216541 € 36,00
	SPRING SET FOR CLUTCH	2912018 € 7,80	2912018 € 7,80	2912235 € 6,20	2912235 € 6,20



MALOSSI

Moto 50

with ENGINE **GILERA****HM**

GSM H@K

RCR - SMT

CR E DERAPAGE

CRE SIX Comp. ie
2013->

(DERBI EBE050)

(DERBI D50B0)

(MINARELLI AM 6)

(MINARELLI AM 6)

50 2T

LC

50 2T







LC

50 2T

LC

50 2T

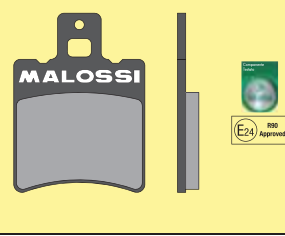
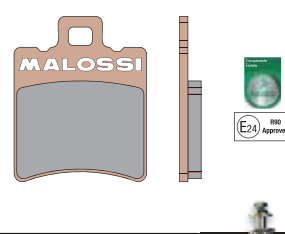
LC

	CARBURETTOR KIT	Ø 21	-	-	1612208 € 95,65	1612208 € 95,65
	CARBURETTOR KIT CABLE STARTER	Ø 21	-	-	1613524 € 164,00	1613524 € 164,00
	DIRECT STARTER	Ø 21	-	1613525 € 171,72	-	-
	INTAKE-MANIFOLD SET	Ø 21	2013800	2013800	2013800	2013800
	FKM RUBBER		€ 62,83	€ 62,83	€ 62,83	€ 62,83
	REED VALVE VL6		27 4235.C0	27 4235.C0	27 4235.C0	27 4235.C0
	CARBON FIBRE		€ 32,36	€ 32,36	€ 32,36	€ 32,36
	CARBON FIBRE PETALS		2712431.C0	2712431.C0	2712430.C0	2712430.C0
	FOR ORIGINAL REED VALVE		€ 22,46	€ 22,46	€ 22,46	€ 22,46
	CARBURETTOR KIT	PHBH Ø 26 MHR	1611983 € 250,47	1611983 € 250,47	1612272 € 208,24	1612272 € 208,24
	CARBURETTOR KIT WITH REED VALVE	PHBH Ø 26 MHR	1613522 € 272,47	1613522 € 272,47	1613522 € 272,47	1613522 € 272,47
	CARBURETTOR KIT WITH REED VALVE	VHST 28 MHR TEAM	1613526 € 303,38	1613526 € 303,38	1613526 € 303,38	1613526 € 303,38
	CONJUNTO COLECTOR ADMISION	Ø 28 MHR	2013801	2013801	2013801	2013801
	FKM RUBBER		€ 62,83	€ 62,83	€ 62,83	€ 62,83
	REED VALVE VL17		2714152.C0	2714152.C0	2714152.C0	2714152.C0
	CARBON FIBRE	MHR	€ 57,68	€ 57,68	€ 57,68	€ 57,68
	REED VALVE VL18		2715810.C0	2715810.C0	2715810.C0	2715810.C0
	CARBON FIBRE	MHR TEAM	€ 58,00	€ 58,00	€ 58,00	€ 58,00
	BRAKE PADS	FRONT	6215051	6215051	-	-
	ORGANIC BRAKE PADS		€ 5,72	€ 5,72		
	BRAKE PADS MHR	FRONT	6215076	6215076	-	-
	ORGANIC BRAKE PADS		€ 6,24	€ 6,24		
	BRAKE PADS MHR SYNT	FRONT	6215005	6215005	6215011	6215011
	SINTERED BRAKE PADS		€ 11,96	€ 11,96	€ 16,00	€ 16,00
	BRAKE PADS	REAR	6215051	6215051	-	-
	ORGANIC BRAKE PADS		€ 5,72	€ 5,72		
	BRAKE PADS MHR	REAR	6215076	6215076	-	-
	ORGANIC BRAKE PADS		€ 6,24	€ 6,24		
	BRAKE PADS MHR SYNT	REAR	6215005	6215005	-	-
	SINTERED BRAKE PADS		€ 11,96	€ 11,96		
	RS24		-	4612962	-	-
	REAR SHOCK ABSORBER			€ 258,64		
	RS24/10		-	-	-	-
	REAR SHOCK ABSORBER					
	FORK SHAFT PAIR F38R		-	-	-	-
	STEMS Ø 38					



MALOSSI

Moto 50

with ENGINE 

PEUGEOT	RIEJU	SHERCO	YAMAHA
XR7	RS2	HRD	DT 50 R euro 2
(MINARELLI AM 6)	(MINARELLI AM 6)	(MINARELLI AM 6)	(MINARELLI AM 6)

 CHECK "TYPE" SPECIFICATION (HOMOLOGATION MARK)  ATTENTION: ASSEMBLY IS ONLY FOR vehicles WITHOUT IMMOBILIZER KEY		50 2T	LC	50 2T	LC	50 2T	LC	50 2T	LC
	CYLINDER+HEAD Ø 39,88 - Ø 40,3	3112199		3112199		3112199		3112199	
	ALUMINIUM	€ 260,37	Ø 40,3	€ 260,37	Ø 40,3	€ 260,37	Ø 40,3	€ 260,37	Ø 40,3
	CYLINDER+HEAD Ø 50	3112228		3112228		3112228		3112228	
	ALUMINIUM	€ 265,44		€ 265,44		€ 265,44		€ 265,44	
	GP MHR REPLICA   PG. 432	-		3212666		-		-	
	HOMOLOGATED EXHAUST SYSTEM			€ 211,09					
	SUPERMOTO MHR REPLICA  PG. 432	-		-		-		-	
	HOMOLOGATED EXHAUST SYSTEM								
	CYLINDER+HEAD Ø 39,88 - Ø 40,3	3112381		3112381		3112381		3112381	
	MHR TEAM	€ 345,80	Ø 40,3	€ 345,80	Ø 40,3	€ 345,80	Ø 40,3	€ 345,80	Ø 40,3
	CYLINDER+HEAD Ø 50	3112609		3112609		3112609		3112609	
MHR	€ 284,39		€ 284,39		€ 284,39		€ 284,39		
	CYLINDER+HEAD Ø 50	3112386		3112386		3112386		3112386	
	MHR TEAM	€ 355,34		€ 355,34		€ 355,34		€ 355,34	
	GP	-		3212223		-		-	
	FOR MALOSSI CYLINDERS (INLET) MHR			€ 280,00					
	SUPERMOTO	-		-		3212340		-	
	FOR MALOSSI CYLINDERS (INLET) MHR					€ 340,00			
	CRANKSHAFT RHQ	5312280		5312280		5312280		5312280	
	PIN Ø 12	€ 293,80		€ 293,80		€ 293,80		€ 293,80	
	RADIAL ROLLER BEARING	6614423E		6614423E		6614423E		6614423E	
	FOR CRANKSHAFT 	€ 33,66		€ 33,66		€ 33,66		€ 33,66	
	TC UNIT K15+MAGNET / RPM CONTROL	-		5512791		5512791		5512791	
	ELECTRONIC CONTROLLER 			€ 127,72		€ 127,72		€ 127,72	
	DIGITRONIC	-		-		-		5513774	
	VARIABLE ADVANCE							€ 164,32	2007->
	INNER ROTOR IGNITION MHR TEAM	5515003		5515003		5515003		5515003	
	 ELECTRIC SYSTEM IS CUT OUT	€ 350,00		€ 350,00		€ 350,00		€ 350,00	
	INNER ROTOR IGNITION MHR	5514688		5514688		5514688		5514688	
	 ELECTRIC SYSTEM IS CUT OUT	€ 318,50		€ 318,50		€ 318,50		€ 318,50	
	CLUTCH DISK SET	5216541		5216541		5216541		5216541	
		€ 36,00		€ 36,00		€ 36,00		€ 36,00	
	SPRING SET	2912235		2912235		2912235		2912235	
	FOR CLUTCH	€ 6,20		€ 6,20		€ 6,20		€ 6,20	

YAMAHA							
DT 50 X euro 2	TZR						
(MINARELLI AM 6)	(MINARELLI AM 6)						

50 2T **LC** 50 2T **LC**

3112199 € 260,37 Ø 40,3	3112199 € 260,37 Ø 40,3	-	-	-	-	-	-
3112228 € 265,44	3112228 € 265,44	-	-	-	-	-	-
-	3213278 € 211,09	-	-	-	-	-	-
-	-	-	-	-	-	-	-
3112381 € 345,80 Ø 40,3	3112381 € 345,80 Ø 40,3	-	-	-	-	-	-
3112609 € 284,39	3112609 € 284,39	-	-	-	-	-	-
3112386 € 355,34	3112386 € 355,34	-	-	-	-	-	-
-	3212211 € 311,89	-	-	-	-	-	-
-	-	-	-	-	-	-	-
5312280 € 293,80	5312280 € 293,80	-	-	-	-	-	-
6614423E € 33,66	6614423E € 33,66	-	-	-	-	-	-
5512791 € 127,72	5512791 € 127,72	-	-	-	-	-	-
5513774 € 164,32 2007->	5513774 € 164,32 2007->	-	-	-	-	-	-
5515003 € 350,00	5515003 € 350,00	-	-	-	-	-	-
5514688 € 318,50	5514688 € 318,50	-	-	-	-	-	-
5216541 € 36,00	-	-	-	-	-	-	-
2912235 € 6,20	2912235 € 6,20	-	-	-	-	-	-



MALOSSI

Moto 50

with ENGINE 

PEUGEOT

RIEJU

SHERCO

YAMAHA

XR7

RS2

HRD

DT 50 R
euro 2

(MINARELLI AM 6)

(MINARELLI AM 6)

(MINARELLI AM 6)

(MINARELLI AM 6)

50 2T

LC

50 2T













LC

50 2T

LC

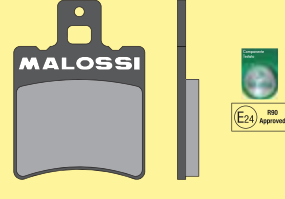
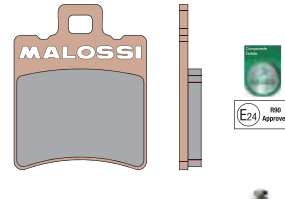
50 2T

LC

	CARBURETTOR KIT	Ø 21	1612208	1612208	1611020	1612208
			€ 95,65	€ 95,65	€ 132,33	€ 95,65
	CARBURETTOR KIT	Ø 21	1613524	1613524	-	1613524
	CABLE STARTER		€ 164,00	€ 164,00		€ 164,00
	DIRECT STARTER	Ø 21	-	-	-	-
	INTAKE-MANIFOLD SET	Ø 21	2013800	2013800	2013800	2013800
	FKM RUBBER		€ 62,83	€ 62,83	€ 62,83	€ 62,83
	REED VALVE VL6		27 4235.C0	27 4235.C0	27 4235.C0	27 4235.C0
	CARBON FIBRE		€ 32,36	€ 32,36	€ 32,36	€ 32,36
	CARBON FIBRE PETALS		2712430.C0	2712430.C0	2712430.C0	2712430.C0
	FOR ORIGINAL REED VALVE		€ 22,46	€ 22,46	€ 22,46	€ 22,46
	CARBURETTOR KIT	PHBH Ø 26	1612224	1612224	1612272	-
		MHR	€ 184,21	€ 184,21	€ 208,24	
	CARBURETTOR KIT	PHBH Ø 26	1613522	1613522	1613522	1613522
	WITH REED VALVE	MHR	€ 272,47	€ 272,47	€ 272,47	€ 272,47
	CARBURETTOR KIT	VHST 28	1613526	1613526	1613526	1613526
	WITH REED VALVE	MHR TEAM	€ 303,38	€ 303,38	€ 303,38	€ 303,38
	CONJUNTO COLECTOR ADMISION	Ø 28	2013801	2013801	2013801	2013801
	FKM RUBBER	MHR	€ 62,83	€ 62,83	€ 62,83	€ 62,83
	REED VALVE VL17		2714152.C0	2714152.C0	2714152.C0	2714152.C0
	CARBON FIBRE	MHR	€ 57,68	€ 57,68	€ 57,68	€ 57,68
	REED VALVE VL18		2715810.C0	2715810.C0	2715810.C0	2715810.C0
	CARBON FIBRE	MHR TEAM	€ 58,00	€ 58,00	€ 58,00	€ 58,00
	BRAKE PADS	FRONT	-	-	-	6215051
	ORGANIC BRAKE PADS					€ 5,72 2004->
	BRAKE PADS MHR	FRONT	-	-	-	6215076
	ORGANIC BRAKE PADS					€ 6,24 2004->
	BRAKE PADS MHR SYNT	FRONT	-	-	-	6215005
	SINTERED BRAKE PADS					€ 11,96 2004->
	BRAKE PADS	REAR	-	-	6215051	-
	ORGANIC BRAKE PADS				€ 5,72	
	BRAKE PADS MHR	REAR	-	-	6215076	-
	ORGANIC BRAKE PADS				€ 6,24	
	BRAKE PADS MHR SYNT	REAR	-	-	6215005	-
	SINTERED BRAKE PADS				€ 11,96	
	RS24		-	-	-	-
	REAR SHOCK ABSORBER					
	RS24/10		-	-	-	-
	REAR SHOCK ABSORBER					
	FORK SHAFT PAIR F38R		4612994	-	-	-
	STEMS Ø 38		€ 933,81			

YAMAHA							
DT 50 X euro 2	TZR						
(MINARELLI AM 6)	(MINARELLI AM 6)						

50 2T **LC** 50 2T **LC**

1612208 € 95,65	1612208 € 95,65	-	-	-	-	-	-
1613524 € 164,00	1613524 € 164,00	-	-	-	-	-	-
-	-	-	-	-	-	-	-
2013800 € 62,83	2013800 € 62,83	-	-	-	-	-	-
27 4235.C0 € 32,36	27 4235.C0 € 32,36	-	-	-	-	-	-
2712430.C0 € 22,46	2712430.C0 € 22,46	-	-	-	-	-	-
-	1612224 € 184,21	-	-	-	-	-	-
1613522 € 272,47	1613522 € 272,47	-	-	-	-	-	-
1613526 € 303,38	1613526 € 303,38	-	-	-	-	-	-
2013801 € 62,83	2013801 € 62,83	-	-	-	-	-	-
2714152.C0 € 57,68	2714152.C0 € 57,68	-	-	-	-	-	-
2715810.C0 € 58,00	2715810.C0 € 58,00	-	-	-	-	-	-
6215051 € 5,72 2004->	-	-	-	-	-	-	-
6215076 € 6,24 2004->	-	-	-	-	-	-	-
6215005 € 11,96 2004->	6215011 € 16,00 2004->	-	-	-	-	-	-
-	6215051 € 5,72 2004->	-	-	-	-	-	-
-	6215076 € 6,24 2004->	-	-	-	-	-	-
-	6215005 € 11,96 2004->	-	-	-	-	-	-
-	-	-	-	-	-	-	-
-	-	-	-	-	-	-	-
-	-	-	-	-	-	-	-





MALOSSI

Moto 125-135 4t

with ENGINE

APRILIA**BETA****DERBI**RS4
ie euro 3ENDURO RR
euro 3MOTARD RR
euro 3Senda DRD 4V
R - SM
ie euro 3

(WR 172)

(■) CHECK "TYPE" SPECIFICATION (HOMOLOGATION MARK)

		125 4T	LC	125 4T	LC	125 4T	LC	125 4T	LC
	CYLINDER ALUMINIUM Ø 63 - Ø 67	3115325 *45*		3114852		3114852		3115325 *45*	
		€ 576,80 Ø 67		€ 319,30 Ø 63		€ 319,30 Ø 63		€ 576,80 Ø 67	
	POWER CAM CAMSHAFT	-		*64*		*64*		-	
	GP MHR REPLICA 4 Stroke HOMOLOGATED EXHAUST SYSTEM	-		-		-		-	
	RED CHILLI OIL OIL FILTER	-		-		-		-	
	BRAKE PADS ORGANIC BRAKE PADS FRONT	-		-		-		-	
	BRAKE PADS MHR ORGANIC BRAKE PADS FRONT	-		-		-		-	
	BRAKE PADS MHR SYNT SINTERED BRAKE PADS FRONT	-		6215011 € 16,00		6215011 € 16,00		-	
	BRAKE PADS ORGANIC BRAKE PADS REAR	-		-		-		-	
	BRAKE PADS MHR ORGANIC BRAKE PADS REAR	-		-		-		-	
	REAR SHOCK ABSORBER RS 24/10	-		-		-		-	
	FORK SHAFT PAIR F38R STEMS Ø 38	-		-		-		-	



Products to be used exclusively for racing in places specially designed for such activity according to the regulations of the competent sporting authorities. We accept no liability resulting from improper use.

45 - I-TECH cylinder EQUIPPED WITH CDI

64 - TO COUPLE ONLY with MALOSSI CYLINDERS : 5913877 € 229,69

DERBI			FANTIC	HM	HONDA		
GPR 4 euro 3	MULHACÉN CAFE 4V euro 3	TERRA - TERRA Adventure 4V euro 3	CABALLERO euro 3	CR ME-F X (WR125-E012)	CBR R	CBR R ie	GROM (U.S.A.) ie
125 4T	LC	125 4T	LC	125 4T	LC	125 4T	LC
3115326 € 401,70 Ø 67	3115326 € 401,70 Ø 67	3115326 € 401,70 Ø 67	3114852 € 319,30 Ø 63	3114852 € 319,30 Ø 63	3112830 € 312,57 Ø 67	3116038 *45* € 525,00 Ø 67	-
-	-	-	*64*	*64*	-	-	-
-	-	-	-	-	3213306 € 360,36	-	3216365 € 493,00
-	-	-	-	-	-	-	-
-	-	-	-	-	-	-	-
-	-	-	-	6215011 € 16,00	-	-	-
-	-	-	-	6215065 € 10,40	-	-	-
-	-	-	-	62 9086 € 10,17	-	-	-
-	-	-	-	-	-	-	-
-	-	-	-	-	-	-	-

HONDA 125 2T LC

ALUMINIUM Ø 65 CYLINDER KITS

Malossi aluminium cylinder kit: the best balance between component performance and life of the component. The aluminium cylinder kit produced by Malossi s.p.A. is designed and manufactured with the specific objective of obtaining high combustion efficiency, long life, and a reliability that suits the Malossi name. Owing to the experience gained in the preparation of cylinder kits for race, Malossi engineers have developed the thermodynamics of aluminium cylinder kit to the fullest and designed the inner fluid mechanics of the cylinder kit with fanatical precision (see the transfer pipes, exhaust and combustion chamber), thereby obtaining a high level of turbulence in the combustion chamber. The latter has permitted a substantial reduction in specific consumption and a drastic reduction in the exhaust emission of pollutants.

31 6814 € 459,19

CRM - NSR - RAIDEN

Carburettor kit PHBH 30

1610982 € 193,81





MALOSSI

Moto 125-135 4t

with ENGINE

HONDA
HUSQVARNA
KTM

 MSX
ie

SONIC

 SMS 4
euro 3

 DUKE
ie

(WR 172)

() CHECK "TYPE" SPECIFICATION (HOMOLOGATION MARK)

		125 4T	125 4T	LC	125 4T	LC	125 4T	LC
	CYLINDER ALUMINIUM Ø 63 - Ø 67	-	3112830 € 312,57	Ø 67	3114852 € 319,30	Ø 63	-	-
	POWER CAM CAMSHAFT	-	-	-	*64*	-	-	-
	GP MHR REPLICA 4 Stroke HOMOLOGATED EXHAUST SYSTEM	3216365 € 493,00	-	-	-	-	3215202 € 465,50	-
	RED CHILLI OIL OIL FILTER	-	-	-	-	-	-	-
	BRAKE PADS ORGANIC BRAKE PADS FRONT	-	-	-	6215052 € 8,00	-	-	-
	BRAKE PADS MHR ORGANIC BRAKE PADS FRONT	-	-	-	6211525 € 8,20	-	-	-
	BRAKE PADS MHR SYNT SINTERED BRAKE PADS FRONT	-	-	-	6215020 € 16,00	-	-	-
	BRAKE PADS ORGANIC BRAKE PADS REAR	-	-	-	-	-	-	-
	BRAKE PADS MHR ORGANIC BRAKE PADS REAR	-	-	-	-	-	-	-
	REAR SHOCK ABSORBER RS 24/10	-	-	-	-	-	-	-
	FORK SHAFT PAIR F38R STEMS Ø 38	-	-	-	-	-	-	-



45 - I-TECH cylinder EQUIPPED WITH CDI

64 - TO COUPLE ONLY with MALOSS CYLINDERS : 5913877 € 229,69

MH		RIEJU		YAMAHA											
RX R euro 3		MARATHON PRO Off-Road/SM euro 3		135 ie 2011->		CRYPTON X 4V ie 2011->		EXCITER ie 2011->		JUPITER MX ie 2011->		MT-125 ie		SNIPER ie 2011->	
(WR*031)		(WR 082)		(T135)		(T135)		(T135)		(T135)		(E3J4E)		(T135)	
125 4T	LC	125 4T	LC	135 4T	LC	135 4T	LC	135 4T	LC	135 4T	LC	125 4T	LC	135 4T	LC
3114852		3114852		3114851 *45*		3114851 *45*		3114851 *45*		3114851 *45*		3116732		3114851 *45*	
€ 319,30	Ø 63	€ 319,30	Ø 63	€ 530,45	Ø 63	€ 530,45	Ø 63	€ 530,45	Ø 63	€ 530,45	Ø 63	€ 540,00	Ø 63	€ 530,45	Ø 63
64		*64*		*64*		*64*		*64*		*64*		*64*		*64*	
-		-		-		-		-		-		3213844		-	
-		-		-		-		-		-		€ 440,00		-	
-		-		-		-		-		-		0313826		-	
-		-		-		-		-		-		€ 6,00		-	
-		6216896		-		-		-		-		-		-	
-		€ 9,50		-		-		-		-		-		-	
-		6215017		-		-		-		-		-		-	
-		€ 15,00		-		-		-		-		-		-	
-		-		-		-		-		-		-		-	
-		-		-		-		-		-		-		-	
-		-		-		-		-		-		-		-	
-		-		-		-		-		-		4614245		-	
-		-		-		-		-		-		€ 417,18		-	
4612994		-		-		-		-		-		-		-	
€ 933,81		-		-		-		-		-		-		-	





MALOSSI

Moto 125-135 4t

with ENGINE 









YAMAHA

SPARK
ie 2011->WR R-X
ie euro 3YZF-R
ie euro 3
<-2013YZF-R
ie euro 3
2014->

(T135)

(E3D9E)

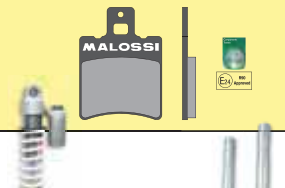
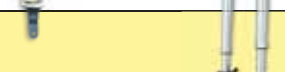
 CHECK "TYPE" SPECIFICATION (HOMOLOGATION MARK)

		135 4T	LC	125 4T	LC	125 4T	LC	125 4T	LC
	CYLINDER ALUMINIUM Ø 63 - Ø 67	3114851	*45*	3114349	*45*	3114349	*45*	3116732	
		€ 530,45	Ø 63	€ 530,45	Ø 63	€ 530,45	Ø 63	€ 540,00	Ø 63
	POWER CAM CAMSHAFT		*64*		*64*		*64*		*64*
	GP MHR REPLICA 4 Stroke HOMOLOGATED EXHAUST SYSTEM 					3213844		3216646	
						€ 440,00		€ 440,00	
	RED CHILLI OIL OIL FILTER			0313826		0313826		0313826	
				€ 6,00		€ 6,00		€ 6,00	
	BRAKE PADS ORGANIC BRAKE PADS FRONT								
	BRAKE PADS MHR ORGANIC BRAKE PADS FRONT								
	BRAKE PADS MHR SYNT SINTERED BRAKE PADS FRONT								
	BRAKE PADS ORGANIC BRAKE PADS REAR								
	BRAKE PADS MHR ORGANIC BRAKE PADS REAR								
	REAR SHOCK ABSORBER RS 24/10					4614245		4614245	
						€ 417,18		€ 417,18	
	FORK SHAFT PAIR F38R STEMS Ø 38								

Products to be used exclusively for racing in places specially designed for such activity according to the regulations of the competent sporting authorities. We accept no liability resulting from improper use.





1
2015

YAMAHA R-125 CUP
Lorenzo DE PERA

HALL OF
CHAMPIONS

R125
Cup

FOLLOW US ON OUR
SOCIAL CHANNELS

45 - I-TECH cylinder EQUIPPED WITH CDI

64 - TO COUPLE ONLY with MALOSSİ CYLINDERS : 5913877 € 229,69

**POWER CAM** camshaft

Aluminium COMPLETE CYLINDER Ø 63 pin Ø 14 H2O I-TECH 4-stroke

3114349 € 530,45

For vehicles produced <-2013

New 3116732 € 540,00

For vehicles produced 2014->

TECHNICAL FEATURES

Cilindro

Bore Ø 63 mm

Stroke 58,6 mm

Displacement 182,58 cc

Compression ratio 10,6:1



Material: primary aluminium alloy with a high content of hardened and tempered silicon, cylinder liner with silicon carbide coating in a galvanic nickel die and crossed smoothing with two diamond passages with very limited tolerances

Machining: on machine tools with high precision numerical control

Cylinder-piston connection with an allowance of 0.05 mm

Recalculated and upgraded heat exchange surfaces

Force Master 2 CDI with 4 different maps

Carburation adjusting

± 20% at min/medium/max

RPM limiter : + 1000 RPM

4 different maps



EXHAUST SYSTEM GP MHR REPLICA 4-Stroke homologated

3213844 € 440,00 - For vehicles produced <-2013

3216646 € 440,00 - For vehicles produced 2014->

New



RED FILTER E14 Ø 35,5

0411451 € 25,36

New

Cylinder kit Ø 52

Big Bore Testa rossa 90 cc

DRR Drx 90 2t

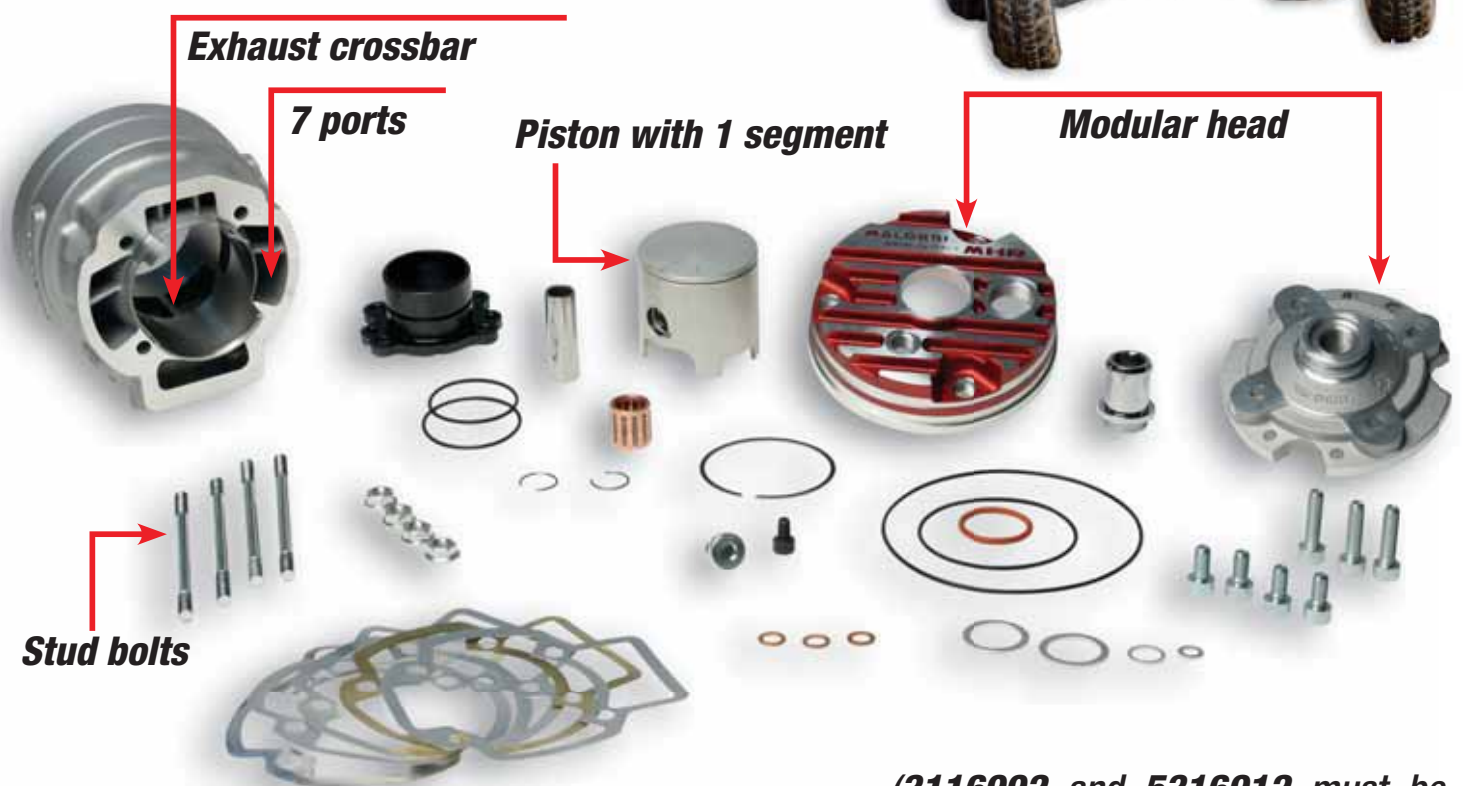
3116992 € 430,00

(3116992 and 5316912 must be mounted as a set)

CRANKSHAFT RHQ MHR TEAM

Pin Ø 13 Connection rod 90 (stroke 42,3 mm)

5316912 € 465,00





Use	Racing
Power range Ø 52	24-27 cv @13.000 rpm
Level of compatible elaboration	Shaft connecting rod 90 stroke 42,3



Carburettor
Ø 28 mm



System trasmission
OVER RANGE MHR
furia rossa



Pump casing
boring



HARD

BIG BORE Testa Rossa 90 cc

The new generation BIG BORE engine. Stud bolts, only for liquid-cooled scooters (7 ports and exhaust crossbar - piston with 1 segment - modular head - required boring of original case or C-One Malossi case - engine shaft with connecting rod different from the original).

Deriving directly from seven port technology, which animates the revolutionary Flanged Mount, BIG BORE Testa Rossa cylinders represent the latest success achieved thanks to the efforts and studies that Malossi has continued to devote to engines intended for original Piaggio and Yamaha cases and, with their unprecedented **capacity of 94 cc**, they allow the BIG BORE family to make a significant leap forward.

Externally almost indistinguishable from their flanged counterparts, BIG BORE Testa Rossa cylinders feature a **stud bolt framework compatible both with original engines and with the C-One Malossi case**. Even inside they are totally similar to Flanged Mounts, thanks to the renowned configuration with seven ports and dual exhaust port, with the only difference given by the limits set by the inner passage of the bolts that affects the size and development of the exhaust.

The head is once again modular, with new internal profiles specifically designed to increase the torque and feeling of the engine, now much brighter and even more progressive. **The head cover is made of forged aluminium, red anodized and lathed in high precision CNC machines.**

Technical features

CYLINDER KIT	COOLING	TIMING SYSTEM	MATERIAL	BORE mm	STROKE mm	CAPACITY mm	CAPACITY	PISTON RING CLEARANCE mm	SQUISH	COMPRESSION RATIO	SPARK PLUG
3116992	H ₂ O	7 ports	Aluminium	52	42,3	89,8	16°	0,15	0,55	01:14.6	6314455.S0 IRIDIUM IW 34



MALOSSI

ATV-QUAD

with ENGINE 

ACCESS

AEON MOTOR

SPORT

COBRA

COBRA

CROSSLAND

(AT70)

(V69C)

300 4T

LC

50 2T



400 4T

LC

300 4T

LC

	CYLINDER+HEAD CAST-IRON PIN \emptyset 10 \emptyset 40	-	31 8562 € 120,74	-	-
	CYLINDER+HEAD CAST-IRON (PIN) \emptyset 47	-	31 7083 ¹ € 114,25 \emptyset 47 (10)	-	-
	CYLINDER+HEAD ALUMINIUM (PIN) MHR Replica \emptyset 47 - 52	-	31 8437 ¹ € 207,00 \emptyset 47 (10)	-	-
	CRANKSHAFT RHQ PIN \emptyset 10	-	53 7891 € 175,50	-	-
	PIN \emptyset 12	-	53 8009 € 175,50	-	-
	MULTIVAR VARIATOR	5113892 € 139,05	51 7075 € 58,71	5116061 € 139,00	5113892 € 139,05
	X SPECIAL BELT BELT	-	6112741 € 15,25	-	-
	X K BELT BELT	-	6112742 € 26,33	-	-
	HTRoll FOR MULTIVAR	66 9917.Q0 € 19,12 gr.20	66 9823.M0 € 9,50 gr.07	66 9917.U0 € 19,12 gr.25	66 9917.Q0 € 19,12 gr.20
	HTRoll FOR ORIGINAL VARIATOR	-	66 9417.D0 € 7,24 gr.04,2	66 9917.S0 € 19,12 gr.22	66 9917.S0 € 19,12 gr.22
	VENTILVAR HALF-PULLEY ALSO FOR ORIGINAL VARIATOR	-	61 7152 € 21,71	-	-
	VARIABLE-SPEED DRIVE ADJUSTER SPRING	PG. 438 2914712.W0 € 14,19	PG.438	2911074.Y0 € 10,71	2914712.W0 € 14,19
	TORSION CONTROLLER ANTIFRICTION FIFTH WHEEL	-	2512827 € 4,45	-	-
	TORQUE DRIVER MOBILE DRIVEN SPLIT PULLEY	-	-	-	-
	FLY CLUTCH / MAXI FLY CLUTCH NOT ADJUSTABLE CLUTCH	-	52 8798 € 47,30	-	-
	DELTA CLUTCH / MAXI DELTA CLUTCH ADJUSTABLE CLUTCH	-	52 7879 € 77,89	-	-
	SPRING SET SPORT / MHR FOR DELTA CLUTCH / FLY CLUTCH	-	29 8746 € 14,50 29 8747 € 17,96	-	-
	SPRING SET RACING FOR ORIGINAL CLUTCH	-	29 7715 € 16,20	2915089 € 16,20	-
	CARBURETTOR KIT \emptyset 19	-	1611042 € 118,04	-	-
	\emptyset 21 - 25	-	1610998 € 116,64 \emptyset 21	-	-
	CARBURETTOR KIT VHST \emptyset 28 TEAM	-	1614022 € 251,86	-	-
	CONJUNTO COLECTOR \emptyset 24,5 VITON	-	2014524 € 52,02	-	-
	\emptyset 28	-	2014525 € 52,02	-	-
	\emptyset 30	-	2013847 € 52,02	-	-
	REED VALVE / VL14 MHR CARBON FIBRE	-	27 7731.C0 € 48,95 VL12	-	-
	CARBON FIBRE PETALS FOR ORIGINAL REED VALVE	-	27 7054.C0 € 18,71	-	-
	RED SPONGE FOR ORIGINAL AIR BOX	-	1411412 € 3,64	-	-
	DOUBLE RED SPONGE FOR ORIGINAL AIR BOX	-	1414498 € 5,73	-	-
	GEARS HTQ PRIMARY	-	-	-	-
	BRAKE PADS ORGANIC BRAKE PADS	REAR	6215059 € 8,84	6216060 € 10,92	-
	BRAKE PADS MHR ORGANIC BRAKE PADS	REAR	6212164 € 8,50	-	-
	BRAKE PADS MHR SYNT SINTERED BRAKE PADS	REAR	-	-	-
	BRAKE PADS ORGANIC BRAKE PADS	FRONT	-	6215059 € 8,84	-
	BRAKE PADS MHR ORGANIC BRAKE PADS	FRONT	-	6212164 € 8,50	-

19 - for the ASSEMBLY MODIFY the CRANKCASE



MALOSSI

ATV-QUAD

with ENGINE 

KYMCO

LAVERDA

MAXXER

MXer

MXer

QUASAR

(AR 03)

300 4T

LC

50 2T



150 4T



50 2T



	CYLINDER+HEAD CAST-IRON PIN \varnothing 10 \varnothing 40	-	-	-	-
	CYLINDER+HEAD CAST-IRON (PIN) \varnothing 47	-	31 8091 *47* € 128,21 \varnothing 47 (12)	-	31 7083 1 € 114,25 \varnothing 47 (10)
	CYLINDER+HEAD ALUMINIUM (PIN) MHR Replica \varnothing 47 - 52	-	-	-	31 8437 1 € 207,00 \varnothing 47 (10)
	CRANKSHAFT RHQ PIN \varnothing 10	-	-	-	53 7891 € 175,50
	CRANKSHAFT RHQ PIN \varnothing 12	-	-	-	53 8009 € 175,50
	MULTIVAR VARIATOR	5113892 € 139,05	51 7484 € 58,71	5112463 € 112,35	5112074 € 52,00
	X SPECIAL BELT BELT	-	-	-	6112741 € 15,25
	X K BELT BELT	6116568 € 43,86	-	-	6112742 € 26,33
	HTRoll FOR MULTIVAR	66 9917.Q0 € 19,12 gr.20	66 9823.M0 € 9,50 gr.07	6611095.P0 € 13,64 gr.13	66 9823.O0 € 9,50 gr.09
	HTRoll FOR ORIGINAL VARIATOR	66 9917.U0 € 19,12 gr.25	66 9823.M0 € 9,50 gr.07	-	66 9417.H0 € 7,24 gr.06,5
	VENTILVAR HALF-PULLEY ALSO FOR ORIGINAL VARIATOR	6111347B € 36,72	-	-	61 7152 € 21,71
	VARIABLE-SPEED DRIVE ADJUSTER SPRING	PG. 438 2914712.W0 € 14,19	PG.438	-	PG.438
	TORSION CONTROLLER ANTIFRICTION FIFTH WHEEL	-	2512828 € 4,45	-	-
	TORQUE DRIVER MOBILE DRIVEN SPLIT PULLEY	-	-	-	61 8312 € 85,57
	FLY CLUTCH / MAXI FLY CLUTCH NOT ADJUSTABLE CLUTCH	-	52 8797 € 47,30	-	52 8798 € 47,30
	DELTA CLUTCH / MAXI DELTA CLUTCH ADJUSTABLE CLUTCH	-	52 7880 € 77,89	-	52 7879 € 77,89
	SPRING SET SPORT / MHR FOR DELTA CLUTCH / FLY CLUTCH	-	29 8746 € 14,50 29 8747 € 17,96	-	29 8746 € 14,50 29 8747 € 17,96
	SPRING SET RACING FOR ORIGINAL CLUTCH	-	-	-	29 7715 € 16,20
	CARBURETTOR KIT \varnothing 19	-	1612288 € 113,96	-	-
	CARBURETTOR KIT \varnothing 21 - 25	-	-	-	1612073 € 119,93 \varnothing 21
	CARBURETTOR KIT VHST \varnothing 28 TEAM	-	-	-	1614022 € 251,86
	CONJUNTO COLECTOR VITON \varnothing 24,5	-	-	-	2014524 € 52,02
	CONJUNTO COLECTOR VITON \varnothing 28	-	-	-	2014525 € 52,02
	CONJUNTO COLECTOR VITON \varnothing 30	-	-	-	2013847 € 52,02
	REED VALVE / CARBON FIBRE VL14 MHR	-	-	-	27 7731.C0 € 48,95 VL12
	CARBON FIBRE PETALS FOR ORIGINAL REED VALVE	-	27 2728.C0 € 16,27	-	27 7054.C0 € 18,71
	RED SPONGE FOR ORIGINAL AIR BOX	-	-	-	1411412 € 3,64
	DOUBLE RED SPONGE FOR ORIGINAL AIR BOX	-	-	-	1414498 € 5,73
	GEARS HTQ PRIMARY	-	-	-	67 7014 € 68,44 z 15/41
	BRAKE PADS ORGANIC BRAKE PADS REAR	-	6215858 € 8,84 2003->	6215858 € 8,84 2003->	-
	BRAKE PADS MHR ORGANIC BRAKE PADS REAR	-	-	-	-
	BRAKE PADS MHR SYNT SINTERED BRAKE PADS REAR	-	-	-	-
	BRAKE PADS ORGANIC BRAKE PADS FRONT	-	-	-	-
	BRAKE PADS MHR ORGANIC BRAKE PADS FRONT	-	-	-	-

47 - CYLINDER ONLY (WITHOUT HEAD)

LAYERDA	PGO	SUZUKI	WT MOTORS				
QUASAR HP	BUG RACER	SPORT	KAYMAN WT				
(AT 50)	(PIAGGIO)		(1P57QMJ)				

180 4T 500 4T **LC** 80 2T 150 4T

-	-	-	-	-	-	-	-
-	-	-	-	-	-	-	-
-	-	-	-	-	-	-	-
-	-	-	-	-	-	-	-
-	-	-	-	-	-	-	-
5112396 € 110,68	5114260 € 173,04	5112122 € 52,00	5112133 € 110,68	-	-	-	-
-	-	-	-	-	-	-	-
-	6115125 € 88,54	-	-	-	-	-	-
6611095.M0 € 13,64 gr.11,5	6613554.B0 € 26,00 gr.15	66 9823.P0 € 9,50 gr.10	6611095.I0 € 13,64 gr.10,5	-	-	-	-
-	6613968.B0 € 17,81 gr.24	-	6614705.D0 € 16,50 gr.13	-	-	-	-
-	-	-	-	-	-	-	-
-	PG.438	PG.438	2911266.Y0 € 10,71	-	-	-	-
-	-	-	-	-	-	-	-
-	-	-	-	-	-	-	-
-	5212813 € 146,14	-	5212522 € 70,37 Ø 125	-	-	-	-
-	-	-	5212487 € 112,59 Ø 125	-	-	-	-
-	2913137 € 20,99	-	-	-	-	-	-
-	2912779 € 21,00	-	-	-	-	-	-
-	-	-	-	-	-	-	-
-	-	-	-	-	-	-	-
-	-	-	-	-	-	-	-
-	-	-	-	-	-	-	-
-	-	-	-	-	-	-	-
-	-	-	-	-	-	-	-
-	-	-	-	-	-	-	-
-	-	-	-	-	-	-	-
-	-	-	-	-	-	-	-
-	-	-	6215049 € 6,24	-	-	-	-
-	-	-	6215074 € 6,30	-	-	-	-
-	-	-	6215006 € 11,96	-	-	-	-
-	-	-	-	-	-	-	-
-	-	-	-	-	-	-	-





MALOSSİ

Moto 50 - 80cc Old production

with ENGINE 

APRILIA
HONDA

AF1

ET FIRE

TUAREG

MB 5
(marce)

50 2T

LC

50 2T

LC

50 2T

LC

50



	CYLINDER		-	-	-	-
	CAST-IRON					
	CYLINDER		-	-	-	31 4260
	ALUMINIUM					€ 203,00 Ø 44,5
	HEAD		-	-	-	-
	PINION		-	-	-	-
	MULTIVAR		-	-	-	51 7134
	VARIATOR					€ 58,71
	HTRoll		-	-	-	66 9823.HO
	FOR MULTIVAR					€ 9,50 gr.04,7
	CARBURETTOR KIT	SHA 15/15	1610935	1610935	1610935	-
	WITH MANIFOLD		€ 66,04	€ 66,04	€ 66,04	
	CARBURETTOR KIT	SHA 15/15	-	-	-	-
	CARBURETTOR KIT	PHBG 21	-	-	-	-
	WITH FILTER					
	CARBURETTOR KIT	PHBG	1610947	1610947	1610947	1610703
			€ 87,90 Ø 21	€ 87,90 Ø 21	€ 87,90 Ø 21	€ 109,73 Ø 21
	CARBURETTOR KIT	PHBH 26	-	-	-	-
	REED VALVE		-	-	-	-
	CARBON FIBRE					
	BRAKE PADS	FRONT	6215050	6215050	6215050	6215045
	ORGANIC BRAKE PADS		€ 6,24 1987->	€ 6,24 1987->	€ 6,24 1986->	€ 7,60 1982->
	BRAKE PADS MHR	FRONT	62 9841	62 9841	62 9841	-
	ORGANIC BRAKE PADS		€ 6,10 1987->	€ 6,10 1987->	€ 6,10 1986->	

HONDA

393

MBX		MBX R		MT 5 (marce)		MT		MTX 2		MTX 5 (marce)		MTX R		MTX	
50	LC	80	LC	50 2T	⚡	80 2T	⚡	50 2T	⚡	50 2T	⚡	50 2T	LC	80 2T	LC
31 4968		31 3738		-		-		-		-		31 4968		31 3738	
€ 176,57	Ø 45,5	€ 162,02	Ø 53									€ 176,57	Ø 45,5	€ 162,02	Ø 53
-		-		31 4260		-		31 6059		31 4260		-		-	
				€ 203,00	Ø 44,5			€ 164,87	Ø 45,5	€ 203,00	Ø 44,5				
-		-		-		-		-		-		-		-	
-		61 3417B		-		-		-		-		-		61 3417B	
		€ 11,72	z 18											€ 11,72	z 18
-		-		51 7134		-		-		51 7134		-		-	
				€ 58,71						€ 58,71					
-		-		66 9823.H0		-		-		66 9823.H0		-		-	
				€ 9,50	gr.04,7					€ 9,50	gr.04,7				
-		-		-		-		-		-		-		-	
-		-		-		-		-		-		-		-	
-		-		-		-		-		-		-		-	
-		1610666		1610703		1610420		1610981		1610703		1610918		1610666	
		€ 102,08	Ø 21	€ 109,73	Ø 21	€ 106,13	Ø 21	€ 109,98	Ø 21	€ 109,73	Ø 21	€ 108,07	Ø 21	€ 102,08	Ø 21
-		1610798		-		-		-		-		-		1610798	
		€ 247,86												€ 247,86	
-		-		-		-		-		-		-		27 3407.C0	
														€ 33,66	VL5
6215857		6215857		-		-		-		-		-		-	
€ 8,84	1983->	€ 8,84	1982->												
-		-		-		-		-		-		-		-	

MOTO 50 - 80cc Old production



MALOSSI

Moto 50 - 80cc old production

with ENGINE 

HONDA
MALAGUTI

NSR

 FIFTY
(3 marce)

FIFTY

 FIFTY TOP
(4 marce)

(FMORINI G30-303-304)

(FMORINI GSA)

(FMORINI GSA)

75

LC

50

LC

50

LC

50

LC

	CYLINDER CAST-IRON	31 3738 € 162,02 Ø 53	-	-	-
	CYLINDER ALUMINIUM	-	-	-	-
	HEAD	-	-	-	-
	PINION	61 3417B € 11,72 z 18	-	-	-
	MULTIVAR VARIATOR	-	-	-	-
	HTRoll FOR MULTIVAR	-	-	-	-
	CARBURETTOR KIT SHA 15/15 WITH MANIFOLD	-	-	1610808 € 58,63	1610808 € 58,63
	CARBURETTOR KIT SHA 15/15	-	-	1610942 € 54,75	1610942 € 54,75
	CARBURETTOR KIT PHBG 21 WITH FILTER	-	-	1610943 € 124,78	1610943 € 124,78
	CARBURETTOR KIT PHBG	1610666 € 102,08 Ø 21	1610976 € 124,84 Ø 21	1610810 € 126,96 Ø 19,5	1610810 € 126,96 Ø 19,5
	CARBURETTOR KIT PHBH 26	1610798 € 247,86	-	-	-
	REED VALVE CARBON FIBRE	-	-	-	-
	BRAKE PADS FRONT ORGANIC BRAKE PADS	6215857 € 8,84 1988->	-	-	6215046 € 6,35 1985->
	BRAKE PADS MHR FRONT ORGANIC BRAKE PADS	-	-	-	62 9087 € 6,24 1985->

MALAGUTI			SUZUKI		YAMAHA		
MDX	MISTRAL	TOP	TS ER 21	TS X	DT (marce)	DT	RD MX (marce)
(F.MORINI GSA)	(F.MORINI G30-303-304)	(F.MORINI G30-303-304)					
50	LC	50	LC	50	LC	50	LC
-	-	-	31 2452 € 135,49 Ø 50	-	-	31 4884 € 185,50 Ø 57,5	-
-	-	-	-	31 4894 € 192,00 Ø 47	31 3058 € 177,02 Ø 44,5	-	31 3058 € 177,02 Ø 44,5
-	-	-	-	-	38 3470 € 56,68 Ø 44,5	-	38 3470 € 56,68 Ø 44,5
-	-	-	-	61 1192 € 8,19 z 15	-	-	-
-	-	-	-	-	-	-	-
-	-	-	-	-	-	-	-
1610808 € 58,63	-	-	-	-	-	-	-
1610942 € 54,75	-	-	-	-	-	-	-
1610943 € 124,78	-	-	-	-	-	-	-
1610810 € 126,96 Ø 19,5	1610976 € 124,84 Ø 21	1610976 € 124,84 Ø 21	1610336 € 118,43 Ø 21	1610799 € 116,74 Ø 21	1610444 € 125,73 Ø 19,5	-	1610444 € 125,73 Ø 19,5
-	-	-	-	-	-	1610900 € 133,91	-
-	-	-	-	-	-	-	-
-	-	-	-	-	-	-	-
-	-	-	-	-	-	-	-



MALOSSI

Moto 50 - 80cc Old production

with ENGINE 

YAMAHA

TY
(marce)







50 2T









	CYLINDER CAST-IRON	-	-	-	-
	CYLINDER ALUMINIUM	31 3058 € 177,02 Ø 44,5	-	-	-
	HEAD	38 3470 € 56,68 Ø 44,5	-	-	-
	PINION	-	-	-	-
	MULTIVAR VARIATOR	-	-	-	-
	HTRoll FOR MULTIVAR	-	-	-	-
	CARBURETTOR KIT SHA 15/15 WITH MANIFOLD	-	-	-	-
	CARBURETTOR KIT SHA 15/15	-	-	-	-
	CARBURETTOR KIT PHBG 21 WITH FILTER	-	-	-	-
	CARBURETTOR KIT PHBG	1610444 € 125,73 Ø 19,5	-	-	-
	CARBURETTOR KIT PHBH 26	-	-	-	-
	REED VALVE CARBON FIBRE	-	-	-	-
	BRAKE PADS FRONT ORGANIC BRAKE PADS	-	-	-	-
	BRAKE PADS MHR FRONT ORGANIC BRAKE PADS	-	-	-	-

MALOSSI PIT BIKE

with ENGINE 

				HONDA	POLINI
				XRM	XP 4S
(LIFAN FY152FMH)	(LIFAN FY152FHI)	(LIFAN 1P55FMJ)	(LIFAN 1P56FMJ)	(XRM 110ME)	(156FMI)
110 4T 	125 4T 	140 4T 	150 4T 	100 4T 	125 4T 

	CYLINDER \varnothing 53	3113238	3113225	-	-	3113225	-
	ALUMINIUM pin \varnothing 13	€ 265,00	€ 265,00			€ 265,00	
	CYLINDER \varnothing 56	-	-	3113438	3113693	-	3113689
	ALUMINIUM (pin)			€ 280,00 (\varnothing 15)	€ 280,00 (\varnothing 15)		€ 280,00 (\varnothing 13)
	TC UNIT	-	-	-	-	55 8132	-
	ELECTRONIC CONTROLLER					€ 50,14	
	INNER ROTOR IGNITION	5513349	5513349	5513349	5513349	-	-
	 ELECTRIC SYSTEM IS CUT OUT	€ 376,00	€ 376,00	€ 376,00	€ 376,00		
	RACING SPRINGS SET	2913126	2913126	2913126	2913126	2913126	2913126
	FOR ORIGINAL CLUTCH	€ 8,00	€ 8,00	€ 8,00	€ 8,00	€ 8,00	€ 8,00



The control unit has an adjustable RPM limit function to prevent engine damage.

Rotating the trimmer with a screwdriver will adjust the rpm limit between a range of 11,600 to 13,000, or exclude the limit function altogether. Every click corresponds to 100 RPMs.

The control unit is shipped in position F.

Arrow position	0	E	F
RPM	11.600	13.000	Limiters switched off

Considering the difficulty in identifying the engine manufacturer in certain vehicles, we suggest to carefully verify stroke, pin diameter and mounting stud pattern (see diagram) before purchasing Malossi products.

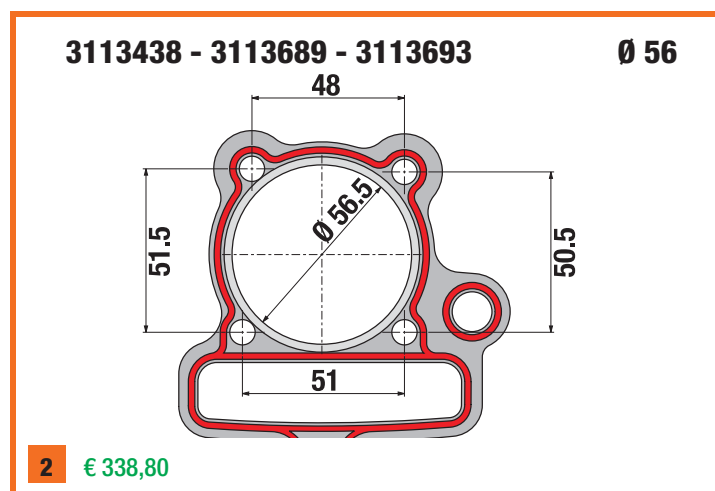
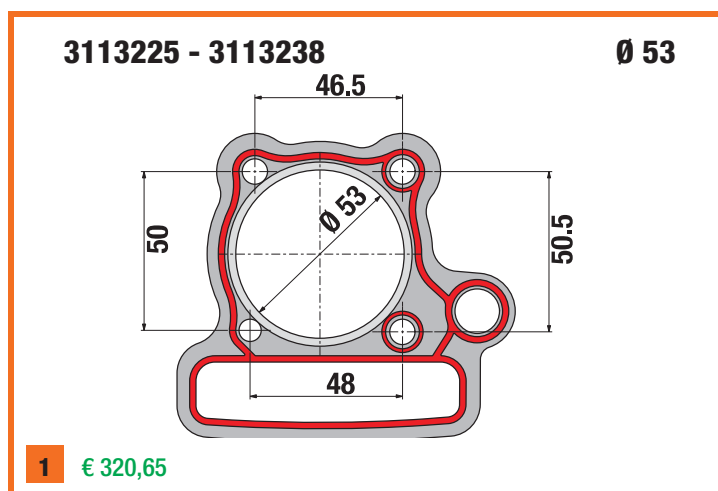

	Vehicle	Engine	Malossi Cylinder	Original vehicle's displacement	Stroke	\varnothing Pin
1	PIT BIKE	FY152FMH	3113238 \varnothing 53	107 / 110	49,5	13
2	POLINI XP 4S	156FMI	3113689 \varnothing 56	125	56	13
1	PIT BIKE / HONDA XRM	FY152FHI / XRM110ME	3113225 \varnothing 53	110 / 125	57	13
2	PIT BIKE	1P55FMJ	3113438 \varnothing 56	140	59	15
2	PIT BIKE	1P56FMJ	3113693 \varnothing 56	150	59	15



MALOSSI

Motorcycles MBK – PEUGEOT

with ENGINE

MBK

51 V

MAGNUM

PASSION

RACING

(AV 10)

(AV 10)

(AV 10)

(AV 10)

50



50



50



50



	CYLINDER+HEAD LC Ø 39 - 40	31 5477	31 5477	31 5477	31 5477
	ALUMINIUM	€ 204,49 Ø 39	€ 204,49 Ø 39	€ 204,49 Ø 39	€ 204,49 Ø 39
	CYLINDER LC Ø 39 - 40	31 6864	31 6864	31 6864	31 6864
	ALUMINIUM	€ 149,03 Ø 39	€ 149,03 Ø 39	€ 149,03 Ø 39	€ 149,03 Ø 39
	HEAD LC Ø 40	-	-	-	-
	WITH DECOMPRESSOR				
	HEAD LC Ø 40	-	-	-	-
	WITHOUT DECOMPRESSOR				
	CYLINDER+HEAD LC Ø 45,5	-	-	-	-
	WITH DECOMPRESSOR				
	CYLINDER+HEAD LC Ø 45,5	-	-	-	-
	WITHOUT DECOMPRESSOR				
	CYLINDER LC Ø 45,5	31 3013	31 3013	31 3013	31 3013
	ALUMINIUM	€ 206,00	€ 206,00	€ 206,00	€ 206,00
	HEAD LC Ø 45,5	-	-	-	-
	WITH DECOMPRESSOR				
	HEAD LC Ø 45,5	-	-	-	-
	WITHOUT DECOMPRESSOR				
	CYLINDER LC Ø 45,5	-	-	-	-
	CAST-IRON				
	CRANKSHAFT	53 5779	53 5779	53 5779	53 5779
	(PIN)	€ 202,00 Ø 13	€ 202,00 Ø 13	€ 202,00 Ø 13	€ 202,00 Ø 13
	MULTIVAR	-	-	-	-
	VARIATOR				
	X SPECIAL BELT	6112745	6112745	6112745	6112745
	BELT	€ 15,81	€ 15,81	€ 15,81	€ 15,81
	ROLLERS	-	-	-	-
	FOR MULTIVAR				
	VARIABLE-SPEED DRIVE ADJUSTER SPRING	-	-	-	-
	SPORT / MHR				
	VAR PLUS	51 6798	51 6798	51 6798	51 6798
	KIT	€ 33,12	€ 33,12	€ 33,12	€ 33,12
	VARIOTOP FOR VEHICLES WITH CLUTCH	-	-	-	-
	VARIOTOP FOR VEHICLES WITH CLUTCH	51 7723	51 7723	51 7723	51 7723
	(REVERSED FITTING)	€ 170,00	€ 170,00	€ 170,00	€ 170,00
	VARIOTOP FOR VEHICLES WITHOUT CLUTCH	51 6839	51 6839	51 6839	51 6839
		€ 160,00	€ 160,00	€ 160,00	€ 160,00
	VARIOTOP FOR VEHICLES WITHOUT CLUTCH	51 6921	51 6921	51 6921	51 6921
	FOR ORIGINAL VARIATOR COVER	€ 160,00	€ 160,00	€ 160,00	€ 160,00
	CRANKCASE SET	-	-	-	-
	CARBURETTORS SHA 15/15	72 5740	72 5740	72 5740	72 5740
		€ 43,01	€ 43,01	€ 43,01	€ 43,01
	PHBG 17,5	72 5741	72 5741	72 5741	72 5741
		€ 76,67	€ 76,67	€ 76,67	€ 76,67
	PHBG 19,5	72 5742	72 5742	72 5742	72 5742
		€ 86,24	€ 86,24	€ 86,24	€ 86,24
	CARBURETTOR KIT PHBG	-	-	-	-
	REED INTAKE-MANIFOLD SET Ø 15	-	-	-	-
	BIG CRANKCASE				
	REED INTAKE-MANIFOLD SET Ø 21	-	-	-	-
	BIG CRANKCASE				
	REED VALVE	27 3021.K0	27 3021.K0	27 3021.K0	27 3021.K0
	FOR ORIGINAL CRANKCASE	€ 20,25 VL2	€ 20,25 VL2	€ 20,25 VL2	€ 20,25 VL2
	GEARS HTQ	-	-	-	-
	PRIMARY				

PEUGEOT

103 RCX		103 SP [104 -105] - VOGUE		103 SPX		ADVENGER		FOX		HOLLYWOOD		XP		XP	
50		50 2T		50		50		50		50		50 2T		50 2T	
31 5098	€ 180,57 Ø 40	31 5098	€ 180,57 Ø 40	31 5098	€ 180,57 Ø 40	31 5098	€ 180,57 Ø 40	-	-	31 5098	€ 180,57 Ø 40	31 5098	€ 180,57 Ø 40	31 5098	€ 180,57 Ø 40
31 6746	€ 149,29 Ø 40	31 6746	€ 149,29 Ø 40	31 6746	€ 149,29 Ø 40	-	-	-	-	-	-	-	-	-	-
38 4692	€ 37,11	38 4692	€ 37,11	38 4692	€ 37,11	-	-	-	-	-	-	-	-	-	-
38 4734	€ 29,10	38 4734	€ 29,10	38 4734	€ 29,10	-	-	-	-	-	-	-	-	-	-
31 8394	€ 171,85	31 8394	€ 171,85	31 8394	€ 171,85	-	-	-	-	-	-	-	-	-	-
31 8393	€ 181,55	31 8393	€ 181,55	31 8393	€ 181,55	31 8393	€ 181,55	-	-	31 8393	€ 181,55	31 8393	€ 181,55	31 8393	€ 181,55
31 8388	€ 156,78	31 8388	€ 156,78	31 8388	€ 156,78	-	-	31 8388	€ 156,78	-	-	-	-	-	-
38 5337	€ 40,70	38 5337	€ 40,70	38 5337	€ 40,70	-	-	-	-	-	-	-	-	-	-
38 4735	€ 34,12	38 4735	€ 34,12	38 4735	€ 34,12	-	-	38 4735	€ 34,12	-	-	-	-	-	-
31 8384	€ 106,16	31 8384	€ 106,16	31 8384	€ 106,16	-	-	31 8384	€ 106,16	-	-	-	-	-	-
-	-	-	-	-	-	-	-	-	-	-	-	-	-	-	-
51 7123	€ 58,71	51 7160	€ 100,00	51 7123	€ 58,71	51 7160	€ 100,00	51 7073	€ 58,71	51 7160	€ 100,00	51 7160	€ 100,00	51 7160	€ 100,00
61 7220	€ 12,90	61 7219	€ 12,90	61 7220	€ 12,90	61 7219	€ 12,90	61 7214	€ 22,47	61 7219	€ 12,90	61 7219	€ 12,90	61 7219	€ 12,90
66 7147.40	€ 3,52 gr.02,8	66 7143.40	€ 5,75 gr.04	66 7147.40	€ 3,52 gr.02,8	66 7143.40	€ 5,75 gr.04	66 9823.M0	€ 9,50 gr.07	66 7143.40	€ 5,75 gr.04	66 7143.40	€ 5,75 gr.04	66 7143.40	€ 5,75 gr.04
-	-	-	-	-	-	-	-	29 7042.Y0 € 5,91	-	-	-	-	-	-	-
-	-	-	-	-	-	-	-	29 7043.R0 € 5,91	-	-	-	-	-	-	-
51 1887	€ 180,00	51 1885	€ 154,00	51 1887	€ 180,00	51 1885	€ 154,00	-	-	51 1885	€ 154,00	51 1885	€ 154,00	51 1885	€ 154,00
-	-	-	-	-	-	-	-	-	-	-	-	-	-	-	-
-	-	51 1886	€ 170,00	-	-	51 1886	€ 170,00	-	-	51 1886	€ 170,00	51 1886	€ 170,00	51 1886	€ 170,00
-	-	-	-	-	-	-	-	-	-	-	-	-	-	-	-
57 6548	€ 165,66	57 5208	€ 157,38	57 6548	€ 165,66	-	-	-	-	-	-	-	-	-	-
72 5740	€ 43,01	72 5740	€ 43,01	72 5740	€ 43,01	-	-	-	-	-	-	-	-	-	-
72 5741	€ 76,67	72 5741	€ 76,67	72 5741	€ 76,67	-	-	-	-	-	-	-	-	-	-
72 5742	€ 86,24	72 5742	€ 86,24	72 5742	€ 86,24	-	-	-	-	-	-	-	-	-	-
1610953	€ 126,29 Ø 15	1610930	€ 148,61 Ø 19	1610953	€ 126,29 Ø 15	-	-	1611018	€ 177,41 Ø 19	-	-	-	-	-	-
20 6856	€ 47,61	20 5037	€ 77,04	20 6856	€ 47,61	-	-	-	-	-	-	-	-	-	-
20 6436	€ 48,88	20 5039	€ 48,88	20 6436	€ 48,88	20 6138	€ 63,27	-	-	20 6138	€ 63,27	20 6138	€ 63,27	20 6138	€ 63,27
27 2356.C0	€ 18,83 VL1	27 2356.C0	€ 18,83 VL1	27 2356.C0	€ 18,83 VL1	-	-	-	-	-	-	-	-	-	-
-	-	-	-	-	-	-	-	67 6458	€ 65,00 z 16/32	-	-	-	-	-	-

*** Aluminium cylinder kit Ø 47
pin Ø 10 BIG D.E.P.S.**

31 7522 € 253,34

pin Ø 12 BIG D.E.P.S.

31 7524 € 253,34



*** Cast-iron cylinder kit Ø 46,5
pin Ø 10**

31 6156 € 101,76

pin Ø 12

31 6157 € 101,76



**EXHAUST SYSTEM TOO BAD
ONLY for BIG DEPS CYLINDERS
with OVERSIZED FIXING Ø 27**

3215442 € 124,00



**PRIMARY GEARS HTQ
(ONLY FOR vehicles WITH VARIATOR)**

67 7021 € 139,74



**CUTTER Ø 50
for motorcycles crankcases**

60 6361

€ 138,17



Cia

MULTIVAR PIAGGIO
motorcycles
51 3863 € 67,00

CLUTCH SPRINGS SET
(FOR vehicles WITH VARIATOR)
29 7307 € 15,70



X SPECIAL belt for variator
(13x6,5x978 mm 34°)
61 7227 € 11,70

**ORIGINAL VARIATOR
ADJUSTER SPRING**
RED - RACING
29 6955.R0 € 8,00
YELLOW - REINFORCED
29 7009.Y0 € 6,50



CRANKSHAFT HCP pin Ø 10
PIAGGIO motorcycles
53 7313 € 182,03



**2 ROLLER BEARINGS WITH
BALLS Ø 15x35x11 (STD)**
for crankshaft
66 4678E € 17,68



OIL-SEAL Ø 15x24x5 mm
FKM/PTFE crankshaft
flywheel side
6615296B
€ 8,90

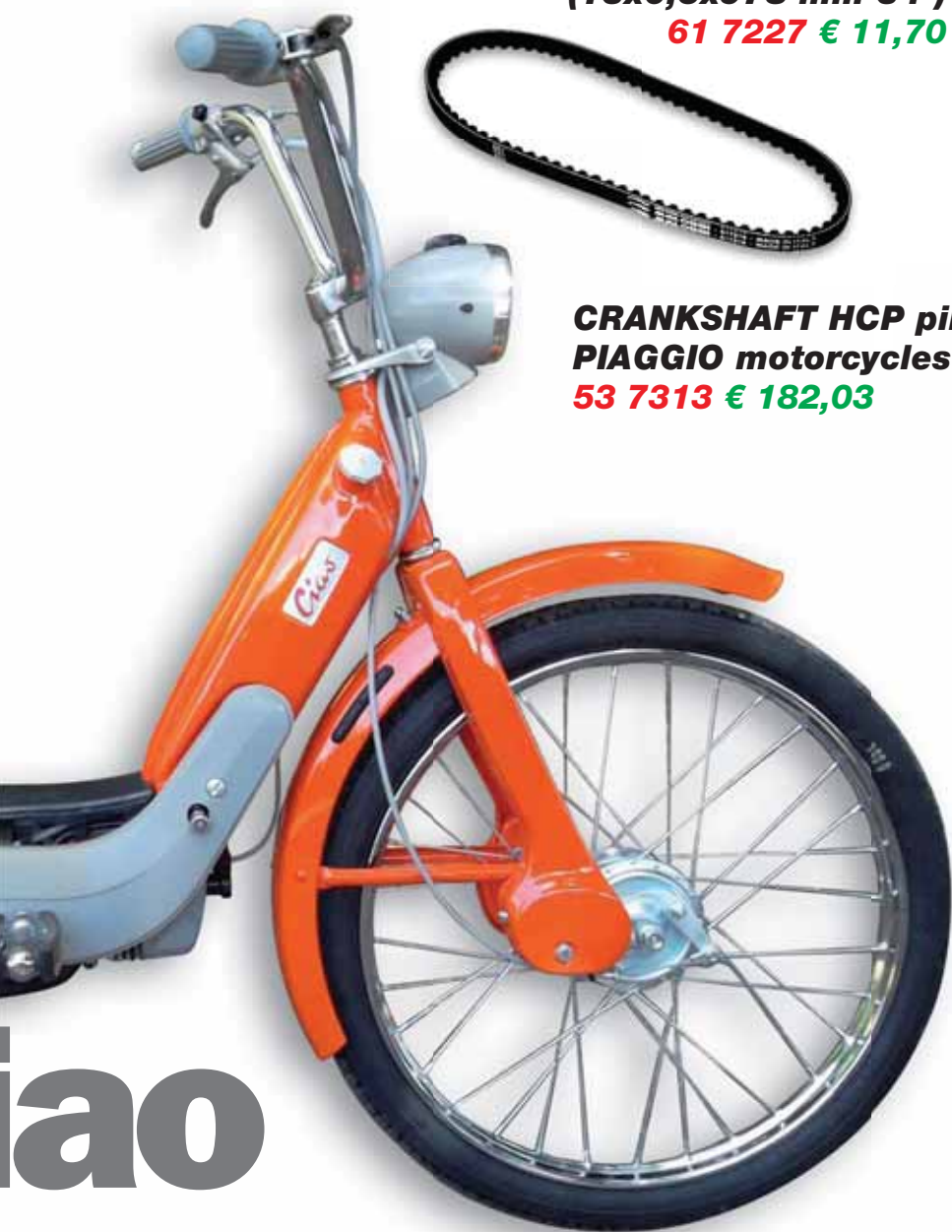

iao



*** Attention: bore the crankcase**

**Cast-iron cylinder kit Ø 43
pin Ø 10 BASE+CVF**

31 5116 € 120,00

pin Ø 12 BASE+CVF

31 5117 € 120,00



Carburettor kit

SHA 13 - 1610866

€ 46,34

PIAGGIO CRANKCASE

57 6809 € 156,93

**CLUTCH SPRINGS SET
(ONLY FOR vehicles
WITHOUT VARIATOR)**

29 7307 € 15,70

29 7306 € 14,00



**CLUTCH SHOES
AUTOMATIC MOTORCYCLES
without variator**

52 7005 € 24,99



DRIVEN PULLEY

€ 9,00

Ø 65 - 61 3548B

Ø 70 - 61 3538B

Ø 80 - 61 7280B



**X SPECIAL belt
for pulley Ø 70
(10x8x927 mm 36°)**

61 7224 € 10,96

**for pulley Ø 80
(10x8x940 mm 36°)**

61 7226 € 9,93

EXHAUST SYSTEM TOO BAD

3214894

€ 120,00



Products to be used exclusively for racing in places specially designed for such activity according to the regulations of the competent sporting authorities. We accept no liability resulting from improper use.



Cia

Three guys from Bologna covered 3500 km in 14 days riding their Piaggio Ciao mopeds until the Red Square in Moscow.

02/08/2014

www.malossi.com/ciao-mosca

CIAO

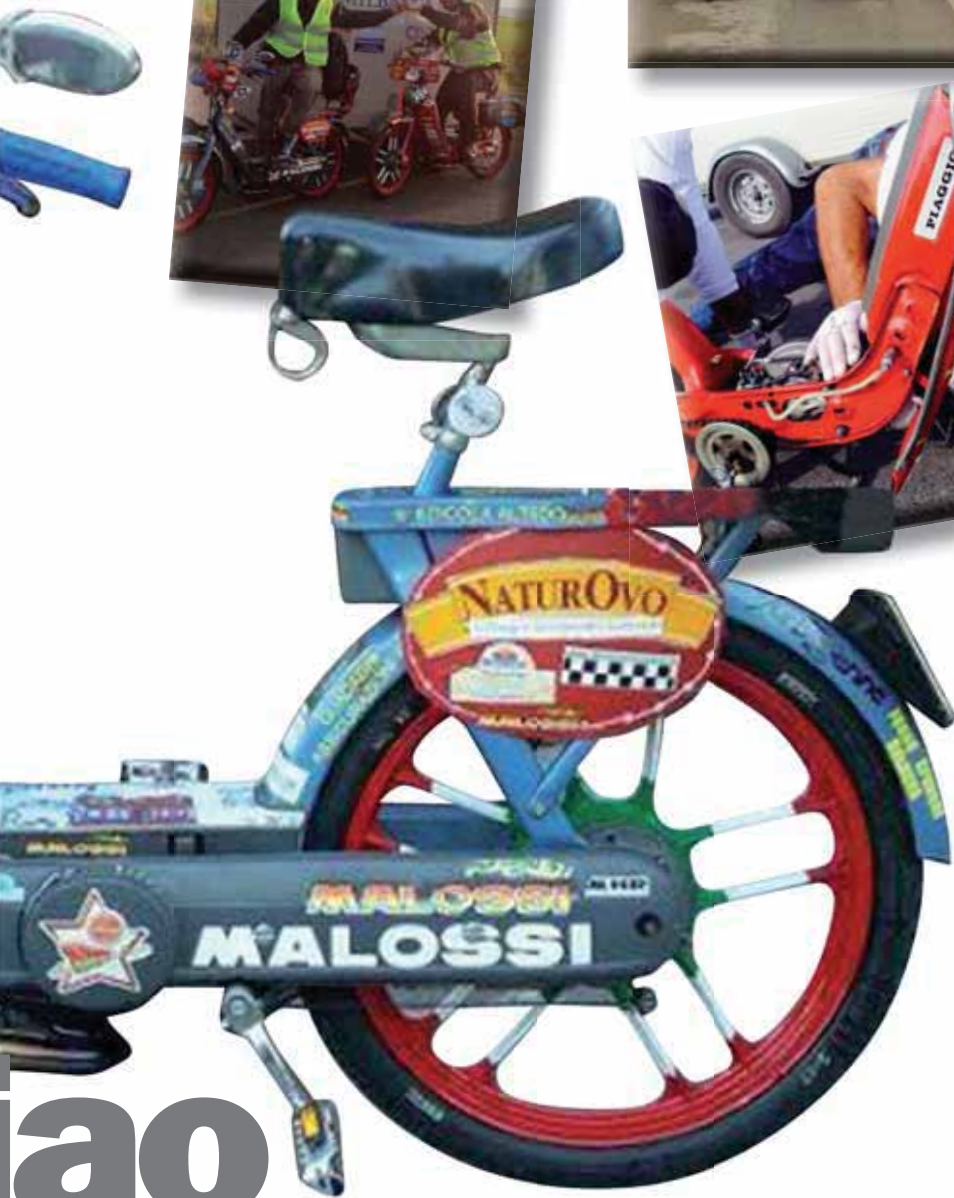

Ciao



MALOSSI

PIAGGIO Motorcycles

with ENGINE 

PIAGGIO

BOSS

BRAVO

CIAO

CIAO PX

50



50













50



50

**ATTENTION: BORE THE CRANKCASE**

	CYLINDER+HEAD Ø 43	31 5490	31 5490	31 5116	31 5116
	CAST-IRON PIN Ø 10	€ 100,17	€ 100,17	€ 120,00	€ 120,00
	CYLINDER+HEAD (●) Ø 46,5	31 6158	31 6158	31 6156	31 6156
	CAST-IRON PIN Ø 10	€ 101,76	€ 101,76	€ 101,76	€ 101,76
	CYLINDER+HEAD BIG D.E.P.S. (●) Ø 47	31 7523	31 7523	31 7522	31 7522
	ALUMINIUM PIN Ø 10	€ 253,34	€ 253,34	€ 253,34	€ 253,34
	CYLINDER+HEAD Ø 43	31 5491	31 5491	31 5117	31 5117
	CAST-IRON PIN Ø 12	€ 100,17	€ 100,17	€ 120,00	€ 120,00
	CYLINDER+HEAD (●) Ø 46,5	31 6159	31 6159	31 6157	31 6157
	CAST-IRON PIN Ø 12	€ 101,76	€ 101,76	€ 101,76	€ 101,76
	CYLINDER+HEAD BIG D.E.P.S. (●) Ø 47	31 7525	31 7525	31 7524	31 7524
	ALUMINIUM PIN Ø 12	€ 253,34	€ 253,34	€ 253,34	€ 253,34
	CRANKCASE	57 6810	57 6810	57 6810	57 6810
	ELECTRONIC COIL	€ 156,93	€ 156,93	€ 156,93	€ 156,93
	CRANKCASE	57 6809	57 6809	57 6809	57 6809
	MAGNETO POINTS COIL	€ 156,93	€ 156,93	€ 156,93	€ 156,93
	CRANKSHAFT PIN Ø 10	53 7313	53 7313	53 7313	53 7313
	FOR MALOSSI CRANKCASE	€ 182,03	€ 182,03	€ 182,03	€ 182,03
	CRANKSHAFT PIN Ø 12	53 1802	53 1802	53 1802	53 1802
	FOR MALOSSI CRANKCASE	€ 182,03	€ 182,03	€ 182,03	€ 182,03
	RADIAL BALL BEARINGS PG. 473	66 4678E	66 4678E	66 4678E	66 4678E
	FOR CRANKSHAFT	€ 17,68	€ 17,68	€ 17,68	€ 17,68
	MULTIVAR	51 3863	51 3863	51 3863	51 3863
	VARIATOR	€ 67,00	€ 67,00	€ 67,00	€ 67,00
	X SPECIAL BELT BELT	61 7314	61 7223	61 7227	61 7227
	ONLY FOR VEHICLES WITH VARIATOR	€ 16,83	€ 12,90	€ 11,70	€ 11,70
	HTRoll	66 9823.LO	66 9823.LO	66 9823.LO	66 9823.LO
	ROLLERS FOR MULTIVAR	€ 9,50 gr.06	€ 9,50 gr.06	€ 9,50 gr.06	€ 9,50 gr.06
	VARIATOR ADJUSTER SPRING PG. 438	29 7009.YO € 6,50	29 7009.YO € 6,50	29 7009.YO € 6,50	29 7009.YO € 6,50
	SPORT / MHR	29 6955.RO € 8,00	29 6955.RO € 8,00	29 6955.RO € 8,00	29 6955.RO € 8,00
	CLUTCH SHOE SET	52 7005	52 7005	52 7005	52 7005
	FOR VEHICLES WITHOUT VARIATOR	€ 24,99	€ 24,99	€ 24,99	€ 24,99
	SPRING SET FOR CLUTCH	29 7306	29 7306	29 7306	29 7306
	FOR VEHICLES WITHOUT VARIATOR	€ 14,00	€ 14,00	€ 14,00	€ 14,00
	SPRING SET FOR CLUTCH	29 7307	29 7307	29 7307	29 7307
	FOR VEHICLES WITH VARIATOR	€ 15,70	€ 15,70	€ 15,70	€ 15,70
	PULLEY Ø 80	-	-	61 7280B	61 7280B
				€ 9,00	€ 9,00
	X SPECIAL BELT BELT	-	-	61 7226	61 7226
	FOR PULLEY Ø 80			€ 9,93	€ 9,93
	PULLEY Ø 70	-	-	61 3538B	61 3538B
				€ 9,00	€ 9,00
	X SPECIAL BELT BELT	-	-	61 7224	61 7224
	FOR PULLEY Ø 70			€ 10,96	€ 10,96
	PULLEY Ø 65	-	-	61 3548B	61 3548B
				€ 9,00	€ 9,00
	CARBURETTOR KIT SHA 13	1610869	1610867	1610866	1610870
		€ 51,45	€ 47,45	€ 46,34	€ 45,36
	CARBURETTOR KIT PHBG 19	1610989	1610989	1610989	1610989
	FOR MALOSSI CRANKCASE	€ 189,00	€ 189,00	€ 189,00	€ 189,00
	TOO BAD	3214893	3214893	3214894	3214894
	EXHAUST SYSTEM	€ 120,00	€ 120,00	€ 120,00	€ 120,00
	TOO BAD EXHAUST SYSTEM ONLY FOR	3215438	3215438	3215442	3215442
	CYLINDER BIG D.E.P.S. (Clutch In Ø 27)	€ 124,00	€ 124,00	€ 124,00	€ 124,00
	PRIMARY GEARS HTQ	67 7021	67 7021	67 7021	67 7021
	FOR VEHICLES WITH VARIATOR	€ 139,74	€ 139,74	€ 139,74	€ 139,74

PIAGGIO		
GRILLO	SI	SUPERBRAVO
50	50	50
31 5490 € 100,17	31 5490 € 100,17	31 5490 € 100,17
31 6158 € 101,76	31 6158 € 101,76	31 6158 € 101,76
31 7523 € 253,34	31 7523 € 253,34	-
31 5491 € 100,17	31 5491 € 100,17	31 5491 € 100,17
31 6159 € 101,76	31 6159 € 101,76	31 6159 € 101,76
31 7525 € 253,34	31 7525 € 253,34	-
57 6810 € 156,93	57 6810 € 156,93	57 6810 € 156,93
57 6809 € 156,93	57 6809 € 156,93	57 6809 € 156,93
53 7313 € 182,03	53 7313 € 182,03	53 7313 € 182,03
53 1802 € 182,03	53 1802 € 182,03	53 1802 € 182,03
66 4678E € 17,68	66 4678E € 17,68	66 4678E € 17,68
51 3863 € 67,00	51 3863 € 67,00	51 3863 € 67,00
61 7222 € 12,60	61 7314 € 16,83	61 7223 € 12,90
66 9823.L0 € 9,50 gr.06	66 9823.L0 € 9,50 gr.06	66 9823.L0 € 9,50 gr.06
29 7009.Y0 € 6,50 29 6955.R0 € 8,00	29 7009.Y0 € 6,50 29 6955.R0 € 8,00	29 7009.Y0 € 6,50 29 6955.R0 € 8,00
52 7005 € 24,99	52 7005 € 24,99	52 7005 € 24,99
29 7306 € 14,00	29 7306 € 14,00	29 7306 € 14,00
29 7307 € 15,70	29 7307 € 15,70	29 7307 € 15,70
-	-	-
-	-	-
-	-	-
-	-	-
-	-	-
1610869 € 51,45	1610869 € 51,45	1610867 € 47,45
1610989 € 189,00	1610989 € 189,00	1610989 € 189,00
3214893 € 120,00	3214893 € 120,00	-
3215438 € 124,00	3215438 € 124,00	-
67 7021 € 139,74	67 7021 € 139,74	67 7021 € 139,74

New

Power Ignition



PIAGGIO BRAVO - BOSS 50
CIAO - CIAO PX 50
GRILLO - SI 50
SUPERBRAVO 50

5517192
€ 310.00



When preparing motors, ignition usually gets secondary attention. Yet this component is of vital importance since it is the one that manages the exact moment in which to ignite the spark on the glow plug and regulates the amount of current that determines the quality of the spark in order to obtain optimal combustion. Both in prepared and original engines, replacement with a newer and more performing ignition is an operation that can breathe new life into the engine itself and allows for more efficient and simple fine tuning.

Malossi and its team of engineers are proud to announce **Power**, the 12 Volt electronic ignition for the entire family of Piaggio motor bikes.

This ignition, which is the top in its category, is distinguished by its easy assembly, typical of a plug & play product. In fact, the kit includes everything that could be needed for proper assembly and immediate use.



In the **Power** package, you will find everything you need:

- Adapter ring to correctly attach the stator to the casing!
- 12 Volt (90 watt) 4 pole stator. It IS necessary to change all of the original bulbs!
- Light flywheel (885 g for a 16.2 kg/cm² moment of inertia) hot moulded and designed to resist the highest amount of rotations!
- Red plastic fan!
- Ready to use wiring with output cable for battery charging or stereo connection, for original modifications!
- Voltage regulator!

With this kit, your Ciao will be hungry for laps and opponents on the track.
Power ignites your passion!



MALOSSI

Automatic motorcycles

with ENGINE 

HONDA

CAMINO

MTX
(automatico)NSR
(automatico)

PX

50



50













50



50



	CYLINDER CAST-IRON	Ø 45,5	31 3642 € 149,46	-	-	31 3642 € 149,46
	CYLINDER ALUMINIUM	Ø 44,5 - 45,5	-	31 4260 € 203,00	31 4260 € 203,00	-
	HEAD	Ø 44,5 - 45,5	-	-	-	-
	CYLINDER ALUMINIUM	Ø 42	-	-	-	-
	MULTIVAR VARIATOR		-	51 7134 € 58,71	51 7134 € 58,71	-
	X SPECIAL BELT BELT		-	-	-	-
	HTRoll ROLLERS FOR MULTIVAR		-	66 9823.H0 € 9,50 gr.04,7	66 9823.H0 € 9,50 gr.04,7	-
	VARIATOR ADJUSTER SPRING SPORT / MHR		-	29 7042.YO € 5,91 29 7043.RO € 5,91	29 7042.YO € 5,91 29 7043.RO € 5,91	29 7042.YO € 5,91 29 7043.RO € 5,91
	TORSION CONTROLLER ANTIFRICTION FIFTH WHEEL		-	-	-	-
	CARBURETTOR KIT PHBG		1610944 € 142,02 Ø 21	1610898 € 98,44 Ø 21	1610898 € 98,44 Ø 21	1610693 € 176,44 Ø 18
		SHA 15/15	-	-	-	-
		SHA 16/16	-	-	-	-
	GEARS HTQ PRIMARY		67 6416 € 68,34 z 13/35	-	-	67 6419 € 74,88 z 13/35
	PINION		-	61 4695B € 5,12 z 17	61 4695B € 5,12 z 17	-
	BRAKE PADS ORGANIC BRAKE PADS	FRONT	-	-	6215857 € 8,84 1993->94	-



MALOSSI

VESPA [gears]

with ENGINE 

VESPA

ET3 Primavera

ETS

PK

PK HP

125 2T



125

















50

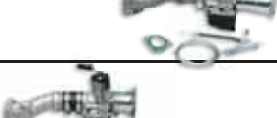

50



	CYLINDER+HEAD cast-iron Ø 47	-	-	31 7903 € 117,66	31 7903 € 117,66
	CYLINDER+HEAD cast-iron Ø 55	-	-	31 8691 € 117,56	31 8691 € 117,56
	CYLINDER+HEAD cast-iron Ø 57,5 to CRANKCASE - to CRANKCASE/CYLINDER	3116326 € 230,52	3116326 € 230,52	31 8694 € 132,54	31 8694 € 132,54
	CYLINDER+HEAD aluminium Ø 57,5 MHR	3115829 € 340,00	3115829 € 340,00	-	-
	CRANKSHAFT rod 97 stroke 51 (CONE Ø 20/19) rotating valve	5316594 € 380,00 5316595 € 380,00	5316594 € 380,00 5316595 € 380,00	-	-
	CRANKSHAFT stroke 60 CONE Ø 20 (ROD 97/105) reed valve	5316528 € 365,00 5316517 € 365,00 (*)	5316528 € 365,00 5316517 € 365,00 (*)	-	-
	RADIAL BALL BEARINGS for CRANKSHAFT PG. 473	PG.473	PG.473	PG.473	PG.473
	CARBURETTOR KIT (2nd serie) PHBL 25 REED to CYLINDER	1615907 € 253,67 1616561 MHR € 330,00	1615912 € 265,00	-	-
	INTAKE MANIFOLD KIT (2nd serie) REED to CYLINDER for PHBL 25	2015908 € 118,45 2016547 MHR € 185,00	2015911 € 118,45	-	-
	CARBURETTOR KIT VHST 28 MHR TEAM REED to CYLINDER	1616309 € 399,00	-	-	-
	INTAKE MANIFOLD KIT MHR REED to CYLINDER for VHST 28	2016319 € 185,00	-	-	-
	CARBURETTOR SHBC 19/19	-	-	A00866 € 76,67	-
	CARBURETTOR KIT SHB 16 RIGID to CRANKCASE	-	-	1610649 € 157,49	-
	CARBURETTOR KIT SHBC 19 RIGID to CRANKCASE	-	-	-	1610630 € 145,00
	CARBURETTOR KIT SHBC 20 RIGID to CRANKCASE	-	-	-	-
	INTAKE MANIFOLD KIT RIGID to CRANKCASE for SHBC 20	-	-	-	-
	CARBURETTOR KIT PHBL 24 RIGID to CRANKCASE	-	1610857 € 192,94	-	1610857 € 192,94
	INTAKE MANIFOLD KIT ELASTIC to CRANKCASE for PHBL 24	-	20 4709 € 60,00	-	20 4709 € 60,00
	CARBURETTOR KIT PHBL 25 ELASTIC to CRANKCASE	1610746 € 198,68	-	1610742 € 201,63	-
	INTAKE MANIFOLD KIT ELASTIC to CRANKCASE for PHBL 25	-	-	-	-
	CARBURETTOR KIT PHBL 25 REED to CRANKCASE	1610847 € 232,68	1610859 € 220,00	1610843 € 295,61	1610855 € 268,42
	INTAKE MANIFOLD KIT REED to CRANKCASE for PHBL 25	20 5459 € 109,00	20 5461 € 109,00	20 5460 € 109,00	20 5461 € 109,00
	EXHAUST SYSTEM POWER EXHAUST	3214430 € 98,00	-	-	-
	MULTIPLE SPEED GEAR (z10-14-17-20) SPORT	6716696 € 123,00	6716696 € 123,00	-	-
	(z10-15-18-20) MHR	6716207 € 123,00	6716207 € 123,00	-	-
	CLUTCH DISK SET SPORT (nr.)	5216520 € 21,00 (1)	5216520 € 21,00 (1)	5216520 *50* € 21,00 (1)	*50*
	CLUTCH DISK SET MHR (nr.)	5216521 € 26,00 (1)	5216521 € 26,00 (1)	5216521 *51* € 26,00 (1)	*51*
	CLUTCH DISK SET MHR TEAM (nr.)	5216522 € 37,00 (1)	5216522 € 37,00 (1)	5216522 *52* € 37,00 (1)	*52*
	CLUTCH SPRING (nr.)	29 3750 € 4,52 (1)	29 3750 € 4,52 (1)	29 3750 € 4,52 (1)	-
	VESPower IGNITION (CONE Ø 20/19) weight FLYWHEEL (kg)	5516955 1,2 € 317,60 *46* 5516958 0,9 € 310,00	-	-	-
	RS3 FRONT SHOCK ABSORBER	4614616 € 181,05	-	-	-
	RS24 REAR SHOCK ABSORBER	4614618 € 230,52	-	-	-

46 - THE VESPower cone Ø 19 flywheel Kg. 1,2 IS ALSO AVAILABLE: 5516951 € 317,60

50 - ONLY for PK FL / PK HP FL: (6), 5216523 € 22,50

51 - ONLY for PK FL / PK HP FL: (6), 5216524 € 29,00

52 - ONLY for PK FL / PK HP FL: (6), 5216525 € 59,00

⚠ - ATTENTION: in order to fit crankshafts art 5316528 or 5316517, kit art. 6617380 is also necessary (to be bought separately)

(*) - Art 5316517 TO COUPLE ONLY WITH cylinder Kit 3115829 or 3116326 (spacer kit art. 0717472 is also necessary, (to be bought separately))

VESPA

VESPA							
PK XL	PK	PK XL	SPECIAL				
50	125	125	50				
31 7903 € 117,66	-	-	31 7903 € 117,66	-	-	-	-
31 8691 € 117,56	-	-	31 8691 € 117,56	-	-	-	-
31 8694 € 132,54	3116326 € 230,52	3116326 € 230,52	31 8694 € 132,54	-	-	-	-
-	3115829 € 340,00	3115829 € 340,00	-	-	-	-	-
-	5316594 € 380,00 5316595 € 380,00	5316594 € 380,00 5316595 € 380,00	-	-	-	-	-
-	5316528 € 365,00 5316517 € 365,00 (*)	5316528 € 365,00 5316517 € 365,00 (*)	-	-	-	-	-
PG.473	PG.473	PG.473	PG.473	-	-	-	-
-	1615912 € 265,00	1615912 € 265,00	-	-	-	-	-
-	2015911 € 118,45	2015911 € 118,45	-	-	-	-	-
-	-	-	-	-	-	-	-
-	-	-	-	-	-	-	-
-	-	-	72 5193 € 89,94	-	-	-	-
1610803 € 144,29	-	-	1610650 € 162,02	-	-	-	-
1610630 € 145,00	-	-	-	-	-	-	-
-	-	-	1610645 € 131,72	-	-	-	-
-	-	-	-	-	-	-	-
1610857 € 192,94	1610849 € 178,13	1610857 € 192,94	-	-	-	-	-
20 4709 € 60,00	-	20 4709 € 60,00	-	-	-	-	-
-	1610748 € 214,14	-	1610738 € 219,41	-	-	-	-
-	-	-	-	-	-	-	-
1610855 € 268,42	1610851 € 207,59	1610859 € 220,00	1610839 € 279,21	-	-	-	-
20 5461 € 109,00	20 5460 € 109,00	20 5461 € 109,00	20 5459 € 109,00	-	-	-	-
-	-	-	3214425 € 98,00	-	-	-	-
-	6716696 € 123,00 6716207 € 123,00	6716696 € 123,00 6716207 € 123,00	6716696 € 123,00 6716207 € 123,00	-	-	-	-
5216520 € 21,00 (1)	5216520 *50* € 21,00 (1)	5216520 (1) € 21,00 (1)	5216520 (1) € 21,00 (1)	-	-	-	-
5216521 € 26,00 (1)	5216521 *51* € 26,00 (1)	5216521 (1) € 26,00 (1)	5216521 (1) € 26,00 (1)	-	-	-	-
5216522 € 37,00 (1)	5216522 *52* € 37,00 (1)	5216522 (1) € 37,00 (1)	5216522 (1) € 37,00 (1)	-	-	-	-
29 3750 € 4,52 (1)	29 3750 (1) € 4,52 (1)	29 3750 (1) € 4,52 (1)	29 3750 (1) € 4,52 (1)	-	-	-	-
-	-	-	5516952 € 317,60 1,2	-	-	-	-
-	-	-	4614616 € 181,05	-	-	-	-
-	-	-	4614618 € 230,52	-	-	-	-



MALOSS

VESPA [gears]

with ENGINE 

VESPA

COSA

COSA

COSA

PX

125 2T



150 2T













200 2T



80 2T

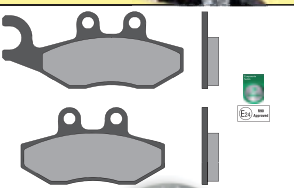

	CYLINDER+HEAD cast-iron Ø 61	3117181 € 215,25	3117181 € 215,25	-	3114940 € 185,00
	CYLINDER+HEAD aluminium Ø 65-68,5	-	-	3116346 € 383,00 Ø 68,5	-
	MHR	-	-	3116349 € 409,00 Ø 68,5	-
	MHR (stroke 60)	-	-	3116129 € 399,00 Ø 68,5	-
	CRANKSHAFT rod 110 (stroke 57) rotating valve	-	-	-	-
	CRANKSHAFT rod 110 (stroke 60) reed valve	-	-	-	-
	RADIAL BALL BEARINGS for crankshaft	PG. 473	PG.473	PG.473	PG.473
	COMPLETE ENGINE CRANKCASE ORIGINAL PIAGGIO	-	-	-	-
	CARBURETTOR SI 24/24 E	7216456 € 137,06	7216456 € 137,06	-	7216456 € 137,06
	CARBURETTOR KIT PHBH 30 DIRECT to CRANKCASE	-	-	-	1610600 € 228,86
	CARBURETTOR KIT PHBH 30 REED to CRANKCASE	-	-	-	1615895 € 298,00
	CONJUNTO COLECTOR REED to CRANKCASE for PHBH 30	-	-	-	2015896 € 160,68
	EXHAUST SYSTEM POWER EXHAUST BLACK sound	3217138 € 170,00	3217138 € 170,00	-	-
	CLUTCH DISK SET SPORT (springs number)	5216511 *48* € 22,00 (7)	5216511 *48* € 22,00 (7)	5216511 *48* € 22,00 (7)	5216505 € 20,00 (6)
	CLUTCH DISK SET MHR (springs number)	5216514 *49* € 26,00 (7)	5216514 *49* € 26,00 (7)	5216514 *49* € 26,00 (7)	5216510 € 24,50 (6)
	CLUTCH SPRING (springs number)	29 4029 € 5,00 (6)	29 4029 € 5,00 (6)	29 4586 € 5,70 (7)	29 4029 € 5,00 (6)
	GEARS HTQ z 23/64 PRIMARY	67 3730 *57* € 135,00	67 3730 *57* € 135,00	67 3888 *57* € 135,00	67 3730 € 135,00
	GEARS HTQ z 24/63 PRIMARY	67 5235 *58* € 135,00	67 5235 *58* € 135,00	67 5235 *58* € 135,00	-
	VESPower IGNITION Ø 20 weight FLYWHEEL (Kg)	5516953 (1,2) € 310,00 5516956 (0,9) € 310,00	5516953 (1,2) € 310,00 5516956 (0,9) € 310,00	5516953 (1,2) € 310,00 5516956 (0,9) € 310,00	-
	VESPower IGNITION Ø 20 weight FLYWHEEL (Kg) ONLY for vehicles WITH ELECTRIC STARTER	-	-	-	-
	SCREEN CLEAR	-	-	-	4515122 € 59,00
	SCREEN LIGHT SMOKE	-	-	-	4515120 € 64,00
	BRAKE PADS ORGANIC BRAKE PADS FRONT	-	-	-	-
	BRAKE PADS MHR ORGANIC BRAKE PADS FRONT	-	-	-	-
	BRAKE PADS MHR SYNT SINTERED BRAKE PADS FRONT	-	-	-	-
	BRAKE POWER DISC MHR Ø 200 FRONT BRAKE DISC thick. 4 mm	-	-	-	-
	WHOOOP DISC Ø 200 FRONT BRAKE DISC thick. 3,3 mm	-	-	-	-
	RS24 FRONT SHOCK ABSORBER	-	-	-	4614615 € 178,50
	RS24 REAR SHOCK ABSORBER	-	-	-	4614618 € 230,52

47 - CYLINDER ONLY (WITHOUT HEAD)

48 - ONLY for COSA 2: (8), 5216515 € 29,00

49 - ONLY for COSA 2: (8), 5216516 € 56,00

57 - ONLY for COSA 2: 6716721 € 180,00

58 - ONLY for COSA 2: 6716720 € 180,00

58 - ONLY for COSA 2: 6716720 € 180,00

VESPA

PX euro 0-1		PX euro 2		PX euro 3		PX euro 0-1		PX euro 2		PX euro 3		PX E		T5	
	(VLX2M)		(VLX2M)												
125 2T	125 2T	125 2T	125 2T	150 2T	150 2T	150 2T	150 2T	150 2T	150 2T	200 2T	125 2T				
3117181 € 215,25	3117181 € 215,25	3117181 € 215,25	3117181 € 215,25	3117181 € 215,25	3117181 € 215,25	3117181 € 215,25	3117181 € 215,25	-	-	-	-	-	-	-	-
-	-	-	-	-	-	-	-	3116346 € 383,00 Ø 68,5	31 5102 *47* € 359,02 Ø 65	-	-	-	-	-	-
-	-	-	-	-	-	-	-	3116349 € 409,00 Ø 68,5	-	-	-	-	-	-	-
-	-	-	-	-	-	-	-	3116129 € 399,00 Ø 68,5	-	-	-	-	-	-	-
-	-	-	-	-	-	-	-	5316082 € 382,00 Ø 16	-	-	-	-	-	-	-
-	-	-	-	-	-	-	-	5316176 € 506,00 Ø 16	-	-	-	-	-	-	-
PG.473	PG.473	PG.473	PG.473	PG.473	PG.473	PG.473	PG.473	PG.473	PG.473	PG.473	PG.473	PG.473	PG.473	PG.473	PG.473
-	-	-	-	-	-	-	-	5714493 € 630,00	-	-	-	-	-	-	-
7216456 € 137,06	7216456 € 137,06	7216456 € 137,06	7216456 € 137,06	7216456 € 137,06	7216456 € 137,06	7216456 € 137,06	7216456 € 137,06	-	-	-	-	-	-	-	-
1610600 € 228,86	1610600 € 228,86	1610600 € 228,86	1610600 € 228,86	1610600 € 228,86	1610600 € 228,86	1610600 € 228,86	1610600 € 228,86	1610701 € 248,95	-	-	-	-	-	-	-
1615895 € 298,00	1615895 € 298,00	1615895 € 298,00	1615895 € 298,00	1615895 € 298,00	1615895 € 298,00	1615895 € 298,00	1615895 € 298,00	1615550 € 321,84	1615895 € 298,00	-	-	-	-	-	-
2015896 € 160,68	2015896 € 160,68	2015896 € 160,68	2015896 € 160,68	2015896 € 160,68	2015896 € 160,68	2015896 € 160,68	2015896 € 160,68	2014913 € 160,68	2015896 € 160,68	-	-	-	-	-	-
3217138 € 170,00	3217138 € 170,00	3217138 € 170,00	3217138 € 170,00	3217138 € 170,00	3217138 € 170,00	3217138 € 170,00	3217138 € 170,00	3217143 € 170,00	-	-	-	-	-	-	-
5216505 € 20,00 (6)	5216515 € 29,00 (8)	5216515 € 29,00 (8)	5216505 € 20,00 (6)	5216515 € 29,00 (8)	5216515 € 29,00 (8)	5216515 € 29,00 (8)	5216515 € 29,00 (8)	5216511 (7) <-1997 € 22,00 5216515 (8) 1998-> € 29,00	5216511 € 22,00 (7)	-	-	-	-	-	-
5216510 € 24,50 (6)	5216516 € 56,00 (8)	5216516 € 56,00 (8)	5216510 € 24,50 (6)	5216516 € 56,00 (8)	5216516 € 56,00 (8)	5216516 € 56,00 (8)	5216516 € 56,00 (8)	5216514 (7) <-1997 € 26,00 5216516 (8) 1998-> € 56,00	5216514 € 26,00 (7)	-	-	-	-	-	-
29 4029 € 5,00 (6)	2913482 € 13,40 (8)	2913482 € 13,40 (8)	29 4029 € 5,00 (6)	2913482 € 13,40 (8)	2913482 € 13,40 (8)	2913482 € 13,40 (8)	2913482 € 13,40 (8)	29 4586 € 5,70 (7)	29 4586 € 5,70 (7)	-	-	-	-	-	-
67 3730 € 135,00	6716721 € 180,00	6716721 € 180,00	67 3730 € 135,00	6716721 € 180,00	6716721 € 180,00	6716721 € 180,00	6716721 € 180,00	67 3888 <-1997 € 135,00 6716721 1998-> € 180,00	67 3888 € 135,00	-	-	-	-	-	-
-	6716720 € 180,00	6716720 € 180,00	-	6716720 € 180,00	6716720 € 180,00	6716720 € 180,00	6716720 € 180,00	67 5235 <-1997 € 135,00 6716720 1998-> € 180,00	-	-	-	-	-	-	-
5516953 (1,2) € 310,00 5516956 (0,9) € 310,00	5516953 (1,2) € 310,00 5516956 (0,9) € 310,00	5516953 (1,2) € 310,00 5516956 (0,9) € 310,00	5516953 (1,2) € 310,00 5516956 (0,9) € 310,00	5516953 (1,2) € 310,00 5516956 (0,9) € 310,00	5516953 (1,2) € 310,00 5516956 (0,9) € 310,00	5516953 (1,2) € 310,00 5516956 (0,9) € 310,00	5516953 (1,2) € 310,00 5516956 (0,9) € 310,00	5516953 (1,2) € 310,00 5516956 (0,9) € 310,00	-	-	-	-	-	-	-
5517175 € 435,00 (1,2)	5517175 € 435,00 (1,2)	5517175 € 435,00 (1,2)	5517175 € 435,00 (1,2)	5517175 € 435,00 (1,2)	5517175 € 435,00 (1,2)	5517175 € 435,00 (1,2)	5517175 € 435,00 (1,2)	5517175 € 435,00 (1,2)	5517175 € 435,00 (1,2)	-	-	-	-	-	-
4515122 € 59,00	4515122 € 59,00	4515122 € 59,00	4515122 € 59,00	4515122 € 59,00	4515122 € 59,00	4515122 € 59,00	4515122 € 59,00	4515122 € 59,00	4515122 € 59,00	-	-	-	-	-	-
4515120 € 64,00	4515120 € 64,00	4515120 € 64,00	4515120 € 64,00	4515120 € 64,00	4515120 € 64,00	4515120 € 64,00	4515120 € 64,00	4515120 € 64,00	4515120 € 64,00	-	-	-	-	-	-
6215047 € 6,76	6215049 € 6,24	6215049 € 6,24	6215047 € 6,76	6215049 € 6,24	6215049 € 6,24	6215049 € 6,24	6215049 € 6,24	-	-	-	-	-	-	-	-
62 9088 € 6,55	6215074 € 6,30	6215074 € 6,30	62 9088 € 6,55	6215074 € 6,30	6215074 € 6,30	6215074 € 6,30	6215074 € 6,30	-	-	-	-	-	-	-	-
-	6215006 € 11,96	6215006 € 11,96	-	6215006 € 11,96	6215006 € 11,96	6215006 € 11,96	6215006 € 11,96	-	-	-	-	-	-	-	-
-	62 9078 € 79,00	62 9078 € 79,00	-	62 9078 € 79,00	62 9078 € 79,00	62 9078 € 79,00	62 9078 € 79,00	-	-	-	-	-	-	-	-
-	6212604 € 76,38	6212604 € 76,38	-	6212604 € 76,38	6212604 € 76,38	6212604 € 76,38	6212604 € 76,38	-	-	-	-	-	-	-	-
4614615 € 178,50	4614615 € 178,50	4614615 € 178,50	4614615 € 178,50	4614615 € 178,50	4614615 € 178,50	4614615 € 178,50	4614615 € 178,50	4614615 € 178,50	4614615 € 178,50	-	-	-	-	-	-
4614618 € 230,52	4615127 € 248,70	4615127 € 248,70	4614618 € 230,52	4615127 € 248,70	4615127 € 248,70	4615127 € 248,70	4615127 € 248,70	4614618 € 230,52	4614618 € 230,52	-	-	-	-	-	-



MALOSSİ

PIAGGIO - APE 50 cc



with ENGINE 

PIAGGIO

APE

50 2T



	CYLINDER+HEAD cast-iron Ø 47	31 7903
	to CRANKCASE	€ 117,66
	CYLINDER+HEAD cast-iron Ø 55	31 8691
	to CRANKCASE	€ 117,56
	CYLINDER+HEAD cast-iron Ø 57,5	31 8694
	to CRANKCASE	€ 132,54
	RADIAL BALL BEARINGS	
	for crankshaft	 PG.473
	CLUTCH DISK SET SPORT	5216520 *53*
	(SPRING)	€ 21,00 (1)
	CLUTCH DISK SET MHR	5216521 *54*
	(SPRING)	€ 26,00 (1)
	CLUTCH DISK SET MHR TEAM	5216522 *55*
	(SPRING)	€ 37,00 (1)
	CLUTCH SPRING	29 3750
		€ 4,52
	CARBURETTOR SHBC 19	72 5792
	DIRECT to CRANKCASE	€ 90,16
	CARBURETTOR KIT SHBC 19	1610910
		€ 176,22
	INTAKE MANIFOLD KIT	20 5826
	REED to CRANKCASE for SHBC 19	€ 115,44
	EXHAUST SYSTEM POWER EXHAUST	3214431
	ENGINE WITH ORIGINAL STROKE	€ 98,00
	EXHAUST SYSTEM POWER EXHAUST	3214464
	ENGINE WITH STROKE 125 cc	€ 98,00
	EXHAUST SYSTEM SCOOTER RACING MHR	3214589
	ENGINE WITH STROKE 125cc	€ 272,00



53 - ONLY for APE FL: (6), 5216523 € 22,50

54 - ONLY for APE FL: (6), 5216524 € 29,00

55 - ONLY for APE FL: (6), 5216525 € 59,00



CYLINDER KIT
Ø 47 cast-iron
31 7903



CYLINDER KIT
Ø 57,5 cast-iron
31 8694



CARBURETTOR KIT
SHBC 19
reed to crankcase + mix
1610910



CYLINDER KIT
Ø 55 cast-iron
31 8691



REINFORCED
CLUTCH SPRING
29 3750



INTAKE MANIFOLD KIT
reed to crankcase SHBC
20 5826



SHBC 19 direct to crankcase
AUTOMIX PIAGGIO
72 5792



SCOOTER RACING MHR EXHAUST SYSTEM

3214589

For vehicles with stroke 125 cc

- EXHAUST in special sheet steel (0.8/0.10 mm thickness) manufactured using robotic T.I.G. and M.I.G. welding and manual torch welding with oxy-acetaline, artiginally peened. Clear coat finish.
- SILENCER in aluminum with satin finish.



MALOSSI POWER EXHAUST EXHAUST SYSTEM

3214431

For vehicles with original stroke

3214464

For vehicles with stroke 125 cc

- Exhaust system with noise reducing chicane flow design, complete with add-on refurbish able silencer.
- Expansion chamber with internal baffling, made of FeP04 steel with added noise reducing fibreglass packing.
- Painted with high temperature resistant transparent paint.
- Exhaust system includes a complete set of brackets, collars, screws and all parts needed for assembly, interchangeable with the original exhaust without need for modifications.



**MALOSSI****Complete cylinders I-TECH 4 STROKE****Piaggio / Vespa 125-150 4T****New****Technical features**

Cylinder + CDI	Bore Ø	Stroke mm	Displacement cc	Compression ratio	CDI	MAPS
3116550	63	58,6	182,67	1:11,15	5516549	0 - 125cc with kit Malossi Ø 63 + Original exhaust system 1 - 125cc with kit Malossi Ø 63 + Malossi exhaust system with db killer 2 - 150cc with kit Malossi Ø 63 + Original exhaust system 3 - 150cc with kit Malossi Ø 63 + Malossi exhaust system with db killer
3116669	63	58,6	182,67	1:11,15	5516670B	0 - 125cc with kit Malossi Ø 63 + Original exhaust system 1 - 125cc with kit Malossi Ø 63 + Malossi exhaust system with db killer 2 - 150cc with kit Malossi Ø 63 + Original exhaust system 3 - 150cc with kit Malossi Ø 63 + Malossi exhaust system with db killer

Table of applications

3116550		3116669	
VESPA	Sprint 3V 125 ie 4T euro 3 2014	PIAGGIO	NEW FLY 3V 125 ie 4T euro 3 2012>
	Sprint 3V 150 ie 4T euro 3 2014	VESPA	946 3V ABS 125 ie 4T (M801M)
			GTS 3V 125 ie 4T LC euro 3
			GTS 3V 150 ie 4T LC euro 3
			LT 3V 125 ie 4T euro 3
			LT 3V 150 ie 4T euro 3
			S 3V 125 ie 4T euro 3 2012



New



MALOSSI

Table of applications



The models listed in the chart here below may have a different **THROTTLE BODY**, depending on the year of production/country where they are sold. Thus, they need a special cylinder equipped with cdi. When placing your order, please check the following identification numbers: country, frame number and engine number.
In case of countries which are not mentioned into below chart, you'll have to check the origin of the vehicle.

MODEL	COUNTRY	FRAME NUMBER	ENGINE NUMBER	Complete cylinders I-TECH 4 Stroke	
				Version with CDI integrated into the throttle body	Version without CDI integrated into the throttle body
PIAGGIO					
LIBERTY 3V 2013 - 2014 125	EUROPA	RP8M73400 - RP8M73401 < 01 - 2014	M737M - M739M	3116669	---
LIBERTY 3V 2013 - 2014 125	EUROPA	RP8M73400 - RP8M73401 > 01 - 2014	M737M - M739M	---	3116550
LIBERTY 3V 2013 - 2014 125	VIETNAM	RP8M73400 - RP8M73401 < 05 - 2013	M737M - M739M	3116669	---
LIBERTY 3V 2013 - 2014 125	VIETNAM	RP8M73400 - RP8M73401 > 05 - 2013	M737M - M739M	---	3116550
LIBERTY 3V 2013 - 2014 150	EUROPA	RP8M73500 - RP8M73501 < 01 - 2014	M738M - M73AM	3116669	---
LIBERTY 3V 2013 - 2014 150	EUROPA	RP8M73500 - RP8M73501 > 01 - 2014	M738M - M73AM	3116669	---
LIBERTY 3V 2013 - 2014 150	VIETNAM	RP8M73500 - RP8M73501 < 01 - 2014	M738M - M73AM	3116669	---
LIBERTY 3V 2013 - 2014 150	VIETNAM	RP8M73500 - RP8M73501 > 01 - 2014	M738M - M73AM	---	3116550
VESPA					
LX 3V 2012 - 2013 125	EUROPA	ZAPM68300 - ZAPM68303 < 06 - 2013	M687M - M68AM	3116669	---
LX 3V 2012 - 2013 125	EUROPA	ZAPM68300 - ZAPM68303 > 06 - 2013	M687M - M68AM	---	3116550
LX 3V 2013 125	TAIWAN	RP8M68300	M689M	3116669	---
LX 3V 2012 - 2013 125	VIETNAM	RP8M66500	M669M	3116669	---
LXV 3V 2013 - 2014 125	VIETNAM	RP8M66502 - RP8M66302	M669M - M689M	3116669	---
LX 3V 2012 - 2013 150	EUROPA	ZAPM68400 < 06 - 2013	M688M	3116669	---
LX 3V 2012 - 2013 150	EUROPA	ZAPM68400 > 06 - 2013	M688M	---	3116550
LX 3V 2012 - 2013 150	VIETNAM	RP8M66600	M66AM	3116669	---
LXV 3V 2013 - 2014 150	VIETNAM	RP8M66602	M66AM	3116669	---
PRIMAVERA 3V 125	EUROPA	ZAPM81100 - ZAPM81101	M811M	---	3116550
PRIMAVERA 3V 125	VIETNAM	RP8M2821 - RP8M82100	M100M - M821M	3116669	---
PRIMAVERA 3V 150	EUROPA	ZAPM81200 - ZAPM81201	M812M	---	3116550
PRIMAVERA 3V 150	USA	ZAPM818G	M812M	---	3116550
PRIMAVERA 3V 150	VIETNAM	RP8M82200 - RPM828F	M822M - M815M	3116669	---

Below pictures show the difference between the two throttle bodies.

3116669 € 530,45

Version **with** CDI integrated into the throttle body



3116550 € 530,45

Version **without** CDI integrated into the throttle body





COMPLETE CYLINDER KIT 3116268 € 1.085,00



ATTENTION: in order to install **CYLINDER KIT Ø 75,5 H2O I-TECH 4-STROKE** with **cdi** and **camshaft** on **Piaggio engines 125 ie 4T LC** produced as from **September 2014**, you need to buy below listed **PIAGGIO** products.

Original PIAGGIO products:

- Q.ty 1 - 877771 Crown chain sprocket
- Q.ty 1 - B0184845 Outlet rocker arm
- Q.ty 1 - B0184835 Intake rocker arm
- Q.ty 2 - 486343 Rocker arm shaft

Piaggio models produced as from September 2014 for which you need to buy Piaggio products:

APRILIA
SR MAX 125 ie 4T LC euro 3

GILERA
NEXUS 125 ie 4T LC euro 3

PIAGGIO
BEVERLY 125 ie 4T LC euro 3 2010 (QUASAR)
MP3 YOURBAN 4V 125 ie 4T LC euro 3 2011
X7 EVO 125 ie 4T LC euro 3 (QUASAR)

VESPA
GTS Super 125 ie 4T LC euro 3 2014 ->



V4 HEAD 3813273 € 475,00

In order to install **V4 HEAD** on **Piaggio engines 125 ie 4T LC** produced as from **September 2014**, you need to buy **Malossi camshaft**, besides **PIAGGIO** products.

Original PIAGGIO products:

- Q.ty 1 - 877771 Crown chain sprocket
- Q.ty 1 - B0184845 Outlet rocker arm
- Q.ty 1 - B0184835 Intake rocker arm
- Q.ty 2 - 486343 Rocker arm shaft



Power Cam
5911962
€ 218,53

New

COMPLETE CYLINDER KIT

Ø 75,5 H₂O

I-TECH 4-STROKE with CDI and camshaft



Monumental Achievement Malossi



3116268
€ 1.085,00

TECHNICAL CIRCULAR N° 1/2015

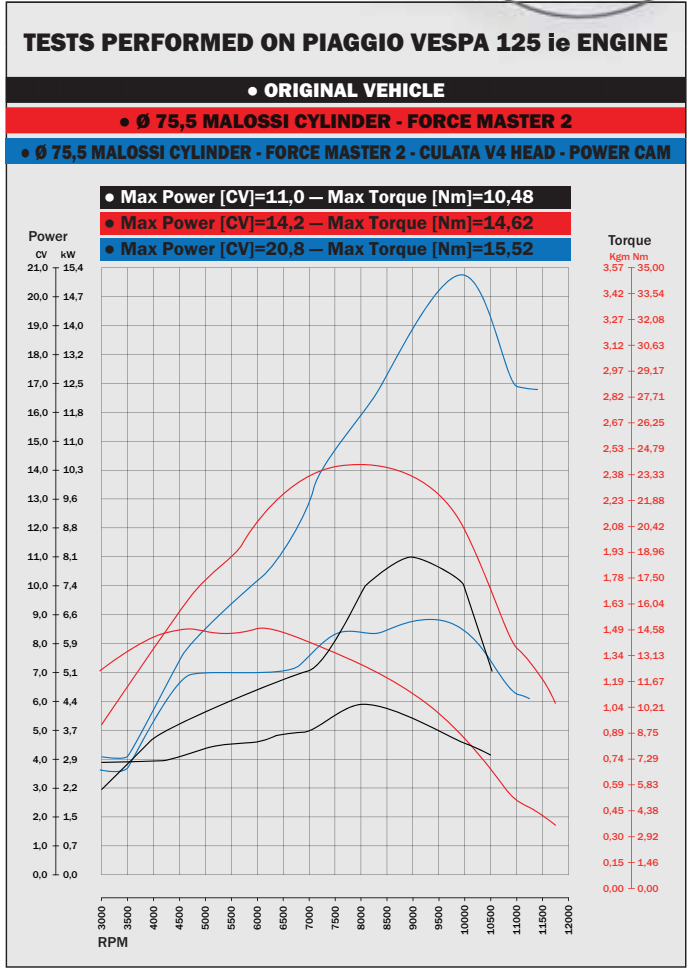

CDI FORCE MASTER 2

Carburation adjusting
± 20% at min/medium/max
RPM limiter

4 different maps :

- 0 - Malossi cylinder - Original exhaust system - Original camshaft - Original head
- 1 - Malossi cylinder - Original exhaust system - Malossi camshaft - Original head
- 2 - Malossi cylinder - Original exhaust system - Malossi camshaft - Malossi head
- 3 - Malossi cylinder - Modified exhaust system - Malossi camshaft - Malossi head



homologated exhaust system

Top Performer

The Maxi Wild Lion now they're even homologated!
Perfection in their design, silent with increased performance,
unmatched in elegance and lightweight.
Maxi Wild Lion is an exclusive Malossi product- Made in Italy.

Technical features

- European homologation
- Elliptical cross-section casing made of stainless steel with laser marked logo
- Carbon end caps
- Silencer system with the addition of sound absorbing mineral fibers, possessing high noise damping and nondegrading qualities.
- Equipped with DB killer
- Stainless steel exhaust tubes from the cylinder or to the silencer.



(*) ATTENTION: THE "TYPE" ONLY SPECIFIES THE MODEL IN WHICH HOMOLOGATION WAS VALIDATED. THIS DOES NOT LIMIT THE INSTALLATION.

WITH NUMBER 9 Homologation that respects the limits for sound level requested by the European Directive 97/24 chapter 9 annex III

WITH NUMBER 9 - 5 Homologation that respects the limits for sound level and air pollution requested by the European Directive 97/24 chapter 9 annex III and chapter 5 annex VII

THE ABSENCE OF HOMOLOGATION DOES NOT LIMIT THE PRODUCT FITTING		(S)		(K)		Casing	
		Homologated exhaust system	Silencer	Catalytic converter	Catalytic connection	Material	Anodized finish
MAXI SCOOTER	TYPE (*)						
APRILIA							
ATLANTIC SPRINT - Arrecife 400 4T LC (PIAGGIO M348M)	(N)	3217002	---	3216715B	---	Aluminium alloy	Black
ATLANTIC 500 4T LC	(N)	3217002	---	3216715B	---	Aluminium alloy	Black
SCARABEO Light 500 ie 4T LC 2007->	(N)	3217002	---	3216715B	---	Aluminium alloy	Black
SR MOTARD 125 4T euro 3	M70 var.3 ver.00	3215950	---	3215956B	---	Stainless steel	---
SRV 850 ie 4T LC euro 3 (PIAGGIO M554M)	M55 var.1 ver.03	3215536	---	---	1515623B	Stainless steel	---
BMW							
C GT 650 ie 4T LC euro 4 <-2015	C65 var.0133 ver.A	---	3215927 (R)	---	---	Stainless steel	---
C Sport 600 ie 4T LC euro 4 <-2015	C65 var.0131 ver.A	---	3215629B (R)	---	---	Stainless steel	---
C Sport 650 ie 4T LC euro 4 2016-> (652EA)	(N)	---	3217290 (R)	3216704B	---	Aluminium alloy	Black
GILERA							
FUOCO 500 ie 4T LC euro 3	(N)	3217002	---	3216715B	---	Aluminium alloy	Black
GP 800 4T LC (PIAGGIO M554M)	M55 var.1 ver.00-01	3214131	---	---	1514159B	Stainless steel	---
NEXUS 500 ie 4T LC euro 2-3	(N)	3217002	---	3216715B	---	Aluminium alloy	Black
HONDA							
SILVER WING 600 4T LC euro 0-1-2	PF01 var.1 ver.1	3212720 (L)	---	---	---	Aluminium alloy	Titanium
KYMCO							
DOWNTOWN i ABS 350 ie 4T LC euro 3 (SK64)	V2 var. 30 ver 00/10	3217035	---	3216704B	---	Aluminium alloy	Black
IMBK							
EVOLIS 400 ie 4T LC <i>New</i>	(N)	3216400	---	---	---	Aluminium alloy	Black
PIAGGIO							
BEVERLY 400 ie 4T LC euro 3 (M345M)	(N)	3217002	---	3216715B	---	Aluminium alloy	Black
BEVERLY TOURER 400 ie 4T LC euro 3 (M345M)	(N)	3217002	---	3216715B	---	Aluminium alloy	Black
BEVERLY 500 ie 4T LC euro 2-3 (05/2004->)	(N)	3217002	---	3216715B	---	Aluminium alloy	Black
BEVERLY CRUISER 500 ie 4T LC euro 3	(N)	3217002	---	3216715B	---	Aluminium alloy	Black
MP3 400 ie 4T LC euro 3 (MASTER M474M)	(N)	3217002	---	3216715B	---	Aluminium alloy	Black
MP3 500 ie 4T LC euro 3	(N)	3217002	---	3216715B	---	Aluminium alloy	Black
X8 400 ie 4T LC euro 3 (M521M)	(N)	3217002	---	3216715B	---	Aluminium alloy	Black
X9 Evolution - Street 500 4T LC	(N)	3217002	---	3216715B	---	Aluminium alloy	Black
XEvo 400 ie 4T LC euro 3 (M521M)	(N)	3217002	---	3216715B	---	Aluminium alloy	Black
SUZUKI							
BURGMAN AN 650 4T LC	WVBU-1 - WVBU-2-1	3212725	---	---	---	Aluminium alloy	Titanium
YAMAHA							
T MAX (carb.) 500 4T LC 2001->2003	SJ01 var.1 ver.1/2/3/4/7/ JX	3212721	---	---	---	Aluminium alloy	Titanium
T MAX 500 ie 4T LC 2004->2007	SJ03 - SJ03 var.1 ver.1/2/3/5/6/7	3212721	---	---	---	Aluminium alloy	Titanium
T MAX 500 ie 4T LC 2008->2011	SJ06 var.1 ver.1/2/3/5/6/7 - var.2 ver.8/9/10	3214130	---	---	1514159B	Stainless steel	---
T MAX 530 ie 4T LC 2012-> (J409E)	SJ09 var.1 ver.i/ii/iv/v/vi	3216407	---	---	1516134 (C)	Aluminium alloy	Black
X MAX 400 ie 4T LC euro 3 (H330E)	SH07 var.A ver.01	3216400	---	---	---	Aluminium alloy	Black

(C) KIT

(K) TO BE BOUGHT SEPARATELY

(L) ONLY FOR vehicles WITHOUT LAMBDA sensor

(R) ALSO AVAILABLE RACING EXHAUST MANIFOLDS KIT FOR Malossi SILENCER and ORIGINAL SILENCER

BMW C GT 650 ie 4T LC euro 3 <-2015 3215932 € 184,00

BMW C Sport 600 ie 4T LC euro 3 <-2015 3215630B € 174,00

BMW C Sport 650 ie 4T LC euro 4 2016-> (652EA) 3217286 € 202,00

ATTENTION: EVEN IF MOUNTED WITH HOMOLOGATED SILENCER. The vehicle IS NOT HOMOLOGATED

(S) SILENCER ONLY, TO ASSEMBLE WITH ORIGINAL MANIFOLD.



3214131
3215536

ATTENTION: for the ASSEMBLY REMOVE the CENTRAL STAND



3212720	€ 397,80	3214131	€ 712,98	3215950	€ 422,65 <i>New</i>	3217035	€ 479,00	3215956B	€ 134,00	1515623B	€ 380,00
3212721	€ 499,01	3215536	€ 712,98	3216400	€ 525,00	3217290	€ 460,00	3216704B	€ 150,00	1516134	€ 342,00
3212725	€ 539,67	3215629B	€ 454,41	3216407	€ 670,00			3216715B	€ 137,00		
3214130	€ 683,40	3215927	€ 460,00	3217002	€ 595,00			1514159B	€ 154,00		

Homologated RX Black exhaust system

New

Malossi is pleased to announce the new homologated RX Black exhaust systems for maxi scooters!

It's a new line of homologated exhausts, suitable for a wide range of engines (up to 400 cc).

A genuine concentrate of technology, but with a very reduced weight: an RX Black exhaust weights approximately 3.5 kg only!

This weight reduction may even reach 3 kg depending on its application.

Internal components and DB killer were completely re-designed in order to achieve the best performance, while keeping noise levels within legal limits; vibrations are reduced with three silent-blocks, and assembly is extremely simple.

A further Malossi masterpiece!!!

Technical details:

- European homologation
- Aluminum alloy silencer with black anodized finish, manifold and bracket in stainless steel alloy.
- End cap made of carbon fibre
- Weight reduction to about 3.5 kg
- Easy assembly thanks to a shaped plate and three fasteners on the silencer
- Internal parts and DB killer entirely re-designed
- Reduced vibrations and shocks from the swing arm thanks to three silent-blocks

Catalytic converter

Catalytic converters enable to obtain the homologation against air pollution.



New 3216704B € 150,00
3216715B € 137,00



WITH NUMBER 9 Homologation which respects the limits for sound level requested by the European Directive 97/24 chapter 9 annex III

WITH NUMBER 9 - 5 Homologation which respects the limits for sound level and air pollution requested by the European Directive 97/24 chapter 9 annex III and chapter 5 annex VII

MAXI SCOOTER 4T

		TYPE ATTENTION: THE "TYPE" ONLY SPECIFIES THE MODEL IN WHICH HOMOLOGATION WAS VALIDATED. THIS DOES NOT LIMIT THE INSTALLATION.	Homologated exhaust system	Catalytic converter (**)
				
HONDA	SH I 300 ie 4T LC euro 4 2015-> (NF05E)	NF05 var. 1 ver. 1/2 New	3217117 502,00	3216704B 150,00
VESPA	GTS Super 125 ie LC euro 3 (M455M) <-2013	M45 var. 3 ver. 0	3216703 502,00	3216704B 150,00
	GTS Super 125 ie LC euro 3 2014 2014->	M45 var. 3 ver. 0	3216703 502,00	3216704B 150,00
	Granturismo L - GT 200 LC (M312M)	(*)	3216703 502,00	3216704B 150,00
	GTS 250 ie LC	(*)	3216703 502,00	3216704B 150,00
	GTV 250 ie LC	(*)	3216703 502,00	3216704B 150,00
	GTS Super 300 ie LC euro 3 (QUASAR M454M)	(*)	3216703 502,00	3216704B 150,00
	GTV 300 ie LC euro 3 (QUASAR)	(*)	3216703 502,00	3216704B 150,00
	Primavera 3V 125 ie euro 3 (M811M)	M81 var. 1 ver. 0	3216551 502,00	3216715B 137,00
	Primavera 3V 150 ie euro 3 (M812M)	(*)	3216551 502,00	3216715B 137,00
	Sprint 3V 125 ie euro 3 2014	(*)	3216551 502,00	3216715B 137,00
	Sprint 3V 150 ie euro 3 2014	(*)	3216551 502,00	3216715B 137,00

(*) HOMOLOGATION PENDING - THE LACK OF HOMOLOGATION DOES NOT NECESSARILY LIMIT ITS USE.

(**) ATTENTION: THE HOMOLOGATION is considered COMPLETE only after installing the CATALYTIC CONVERTER (to be bought separately).

Toccata and Fugue in **M** major.



MALOSSI

4STROKE

Prodotto e distribuito esclusivamente per l'Europa. È vietata espressamente la sua vendita in paesi regolamentati. Non accettere responsabilità per danni causati dall'uso non autorizzato.

RX Homologated exhaust systems

4STROKE

Malossi is pleased to announce the new homologated RX exhaust systems for maxi scooters!
It's a new line of homologated exhausts suitable for a wide range of engines (up to 400 cc).

A genuine concentrate of technology, but a very reduced weight: an RX exhaust weights approximately 3.5 kg only! This weight reduction may even reach 3 kg depending on its application.

Internal components and DB killer were completely re-designed in order to achieve the best performance, but keep the noise within law limits; three silent-blocks allow to reduce vibrations, while a shaped plate and three fasteners on the silencer ensure an easy and quick assembly.
A further Malossi masterpiece!!!

WITH NUMBER 9 Homologation which respects the limits for sound level requested by the European Directive 97/24 chapter 9 annex III

WITH NUMBER 9 - 5 Homologation which respects the limits for sound level and air pollution requested by the European Directive 97/24 chapter 9 annex III and chapter 5 annex VII

ATTENTION: THE "TYPE" ONLY SPECIFIES THE MODEL IN WHICH HOMOLOGATION WAS VALIDATED. THIS DOES NOT LIMIT THE INSTALLATION.
(*) THE LACK OF HOMOLOGATION DOES NOT NECESSARILY LIMIT ITS USE.

Homologated exhaust system		Homologated exhaust system	

Model	Version	Price (€)	Price (€)	Price (€)	Price (€)
APRILIA SCARABEO Light 125 LC euro 3 (APRILIA BA03) 2009-> 2011	RB var. G ver. 00	3215522	380,00	3215522.KO	620,00
SCARABEO Light 200 ie LC euro 3 (APRILIA CA03-CB01) 2009-> 2011	RB var. H ver. 00	3215522	380,00	3215522.KO	620,00
SCARABEO Special 300 ie LC euro 3 (PIAGGIO M28RM)	VR var. G ver. 00	3215526	356,50	---	---
SPORTCITY 125 LC (PIAGGIO M281M)	VB var. 0 ver. 00/03	3214791	380,00	---	---
SPORTCITY 200 LC euro 3 (PIAGGIO M288M)	VB var. A ver. 00	3214791	380,00	---	---
SPORTCITY 250 ie 4T LC euro 3 (PIAGGIO M288M)	VB var. B ver. 00	3215964	380,00	---	---
SPORTCITY CUBE 300 ie LC euro 3 (LEADER M28LM)	VB var. L ver. 00	3215964	380,00	---	---
SR MAX 300 ie LC euro 3	M35 var.6 ver.00	3215237	380,00	3215237.KO	620,00
GILERA NEXUS 300 ie LC euro 3	M35 var.6 ver.00	3215237	380,00	3215237.KO	620,00
RUNNER ST 125 LC euro 3	M46 var.3 ver.00	3215234	380,00	3215234.KO	620,00
RUNNER ST 200 LC euro 3	M46 var.3/4 ver.00	3215234	380,00	3215234.KO	620,00
RUNNER VX 125 LC <-2005	(*)	3215263	380,00	---	---
RUNNER VX 125 LC 2006->	M46 var.3 ver.00	3215234	380,00	3215234.KO	620,00
RUNNER VXR 200 LC <-2005	M24 var.3 ver.00	3215263	380,00	---	---
RUNNER VXR 200 LC 2006->	M46 var.4 ver.00	3215234	380,00	3215234.KO	620,00
HONDA @ 125 LC	JF07-JF07 var. 1 ver. 1	3214796	380,00	---	---
@ 150 LC	KF03-KF03 var. 1 ver. 1	3214796	380,00	---	---
DYLAN 125 LC	JF10-JF10 var. 1 ver. 1	3214796	380,00	---	---
DYLAN 150 LC	KF05-KF05 var. 1 ver. 1	3214796	380,00	---	---
FORZA ABS 125 ie LC (JF60E)	JF60 var. 1/2 ver. 1	3216976	380,00	3216976.KO	553,00
PCX 125 ie LC euro 3 (JF28E) <-2011	JF28 var. 1 ver. 1	3215110	380,00	3215110.KO	620,00
PCX 125 ie LC euro 3 (JF47) 2012->	(*)	3215554	380,00	3215554.KO	620,00
PCX 150 ie 4T LC euro 3 (KF12E) <-2013	KF12 var. 1 ver. 1	3215554	380,00	3215554.KO	620,00
PCX 150 ie 4T LC euro 3 (KF19E) 2014->	(*)	3215554	380,00	3215554.KO	620,00
PS 125 ie LC euro 3	JF17-JF17 var. 1 ver. 1	3214796	380,00	---	---
PS 150 ie LC euro 3	KF09-KF09 var. 1 ver. 1	3214796	380,00	---	---
SH - SH Scoopy 125 LC	JF09-JF09 var. 1 ver. 1	3214796	380,00	---	---
SH 125 ie LC <-2008 - euro 3 2009-> (JF14E)	JF14-JF14 var. 1 ver. 1	3214796	380,00	---	---
SH i ABS 125 ie LC euro 3 (JF41E) 2013->	JF41 var. 1/2/3/4 ver. 1	3215557	380,00	3215557.KO	620,00
SH - SH Scoopy 150 LC	KF04-KF04 var. 1 ver. 1	3214796	380,00	---	---
SH 150 ie LC <-2008 - euro 3 2009-> (KF08E)	KF08-KF08 var. 1 ver. 1	3214796	380,00	---	---
SH i ABS 150 ie LC euro 3 (KF13E) 2013->	KF13 var. 1/2/3/4 ver. 1	3215557	380,00	3215557.KO	620,00
SH I - SH I Scoopy 300 ie 4T LC (NF02E) <-2014	NF02-NF05 var. 1 ver. 1/2	3214800	380,00	---	---
KAWASAKI J 300 ie LC euro 3 (WS60)	(*)	3214808	380,00	3214808.KO	620,00
KEEWAY OUTLOOK 150 LC (QJ158M.J)	T13 var. 1 ver. 1	3214796	380,00	---	---
KYMCO DINK Street 300 ie 4T LC euro 3 (SK60) - (SK60A) 2012->	V2 var. 00 ver. 00	3214808	380,00	3214808.KO	620,00
DOWNTOWN 300 ie 4T LC euro 3 (SK60) - (SK60A) 2012->	V2 var. 00 ver. 00	3214808	380,00	3214808.KO	620,00
K-XCT 300 ie LC euro 3 (SK60B)	D8 var.00 ver.00	3216641	380,00	3216641.KO	620,00
NIKITA 300 ie LC euro 3	V2 var. 00 ver. 00	3214808	380,00	3214808.KO	620,00
SUPER DINK 300 ie 4T LC euro 3 (SK60) - (SK60A) 2012->	V2 var. 00 ver. 00	3214808	380,00	3214808.KO	620,00
XCITING 250 LC euro 2	T7 var. 10 ver.00/01	3214804	380,00	---	---
XCITING - XCITING R 300 ie LC euro 3	T7 var.00/10/20 ver. all	3214804	380,00	---	---
XCITING 400 ie LC euro 3 (SK80)	D6 var.00 ver.00/01	3216388	428,00	---	---
MBK CITYLINER 125 ie LC euro 3	SE43 var. II ver. i/ii	3214827	380,00	3214827.KO	620,00
SKYCRUISER 125 ie LC euro 3	(*)	3214827	380,00	3214827.KO	620,00
PEUGEOT METROPOLIS 400 ie LC euro 3 (P6A)	X1 var. AA ver. AA	3216980	380,00	3216980.KO	553,00
SATELIS 400 4T LC euro 3 2015->	(*)	3216980	380,00	3216980.KO	553,00
SATELIS RS 400 4T LC euro 3 2015->	(*)	3216980	380,00	3216980.KO	553,00
PIAGGIO BEVERLY 250 LC euro 1-2 (M285M)	M28 var. 5 ver. 00	3214812	356,50	3214812.KO	553,00
BEVERLY 250 - S 250 ie LC euro 3	M28 var. 8 ver. 02	3214812	356,50	3214812.KO	553,00
BEVERLY 300 ie LC euro 3 (M28MM)	M28 var. A ver. 00	3214812	356,50	3214812.KO	553,00
BEVERLY 300 ie 4T LC euro 3 (M692M) 2010->	M69 var. 2 ver. 00	3214815	380,00	3214815.KO	620,00
BEVERLY TOURER 300 ie 4T LC euro 3	M28 var. A ver. 00	3214812	356,50	3214812.KO	553,00
BEVERLY Sport Touring 350 ie LC euro 3 (M693M)	M69 var. 3 ver. 00	3215157	380,00	3215157.KO	620,00
CARNABY 300 ie LC euro 3 (QUASAR)	M60 var. 4 ver. 00	3214818	339,50	3214818.KO	553,00
MP3 YOURBAN 4V 125 ie 4T LC euro 3 2011->	M71 var. 1 ver. 00	3214821	339,50	3214821.KO	553,00
MP3 YOURBAN 4V 300 ie 4T LC euro 3 2011->	M71 var. 2 ver. 00	3214821	339,50	3214821.KO	553,00
X10 350 ie LC euro 3 (M762M)	M76 var. 2 ver. 00	3215561	380,00	3215561.KO	620,00
SUZUKI BURGMAN AN K 7 > K 10 400 ie LC	WVCG 1 -1/1-2/2-1/2-4/2-5	3214834	380,00	3214834.KO	620,00
VESPA Granturismo L - GT 200 LC (M312M)	M31 var. 2 ver. 00	3214824	356,50	---	---
GTS Super 125 ie LC euro 3 <-2013 (M455M) - 2014->	(*)	3214824	356,50	---	---
GTS 250 ie LC	M45 var. 1 ver. 00	3214824	356,50	---	---
GTS Super 300 ie LC euro 3 (QUASAR M454M)	M45 var. 2 ver. 00	3214824	356,50	---	---
GTV 250 ie LC	M45 var. 1 ver. 00	3214824	356,50	---	---
GTV 300 ie LC euro 3 (QUASAR)	(*)	3214824	356,50	---	---
YAMAHA TRICITY 125 ie LC	SE78 var. A ver. 01/02/03/05/06/07	3216840	380,00	3216840.KO	620,00
X CITY 125 ie LC euro 3 (E3A5E)	SE43 var. I ver. i/ii	3214827	380,00	3214827.KO	620,00
X CITY 250 ie LC euro 3 (G358E)	SG19 var. I ver. i/ii/iii/iv	3214831	380,00	---	---
X CITY 250 ie 4T LC euro 3 (G387E) 2014->	(*)	3214831	380,00	---	---
Xenter 125 ie LC	SE59 var. I ver. ii	3216014	380,00	3216014.KO	620,00
Xenter 150 ie LC (G397E)	SG23 var. I ver. ii	3216014	380,00	3216014.KO	620,00
X MAX 125 ie LC euro 3 <-2013	SE32 var. I ver. i/ii	3214827	380,00	3214827.KO	620,00
X MAX 250 ie 4T LC euro 3 2008->	SG16 var. I ver. i - SG22 var. I ver. i	3214831	380,00	---	---

Technical details:

- European homologation
- Silencer, manifold and bracket in stainless steel alloy
- Carbon bottom plate
- Satin finish
- Weight reduction to about 3.5 kg
- Laser marked Malossi logo
- Easy assembly thanks to a shaped plate and three fasteners on the silencer
- Internal parts and DB killer entirely re-designed
- Reduced vibrations and shocks from the swing arm thanks to three silent-blocks

DB killer Racing

This racing DB killer allows to further improve the performance of the exhaust. Although it does not respect the European homologation standards, it keeps the noise within acceptable limits.





MALOSSI

HEAT MASTER

Dampens your engine's ebullient spirits

Suitable for ALL VEHICLES 50 cc LC

5516096

€ 282,00



It is significantly important to control the engine operating temperature. Not only you should know at how many degrees the engine is working, but it is important to vary its temperature depending on the different operating conditions.

Malossi understood this, thus creating **HEAT MASTER**, an electronic control system to be used with **ENERGY PUMP**, in order to adjust the engine's temperature in real time.

HEAT MASTER can be **installed on different scooter models, both two-stroke and four-stroke**. Its functions can be modified by easily working on the **trimmers** positioned on the cdi. By selecting the setting of **ENERGY PUMP** among different presets, you will set **the minimum and maximum temperatures as well as the warning lights** to be provided to the rider while riding.

Through its **HEAT MONITOR**, which can be easily installed close to the dashboard, you can **check the operating temperature** at which you want the engine to work.

HEAT MASTER turns on together with your engine and, thanks to its **sensors, it adjusts the functioning of ENERGY PUMP** in real time, thus varying RPMs so as to adapt the flow of coolant and consequently keep the engine's temperature within the parameters set by the rider.

Even in case the sensor is damaged, **HEAT MASTER** guarantees maximum reliability, thus detecting the breakdown and automatically setting **ENERGY PUMP** at its maximum power. The switch off is strictly manual, so as to **ensure engine cooling** even in case of malfunctioning.



ENERGY PUMP

Suitable for ALL VEHICLES 50 cc LC

5616363

€ 123,00



ENERGY PUMP is a water circulation pump for all liquid cooled, two and four stroke scooters and motorcycles equipped with a mechanical pump.

ENERGY PUMP can be installed as a replacement in all vehicles that use an electric pump, improving efficiency.

The new **MALOSSI ENERGY PUMP** eliminates friction loss and mechanical failures, operates silently, is easy to install, and comes complete with fuses and wiring.

A new impeller and a more powerful electric motor have allowed an increase in power of 33% compared to the previous version. The electronic management of the internal pump has been improved so as to maintain a constant power supply range between 10.5 V and 14 V.

This smart pump is equipped with an electronic card, once interfaced with a dedicated electronic control unit, can more precisely control the coolant temperature within the specified values.

These characteristics raise the **ENERGY PUMP** to a superior level. It's potential and versatility makes this a coolant pump ahead of its time.

In an internal combustion engine, good coolant circulation is a guarantee for improved efficiency, performance and durability.

SPECIFICATIONS

The pump is enclosed in a rugged PPC, a light and unbreakable polymer, resistant to high temperatures, acids and fuels.

It uses a 12V feeder supplied by the battery and has a robust electric motor with brushless excitation technology.

Traditional mechanical cooling pumps are normally driven by the crankshaft and follow the rpm of the engine.

For this reason, they are not always able to supply the correct flow for proper cooling, e.g. low engine speeds and high loads.

ENERGY PUMP is equipped with an electronic card (electronic switching WCP) which, combined with a dedicated controller, allows you to adjust the flow rate to the cooling requirements of the engine, regardless of the conditions of the engine speed and of the applied loads.

This means that the engine always operates with optimal coolant temperatures.

	Units	
Voltage Range	V	9 ÷ 15
Nominal Voltage	V	12
Pumping Capacity @ 100 mbar	L/h	1200
Current Consumption (12V, 100 mbar, 23°C)	A	1,6
Operating Temperature	°C	-40 ÷ 135
Nominal RPM (12V, 100 mbar, 23° C)	Rpm	3200
Protection Class		IP55

MALOSSI

WILD LION

**Homologated exhaust systems
for Scooters 50 2T**



New



***Gritty looking,
silent,
performing.***

Designed to complete an optimal engine thermodynamic cycle, defined at the test bench and tested on rough road paths with strong slopes.

Made of mild steel sheet, internally covered with soundproofing materials, featuring a reinforced “chicane”, epoxy-coating and aluminium die-cast heat shield.

New

MALOSSI



425

32 WILD LION EXHAUST SYSTEM

(N) THE LACK OF HOMOLOGATION DOES NOT NECESSARILY LIMIT ITS USE.		TYPE ATTENTION: THE "TYPE" ONLY SPECIFIES THE MODEL IN WHICH HOMOLOGATION WAS VALIDATED. THIS DOES NOT LIMIT THE INSTALLATION.	Homologated exhaust system 		
WITH NUMBER - 9 Respects the limits for sound level requested by the European Directive 97/24 chapter 9 annex III					
Model	TYPE	Code	€		
APRILIA	SCARABEO 50 2T (MINARELLI)	PF00 / PF01	3216585	87,00	
	SCARABEO STREET 50 2T (PIAGGIO)	TH var.G ver.05	3216582	87,00	
	SR 50 2T 1994->	LF	3216587	87,00	
	SR (carb.) 50 2T LC (PIAGGIO) 2004->	(N)	3216582	87,00	
	SR DITECH GP1 50 2T LC (PIAGGIO C361M)	TE var.0 ver.00	3216582	87,00	
	SR MOTARD 50 2T euro 2 2013->	C50 var. 2 ver. 00	3217172	95,00	
	SR NETSCAPER 50 2T LC (MINARELLI)	LC	3216587	87,00	
	SR R (carb.) 50 2T LC (PIAGGIO)	VF var.D ver.00	3216582	87,00	
	SR R FACTORY 50 2T LC (PIAGGIO C361M)	VF var.B ver.00	3216582	87,00	
	SR RACING 50 2T LC (MINARELLI)	LC	3216587	87,00	
	SR REPLICA 50 2T LC <-1999	LC	3216587	87,00	
	SR STEALTH 50 2T LC (MINARELLI)	MZ L1	3216587	87,00	
	SR WWW 50 2T	LYHO	3216587	87,00	
BENELLI	PEPE 50 2T	(N)	3216581	87,00	
CPI	OLIVER 50 2T 2003->	JR var.45 ver.4	3216592	87,00	
DERBI	VARIANT Sport 50 2T	(N)	3217172	95,00	
GILERA	EASY MOVING 50 2T	(N)	3216590	87,00	
	RUNNER 50 2T LC	C36 var.4	3216582	87,00	
	RUNNER PureJet 50 2T LC <-2005	C36 var.1	3216582	87,00	
	RUNNER SP 50 2T LC <-2005	C36 var.4	3216582	87,00	
	STORM 50 2T	(N)	3216580	87,00	
KYMCO	TYPHOON 50 2T	TEC1T	3216580	87,00	
	AGILITY R16 50 2T euro 2 (KF10B)	(N)	3216593	95,00	
	DINK 50 2T	(N)	3216593	95,00	
	PEOPLE 50 2T	(N)	3216593	95,00	
	SUPER 9 50 2T LC	(N)	3216593	95,00	
MALAGUTI	TOP BOY - COBRA 50 2T	(N)	3216593	95,00	
	F10 50 2T	ZJM39/D	3216587	87,00	
MBK	F12-PHANTOM 50 2T / 50 2T LC	ZJM41 - ZJM40/D	3216581	87,00	
	BOOSTER 50 2T euro 0-1-2	4PB	3216586	87,00	
	BOOSTER NG 50 2T euro 0-1-2	4TD	3216586	87,00	
	BOOSTER R 50 2T euro 0-1-2	4PB	3216586	87,00	
	BOOSTER ROCKET 50 2T euro 0-1	(N)	3216586	87,00	
	BOOSTER SPIRIT 50 2T euro 0-1	SA06	3216586	87,00	
	EVOLIS 50 2T	(N)	3216587	87,00	
	FLIPPER 50 2T	SA03 var.1 - ver.2	3216588	87,00	
	FORTE 50 2T	(N)	3216587	87,00	
	NITRO 50 2T LC	5BR / SA14 var.I ver.II/ver.III	3216583	87,00	
	OVETTO 50 2T	(N)	3216588	87,00	
	STUNT 50 2T euro 0-1	(N)	3216586	87,00	
	PEUGEOT	ELYSEO 50 2T	(N)	3216584	87,00
		LUDIX 50 2T	L1 AA AM / AA / BM /BA / CA	3216591	87,00
		TREKKER 50 2T	S1A	3216584	87,00
		VIVACITY 50 2T	(N)	3216584	87,00
	PGO	BIG MAX 50	(N)	3216578	87,00
PIAGGIO	LIBERTY 50 2T	C15100	3216589	87,00	
	NRG 50 2T LC	SAL1T	3216580	87,00	
	NRG MC2 50 2T LC	C4	3216580	87,00	
	NRG MC3 DD 50 2T LC	C32 var.1	3216580	87,00	
	NRG MC3 DT 50 2T	C32 var.2	3216580	87,00	
	NRG MC3 Purejet 50 2T LC	C32 var.2	3216580	87,00	
	NRG Power DD 50 2T LC	C45 var.1 ver.00	3216580	87,00	
	NRG Power Purejet 50 2T LC	C45 var.2 ver.00	3216580	87,00	
	NTT 50 2T LC	(N)	3216580	87,00	
	SFERA RESTYLING 50 2T	(N)	3216589	87,00	
	TYPHOON 50 2T 2007->2010	(N)	3216580	87,00	
	TYPHOON 50 2T euro 2 (C421M) 2013->	C50 var. 1 ver. 00	3217172	95,00	
	ZIP 50 2T	C06100	3216590	87,00	
	ZIP Fast Rider 50 2T	C06100	3216590	87,00	
	ZIP SP 50 2T LC	C06100	3216590	87,00	
VESPA	ET2 50 2T	C16100	3216579	87,00	
	LX 50 2T	(N)	3216579	87,00	
YAMAHA	AEROX 50 2T LC euro 0-1-2	5BR / SA14 var.I ver.II/ver.III	3216583	87,00	
	AXIS 50 2T	(N)	3216587	87,00	
	BW'S 50 2T euro 0-1-2	(N)	3216586	87,00	
	BW'S NG 50 2T euro 0-1	SA051	3216586	87,00	
	BW'S Original/Naked 50 2T euro 2 (A137E) 2010->	3WW-SA061-SA064	3216586	87,00	
	JOG 50 2T	(N)	3216587	87,00	
	JOG ER 50 2T	(N)	3216587	87,00	
	JOG R 50 2T	(N)	3216587	87,00	
	JOG Z 50 2T	(N)	3216587	87,00	
	NEO'S 50 2T	(N)	3216588	87,00	
	SLIDER 50 2T	(N)	3216586	87,00	
	WHY 50 2T	(N)	3216588	87,00	

MALOSSI

FLIP

**Homologated exhaust systems
for Scooters 50 2T**



New



Technical Features

EXHAUST in special sheet steel (1.5 mm thickness) manufactured through the press working process.

The exhaust features silencing baffles, aluminum alloy mounting brackets (depending on the versions) with vibration isolators. Clear-coat finish.

SILENCER in aluminum, repackable.

New

MALOSSI



427

(N) THE LACK OF HOMOLOGATION DOES NOT NECESSARILY LIMIT ITS USE.		TYPE ATTENTION: THE "TYPE" ONLY SPECIFIES THE MODEL IN WHICH HOMOLOGATION WAS VALIDATED. THIS DOES NOT LIMIT THE INSTALLATION.		Homologated exhaust system 		
WITH NUMBER - 9 Respects the limits for sound level requested by the European Directive 97/24 chapter 9 annex III						
Model	TYPE	BRACKET-material	N.B.	Code	€	
APRILIA	SCARABEO STREET 50 2T (PIAGGIO)	TH var.G ver.05	stainless steel		3216694	122,00
	SPORTCITY ONE STREET 50 2T euro 2	(N)	stainless steel		3216692	122,00
	SR (carb.) 50 2T LC 2004-> (PIAGGIO)	(N)	stainless steel		3216694	122,00
	SR DITECH GP1 50 2T LC (PIAGGIO C361M)	TE var.A/0 ver.00	stainless steel		3216694	122,00
	SR MOTARD 50 2T euro 2 2013->	C50 var. 2 ver. 00	aluminum		3216988	122,00
	SR R (carb.) 50 2T LC (PIAGGIO)	VF var.D ver.00	stainless steel		3216694	122,00
	SR R FACTORY 50 2T LC (PIAGGIO C361M)	VF var.B ver.00	stainless steel		3216694	122,00
BENELLI	PEPE LX 50 2T euro 2 (QJ1E40QMB-4)	(N)	stainless steel	(M)	3216986	122,00
CPI	ARAGON GP 50 2T	(N)	stainless steel	(M)	3216986	122,00
	HUSSAR 50 2T 2003->	(N)	stainless steel	(M)	3216986	122,00
	OLIVER 50 2T 2003->	(N)	stainless steel	(M)	3216986	122,00
	POPCORN 50 2T 2003->	(N)	stainless steel	(M)	3216986	122,00
DERBI New	VARIANT Sport 50 2T 2013->	(N)	aluminum		3216988	122,00
EXPLORER	CRACKER 50 2T 2003-> (GE 1E 400 MB)	(N)	stainless steel	(M)	3216986	122,00
GARELLI	GSP 50 2T LC euro 2 (1PE40MB)	(N)	stainless steel	(M)	3216986	122,00
GILERA	RUNNER 50 2T LC	C36 var.4	stainless steel		3216692	122,00
	RUNNER PureJet 50 2T LC <-2005	C36 var.1	stainless steel		3216692	122,00
	RUNNER SP 50 2T LC <-2005	C36 var.4	stainless steel		3216692	122,00
	STALKER 50 2T	C40 var.1 ver.00	stainless steel		3216692	122,00
	TYPHOON 50 2T	TEC1T	stainless steel		3216692	122,00
HUPPER	MONTECARLO 30 50 2T (1E40QMB)	(N)	stainless steel	(M)	3216986	122,00
KYMCO	AGILITY R16 50 2T euro 2 (KF10B)	KF10BA	aluminum		3217170	122,00
	DINK 50 2T	(N)	aluminum		3217170	122,00
	PEOPLE 50 2T	B1 ver.20	aluminum	New	3217170	122,00
	SUPER 9 50 2T LC	(N)	aluminum		3217170	122,00
	TOP BOY - COBRA 50 2T	(N)	aluminum		3217170	122,00
MALAGUTI	F10 WAP 50 2T euro 2 (QJ*CMA03C*)	(N)	stainless steel	(M)	3216986	122,00
	F12-PHANTOM 50 2T	ZJM40D	stainless steel		3216986	122,00
	F12-PHANTOM 50 2T LC	ZJM41	stainless steel		3216986	122,00
	F12 DIGIT KAT-PHANTOM 50 2T LC	62 var. 01 ver. 02 / 47 var. 01 ver. 02	stainless steel		3216986	122,00
	F12 R ARIA 50 2T euro 2 (QJ*CMA02C*)	(N)	stainless steel	(M)	3216986	122,00
MBK	BOOSTER R 50 2T euro 0-1-2	4PB	aluminum		3216693	122,00
	BOOSTER NG 50 2T euro 0-1-2	4TD	aluminum		3216693	122,00
	BOOSTER SPIRIT 50 2T euro 0-1	SA06	aluminum		3216693	122,00
	NITRO 50 2T LC	5BR - SA14 var.I ver.ii/ver.iii	aluminum		3216691	122,00
PIAGGIO	LIBERTY 50 2T	C37 var.2	stainless steel		3216692	122,00
	NRG MC3 DD 50 2T LC	C32 var.1	stainless steel		3216692	122,00
	NRG MC3 Purejet 50 2T LC	C32 var.2	stainless steel		3216692	122,00
	NRG Power DD 50 2T LC	C45 var.1 ver.00	stainless steel		3216692	122,00
	NRG Power Purejet 50 2T LC	C45 var.2 ver.00	stainless steel		3216692	122,00
	TYPHOON 50 2T euro 2 (C421M) 2013->	C50 var. 1 ver. 00	aluminum		3216988	122,00
YAMAHA	AEROX 50 2T LC euro 0-1-2	5BR - SA14 var.I ver.ii/ver.iii	aluminum		3216691	122,00
	BW'S 50 2T euro 0-1-2	3WW - SA061 - SA064	aluminum		3216693	122,00
	BW'S NG 50 2T euro 0-1-2	SA051	aluminum		3216693	122,00
	BW'S Original/Naked 50 2T euro 2 2010-> (A137E)	3WW - SA061 - SA064 - SA051	aluminum		3216693	122,00
	JOGRR 50 2T LC euro 2	(N)	aluminum		3216691	122,00

(M) to be assembled EXCLUSIVELY with MALOSSİ CYLINDERS

32 FLIP EXHAUST SYSTEM

New



MHR
MALOSSİ HYPER RACING

Scooter Racing Exhaust System



Products to be used exclusively for racing in places specially designed for such activity according to the regulations of the competent sporting authorities. We accept no liability resulting from improper use.

New



MHR[®]

MALOSSI HYPER RACING

Scooter Racing Exhaust System

The perfect musical instrument to make your Malossi motor sing

Scooter Racing Malossi exhausts are designed and built with one objective: maximum possible performance **tuned to the cylinders for which they were designed**. Every evolution of Malossi exhaust systems is the result of fluid dynamic research which establishes the ideal shape and size of Scooter Racing exhausts with precision.

Only perfect exhausts with a completely uniform production process can proudly display the Malossi brand. Indeed, the production technology is applied to all Scooter Racing models, the only differences between them being **the divergence of the cones**.

All Scooter Racing exhausts are made from **sheet metal of a precise and constant thickness of 0.8 mm**, are laser cut and welded with pinpoint precision, and have a calibrating nozzle whose size respects the minute tolerances needed to maintain pressure inside the silencer at the correct levels.

The development of Scooter Racing exhausts advances at the same rate as Malossi cylinders and **in order to get the best performance, it is important to match the exhaust to the cylinder for which it was designed**.

All Scooter Racing are fitted with **aluminium silencers, anodized in Nitro Blue**.

MHR TEAM 3 and MHR BIG BORE Ø 52

MHR Team 3 and MHR Big Bore Ø 52 are the NEW Scooter Racing exhaust names designed for Testa Rossa Flanged Mount cylinders, 70 and 94 cc respectively, and are characterised by an unprecedented cone profile, now rotated vertically, for an even more dynamic appearance.

Malossi engineers have managed to considerably increase power and have paid particular attention to rounding of its usage range, in order to increase the field of action and fine tune the assembly more quickly. There is a high rev range for the motor and **the best power levels are achieved at 14,100 rpm for the 70cc, and 13,800 rpm for the 94cc**.

The assembly system on the cylinder **uses an attachment with four light alloy holes**, designed to allow a perfect flow of exhaust gases, and so optimising fluid dynamic flow. This solution is a direct development of the technology used by the MHR Team 2 exhaust, where as it is unprecedented on the Big Bore Ø 52 version.

The connection system for the **Nitro blue** anodized aluminium silencer has been simplified, and is now linked to the expansion chamber in a light and elegant way, using only one holding screw.



Code	Prices
32 7561	272,00
32 7562	266,00
32 9027	314,23
32 9612	345,00
32 9834	377,08
3212115	377,20
3212965	377,20
3214589	272,00
3214763	366,18
3215134	366,18
3215198	366,18
3215341	366,18
3216158	366,18
3216827	366,18

SCOOTER RACING EXHAUST SYSTEM

		MHR	TEAM Ø 47,6	TEAM 2 Ø 47,6	TEAM 3 Ø 47,6 New	BIG BORE 2 Ø 50	BIG BORE Ø 52 New
For CYLINDERS		MHR Ø 47 - 47,6	TEAM Ø 47,6	TEAM - TEAM 2 Ø 47,6	TEAM 2 - FLANGED MOUNT testa rossa Ø 47,6	Ø 50 BIG BORE	BIG BORE - FLANGED MOUNT testa rossa Ø 52
SCOOTER							
APRILIA	AMICO 50 2T	32 7561	---	---	---	---	---
	AREA 51 50 2T LC	---	---	---	---	3215198	3216827
	GULLIVER 50 2T LC	32 7562	---	3214763	---	3215198	3216827
	RALLY 50 2T (MINARELLI)	32 7562	---	3214763	---	---	---
	RALLY 50 2T LC (MINARELLI)	32 7562	---	3214763	---	---	---
	SCARABEO 50 2T (MINARELLI)	---	---	3214763	---	---	---
	SCARABEO STREET 50 2T (PIAGGIO)	32 9834	---	---	---	---	---
	SONIC 50 2T	---	---	3214763	---	---	---
	SONIC 50 2T LC	---	---	3214763	---	3215198	3216827
	SPORTCITY ONE STREET 50 2T euro 2	32 9834	---	---	---	---	---
	SR 50 2T <-1993	32 7561	---	---	---	---	---
	SR (carb.) 50 2T LC 2004 (PIAGGIO)	---	3212115	---	3215341	3215134	3216158
	SR 50 2T 1994->	32 7562	---	3214763	---	---	---
	SR MOTARD 50 2T euro 2	32 9027	---	---	---	---	---
	SR NETSCAPER 50 2T LC (MINARELLI)	---	---	3214763	---	3215198	3216827
	SR R (carb.) 50 2T LC (PIAGGIO)	---	3212115	---	3215341	3215134	3216158
	SR RACING 50 2T LC (MINARELLI)	---	---	3214763	---	3215198	3216827
	SR REPLICIA 50 2T LC	---	---	3214763	---	3215198	3216827
	SR STEALTH 50 2T LC (MINARELLI)	---	---	3214763	---	3215198	3216827
	SR WWW 50 2T	---	---	3214763	---	---	---
BENELLI	491 GT 50 2T (MINARELLI)	32 7562	---	3214763	---	---	---
	491 SPORT 50 2T LC (MINARELLI)	32 7562	---	3214763	---	3215198	3216827
	K2 50 2T	32 7562	---	3214763	---	---	---
	K2 50 2T LC	---	---	3214763	---	---	---
	NAKED 50 2T	32 7562	---	3214763	---	---	---
	PEPE LX 50 2T euro 2 (QJ1E40QMB-4)	32 7562	---	3214763	---	---	---
	QuattronoveX 50 2T euro 2	32 7562	---	3214763	---	---	---
BETA	ARK 50 2T	---	---	3214763	---	---	---
	ARK 50 2T LC	---	---	3214763	---	---	---
	EIKON 50 2T LC	32 7562	---	3214763	---	3215198	3216827
	QUADRA 50 2T	32 7562	---	3214763	---	---	---
BSV	AX 50	32 7562	---	---	---	---	---
	GZ 50	32 7562	---	---	---	---	---
CPI	ARAGON GP 50 2T	32 7562	---	3214763	---	---	---
	HUSSAR 50 2T <-2002 (50 C)	32 7562	---	3214763	---	---	---
	HUSSAR 50 2T 2003->	32 7562	---	3214763	---	---	---
	OLIVER 50 2T <-2002 (50 C)	32 7562	---	3214763	---	---	---
	OLIVER 50 2T 2003->	32 7562	---	3214763	---	---	---
	POPCORN 50 2T <-2002 (50 C)	32 7562	---	3214763	---	---	---
	POPCORN 50 2T 2003->	32 7562	---	3214763	---	---	---
DERBI	ATLANTIS - BULLET 50 2T 2003->	32 9027	---	---	---	---	---
	GP1 50 2T LC	32 9027	---	---	3215341	3215134	3216158
	GP1 OPEN 50 2T LC	32 9027	3212115	---	3215341	3215134	3216158
	GP1 REVOLUTION 50 2T LC	3212965	---	---	3215341	3215134	3216158
EXPLORER	CRACKER 50 2T 2003-> (GE 1E 400 MB)	32 7562	---	3214763	---	---	---
FANTIC	BIG WHEEL 50 2T	32 7561	---	---	---	---	---
GARELLI	TIESSE 50R 50 2T euro 2 (1E40QMB)	32 7562	---	3214763	---	---	---
GILERA	DNA 50 2T LC	32 9027	---	---	3215341	3215134	3216158
	EASY MOVING 50 2T	32 9834	---	---	---	---	---
	ICE 50 2T	32 9027	---	---	---	---	---
	RUNNER 50 2T LC	32 9027	3212115	---	3215341	3215134	3216158
	RUNNER SP 50 2T LC <-2005	32 9027	3212115	---	3215341	3215134	3216158
	RUNNER SP (carb.) 50 2T LC 2006-> (C451M)	32 9027	3212115	---	3215341	3215134	3216158
	STALKER 50 2T	32 9027	---	---	---	---	---
	STORM 50 2T	32 9027	---	---	---	---	---
	TYPHOON 50 2T	32 9027	---	---	---	---	---
	TYPHOON X 50 2T	32 9027	---	---	---	---	---
	HUPPER	MONTECARLO 30 50 2T (1E40QMB)	32 7562	---	3214763	---	---
ITALJET	DRAGSTER 50 2T LC	---	---	---	---	3215198	3216827
	JET SET 50 2T	32 9027	---	---	---	---	---
	SCOOP 50 2T	32 7561	---	---	---	---	---
	YANKEE 50 2T	32 7561	---	---	---	---	---
KEEWAY	F-ACT 50 2T	32 7562	---	3214763	---	---	---
	GOCCIA 50 2T (KW1E40QMB-4)	32 7562	---	3214763	---	---	---
	HURRICANE 50 2T euro 2 (KW1E40QMB)	32 7562	---	3214763	---	---	---
	MATRIX 50 2T (KW1E40QMB-4)	32 7562	---	3214763	---	---	---
	PIXEL 50 2T euro 2 (KW1E40QMB)	32 7562	---	3214763	---	---	---
	RY8 50 2T (KW1E40QMB-4)	32 7562	---	3214763	---	---	---
MALAGUTI	F10 50 2T	32 7562	---	3214763	---	---	---
	F10 WAP 50 2T euro 2 (QJ*CMA03C*)	32 7562	---	3214763	---	---	---
	F12 DIGIT KAT-PHANTOM 50 2T LC	---	---	3214763	---	3215198	3216827
	F12 DIGIT KAT-PHANTOM 50 2T LC euro 2	---	---	3214763	---	3215198	3216827
	F12 R ARIA 50 2T euro 2 (QJ*CMA02C*)	32 7562	---	3214763	---	---	---
	F12 R LC 50 2T LC euro 2	---	---	3214763	---	3215198	3216827
	F12-PHANTOM 50 2T	---	---	3214763	---	---	---
	F12-PHANTOM 50 2T LC	---	---	3214763	---	3215198	3216827
	F15 FIREFOX 50 2T LC	---	---	3214763	---	3215198	3216827
	YESTERDAY 50 2T	---	---	3214763	---	---	---

		MHR	TEAM Ø 47,6	TEAM 2 Ø 47,6	TEAM 3 Ø 47,6 New	BIG BORE 2 Ø 50	BIG BORE Ø 52 New	
For CYLINDERS		MHR Ø 47 - 47,6	TEAM Ø 47,6	TEAM - TEAM 2 Ø 47,6	TEAM 2 - FLANGED MOUNT testa rossa Ø 47,6	Ø 50 BIG BORE	BIG BORE - FLANGED MOUNT testa rossa Ø 52	
MBK	BOOSTER 50 2T euro 0-1	32 7561	---	---	---	---	---	
	BOOSTER 50 2T euro 2 (A137E)	32 7561	---	---	---	---	---	
	BOOSTER NAKED 50 2T euro 2 (A137E)	32 7561	---	---	---	---	---	
	BOOSTER NG 50 2T euro 0-1	32 7561	---	---	---	---	---	
	BOOSTER NG 50 2T euro 2 (A137E)	32 7561	---	---	---	---	---	
	BOOSTER ROCKET 50 2T euro 0-1	32 7561	---	---	---	---	---	
	BOOSTER ROCKET 50 2T euro 2 (A137E)	32 7561	---	---	---	---	---	
	BOOSTER SPIRIT 50 2T euro 0-1	32 7561	---	---	---	---	---	
	EVOLIS 50 2T	32 7562	---	---	3214763	---	---	---
	FIZZ 50 2T	32 7562	---	---	3214763	---	---	---
	FLIPPER 50 2T	32 7562	---	---	3214763	---	---	---
	FORTE 50 2T	32 7562	---	---	3214763	---	---	---
	HOT CHAMP 50 2T	32 7562	---	---	3214763	---	---	---
	MACH G 50 2T	32 7562	---	---	3214763	---	---	---
	MACH G 50 2T LC	---	---	---	3214763	---	3215198	3216827
	NITRO 50 2T LC	---	---	---	3214763	---	3215198	3216827
	OVETTO 50 2T	32 7562	---	---	3214763	---	---	---
	SORRISO 50 2T 1996->	32 7562	---	---	3214763	---	---	---
	STUNT 50 2T euro 0-1	32 7561	---	---	---	---	---	---
	STUNT 50 2T euro 2	32 7561	---	---	---	---	---	---
	MOTRON	SYNCRO 50	32 7562	---	---	---	---	---
		THUNDER'S 50	32 7562	---	---	---	---	---
	PIAGGIO	DIESIS 50 2T	32 9027	---	---	---	---	---
FLY 50 2T		32 9834	---	---	---	---	---	
FREE 50 2T		32 9834	---	---	---	---	---	
LIBERTY 50 2T		32 9834	---	---	---	---	---	
NRG 50 2T LC		32 9027	3212115	---	---	3215341	3215134	3216158
NRG EXTREME 50 2T		32 9027	---	---	---	---	---	---
NRG EXTREME 50 2T LC		32 9027	3212115	---	---	3215341	3215134	3216158
NRG MC2 50 2T LC <-1997		32 9027	3212115	---	---	3215341	3215134	3216158
NRG MC2 50 2T LC 1998->		32 9027	3212115	---	---	3215341	3215134	3216158
NRG MC3 DD 50 2T LC		32 9027	3212115	---	---	3215341	3215134	3216158
NRG MC3 DT 50 2T		32 9027	---	---	---	---	---	---
NRG Power DD 50 2T LC		32 9027	3212115	---	---	3215341	3215134	3216158
NRG Power DT 50 2T (C453M)		32 9027	---	---	---	---	---	---
NTT 50 2T LC		32 9027	3212115	---	---	3215341	3215134	3216158
QUARTZ 50 2T LC		32 9834	3212115	---	---	3215341	3215134	3216158
SFERA 50 2T		32 9834	---	---	---	---	---	---
SFERA RESTYLING 50 2T		32 9834	---	---	---	---	---	---
TYPHOON 50 2T 2007->2010		32 9027	---	---	---	---	---	---
TYPHOON 50 2T euro 2 2011 (C421M)		32 9027	---	---	---	---	---	---
ZIP 50 2T		32 9834	---	---	---	---	---	---
ZIP 50 2T 2000		32 9834	---	---	---	---	---	---
ZIP Fast Rider 50 2T		32 9834	---	---	---	---	---	---
ZIP SP 50 2T LC <-2000		32 9834	3212115	---	---	3215341	3215134	3216158
ZIP SP 50 2T LC 2001->	32 9834	3212115	---	---	3215341	3215134	3216158	
YAMAHA	AEROX 50 2T LC euro 0-1	---	---	3214763	---	3215198	3216827	
	AEROX 50 2T LC euro 2	---	---	3214763	---	3215198	3216827	
	AXIS 50 2T	32 7562	---	3214763	---	---	---	
	BREEZE 50 2T	32 7562	---	3214763	---	---	---	
	BW'S 50 2T euro 0-1	32 7561	---	---	---	---	---	
	BW'S 50 2T euro 2 (A137E)	32 7561	---	---	---	---	---	
	BW'S NG 50 2T euro 0-1	32 7561	---	---	---	---	---	
	BW'S NG 50 2T euro 2 (A137E)	32 7561	---	---	---	---	---	
	BW'S Original/Naked 50 2T euro 2 2010 (A137E)	32 7561	---	---	---	---	---	
	JOG 50 2T	32 7562	---	3214763	---	---	---	
	JOG ER 50 2T	32 7562	---	3214763	---	---	---	
	JOG R 50 2T	32 7562	---	3214763	---	---	---	
	JOG Z 50 2T	32 7562	---	3214763	---	---	---	
	JOGRR 50 2T LC euro 2	---	---	3214763	---	3215198	3216827	
	NEO'S 50 2T	32 7562	---	3214763	---	---	---	
	SLIDER 50 2T	32 7561	---	---	---	---	---	
	SPY 50 2T	32 7561	---	---	---	---	---	
WHY 50 2T	32 7562	---	3214763	---	---	---		
ZEST 50 2T	32 7562	---	3214763	---	---	---		
ZUMA 50 2T	32 7561	---	---	---	---	---		
MAXI SCOOTER								
RUNNER	FX 125 2T LC	32 9612	---	---	---	---	---	
	FXR - SP 180 2T LC	32 9612	---	---	---	---	---	
ITALJET	DRAGSTER 125 2T LC	32 9612	---	---	---	---	---	
	DRAGSTER 180 2T LC	32 9612	---	---	---	---	---	
APE								
PIAGGIO	APE 50 2T (for vehicles with 125cc STROKE)	3214589	---	---	---	---	---	
ATV-QUAD								
DRR	DRX 90 2T	---	---	---	---	---	3216827	

MHR REPLICA HOMOLOGATED EXHAUST SYSTEM



The engineers at Malossi R&D Department have improved the vehicles performance according to laws and regulations after strict testing with sophisticated and modern equipment.

The GP MHR REPLICA exhaust systems address a sporting and demanding customer; they personalize your vehicle with elegance and with a "performance sound", completing the thermodynamic cycle of the famous Malossi MHR REPLICA cylinder kit.

TECHNICAL FEATURES

EXHAUST in special sheet steel (1 mm thickness) manufactured using robotic T.I.G. and M.I.G. welding of cone sections. The exhaust feature silencing baffles, aluminium alloy mounting brackets with vibration isolaters. Clear-coat finish.

SILENCER in aluminum, anodized in Nitro blue.



(*) ATTENTION: THE "TYPE" ONLY SPECIFIES THE MODEL IN WHICH HOMOLOGATION WAS VALIDATED. THIS DOES NOT LIMIT THE INSTALLATION.

GP MHR REPLICA for MOTO



MOTO 50 2t LC	engine	TYPE (*)	€	Homologated exhaust system
APRILIA	RS (MINARELLI AM 3 > 6)	SE	211,09	3212665
	RS4 euro 2 (DERBI)	(**)	211,09	3215230
	TUONO (MINARELLI AM 6)	SE var. A ver.00 - SE var. 0 ver.00	211,09	3212665
DERBI	GPR NUDE <-2005 (EBS050)	GR1 A1 B1	228,35	3212793
	GPR R euro 2 2012-> (DERBI)	(**)	211,09	3215230
	GPR RACING <-2003 (EBE050 - EBS050)	GPRR	189,50	3212667
	GPR RACING 2004-> (EBS050)	GR1 A1 B1	228,35	3212793
MBK	X-POWER (MINARELLI AM 6)	4YV	211,09	3213278
PEUGEOT	XR6 (MINARELLI AM 6)	LPE11C109018	211,09	3212669
RIEJU	RS2 (MINARELLI AM 6)	LSJ11C10E014	211,09	3212666
YAMAHA	TZR (MINARELLI AM 6)	RA ver.0 var.3 - RA03 - RA03 ver.I var.i	211,09	3213278

()** NOT HOMOLOGATED - THE LACK OF HOMOLOGATION DOES NOT NECESSARILY LIMIT ITS USE



SUPERMOTO MHR REPLICA



MOTO 50 2T LC	engine	TYPE (*)	€	Homologated exhaust system
APRILIA MX	(MINARELLI AM 6)	ST var. 0 ver.00 / ver.01- ST var. A ver.00 / ver.01- ST var. B ver.00 - ST var. C ver.00 - ST var. D ver.00	211,09	3212670
	RX 2007-> (DERBI D50B0)	PV var.0 ver.00	234,15	3213491
	SX 2007-> (DERBI D50B0)	PV var.A ver.00	234,15	3213491
DERBI SENDA	(EBE050 - EBS050)	SDR0AB- SDR0BB- SDR1AB- SDR1BB- SDR1CB- SDR1DB- SEND0A- SEND0B	211,09	3212668
	Senda DRD PRO R - SM (D50B0)	SA2A1A	234,15	3213488
	Senda DRD RACING R - SM (D50B0)	(**)	211,09	3212668
	Senda EVO SM (D50B0)	(**)	211,09	3212668
	Senda X-RACE R - X-RACE SM (D50B0)	(**)	211,09	3212668
	Senda X-TREME R - X-TREME SM (D50B0)	(**)	211,09	3212668
GILERA	RCR - SMT (DERBI D50B0)	(**)	211,09	3212668
HM	CR E DERAPAGE (MINARELLI AM 6)	HM 50S var. AM ver.M	211,09	3212671
	CRE SIX Comp. 50 ie 2T LC 2013-> (MINARELLI AM 6)	HM 50S var. AM ver.M	211,09	3212671

()** NOT HOMOLOGATED - THE LACK OF HOMOLOGATION DOES NOT NECESSARILY LIMIT ITS USE



GP MHR for MOTO

The Racing Exhaust developed on the racetrack for the racetrack.

It is one of the essential components intended for **MALOSSI trophy**, studied especially to increase the power of the engine at medium and high regimes. The Malossi Trophies are raced in all the world according to precise rules that require different Special Malossi Racing products for each category. This insures an optimum and homogeneous result for the various participants while utilizing the most advanced technologies.

With the **GP MHR** exhaust systems Malossi expands its range of trophy exhaust systems, that represents the highest performances in the sector.

Another Malossi' initiative which provides an opportunity for the young to participate in a two-wheeled sport and become the riders of the future.

TECHNICAL FEATURES

- **EXHAUST** in special sheet steel (0.8/0.10 mm thickness) manufactured using robotic T.I.G. and M.I.G. welding and manual torch welding with oxy-acetalline, artiginally peened. Clear coat finish.
- **SILENCER** in aluminum, anodized in Nitro blue.



MOTO 50 2T LC		engine		Code	€
APRILIA	RS	(MINARELLI AM 3 > 6)	(**)	3212222	311,89
	RS euro 2 2006->	(DERBI D50B1)	(**)	3212613	327,60
	TUONO	(MINARELLI AM 6)	(**)	3212222	311,89
DERBI	GPR NUDE <-2005	(EBS050)	(**)	3212613	327,60
	GPR NUDE 2006->	(D50B0)	(**)	3212613	327,60
	GPR RACING <-2003	(EBE050 - EBS050)	(***)	3212209	311,89
	GPR RACING 2004->2005	(EBS050)	(**)	3212613	327,60
	GPR RACING 2006->	(D50B0)	(**)	3212613	327,60
MBK	X-POWER	(MINARELLI AM 6)		3212211	311,89
PEUGEOT	XR6	(MINARELLI AM 6)		3212214	280,00
RIEJU	RS2	(MINARELLI AM 6)		3212223	280,00
YAMAHA	TZR	(MINARELLI AM 6)		3212211	311,89

(**) for MALOSSI CYLINDER

(***) ALSO for ORIGINAL CYLINDER

SUPERMOTO MHR



MOTO 50 2T LC		engine		Code	€
APRILIA	RX - SX 2007->	(DERBI D50B0)		3211982	378,72
BETA	ENDURO RR	(MINARELLI AM 6)		3212284	378,72
	SUPERMOTARD RR	(MINARELLI AM 6)		3212284	378,72
	SUPERMOTARD RR ALU	(MINARELLI AM 6)		3212336	346,80
DERBI	SENDA	(EBE050 - EBS050)	(*)	3211982	378,72
	Senda DRD PRO R - SM	(D50B0)	(*)	3213140	378,72
	Senda DRD RACING R - SM	(D50B0)		3211982	378,72
	Senda EVO SM	(D50B0)		3211982	378,72
	Senda X-RACE R - X-RACE SM	(D50B0)		3211982	378,72
	Senda X-TREME R - X-TREME SM	(D50B0)		3211982	378,72
GILERA	RCR - SMT	(DERBI D50B0)		3211982	378,72
HM	DERAPAGE RR 11	(MINARELLI AM 6)		3214576	378,72
HUSQVARNA	CH RACING	(MINARELLI AM 6)		3212339	378,72
SHERCO	HRD	(MINARELLI AM 6)		3212340	340,00

(*) ALSO for ORIGINAL CYLINDER

Homologated EXHAUST SYSTEM

Beautiful! Technologically perfect: with their strong character and such an aggressive shape, they give a touch of "High-Class" to the maxi scooter enhancing it in a superlative way.

Thanks to the great development of Malossi technical staff (utilizing the most up-to-dated labs) and to the extensive racing experience, Malossi wanted to make a significant difference by incorporating the following design requirements to the new **GP MHR REPLICA 4-Stroke** exhaust system: innovative look, performance, lightness, reliability and QUALITY.



Technical features

- European homologation
- Elliptical cross-section casing made of aluminium with black anodized finish and laser marked logo
- Carbon end caps
- Silencer system with the addition of sound absorbing mineral fibers, possessing high noise damping and nondegrading qualities.
- Equipped with DB killer
- Stainless steel exhaust tubes from the cylinder or to the silencer.

The final assembly utilizes stainless steel riveted clamps producing a sealing area of exceptional mechanical strength in turn eliminating any exhaust gas leakage.



The **GP MHR REPLICA 4-Stroke** Exhaust Systems come complete with all the necessary mounting hardware and gaskets.

WITH NUMBER 9
WITH NUMBER 9 - 5

Homologation that respects the limits for sound level requested by the European Directive 97/24 chapter 9 annex III

Homologation that respects the limits for sound level and air pollution requested by the European Directive 97/24 chapter 9 annex III and chapter 5 annex VII

(*) ATTENTION: THE "TYPE" ONLY SPECIFIES THE MODEL IN WHICH HOMOLOGATION WAS VALIDATED. THIS DOES NOT LIMIT THE INSTALLATION.

				(**)	Casing	
MOTO 125 4T LC	TYPE (*)	Homologated exhaust system	Homologated exhaust system	Catalytic Connection	Material	Anodized finish
HONDA CBR R GROM (U.S.A.) ie MSX ie	JC34	3213306			Aluminium alloy	Titanium
	JC61 Var.1 Ver.1	3216365	3216365.K0		Aluminium alloy	Black
	JC61 Var.1 Ver.1				Aluminium alloy	Black
KTM DUKE ie	A2	3215202		1515208B	Stainless steel	---
YAMAHA MT-125 ie 4T LC New YZF-R ie euro 3 <- 2013 YZF-R ie euro 3 2014 ->	RE11 var.A/B ver.01/02	3213844		1514034B	Stainless steel	---
	RE06 var.1 ver.1/11	3213844		1514034B	Stainless steel	---
	RE11 var.A ver.01/02	3216646		1514034B	Stainless steel	---

() ATTENTION: THE HOMOLOGATION is considered COMPLETE only after installing the CATALISE CONVERTER (to be bought separately).**

3213306	€ 360,36	3215202	€ 465,50	3216365.K0	€ 731,00	1514034B	€ 127,00
3213844	€ 440,00	3216365	€ 493,00	3216646	€ 440,00	1515208B	€ 126,14

Soundproof fiberglass element for high temperature.

1411728B € 8,35



For silencers Ø 60

1411745B € 10,86



For silencers Ø 70

Two versions available:

Code	Silencers	Exhaust system
1411728B	for silencers Ø 60	3212209 GP MHR
		3212211 GP MHR
		3212214 GP MHR
		3212222 GP MHR
		3212223 GP MHR
		3214764 QUAD RACING MHR BIG BORE
		3212825 DISMANTLED MHR TEAM
		3212965 SCOOTER RACING MHR TEAM
		3211982 SUPERMOTO MHR
		3212284 SUPERMOTO MHR
		3212336 SUPERMOTO MHR
		3212339 SUPERMOTO MHR
		3212340 SUPERMOTO MHR
		3212412 SUPERMOTO MHR
		3213140 SUPERMOTO MHR
		3213480 SUPERMOTO MHR
		3215134 MHR BIG BORE II
		3215198 MHR BIG BORE II
		3214762 MHR TEAM II
		3214763 MHR TEAM II
		32 7561 SCOOTER RACING MHR
		32 7562 SCOOTER RACING MHR
		32 9027 SCOOTER RACING MHR
		32 9834 SCOOTER RACING MHR
		3213328 SCOOTER RACING MHR BIG BORE
		3213751 SCOOTER RACING MHR BIG BORE
		32 8866 SCOOTER RACING MHR-FFM
		3212115 SCOOTER RACING MHR TEAM

1411745B	for silencers Ø 70	3211737
		3212621
		3212718
		3215230 GP MHR REPLICA
		3212665 GP MHR REPLICA homologated
		3212666 GP MHR REPLICA homologated
		3212667 GP MHR REPLICA homologated
		3212669 GP MHR REPLICA homologated
		3212793 GP MHR REPLICA homologated
		3213278 GP MHR REPLICA homologated
		3213488 SUPERMOTO MHR REP. homologated
		3213491 SUPERMOTO MHR REP. homologated
		3212668 SUPERMOTO MHR REP. homologated
		3212670 SUPERMOTO MHR REP. homologated
		3212671 SUPERMOTO MHR REP. homologated

MALOSSI

MULTIVAR

€ 58,71
New

51 7075 – HOMOLOGATED

2011

Dekra Certification GmbH certifies that Malossi produces its complete variators and CVT-kits efficiently applying a quality management system, as required by the German and International road circulation law (KBA).

2014

Multivar 51 7075 is covered by homologation (Teilegutachten) according to §19 (3) of StVZO (German rulebook for vehicles on the road).

In order to be put on the market, tuning parts in Germany must be first homologated according to the rulebook for vehicles on the road StVZO. Our Multivar variator has successfully overcome the severe tests required by the German regulation in order to obtain the homologation (Teilegutachten).

Tests have been performed directly at Dekra labs in Germany, where the excellent structural and functional features of the Malossi product have been confirmed once again.

Available on website - multivar.malossi.com - the specific assembly instruction

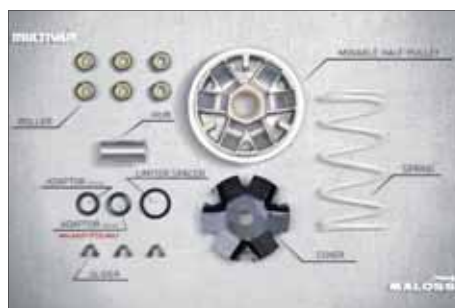



(*) THE LACK OF HOMOLOGATION
DOES NOT NECESSARILY LIMIT ITS USE.

51 7075 MULTIVAR for SCOOTER 50 2T		Homologation Code
APRILIA	AMICO - AREA 51 LC	(*)
	GULLIVER / GULLIVER LC	(*)
	RALLY / RALLY LC (MINARELLI)	(*)
	SCARABEO	e11*92/61*0079*..
	SONIC	e11*92/61*0078*..
	SONIC LC	(*)
	SR - SR NETSCAPER LC (MINARELLI)	(*)
	SR RACING LC (MINARELLI)	(*)
	SR REPLICA LC	e11*2002/24*0126*..
	SR STEALTH LC (MINARELLI) - SR WWW	(*)
ATALA	CAROSELLO	(*)
BENELLI	491 GT (MINARELLI) - 491 SPORT LC (MINARELLI)	(*)
	K2 / K2 LC	(*)
	NAKED - PEPE	(*)
BETA	ARK / ARK LC	(*)
	CHRONO - EIKON LC - QUADRA - TEMPO	(*)
BSV	AX 50 - GZ 50	(*)
FANTIC	BIG WHEEL	(*)
GARELLI	GSP LC euro 2 (1PE40MB) - SR	(*)
ITALJET	DRAGSTER LC - PISTA 2 - SCOOP - YANKEE	(*)
MALAGUTI	CENTRO - CIAK	(*)
	F10	e3*92/61*0038*..
	F12-PHANTOM / F12-PHANTOM LC	(*)
	F12 DIGIT KAT-PHANTOM LC	e3*92/61*0071*..
	F12 DIGIT KAT-PHANTOM LC euro 2	(*)
	F12 R LC euro 2	e3*92/61*0026*..
	F15 FIREFOX LC - YESTERDAY	(*)
MBK	BOOSTER euro 0-1-2 / BOOSTER NG euro 0-1-2	(*)
	BOOSTER NAKED euro 2 (A137E)	(*)
	BOOSTER ROCKET euro 0-1-2	(*)
	BOOSTER SPIRIT euro 0-1	e13*92/61*0024*..
	EVOLIS - FIZZ - FLIPPER - FORTE - HOT CHAMP	(*)
	MACH G / MACH G LC	(*)
	NITRO LC	e13*92/61*0036*..
	OVETTO - SORRISO 1996-> - STUNT euro 0-1-2 - TARGET	(*)
MOTRON	SYNCRO 50 - THUNDER'S 50	(*)
YAMAHA	AEROX LC euro 0-1	e13*92/61*0036*..
	AEROX LC euro 2	e13*2002/24*0592*..
	AXIS - BREEZE - BW'S euro 0-1-2 - BW'S NG euro 0-1-2	(*)
	BW'S Original/Naked euro 2 2010 (A137E)	(*)
	CRZ - JOG - JOG ER - JOG R - JOGRR LC euro 2 - JOG Z	(*)
	NEO'S - SLIDER - SPY - VINO - WHY - ZEST - ZUMA	(*)

NOTE: in order to download
the complete homologation certificate
please visit our website
www.malossi.com.





for VARIATOR SCOOTER 50 > 110

Springs for Multivar and original variator

Silicon-steel springs with high carbon content, heat-treated, dynamically balanced, kiln painted, designed and calculated for each specific application.

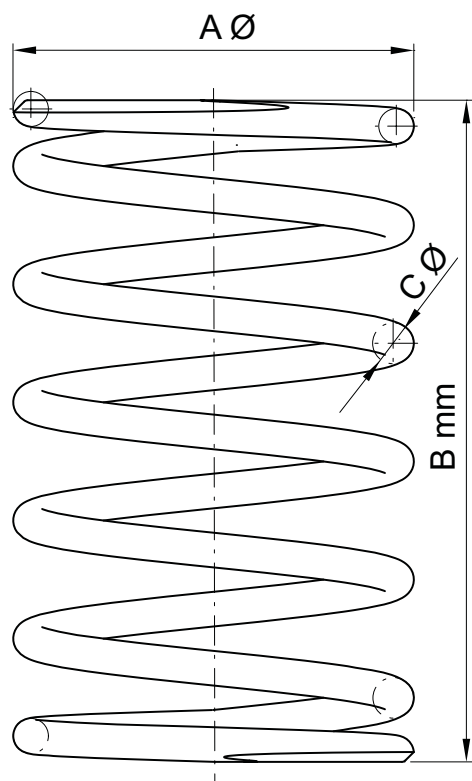

CODE	€	SPRING SIZES			(K) = spring stiffness
		A Ø	B mm	C Ø	
29 7009.YO	6,50	45	77	3,9	8,4k
29 6955.RO	8,00	45	77	4	9,4k
2911388.YO	10,71	52,6	81	4,3	7,6k
29 7047.WO	5,91	53,1	110	3,6	3,5k
29 7045.YO	5,91	53,5	115	3,7	3,8k
29 7046.RO	5,91	53,7	110	3,9	4,7k
2912658.WO	6,50	57,5	105,5	4	4,2k
2911266.YO	10,71	57,5	120	4,5	5,5k
29 7042.YO	5,91	57,8	90	4,1	6,1k
29 7043.RO	5,91	57,8	90	4,2	6,8k
29 8323.GO	9,66	57,8	91	3,9	4,9k
29 8324.VO	9,66	57,8	91	4	5,5k
29 8325.AO	9,66	57,8	91	4,1	6,1k
2916111.BO	9,00	57,8	103	4	5,5k
29 8360.WO	6,50	57,8	118	4	3,3k
29 7077.YO	6,50	61,6	138	3,9	2,4k
29 7087.RO	7,00	61,8	138	4	2,6k

ATTENTION:

a complete description of the spring desired is needed when ordering.

Es. 29 7632.AO Blue



.WO White

.YO Yellow







.RO Red

.GO Green

.VO Violet

.AO Blue

.BO Black

SCOOTER 50 > 110		(*)		(*)		(*)		(*)		(*)		(*)		(*)
APRILIA														
AMICO 50 2T	29 7047.WO	30	29 7045.YO	35	29 7046.RO	40	---	---	---	---	---	---	---	---
AREA 51 50 2T LC	29 7047.WO	30	29 7045.YO	35	29 7046.RO	40	---	---	---	---	---	---	---	---
GULLIVER 50 2T / 50 2T LC	29 7047.WO	30	29 7045.YO	35	29 7046.RO	40	---	---	---	---	---	---	---	---
HABANA 50 2T	29 7047.WO	30	29 7045.YO	35	29 7046.RO	40	---	---	---	---	---	---	---	---
MOJITO 50 2T	29 7047.WO	30	29 7045.YO	35	29 7046.RO	40	---	---	---	---	---	---	---	---
MOJITO CUSTOM 50 2T	29 8360.WO	30	---	---	---	---	29 8323.GO	60	29 8324.VO	82	29 8325.AO	106	2916111.BO	114
RALLY 50 2T / 50 2T LC (MINARELLI)	29 7047.WO	30	29 7045.YO	35	29 7046.RO	40	---	---	---	---	---	---	---	---
SCARABEO 50 2T (MINARELLI)	29 7047.WO	30	29 7045.YO	35	29 7046.RO	40	---	---	---	---	---	---	---	---
SCARABEO STREET 50 2T (PIAGGIO)	29 8360.WO	30	---	---	---	---	29 8323.GO	60	29 8324.VO	82	29 8325.AO	106	2916111.BO	114
SCARABEO 50 4T (PIAGGIO C373M)	29 8360.WO	30	---	---	---	---	29 8323.GO	60	29 8324.VO	82	29 8325.AO	106	2916111.BO	114
SCARABEO 4V 50 4T euro 2	29 8360.WO	30	---	---	---	---	29 8323.GO	60	29 8324.VO	82	29 8325.AO	106	2916111.BO	114
SCARABEO 100 2T	---	---	2911388.YO	5	---	---	---	---	---	---	---	---	---	---
SONIC 50 2T / 50 2T LC	29 7047.WO	30	29 7045.YO	35	29 7046.RO	40	---	---	---	---	---	---	---	---
SPORTCITY ONE STREET 50 2T euro 2	29 8360.WO	30	---	---	---	---	29 8323.GO	60	29 8324.VO	82	29 8325.AO	106	2916111.BO	114
SPORTCITY ONE 50 4T (PIAGGIO C377M)	29 8360.WO	30	---	---	---	---	29 8323.GO	60	29 8324.VO	82	29 8325.AO	106	2916111.BO	114
SR 50 2T	29 7047.WO	30	29 7045.YO	35	29 7046.RO	40	---	---	---	---	---	---	---	---
SR (carb.) 50 2T LC 2004-> (PIAGGIO)	29 8360.WO	30	---	---	---	---	29 8323.GO	60	29 8324.VO	82	29 8325.AO	106	2916111.BO	114
SR R (carb.) 50 2T LC (PIAGGIO)	29 8360.WO	30	---	---	---	---	29 8323.GO	60	29 8324.VO	82	29 8325.AO	106	2916111.BO	114
SR DITECH 50 2T LC (APRILIA)	29 7047.WO	30	29 7045.YO	35	29 7046.RO	40	---	---	---	---	---	---	---	---
SR MOTARD 50 2T euro 2	29 8360.WO	30	---	---	---	---	29 8323.GO	60	29 8324.VO	82	29 8325.AO	106	2916111.BO	114
SR NETSCAPER 50 2T LC (MINARELLI)	29 7047.WO	30	29 7045.YO	35	29 7046.RO	40	---	---	---	---	---	---	---	---
SR RACING 50 2T LC (MINARELLI)	29 7047.WO	30	29 7045.YO	35	29 7046.RO	40	---	---	---	---	---	---	---	---
SR REPLICA 50 2T LC <-1999	29 7047.WO	30	29 7045.YO	35	29 7046.RO	40	---	---	---	---	---	---	---	---
SR REPLICA 50 2T LC 2000-> (APRILIA)	29 7047.WO	30	29 7045.YO	35	29 7046.RO	40	---	---	---	---	---	---	---	---
SR STEALTH 50 2T LC (MINARELLI)	29 7047.WO	30	29 7045.YO	35	29 7046.RO	40	---	---	---	---	---	---	---	---
SR WWW 50 2T	29 7047.WO	30	29 7045.YO	35	29 7046.RO	40	---	---	---	---	---	---	---	---
ATALA														
CAROSSELLO 50 2T	29 7047.WO	30	29 7045.YO	35	29 7046.RO	40	---	---	---	---	---	---	---	---
HACKER 50 2T / 50 2T LC	29 7047.WO	30	29 7045.YO	35	29 7046.RO	40	---	---	---	---	---	---	---	---
BAOTIAN														
ECO BIKE 50 4T (139 QMB)	2912658.WO	5	29 7042.YO	30	29 7043.RO	35	---	---	---	---	---	---	---	---
REBEL - ROCKY - TANCO 9/12 50 4T	2912658.WO	5	29 7042.YO	30	29 7043.RO	35	---	---	---	---	---	---	---	---
BENELLI														
491 GT 50 2T (MINARELLI)	29 7047.WO	30	29 7045.YO	35	29 7046.RO	40	---	---	---	---	---	---	---	---
491 SPORT 50 2T LC (MINARELLI)	29 7047.WO	30	29 7045.YO	35	29 7046.RO	40	---	---	---	---	---	---	---	---
K2 50 2T / 50 2T LC	29 7047.WO	30	29 7045.YO	35	29 7046.RO	40	---	---	---	---	---	---	---	---
K2 100 2T	---	---	2911388.YO	5	---	---	---	---	---	---	---	---	---	---
NAKED 50 2T	29 7047.WO	30	29 7045.YO	35	29 7046.RO	40	---	---	---	---	---	---	---	---
PEPE 50 2T	29 7047.WO	30	29 7045.YO	35	29 7046.RO	40	---	---	---	---	---	---	---	---
PEPE LX 50 2T euro 2 (QJ1E40QMB-4)	29 7047.WO	30	29 7045.YO	35	29 7046.RO	40	---	---	---	---	---	---	---	---
QuattronoveX 50 2T euro 2	29 7047.WO	30	29 7045.YO	35	29 7046.RO	40	---	---	---	---	---	---	---	---
BETA														
ARK 50 2T / 50 2T LC	29 7047.WO	30	29 7045.YO	35	29 7046.RO	40	---	---	---	---	---	---	---	---
CHRONO 50 2T	29 7047.WO	30	29 7045.YO	35	29 7046.RO	40	---	---	---	---	---	---	---	---
EIKON 50 2T LC	29 7047.WO	30	29 7045.YO	35	29 7046.RO	40	---	---	---	---	---	---	---	---
QUADRA 50 2T	29 7047.WO	30	29 7045.YO	35	29 7046.RO	40	---	---	---	---	---	---	---	---
TEMPO 50 2T	29 7047.WO	30	29 7045.YO	35	29 7046.RO	40	---	---	---	---	---	---	---	---
BSV														
AX 50	29 7047.WO	30	29 7045.YO	35	29 7046.RO	40	---	---	---	---	---	---	---	---
DIO GP 50	---	---	29 7042.YO	30	29 7043.RO	35	---	---	---	---	---	---	---	---
DIO SP 50	---	---	29 7042.YO	30	29 7043.RO	35	---	---	---	---	---	---	---	---
DIO SR 50	---	---	29 7042.YO	30	29 7043.RO	35	---	---	---	---	---	---	---	---
DIO ZX 50 2T	2912658.WO	5	---	---	29 7043.RO	35	---	---	---	---	---	---	---	---
GZ 50	29 7047.WO	30	29 7045.YO	35	29 7046.RO	40	---	---	---	---	---	---	---	---
CAGIVA														
CITY 50 2T	---	---	29 7042.YO	30	29 7043.RO	35	---	---	---	---	---	---	---	---
PROGRESS 50 2T	29 7047.WO	30	29 7045.YO	35	29 7046.RO	40	---	---	---	---	---	---	---	---
CPI														
ARAGON GP 50 2T	29 7047.WO	30	29 7045.YO	35	29 7046.RO	40	---	---	---	---	---	---	---	---
HUSSAR 50 2T	29 7047.WO	30	29 7045.YO	35	29 7046.RO	40	---	---	---	---	---	---	---	---
OLIVER 50 2T	29 7047.WO	30	29 7045.YO	35	29 7046.RO	40	---	---	---	---	---	---	---	---
POPCORN 50 2T	29 7047.WO	30	29 7045.YO	35	29 7046.RO	40	---	---	---	---	---	---	---	---



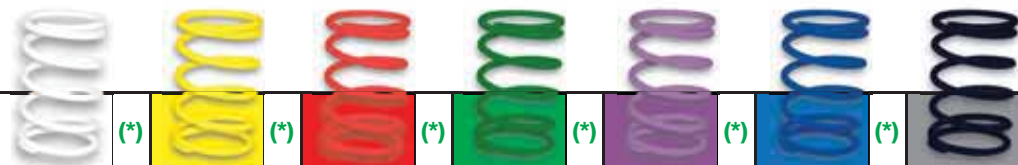



(*) % Increase in rigidy compared to the original



SCOOTER 50 > 110		(*)		(*)		(*)		(*)		(*)		(*)		
DERBI														
ATLANTIS 50 2T <-2002	29 7047.WO	30	29 7045.YO	35	29 7046.RO	40	---	---	---	---	---	---		
ATLANTIS - BULLET 50 2T 2003->	29 8360.WO	30	---	---	---	---	29 8323.GO	60	29 8324.VO	82	29 8325.AO	106	2916111.BO	114
ATLANTIS 50 2T LC	29 7047.WO	30	29 7045.YO	35	29 7046.RO	40	---	---	---	---	---	---	---	
GP1 50 2T LC	29 8360.WO	30	---	---	---	---	29 8323.GO	60	29 8324.VO	82	29 8325.AO	106	2916111.BO	114
GP1 OPEN 50 2T LC	29 8360.WO	30	---	---	---	---	29 8323.GO	60	29 8324.VO	82	29 8325.AO	106	2916111.BO	114
GP1 REVOLUTION 50 2T LC	29 8360.WO	30	---	---	---	---	29 8323.GO	60	29 8324.VO	82	29 8325.AO	106	2916111.BO	114
HUNTER 50 2T	29 7047.WO	30	29 7045.YO	35	29 7046.RO	40	---	---	---	---	---	---	---	
PADDOCK 50 2T / 50 2T LC	29 7047.WO	30	29 7045.YO	35	29 7046.RO	40	---	---	---	---	---	---	---	
PREDATOR 50 2T / 50 2T LC	29 7047.WO	30	29 7045.YO	35	29 7046.RO	40	---	---	---	---	---	---	---	
EXPLORER														
CRACKER 50 2T 2003-> (GE 1E 400 MB)	29 7047.WO	30	29 7045.YO	35	29 7046.RO	40	---	---	---	---	---	---	---	
FANTIC														
BIG WHEEL 50 2T	29 7047.WO	30	29 7045.YO	35	29 7046.RO	40	---	---	---	---	---	---	---	
GARELLI														
FLEXI' 50 4T euro 2 (1P139 QMB)	2912658.WO	5	29 7042.YO	30	29 7043.RO	35	---	---	---	---	---	---	---	
GSP 50 2T LC euro 2 (1PE40MB)	29 7047.WO	30	29 7045.YO	35	29 7046.RO	40	---	---	---	---	---	---	---	
PONY 50 2T	29 7047.WO	30	29 7045.YO	35	29 7046.RO	40	---	---	---	---	---	---	---	
SR 50 2T	29 7047.WO	30	29 7045.YO	35	29 7046.RO	40	---	---	---	---	---	---	---	
TIESSE 50R 50 2T euro 2 (1E40QMB)	29 7047.WO	30	29 7045.YO	35	29 7046.RO	40	---	---	---	---	---	---	---	
TIESSE FOUR 50 4T euro 2 (1P39QMB)	2912658.WO	5	29 7042.YO	30	29 7043.RO	35	---	---	---	---	---	---	---	
VIP 50 4T (139 QMA)	2912658.WO	5	29 7042.YO	30	29 7043.RO	35	---	---	---	---	---	---	---	
GILERA														
DNA 50 2T LC	29 8360.WO	30	---	---	---	---	29 8323.GO	60	29 8324.VO	82	29 8325.AO	106	2916111.BO	114
EASY MOVING 50 2T	29 8360.WO	30	---	---	---	---	29 8323.GO	60	29 8324.VO	82	29 8325.AO	106	2916111.BO	114
ICE 50 2T	29 8360.WO	30	---	---	---	---	29 8323.GO	60	29 8324.VO	82	29 8325.AO	106	2916111.BO	114
RUNNER 50 2T LC	29 8360.WO	30	---	---	---	---	29 8323.GO	60	29 8324.VO	82	29 8325.AO	106	2916111.BO	114
RUNNER PureJet 50 2T LC	29 8360.WO	30	---	---	---	---	29 8323.GO	60	29 8324.VO	82	29 8325.AO	106	2916111.BO	114
RUNNER SP 50 2T LC	29 8360.WO	30	---	---	---	---	29 8323.GO	60	29 8324.VO	82	29 8325.AO	106	2916111.BO	114
STALKER 50 2T	29 8360.WO	30	---	---	---	---	29 8323.GO	60	29 8324.VO	82	29 8325.AO	106	2916111.BO	114
STORM 50 2T	29 8360.WO	30	---	---	---	---	29 8323.GO	60	29 8324.VO	82	29 8325.AO	106	2916111.BO	114
TYPHOON 50 2T	29 8360.WO	30	---	---	---	---	29 8323.GO	60	29 8324.VO	82	29 8325.AO	106	2916111.BO	114
TYPHOON X 50 2T	29 8360.WO	30	---	---	---	---	29 8323.GO	60	29 8324.VO	82	29 8325.AO	106	2916111.BO	114
HONDA														
BALI 50 2T	---	---	29 7042.YO	30	29 7043.RO	35	---	---	---	---	---	---	---	
DIO G 50 2T	---	---	29 7042.YO	30	29 7043.RO	35	---	---	---	---	---	---	---	
DIO SP 50 2T	---	---	29 7042.YO	30	29 7043.RO	35	---	---	---	---	---	---	---	
DIO SR 50 2T	---	---	29 7042.YO	30	29 7043.RO	35	---	---	---	---	---	---	---	
DIO ZX 50 2T	2912658.WO	5	---	---	29 7043.RO	35	---	---	---	---	---	---	---	
LEAD 50 2T	---	---	29 7042.YO	30	29 7043.RO	35	---	---	---	---	---	---	---	
NSC50R 50 ie 4T euro 2 (AF72E)	2912658.WO	5	29 7042.YO	30	29 7043.RO	35	---	---	---	---	---	---	---	
SFX 50 2T	---	---	29 7042.YO	30	29 7043.RO	35	---	---	---	---	---	---	---	
SGX SKY 50 2T	---	---	29 7042.YO	30	29 7043.RO	35	---	---	---	---	---	---	---	
SH 50 2T	---	---	29 7042.YO	30	29 7043.RO	35	---	---	---	---	---	---	---	
SHADOW 50 2T	---	---	29 7042.YO	30	29 7043.RO	35	---	---	---	---	---	---	---	
SXR 50 2T	---	---	29 7042.YO	30	29 7043.RO	35	---	---	---	---	---	---	---	
VISION 50 2T	---	---	29 7042.YO	30	29 7043.RO	35	---	---	---	---	---	---	---	
VISION MET IN 50 2T	---	---	29 7042.YO	30	29 7043.RO	35	---	---	---	---	---	---	---	
VISION 50 ie 4T (AF72E)	2912658.WO	5	29 7042.YO	30	29 7043.RO	35	---	---	---	---	---	---	---	
X8R X - X8R S 50 2T	---	---	29 7042.YO	30	29 7043.RO	35	---	---	---	---	---	---	---	
HSC														
SC 01 50	---	---	29 7042.YO	30	29 7043.RO	35	---	---	---	---	---	---	---	
SC 01 L 50	2912658.WO	5	---	---	29 7043.RO	35	---	---	---	---	---	---	---	
HUPPER														
MONTECARLO 30 50 2T (1E40QMB)	29 7047.WO	30	29 7045.YO	35	29 7046.RO	40	---	---	---	---	---	---	---	
MONTECARLO 30 50 4T (139QMB)	2912658.WO	5	29 7042.YO	30	29 7043.RO	35	---	---	---	---	---	---	---	
ITALJET														
BAZOOKA 50 2T	29 7047.WO	30	29 7045.YO	35	29 7046.RO	40	---	---	---	---	---	---	---	
DRAGSTER 50 2T LC	29 7047.WO	30	29 7045.YO	35	29 7046.RO	40	---	---	---	---	---	---	---	
FORMULA 50 2T / 50 2T LC (F.MORINI)	29 7047.WO	30	29 7045.YO	35	29 7046.RO	40	---	---	---	---	---	---	---	
JET SET 50 2T	29 8360.WO	30	---	---	---	---	29 8323.GO	60	29 8324.VO	82	29 8325.AO	106	2916111.BO	114
MILLENNIUM 100 2T	---	---	2911388.YO	5	---	---	---	---	---	---	---	---	---	
PISTA 50 2T	29 7047.WO	30	29 7045.YO	35	29 7046.RO	40	---	---	---	---	---	---	---	

Products to be used exclusively for racing in places specially designed for such activity according to the regulations of the competent sporting authorities. We accept no liability resulting from improper use.

(*) % Increase in rigidity compared to the original

SCOOTER 50 > 110		(*)		(*)		(*)		(*)		(*)		(*)		(*)
PISTA 2 50 2T	29 7047.WO	30	29 7045.YO	35	29 7046.RO	40	---	---	---	---	---	---	---	---
REPORTER 50	29 7047.WO	30	29 7045.YO	35	29 7046.RO	40	---	---	---	---	---	---	---	---
SCOOP 50 2T	29 7047.WO	30	29 7045.YO	35	29 7046.RO	40	---	---	---	---	---	---	---	---
TORPEDO 50 2T	29 7047.WO	30	29 7045.YO	35	29 7046.RO	40	---	---	---	---	---	---	---	---
TORPEDO 50 4T	29 8360.WO	30	---	---	---	29 8323.GO	60	29 8324.VO	82	29 8325.AO	106	2916111.BO	114	---
VELOCIFERO 50 2T	29 7047.WO	30	29 7045.YO	35	29 7046.RO	40	---	---	---	---	---	---	---	---
YANKEE 50 2T	29 7047.WO	30	29 7045.YO	35	29 7046.RO	40	---	---	---	---	---	---	---	---
KEEWAY														
F-ACT 50 2T	29 7047.WO	30	29 7045.YO	35	29 7046.RO	40	---	---	---	---	---	---	---	---
GOCCIA 50 2T (KW1E40QMB-4)	29 7047.WO	30	29 7045.YO	35	29 7046.RO	40	---	---	---	---	---	---	---	---
HURRICANE 50 2T euro 2 (KW1E40QMB)	29 7047.WO	30	29 7045.YO	35	29 7046.RO	40	---	---	---	---	---	---	---	---
MATRIX 50 2T (KW1E40QMB-4)	29 7047.WO	30	29 7045.YO	35	29 7046.RO	40	---	---	---	---	---	---	---	---
PIXEL 50 2T euro 2 (KW1E40QMB)	29 7047.WO	30	29 7045.YO	35	29 7046.RO	40	---	---	---	---	---	---	---	---
RY8 50 2T (KW1E40QMB-4)	29 7047.WO	30	29 7045.YO	35	29 7046.RO	40	---	---	---	---	---	---	---	---
KYMCO														
AGILITY R16 50 2T euro 2 (KF10B)	29 8360.WO	30	---	---	---	29 8323.GO	60	29 8324.VO	82	29 8325.AO	106	2916111.BO	114	---
CX 50 2T	2912658.WO	5	---	---	29 7043.RO	35	---	---	---	---	---	---	---	---
DINK 50 2T	29 8360.WO	30	---	---	---	29 8323.GO	60	29 8324.VO	82	29 8325.AO	106	2916111.BO	114	---
DJ X 50 2T	---	---	29 7042.YO	30	29 7043.RO	35	---	---	---	---	---	---	---	---
DJ Y 50 2T	2912658.WO	5	---	---	29 7043.RO	35	---	---	---	---	---	---	---	---
HEROISM 50 2T	2912658.WO	5	---	---	29 7043.RO	35	---	---	---	---	---	---	---	---
K 12 50 2T	29 8360.WO	30	---	---	---	29 8323.GO	60	29 8324.VO	82	29 8325.AO	106	2916111.BO	114	---
PEOPLE 50 2T	29 8360.WO	30	---	---	---	29 8323.GO	60	29 8324.VO	82	29 8325.AO	106	2916111.BO	114	---
SNIPER 50 2T	2912658.WO	5	---	---	29 7043.RO	35	---	---	---	---	---	---	---	---
SUPER 9 50 2T LC	29 8360.WO	30	---	---	---	29 8323.GO	60	29 8324.VO	82	29 8325.AO	106	2916111.BO	114	---
TOP BOY - COBRA 50 2T	29 8360.WO	30	---	---	---	29 8323.GO	60	29 8324.VO	82	29 8325.AO	106	2916111.BO	114	---
LEM														
FLASH 50	29 7047.WO	30	29 7045.YO	35	29 7046.RO	40	---	---	---	---	---	---	---	---
GHIBLI 50	29 7047.WO	30	29 7045.YO	35	29 7046.RO	40	---	---	---	---	---	---	---	---
TORNADO 50	29 7047.WO	30	29 7045.YO	35	29 7046.RO	40	---	---	---	---	---	---	---	---
MALAGUTI														
CENTRO 50 2T	29 7047.WO	30	29 7045.YO	35	29 7046.RO	40	---	---	---	---	---	---	---	---
CENTRO 50 4T euro 2 (C432M)	29 8360.WO	30	---	---	---	29 8323.GO	60	29 8324.VO	82	29 8325.AO	106	2916111.BO	114	---
CIAK 50 2T	29 7047.WO	30	29 7045.YO	35	29 7046.RO	40	---	---	---	---	---	---	---	---
CIAK MASTER 50 4T euro 2	29 8360.WO	30	---	---	---	29 8323.GO	60	29 8324.VO	82	29 8325.AO	106	2916111.BO	114	---
CROSSER CR1 50 2T	29 7047.WO	30	29 7045.YO	35	29 7046.RO	40	---	---	---	---	---	---	---	---
DVD 50 4T (139 QMB)	2912658.WO	5	29 7042.YO	30	29 7043.RO	35	---	---	---	---	---	---	---	---
F10 50 2T	29 7047.WO	30	29 7045.YO	35	29 7046.RO	40	---	---	---	---	---	---	---	---
F10 WAP 50 2T euro 2 (QJ*CMA03C*)	29 7047.WO	30	29 7045.YO	35	29 7046.RO	40	---	---	---	---	---	---	---	---
F12-PHANTOM 50 2T / 50 2T LC	29 7047.WO	30	29 7045.YO	35	29 7046.RO	40	---	---	---	---	---	---	---	---
F12 DIGIT KAT-PHANTOM 50 2T LC / LC euro 2	29 7047.WO	30	29 7045.YO	35	29 7046.RO	40	---	---	---	---	---	---	---	---
F12 R ARIA 50 2T euro 2 (QJ*CMA02C*)	29 7047.WO	30	29 7045.YO	35	29 7046.RO	40	---	---	---	---	---	---	---	---
F12 R LC 50 2T LC euro 2	29 7047.WO	30	29 7045.YO	35	29 7046.RO	40	---	---	---	---	---	---	---	---
F15 FIREFOX 50 2T LC	29 7047.WO	30	29 7045.YO	35	29 7046.RO	40	---	---	---	---	---	---	---	---
YESTERDAY 50 2T	29 7047.WO	30	29 7045.YO	35	29 7046.RO	40	---	---	---	---	---	---	---	---
MBK														
ACTIVE 50	29 7047.WO	30	29 7045.YO	35	29 7046.RO	40	---	---	---	---	---	---	---	---
BOOSTER 50 2T euro 0-1	29 7047.WO	30	29 7045.YO	35	29 7046.RO	40	---	---	---	---	---	---	---	---
BOOSTER 50 2T euro 2 (A137E)	29 8360.WO	30	---	---	---	29 8323.GO	60	29 8324.VO	82	29 8325.AO	106	2916111.BO	114	---
BOOSTER 100 2T	---	---	2911388.YO	5	---	---	---	---	---	---	---	---	---	---
BOOSTER NAKED 50 2T euro 2 (A137E)	29 8360.WO	30	---	---	---	29 8323.GO	60	29 8324.VO	82	29 8325.AO	106	2916111.BO	114	---
BOOSTER NG 50 2T euro 0-1	29 7047.WO	30	29 7045.YO	35	29 7046.RO	40	---	---	---	---	---	---	---	---
BOOSTER NG 50 2T euro 2 (A137E)	29 8360.WO	30	---	---	---	29 8323.GO	60	29 8324.VO	82	29 8325.AO	106	2916111.BO	114	---
BOOSTER ROCKET 50 2T euro 0-1	29 7047.WO	30	29 7045.YO	35	29 7046.RO	40	---	---	---	---	---	---	---	---
BOOSTER ROCKET 50 2T euro 2 (A137E)	29 8360.WO	30	---	---	---	29 8323.GO	60	29 8324.VO	82	29 8325.AO	106	2916111.BO	114	---
BOOSTER SPIRIT 50 2T euro 0-1	29 7047.WO	30	29 7045.YO	35	29 7046.RO	40	---	---	---	---	---	---	---	---
EVOLIS 50 2T	29 7047.WO	30	29 7045.YO	35	29 7046.RO	40	---	---	---	---	---	---	---	---
FIZZ 50 2T	29 7047.WO	30	29 7045.YO	35	29 7046.RO	40	---	---	---	---	---	---	---	---
FLIPPER 50 2T	29 7047.WO	30	29 7045.YO	35	29 7046.RO	40	---	---	---	---	---	---	---	---
FORTE 50 2T	29 7047.WO	30	29 7045.YO	35	29 7046.RO	40	---	---	---	---	---	---	---	---
HOT CHAMP 50 2T	29 7047.WO	30	29 7045.YO	35	29 7046.RO	40	---	---	---	---	---	---	---	---
MACH G 50 2T / 50 2T LC	29 7047.WO	30	29 7045.YO	35	29 7046.RO	40	---	---	---	---	---	---	---	---
NITRO 50 2T LC	29 7047.WO	30	29 7045.YO	35	29 7046.RO	40	---	---	---	---	---	---	---	---



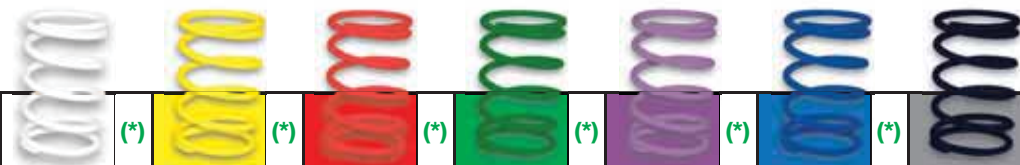



(*) % Increase in rigidy compared to the original



SCOOTER 50 > 110		(*)		(*)		(*)		(*)		(*)		(*)		
NITRO 100 2T	---		2911388.YO	5	---		---		---		---			
OVETTO 50 2T	29 7047.WO	30	29 7045.YO	35	29 7046.RO	40	---		---		---			
OVETTO 100 2T	---		2911388.YO	5	---		---		---		---			
SORRISO 50 2T	29 7047.WO	30	29 7045.YO	35	29 7046.RO	40	---		---		---			
STUNT 50 2T euro 0-1	29 7047.WO	30	29 7045.YO	35	29 7046.RO	40	---		---		---			
STUNT 50 2T euro 2	29 8360.WO	30	---		---		29 8323.GO	60	29 8324.VO	82	29 8325.AO	106	2916111.BO	114
TARGET 50 2T	29 7047.WO	30	29 7045.YO	35	29 7046.RO	40	---		---		---		---	
MOTRON														
SYNCR0 50	29 7047.WO	30	29 7045.YO	35	29 7046.RO	40	---		---		---		---	
THUNDER'S 50	29 7047.WO	30	29 7045.YO	35	29 7046.RO	40	---		---		---		---	
OVER														
B3 50 4T LC (LJ1P38MB)	2912658.WO	5	29 7042.YO	30	29 7043.RO	35	---		---		---		---	
THOR 50 2T LC 2013-> (LJ1PE40MB)	29 7047.WO	30	29 7045.YO	35	29 7046.RO	40	---		---		---		---	
PEUGEOT														
BUXY 50 2T	2912658.WO	5	---		---		29 8323.GO	60	29 8324.VO	82	29 8325.AO	106	2916111.BO	114
BUXY RS 50 2T	2912658.WO	5	---		---		29 8323.GO	60	29 8324.VO	82	29 8325.AO	106	2916111.BO	114
ELYSEO 50 2T	2912658.WO	5	---		---		29 8323.GO	60	29 8324.VO	82	29 8325.AO	106	2916111.BO	114
JET FORCE C-TECH 50 2T LC	2912658.WO	5	---		---		29 8323.GO	60	29 8324.VO	82	29 8325.AO	106	2916111.BO	114
JET FORCE TSDI 50 2T LC (HL 1)	2912658.WO	5	---		---		29 8323.GO	60	29 8324.VO	82	29 8325.AO	106	2916111.BO	114
LOOXOR 50 2T	2912658.WO	5	---		---		29 8323.GO	60	29 8324.VO	82	29 8325.AO	106	2916111.BO	114
LOOXOR TSDI 50 2T	2912658.WO	5	---		---		29 8323.GO	60	29 8324.VO	82	29 8325.AO	106	2916111.BO	114
LUDIX 50 2T	2912658.WO	5	---		---		29 8323.GO	60	29 8324.VO	82	29 8325.AO	106	2916111.BO	114
LUDIX BLASTER 50 2T LC (HL 2)	2912658.WO	5	---		---		29 8323.GO	60	29 8324.VO	82	29 8325.AO	106	2916111.BO	114
METAL-X 50 2T	2912658.WO	5	---		---		29 8323.GO	60	29 8324.VO	82	29 8325.AO	106	2916111.BO	114
RAPIDO 50 2T	---		29 7042.YO	30	29 7043.RO	35	---		---		---		---	
SC L METROPOLIS 50 2T	---		29 7042.YO	30	29 7043.RO	35	---		---		---		---	
SPEEDAKE 50 2T	2912658.WO	5	---		---		29 8323.GO	60	29 8324.VO	82	29 8325.AO	106	2916111.BO	114
SPEEDFIGHT 50 2T / 50 2T LC	2912658.WO	5	---		---		29 8323.GO	60	29 8324.VO	82	29 8325.AO	106	2916111.BO	114
SPEEDFIGHT 2 50 2T LC 2004->	2912658.WO	5	---		---		29 8323.GO	60	29 8324.VO	82	29 8325.AO	106	2916111.BO	114
SPEEDFIGHT 3 50 2T / 50 2T LC	2912658.WO	5	---		---		29 8323.GO	60	29 8324.VO	82	29 8325.AO	106	2916111.BO	114
SPEEDFIGHT 3 50 4T (XS1P37QMA-2)	2912658.WO	5	---		---		29 8323.GO	60	29 8324.VO	82	29 8325.AO	106	2916111.BO	114
SQUAB 50 2T	2912658.WO	5	---		---		29 8323.GO	60	29 8324.VO	82	29 8325.AO	106	2916111.BO	114
ST 50 2T	---		29 7042.YO	30	29 7043.RO	35	---		---		---		---	
SV GEO 50 2T	---		29 7042.YO	30	29 7043.RO	35	---		---		---		---	
TREKKER 50 2T	2912658.WO	5	---		---		29 8323.GO	60	29 8324.VO	82	29 8325.AO	106	2916111.BO	114
TWEET 50 4T euro 2	2912658.WO	5	---		---		29 8323.GO	60	29 8324.VO	82	29 8325.AO	106	2916111.BO	114
TWEET² RS 50 4T euro 2	2912658.WO	5	---		---		29 8323.GO	60	29 8324.VO	82	29 8325.AO	106	2916111.BO	114
V-CLIC 50 4T	2912658.WO	5	29 7042.YO	30	29 7043.RO	35	---		---		---		---	
VIVACITY 50 2T	2912658.WO	5	---		---		29 8323.GO	60	29 8324.VO	82	29 8325.AO	106	2916111.BO	114
VIVACITY COMPACT 50 2T (FB2FP)	2912658.WO	5	---		---		29 8323.GO	60	29 8324.VO	82	29 8325.AO	106	2916111.BO	114
X-FIGHT 50 2T / 50 2T LC	2912658.WO	5	---		---		29 8323.GO	60	29 8324.VO	82	29 8325.AO	106	2916111.BO	114
X-FIGHT 2 50 2T LC 2004->	2912658.WO	5	---		---		29 8323.GO	60	29 8324.VO	82	29 8325.AO	106	2916111.BO	114
ZENITH 50 2T	2912658.WO	5	---		---		29 8323.GO	60	29 8324.VO	82	29 8325.AO	106	2916111.BO	114
PGO														
BIG MAX 50	---		29 7042.YO	30	29 7043.RO	35	---		---		---		---	
COMET 50	29 7047.WO	30	29 7045.YO	35	29 7046.RO	40	---		---		---		---	
RATTLER 110 2T	---		2911266.YO	5,5	---		---		---		---		---	
STAR 50	---		29 7042.YO	30	29 7043.RO	35	---		---		---		---	
STAR II 50	29 7047.WO	30	29 7045.YO	35	29 7046.RO	40	---		---		---		---	
PIAGGIO														
DIESIS 50 2T	29 8360.WO	30	---		---		29 8323.GO	60	29 8324.VO	82	29 8325.AO	106	2916111.BO	114
FLY 50 2T - 50 4T	29 8360.WO	30	---		---		29 8323.GO	60	29 8324.VO	82	29 8325.AO	106	2916111.BO	114
FREE 50 2T	29 8360.WO	30	---		---		29 8323.GO	60	29 8324.VO	82	29 8325.AO	106	2916111.BO	114
LIBERTY 50 2T - 50 4T	29 8360.WO	30	---		---		29 8323.GO	60	29 8324.VO	82	29 8325.AO	106	2916111.BO	114
LIBERTY 4V 50 4T euro 2	29 8360.WO	30	---		---		29 8323.GO	60	29 8324.VO	82	29 8325.AO	106	2916111.BO	114
NEW FLY 4V 50 4T euro 2	29 8360.WO	30	---		---		29 8323.GO	60	29 8324.VO	82	29 8325.AO	106	2916111.BO	114
NRG 50 2T LC	29 8360.WO	30	---		---		29 8323.GO	60	29 8324.VO	82	29 8325.AO	106	2916111.BO	114
NRG EXTREME 50 2T / 50 2T LC	29 8360.WO	30	---		---		29 8323.GO	60	29 8324.VO	82	29 8325.AO	106	2916111.BO	114
NRG MC2 50 2T LC	29 8360.WO	30	---		---		29 8323.GO	60	29 8324.VO	82	29 8325.AO	106	2916111.BO	114
NRG MC3 DD 50 2T LC	29 8360.WO	30	---		---		29 8323.GO	60	29 8324.VO	82	29 8325.AO	106	2916111.BO	114
NRG MC3 DT 50 2T	29 8360.WO	30	---		---		29 8323.GO	60	29 8324.VO	82	29 8325.AO	106	2916111.BO	114
NRG Power DD 50 2T LC	29 8360.WO	30	---		---		29 8323.GO	60	29 8324.VO	82	29 8325.AO	106	2916111.BO	114
NRG Power DT 50 2T (C453M)	29 8360.WO	30	---		---		29 8323.GO	60	29 8324.VO	82	29 8325.AO	106	2916111.BO	114

Products to be used exclusively for racing in places specially designed for such activity according to the regulations of the competent sporting authorities. We accept no liability resulting from improper use.

(*) % Increase in rigidity compared to the original

SCOOTER 50 > 110		(*)		(*)		(*)		(*)		(*)		(*)		(*)
NRG Power Purejet 50 2T LC	29 8360.WO	30	---	---	---	---	29 8323.G0	60	29 8324.V0	82	29 8325.A0	106	2916111.B0	114
NTT 50 2T LC	29 8360.WO	30	---	---	---	---	29 8323.G0	60	29 8324.V0	82	29 8325.A0	106	2916111.B0	114
QUARTZ 50 2T LC	29 8360.WO	30	---	---	---	---	29 8323.G0	60	29 8324.V0	82	29 8325.A0	106	2916111.B0	114
SFERA 50 2T	---	---	29 7077.Y0	30	29 7087.R0	35	---	---	---	---	---	---	---	---
SFERA RESTYLING 50 2T	29 8360.WO	30	---	---	---	---	29 8323.G0	60	29 8324.V0	82	29 8325.A0	106	2916111.B0	114
TYPHOON 50 2T 2007->2010	29 8360.WO	30	---	---	---	---	29 8323.G0	60	29 8324.V0	82	29 8325.A0	106	2916111.B0	114
TYPHOON 50 2T euro 2 2011-> (C421M)	29 8360.WO	30	---	---	---	---	29 8323.G0	60	29 8324.V0	82	29 8325.A0	106	2916111.B0	114
ZIP 50 2T <-1999	---	---	29 7077.Y0	30	29 7087.R0	35	---	---	---	---	---	---	---	---
ZIP 50 2T 2000->	29 8360.WO	30	---	---	---	---	29 8323.G0	60	29 8324.V0	82	29 8325.A0	106	2916111.B0	114
ZIP 50 4T	29 8360.WO	30	---	---	---	---	29 8323.G0	60	29 8324.V0	82	29 8325.A0	106	2916111.B0	114
ZIP Fast Rider 50 2T	29 8360.WO	30	---	---	---	---	29 8323.G0	60	29 8324.V0	82	29 8325.A0	106	2916111.B0	114
ZIP SP 50 2T LC	29 8360.WO	30	---	---	---	---	29 8323.G0	60	29 8324.V0	82	29 8325.A0	106	2916111.B0	114
RIZZATO														
VAMOS 50	29 7047.WO	30	29 7045.Y0	35	29 7046.R0	40	---	---	---	---	---	---	---	---
SUZUKI														
ADDRESS AH 50 2T	29 7047.WO	30	29 7045.Y0	35	29 7046.R0	40	---	---	---	---	---	---	---	---
AP 50 2T	29 7047.WO	30	29 7045.Y0	35	29 7046.R0	40	---	---	---	---	---	---	---	---
ESTILETE - UF 50 2T	29 7047.WO	30	29 7045.Y0	35	29 7046.R0	40	---	---	---	---	---	---	---	---
KATANA 50 2T / 50 2T LC	29 7047.WO	30	29 7045.Y0	35	29 7046.R0	40	---	---	---	---	---	---	---	---
SEPIA 50 2T	29 7047.WO	30	29 7045.Y0	35	29 7046.R0	40	---	---	---	---	---	---	---	---
SEPIA ZZ 50 2T	29 7047.WO	30	29 7045.Y0	35	29 7046.R0	40	---	---	---	---	---	---	---	---
STREET MAGIC 50 2T	29 7047.WO	30	29 7045.Y0	35	29 7046.R0	40	---	---	---	---	---	---	---	---
ZILLION 50 2T LC	29 7047.WO	30	29 7045.Y0	35	29 7046.R0	40	---	---	---	---	---	---	---	---
SYM														
DD 50 2T	2912658.WO	5	---	---	29 7043.R0	35	---	---	---	---	---	---	---	---
JET BasiX 50 2T euro 2	2912658.WO	5	---	---	29 7043.R0	35	---	---	---	---	---	---	---	---
JET SportX-S - SportX-R 50 2T euro 2 (T5C/1)	2912658.WO	5	---	---	29 7043.R0	35	---	---	---	---	---	---	---	---
PHONY 50 4T euro 2 (XS1P37QMA-2)	2912658.WO	5	---	---	---	---	29 8323.G0	60	29 8324.V0	82	29 8325.A0	106	2916111.B0	114
VESPA														
ET2 50 2T	29 8360.WO	30	---	---	---	---	29 8323.G0	60	29 8324.V0	82	29 8325.A0	106	2916111.B0	114
ET4 50 4T	29 8360.WO	30	---	---	---	---	29 8323.G0	60	29 8324.V0	82	29 8325.A0	106	2916111.B0	114
LX 50 2T - 50 4T	29 8360.WO	30	---	---	---	---	29 8323.G0	60	29 8324.V0	82	29 8325.A0	106	2916111.B0	114
LX 4V 50 4T euro 2	29 8360.WO	30	---	---	---	---	29 8323.G0	60	29 8324.V0	82	29 8325.A0	106	2916111.B0	114
Primavera 50 2T euro 2 (C533M)	29 8360.WO	30	---	---	---	---	29 8323.G0	60	29 8324.V0	82	29 8325.A0	106	2916111.B0	114
Primavera 4V 50 4T euro 2 (C532M)	29 8360.WO	30	---	---	---	---	29 8323.G0	60	29 8324.V0	82	29 8325.A0	106	2916111.B0	114
S 50 2T euro 2 (C381M)	29 8360.WO	30	---	---	---	---	29 8323.G0	60	29 8324.V0	82	29 8325.A0	106	2916111.B0	114
S 4V 50 4T euro 2 (C386M)	29 8360.WO	30	---	---	---	---	29 8323.G0	60	29 8324.V0	82	29 8325.A0	106	2916111.B0	114
Sprint 50 2T euro 2	29 8360.WO	30	---	---	---	---	29 8323.G0	60	29 8324.V0	82	29 8325.A0	106	2916111.B0	114
Sprint 4V 50 4T euro 2	29 8360.WO	30	---	---	---	---	29 8323.G0	60	29 8324.V0	82	29 8325.A0	106	2916111.B0	114
WT MOTORS														
BILBAO 50 4T (PEDA 139QMB)	2912658.WO	5	29 7042.Y0	30	29 7043.R0	35	---	---	---	---	---	---	---	---
YAMAHA														
AEROX 50 2T LC euro 0-1-2	29 7047.WO	30	29 7045.Y0	35	29 7046.R0	40	---	---	---	---	---	---	---	---
AEROX 100 2T	---	---	2911388.Y0	5	---	---	---	---	---	---	---	---	---	---
AXIS 50 2T	29 7047.WO	30	29 7045.Y0	35	29 7046.R0	40	---	---	---	---	---	---	---	---
BELUGA 50	29 7047.WO	30	29 7045.Y0	35	29 7046.R0	40	---	---	---	---	---	---	---	---
BREEZE 50 2T	29 7047.WO	30	29 7045.Y0	35	29 7046.R0	40	---	---	---	---	---	---	---	---
BW'S 50 2T euro 0-1	29 7047.WO	30	29 7045.Y0	35	29 7046.R0	40	---	---	---	---	---	---	---	---
BW'S 50 2T euro 2 (A137E)	29 8360.WO	30	---	---	---	---	29 8323.G0	60	29 8324.V0	82	29 8325.A0	106	2916111.B0	114
BW'S 100 2T	---	---	2911388.Y0	5	---	---	---	---	---	---	---	---	---	---
BW'S NG 50 2T euro 0-1	29 7047.WO	30	29 7045.Y0	35	29 7046.R0	40	---	---	---	---	---	---	---	---
BW'S NG 50 2T euro 2 (A137E)	29 8360.WO	30	---	---	---	---	29 8323.G0	60	29 8324.V0	82	29 8325.A0	106	2916111.B0	114
BW'S Original/Naked 50 2T euro 2 2010-> (A137E)	29 8360.WO	30	---	---	---	---	29 8323.G0	60	29 8324.V0	82	29 8325.A0	106	2916111.B0	114
CRZ 50 2T	29 7047.WO	30	29 7045.Y0	35	29 7046.R0	40	---	---	---	---	---	---	---	---
CT 50 2T	29 7047.WO	30	29 7045.Y0	35	29 7046.R0	40	---	---	---	---	---	---	---	---
JOG 50 2T	29 7047.WO	30	29 7045.Y0	35	29 7046.R0	40	---	---	---	---	---	---	---	---
JOG ER 50 2T	29 7047.WO	30	29 7045.Y0	35	29 7046.R0	40	---	---	---	---	---	---	---	---
JOG R 50 2T	29 7047.WO	30	29 7045.Y0	35	29 7046.R0	40	---	---	---	---	---	---	---	---
JOG Z 50 2T	29 7047.WO	30	29 7045.Y0	35	29 7046.R0	40	---	---	---	---	---	---	---	---
JOGRR 50 2T LC euro 2	29 7047.WO	30	29 7045.Y0	35	29 7046.R0	40	---	---	---	---	---	---	---	---
NEO'S 50 2T	29 7047.WO	30	29 7045.Y0	35	29 7046.R0	40	---	---	---	---	---	---	---	---
NEO'S 100 2T	---	---	2911388.Y0	5	---	---	---	---	---	---	---	---	---	---
SLIDER 50 2T	29 7047.WO	30	29 7045.Y0	35	29 7046.R0	40	---	---	---	---	---	---	---	---

(*) % Increase in rigidy compared to the original

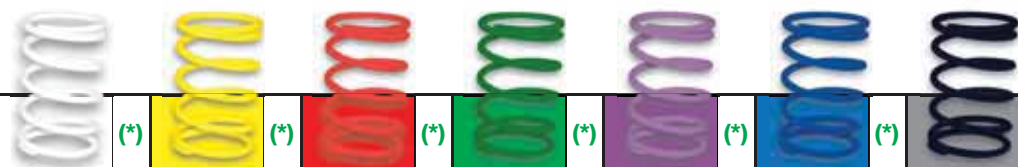

SCOOTER 50 > 110		(*)		(*)		(*)		(*)		(*)		(*)
SPY 50 2T	29 7047.WO	30	29 7045.YO	35	29 7046.RO	40	---	---	---	---	---	---
WHY 50 2T	29 7047.WO	30	29 7045.YO	35	29 7046.RO	40	---	---	---	---	---	---
ZEST 50 2T	29 7047.WO	30	29 7045.YO	35	29 7046.RO	40	---	---	---	---	---	---
ZUMA 50 2T	29 7047.WO	30	29 7045.YO	35	29 7046.RO	40	---	---	---	---	---	---
ATV - QUAD 50 > 90												
AEON MOTOR												
COBRA 50 2T (AT70)	29 7047.WO	30	29 7045.YO	35	29 7046.RO	40	---	---	---	---	---	---
DINLI												
T.REX 50 2T	29 7047.WO	30	29 7045.YO	35	29 7046.RO	40	---	---	---	---	---	---
DRR												
DRX 90 2T	29 7047.WO	30	29 7045.YO	35	29 7046.RO	40	---	---	---	---	---	---
E-TON												
VIPER RXL 50 - 90 2T	29 7047.WO	30	29 7045.YO	35	29 7046.RO	40	---	---	---	---	---	---
KYMCO												
MXer 50 2T	2912658.WO	5	---	---	29 7043.RO	35	---	---	---	---	---	---
LAVERDA												
QUASAR 50 2T (AR 03)	29 7047.WO	30	29 7045.YO	35	29 7046.RO	40	---	---	---	---	---	---
SUZUKI												
SPORT 80 2T	29 7047.WO	30	29 7045.YO	35	29 7046.RO	40	---	---	---	---	---	---
CICLOMOTORI 50												
HONDA												
MTX (automatico) 50	---	---	29 7042.YO	30	29 7043.RO	35	---	---	---	---	---	---
NSR (automatico) 50	---	---	29 7042.YO	30	29 7043.RO	35	---	---	---	---	---	---
PX 50	---	---	29 7042.YO	30	29 7043.RO	35	---	---	---	---	---	---
WALLAROO 50	---	---	29 7042.YO	30	29 7043.RO	35	---	---	---	---	---	---
PEUGEOT												
FOX 50	---	---	29 7042.YO	30	29 7043.RO	35	---	---	---	---	---	---
PIAGGIO												
BOSS 50	---	---	29 7009.YO	30	29 6955.RO	35	---	---	---	---	---	---
BRAVO 50	---	---	29 7009.YO	30	29 6955.RO	35	---	---	---	---	---	---
CIAO 50	---	---	29 7009.YO	30	29 6955.RO	35	---	---	---	---	---	---
CIAO PX 50	---	---	29 7009.YO	30	29 6955.RO	35	---	---	---	---	---	---
GRILLO 50	---	---	29 7009.YO	30	29 6955.RO	35	---	---	---	---	---	---
SI 50	---	---	29 7009.YO	30	29 6955.RO	35	---	---	---	---	---	---
SUPERBRAVO 50	---	---	29 7009.YO	30	29 6955.RO	35	---	---	---	---	---	---

Products to be used exclusively for racing in places specially designed for such activity according to the regulations of the competent sporting authorities. We accept no liability resulting from improper use.

(*) % Increase in rigidity compared to the original

VARIABLE-SPEED DRIVE ADJUSTER SPRING



MALOSSI

for VARIATOR MAXI SCOOTER



New

Springs for Multivar and original variator

Silicon-steel springs with high carbon content, heat-treated, dynamically balanced, kiln painted, designed and calculated for each specific application.

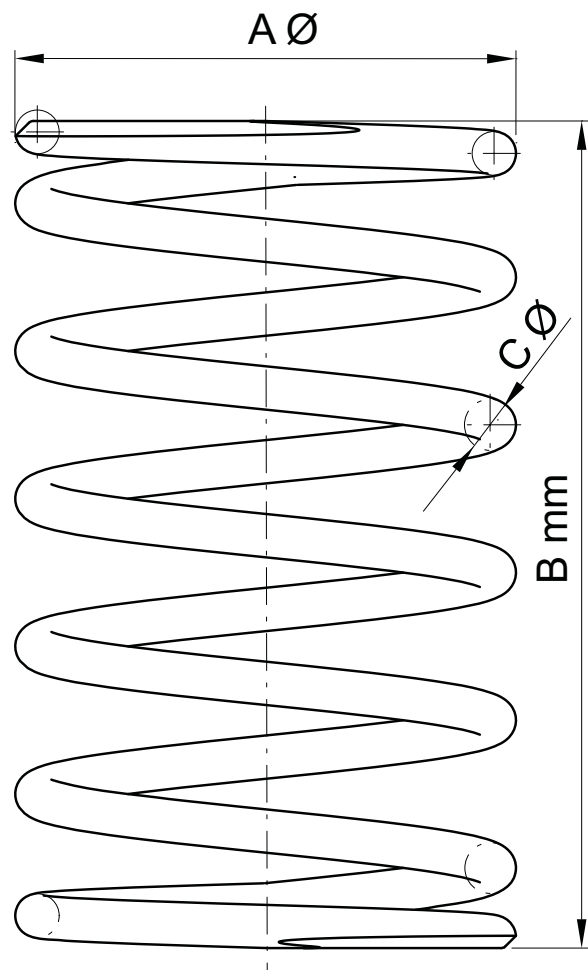

CODE	€	SPRING SIZES			(K) = spring stiffness
		A Ø	B mm	C Ø	
29 7046.R0	5,91	53,7	110	3,9	4,7k
2914203.W0	10,00	56,8	138	3,8	2,8k
2911266.Y0	10,71	57,5	120	4,5	5,5k
29 8360.W0	6,50	57,8	118	4	3,3k
2912480.W0	7,00	57,8	150	4,2	4k
2916464.Y0	10,00	58	128	4,3	5,5k
2916465.R0	10,00	58	135	4,3	5,5k
2915553.Y0	11,85	58,3	105	4,3	7,3k
2916498.R0	10,00	58,6	112	4,3	7,2k
2911384.Y0	10,71	58,7	75	5	13,6k
2915464.W0	15,45	60	95	5	9,5k
2912647.Y0	10,00	63,1	120	4,6	4,5k
2911390.B0	10,71	65	106	4,5	6,2k
2916460.R0	11,00	65	108	4,7	7,5k
2916459.Y0	9,50	65	112	4,6	6,8k
2911478.W0	10,71	65	116	4,5	6,2k
29 9976.R0	10,71	65,4	100	5,2	9k
2911084.W0	10,71	65,7	170	4,7	4,3k
29 9975.Y0	10,71	67	115	5,2	7,8k
2914120.W0	14,22	67,2	120	5,2	10,3k
2911074.Y0	10,71	67,2	181	4,7	3,6k
2913316.W0	10,71	67,4	107	5,2	10,2k
2916497.R0	11,00	67,6	120	5,2	10,1k
2916484.Y0	11,00	67,7	112	5,2	10,1k
2916113.W0	12,00	67,9	120	5,4	8,8k
2911072.W0	10,71	68	100	5,2	9,9k
2914712.W0	14,19	68	120	5,2	9,9k
2914401.G0	15,16	70,3	156,5	5,5	6,8k
2914023.R0	15,16	70,5	126	6,5	13,7k
2914024.Y0	15,16	70,5	138	6	9,7k
2912772.W0	15,16	71	129	6	11,9k
2915315.W0	15,97	73	96	6	14,5k
2916114.W0	14,00	75,7	160	5,7	7,7k
2916507.Y0	14,00	77,2	153	5,7	7,3k
2916508.R0	14,00	77,2	160	5,7	7,3k
2913003.W0	13,54	77,7	130	6	8,9k
2911429.Y0	11,50	78	150	5,5	6k
2913344.W0	14,19	80,4	115	6,5	11,2k
2912478.W0	11,50	81	130	7	15k
2914121.W0	18,50	85,1	205	6,5	7,4k
2915497.W0	25,75	88	135	7	11,4k

ATTENTION:

a complete description of the spring desired is needed when ordering.

Es. **2916465.R0** Red



.R0 Red



.W0 White



.Y0 Yellow



.G0 Green







.B0 Black

New



MAXISCOOTER			(K)		(K)		(K)		(K)		(K)	
APRILIA	ATLANTIC - Arrecife 125 4T LC	2911478.WO	6,2k	2916459.YO	6,8k	2916460.RO	7,5k	---	---	---	---	
	ATLANTIC 200 4T LC (PIAGGIO M234M)	2911478.WO	6,2k	2916459.YO	6,8k	2916460.RO	7,5k	---	---	---	---	
	ATLANTIC - Arrecife 250 4T LC (PIAGGIO M237M)	2911478.WO	6,2k	2916459.YO	6,8k	2916460.RO	7,5k	---	---	---	---	
	ATLANTIC SPRINT - Arrecife 400 4T LC (PIAGGIO M348M)	2913003.WO	8,9k	2916507.YO	7,3k	2916508.RO	7,3k	---	---	---	---	
	ATLANTIC 500 4T LC	2913003.WO	8,9k	2916507.YO	7,3k	2916508.RO	7,3k	---	---	---	---	
	ATLANTIC SPRINT - Arrecife 500 4T LC (PIAGGIO M273M)	2913003.WO	8,9k	2916507.YO	7,3k	2916508.RO	7,3k	---	---	---	---	
	LEONARDO 125 - 150 4T LC	---	---	2911266.YO	5,5k	---	---	---	---	---	---	---
	LEONARDO 250 4T LC	---	---	29 9975.YO	7,8k	29 9976.RO	9k	---	---	---	---	---
	LEONARDO 300 4T LC	---	---	29 9975.YO	7,8k	---	---	---	---	---	---	---
	MOJITO RY 125 4T (LEADER)	2911478.WO	6,2k	2916459.YO	6,8k	2916460.RO	7,5k	---	---	---	---	
	SCARABEO 125 4T LC (PIAGGIO)	2911478.WO	6,2k	2916459.YO	6,8k	2916460.RO	7,5k	---	---	---	---	
	SCARABEO 125 - 150 4T LC (ROTAX)	---	---	2911266.YO	5,5k	---	---	---	---	---	---	---
	SCARABEO 200 4T LC (ROTAX)	---	---	2911266.YO	5,5k	---	---	---	---	---	---	---
	SCARABEO 250 4T LC (PIAGGIO M285M)	2911478.WO	6,2k	2916459.YO	6,8k	2916460.RO	7,5k	---	---	---	---	
	SCARABEO 400 ie 4T LC 2007->	2913003.WO	8,9k	2916507.YO	7,3k	2916508.RO	7,3k	---	---	---	---	
	SCARABEO 500 4T LC	2913003.WO	8,9k	2916507.YO	7,3k	2916508.RO	7,3k	---	---	---	---	
	SCARABEO Light 125 4T LC euro 3 (APRILIA BA03)	2911478.WO	6,2k	2916459.YO	6,8k	2916460.RO	7,5k	---	---	---	---	
	SCARABEO Light 125 ie 4T LC euro 3 (APRILIA BB01)	2911478.WO	6,2k	2916459.YO	6,8k	2916460.RO	7,5k	---	---	---	---	
	SCARABEO Light 200 ie 4T LC euro 3 (APRILIA CA03-CB01)	2911478.WO	6,2k	2916459.YO	6,8k	2916460.RO	7,5k	---	---	---	---	
	SCARABEO Light 250 ie 4T LC 2007->	2911478.WO	6,2k	2916459.YO	6,8k	2916460.RO	7,5k	---	---	---	---	
	SCARABEO Light 400 ie 4T LC 2007->	2913003.WO	8,9k	2916507.YO	7,3k	2916508.RO	7,3k	---	---	---	---	
	SCARABEO Light 500 ie 4T LC 2007->	2913003.WO	8,9k	2916507.YO	7,3k	2916508.RO	7,3k	---	---	---	---	
	SCARABEO Special 300 ie 4T LC euro 3 (PIAGGIO M288M)	2911478.WO	6,2k	2916459.YO	6,8k	2916460.RO	7,5k	---	---	---	---	
	SPORTCITY 125 4T LC (PIAGGIO M281M)	2911478.WO	6,2k	2916459.YO	6,8k	2916460.RO	7,5k	---	---	---	---	
	SPORTCITY 200 4T LC euro 3 (PIAGGIO M288M)	2911478.WO	6,2k	2916459.YO	6,8k	2916460.RO	7,5k	---	---	---	---	
	SPORTCITY 250 ie 4T LC euro 3 (PIAGGIO M288M)	2911478.WO	6,2k	2916459.YO	6,8k	2916460.RO	7,5k	---	---	---	---	
	SPORTCITY CUBE 300 ie 4T LC euro 3 (LEADER M28LM)	2911478.WO	6,2k	2916459.YO	6,8k	2916460.RO	7,5k	---	---	---	---	
	SPORTCITY ONE 125 4T (LEADER M38AM)	2911478.WO	6,2k	2916459.YO	6,8k	2916460.RO	7,5k	---	---	---	---	
	SR 125 - 150 2T	2911478.WO	6,2k	2916459.YO	6,8k	2916460.RO	7,5k	---	---	---	---	
		2911084.WO	4,3k	---	---	---	---	---	---	---	---	---
	SR MAX 125 ie 4T LC euro 3	2911478.WO	6,2k	2916459.YO	6,8k	2916460.RO	7,5k	---	---	---	---	---
	SR MAX 300 ie 4T LC euro 3	2911478.WO	6,2k	2916459.YO	6,8k	2916460.RO	7,5k	---	---	---	---	---
SR MOTARD 125 4T euro 3	2911478.WO	6,2k	2916459.YO	6,8k	2916460.RO	7,5k	---	---	---	---	---	
SRV 850 ie 4T LC euro 3 (PIAGGIO M554M)	2914121.WO	7,4k	---	---	---	---	---	---	---	---	---	
BENELLI	ADIVA 125 - 150 4T (LEADER)	2911478.WO	6,2k	2916459.YO	6,8k	2916460.RO	7,5k	---	---	---	---	
	ADIVA AD 250 4T LC euro 2	2911478.WO	6,2k	2916459.YO	6,8k	2916460.RO	7,5k	---	---	---	---	
	CAFFÈNERO 150 4T LC euro 3 (QJ158MJ)	2912480.WO	4k	2916464.YO	5,5k	2916465.RO	5,5k	---	---	---	---	
	VELVET 125 - 150 4T LC	---	---	2912647.YO	4,5k	---	---	---	---	---	---	
	VELVET 250 4T LC	---	---	29 9975.YO	7,8k	29 9976.RO	9k	---	---	---	---	
VELVET DUSK 400 4T LC	---	---	2911429.YO	6k	---	---	---	---	---	---		
BETA	EIKON 125 - 150 4T LC	---	---	2911384.YO	13,6k	---	---	---	---	---	---	
BMW	C Sport 600 ie 4T LC euro 4	2915497.WO	11,4k	---	---	---	---	---	---	---	---	
	C GT 650 ie 4T LC euro 4	2915497.WO	11,4k	---	---	---	---	---	---	---	---	
CF MOTO	URBAN R 150 4T LC (1P 58 MJ)	2912480.WO	4k	2916464.YO	5,5k	2916465.RO	5,5k	---	---	---	---	
DERBI	BOULEVARD 125 - 150 4T (LEADER)	2911478.WO	6,2k	2916459.YO	6,8k	2916460.RO	7,5k	---	---	---	---	
	BOULEVARD 200 4T (PIAGGIO M387M)	2911478.WO	6,2k	2916459.YO	6,8k	2916460.RO	7,5k	---	---	---	---	
	GP1 125 4T LC euro 2-3	2911478.WO	6,2k	2916459.YO	6,8k	2916460.RO	7,5k	---	---	---	---	
	GP1 250 4T LC euro 2-3	2911478.WO	6,2k	2916459.YO	6,8k	2916460.RO	7,5k	---	---	---	---	
	RAMBLA 125 4T LC euro 3 (PIAGGIO M287M)	2911478.WO	6,2k	2916459.YO	6,8k	2916460.RO	7,5k	---	---	---	---	
	RAMBLA 250 ie 4T LC euro 3	2911478.WO	6,2k	2916459.YO	6,8k	2916460.RO	7,5k	---	---	---	---	
	RAMBLA i 300 ie 4T LC euro 3 (PIAGGIO)	2911478.WO	6,2k	2916459.YO	6,8k	2916460.RO	7,5k	---	---	---	---	
GARELLI	XO' 125 - 150 ie 4T euro 3	2912480.WO	4k	2916464.YO	5,5k	2916465.RO	5,5k	---	---	---	---	
GILERA	DNA 125 4T LC	2911478.WO	6,2k	2916459.YO	6,8k	2916460.RO	7,5k	---	---	---	---	
	DNA 180 4T LC	2911478.WO	6,2k	2916459.YO	6,8k	2916460.RO	7,5k	---	---	---	---	
	FUOCO 500 ie 4T LC euro 3	2913003.WO	8,9k	2916507.YO	7,3k	2916508.RO	7,3k	---	---	---	---	
	GP 800 4T LC (PIAGGIO M554M)	2914121.WO	7,4k	---	---	---	---	---	---	---	---	
	NEXUS 125 4T LC euro 3	2911478.WO	6,2k	2916459.YO	6,8k	2916460.RO	7,5k	---	---	---	---	
	NEXUS 125 ie 4T LC euro 3	2911478.WO	6,2k	2916459.YO	6,8k	2916460.RO	7,5k	---	---	---	---	
	NEXUS 250 ie 4T LC euro 3	2911478.WO	6,2k	2916459.YO	6,8k	2916460.RO	7,5k	---	---	---	---	
	NEXUS 300 ie 4T LC euro 3	2911478.WO	6,2k	2916459.YO	6,8k	2916460.RO	7,5k	---	---	---	---	

New

MAXISCOOTER			(K)		(K)		(K)		(K)		(K)
MAXISCOOTER	NEXUS 500 ie 4T LC euro 2-3	2913003.WO	8,9k	2916507.YO	7,3k	2916508.RO	7,3k	---	---	---	---
	RUNNER FX 125 2T LC	2911478.WO	6,2k	2916459.YO	6,8k	2916460.RO	7,5k	---	---	---	---
		2911084.WO	4,3k	---	---	---	---	---	---	---	---
	RUNNER FXR - SP 180 2T LC	2911478.WO	6,2k	2916459.YO	6,8k	2916460.RO	7,5k	---	---	---	---
		2911084.WO	4,3k	---	---	---	---	---	---	---	---
	RUNNER ST 125 4T LC euro 3	2911478.WO	6,2k	2916459.YO	6,8k	2916460.RO	7,5k	---	---	---	---
	RUNNER ST 200 4T LC euro 3	2911478.WO	6,2k	2916459.YO	6,8k	2916460.RO	7,5k	---	---	---	---
	RUNNER VX 125 4T LC	2911478.WO	6,2k	2916459.YO	6,8k	2916460.RO	7,5k	---	---	---	---
	RUNNER VXR 180 4T LC	2911478.WO	6,2k	2916459.YO	6,8k	2916460.RO	7,5k	---	---	---	---
	RUNNER VXR 200 4T LC	2911478.WO	6,2k	2916459.YO	6,8k	2916460.RO	7,5k	---	---	---	---
	TYPHOON 125 2T	2911478.WO	6,2k	2916459.YO	6,8k	2916460.RO	7,5k	---	---	---	---
		2911084.WO	4,3k	---	---	---	---	---	---	---	---
	TYPHOON X 125 2T	2911478.WO	6,2k	2916459.YO	6,8k	2916460.RO	7,5k	---	---	---	---
		2911084.WO	4,3k	---	---	---	---	---	---	---	---
	HONDA	@ 125 - 150 4T LC	2912480.WO	4k	2916464.YO	5,5k	2916465.RO	5,5k	---	---	---
DYLAN 125 - 150 4T LC		2912480.WO	4k	2916464.YO	5,5k	2916465.RO	5,5k	---	---	---	---
FORESIGHT 250 4T LC		2911072.WO	9,9k	2911074.YO	3,6k	---	---	---	---	---	---
FORZA ABS 300 ie 4T LC (NF04E)		2913316.WO	10,2k	2916484.YO	10,1k	2916497.RO	10,1k	---	---	---	---
PANTHEON 125 - 150 2T LC		2911072.WO	9,9k	2911074.YO	3,6k	---	---	---	---	---	---
PANTHEON 125 - 150 ie 4T LC		2912480.WO	4k	2916464.YO	5,5k	2916465.RO	5,5k	---	---	---	---
PCX 125 - 150 ie 4T LC euro 3		---	---	2915553.YO	7,3k	2916498.RO	7,2k	---	---	---	---
PS 125 - 150 ie 4T LC euro 3		2912480.WO	4k	2916464.YO	5,5k	2916465.RO	5,5k	---	---	---	---
SH - SH Scoopy 125 - 150 4T LC		2912480.WO	4k	2916464.YO	5,5k	2916465.RO	5,5k	---	---	---	---
SH I 125 - 150 ie 4T LC		2912480.WO	4k	2916464.YO	5,5k	2916465.RO	5,5k	---	---	---	---
SH I - SH I Scoopy 300 ie 4T LC <-2014 (NF02E)		2913316.WO	10,2k	2916484.YO	10,1k	2916497.RO	10,1k	---	---	---	---
SH i ABS 125 ie 4T LC euro 3 2013-> (JF41E)		2912480.WO	4k	2916464.YO	5,5k	2916465.RO	5,5k	---	---	---	---
SH i ABS 150 ie 4T LC euro 3 2013-> (KF13E)		---	---	2915553.YO	7,3k	2916498.RO	7,2k	---	---	---	---
SH mode 125 ie 4T LC euro 3 (JF51E)		---	---	2915553.YO	7,3k	2916498.RO	7,2k	---	---	---	---
SILVER WING 400 4T LC		2912478.WO	15k	---	---	---	---	---	---	---	---
SILVER WING 600 4T LC		2912478.WO	15k	---	---	---	---	---	---	---	---
S-Wing 125 - 150 ie 4T LC euro 3		2912480.WO	4k	2916464.YO	5,5k	2916465.RO	5,5k	---	---	---	---
SW-T 400 4T LC euro 3 (NF01E)		2912478.WO	15k	---	---	---	---	---	---	---	---
SW-T 600 4T LC euro 3 (PF01E)		2912478.WO	15k	---	---	---	---	---	---	---	---
ITALJET	DRAGSTER 125 2T LC	2911478.WO	6,2k	2916459.YO	6,8k	2916460.RO	7,5k	---	---	---	---
		2911084.WO	4,3k	---	---	---	---	---	---	---	---
	DRAGSTER 180 2T LC	2911478.WO	6,2k	2916459.YO	6,8k	2916460.RO	7,5k	---	---	---	---
		2911084.WO	4,3k	---	---	---	---	---	---	---	---
	JET SET 125 - 150 4T (LEADER)	2911478.WO	6,2k	2916459.YO	6,8k	2916460.RO	7,5k	---	---	---	---
	JUPITER 125 - 150 4T LC	---	---	2912647.YO	4,5k	---	---	---	---	---	---
	JUPITER 250 4T LC	---	---	29 9975.YO	7,8k	29 9976.RO	9k	---	---	---	---
	MILLENNIUM 125 - 150 4T LC	---	---	2912647.YO	4,5k	---	---	---	---	---	---
	TORPEDO 125 - 150 4T (LEADER)	2911478.WO	6,2k	2916459.YO	6,8k	2916460.RO	7,5k	---	---	---	---
	KAWASAKI	J 300 ie 4T LC euro 3 (WS60)	2914712.WO	9,9k	---	---	---	---	---	---	---
KEEWAY	LOGIK 125 4T LC euro 3 (QJ153MI-2)	2912480.WO	4k	2916464.YO	5,5k	2916465.RO	5,5k	---	---	---	---
	OUTLOOK 125 - 150 4T LC	2912480.WO	4k	2916464.YO	5,5k	2916465.RO	5,5k	---	---	---	---
	ZAHARA 125 4T euro 3 (QJ153 QMI-7B)	2912480.WO	4k	2916464.YO	5,5k	2916465.RO	5,5k	---	---	---	---
KYMCO	AGILITY 125 - 150 4T euro 3	2912480.WO	4k	2916464.YO	5,5k	2916465.RO	5,5k	---	---	---	---
	AGILITY R16 125 - 150 4T euro 3	2912480.WO	4k	2916464.YO	5,5k	2916465.RO	5,5k	---	---	---	---
	AGILITY R16 i 200 4T LC euro 3 (KF40-KF40B)	2912480.WO	4k	2916464.YO	5,5k	2916465.RO	5,5k	---	---	---	---
	AGILITY RS 125 4T euro 3 (KN25SR)	2912480.WO	4k	2916464.YO	5,5k	2916465.RO	5,5k	---	---	---	---
	BET & WIN 125 - 150 4T LC	---	---	2911384.YO	13,6k	---	---	---	---	---	---
	BET & WIN 250 4T LC	---	---	2911074.YO	3,6k	---	---	---	---	---	---
	DINK 125 - 150 4T LC euro 0-1-2	---	---	2911384.YO	13,6k	---	---	---	---	---	---
	DINK Street 125 ie 4T LC euro 3 (SK25)	2912480.WO	4k	2916464.YO	5,5k	2916465.RO	5,5k	---	---	---	---
	DINK Street 200 ie 4T LC euro 3 (SK40)	2913316.WO	10,2k	2916484.YO	10,1k	2916497.RO	10,1k	---	---	---	---
	DINK Street 300 ie 4T LC euro 3 (SK60)	2913316.WO	10,2k	2916484.YO	10,1k	2916497.RO	10,1k	---	---	---	---
	DINK Street 300 ie 4T LC euro 3 2012-> (SK60A)	2914712.WO	9,9k	---	---	---	---	---	---	---	---
	DOWNTOWN 125 ie 4T LC euro 3 (SK25)	2912480.WO	4k	2916464.YO	5,5k	2916465.RO	5,5k	---	---	---	---
	DOWNTOWN 200 ie 4T LC euro 3 (SK40)	2913316.WO	10,2k	2916484.YO	10,1k	2916497.RO	10,1k	---	---	---	---
	DOWNTOWN 300 ie 4T LC euro 3 (SK60)	2913316.WO	10,2k	2916484.YO	10,1k	2916497.RO	10,1k	---	---	---	---

New



MAXISCOOTER			(K)		(K)		(K)		(K)		(K)
DOWNTOWN 300 ie 4T LC euro 3 2012-> (SK60A)	2914712.W0	9,9k	---	---	---	---	---	---	---	---	---
DOWNTOWN i ABS 350 ie 4T LC euro 3 (SK64)	2914712.W0	9,9k	---	---	---	---	---	---	---	---	---
G6E 125 - 150 ie 4T LC euro 3	2912480.W0	4k	2916464.Y0	5,5k	2916465.R0	5,5k	---	---	---	---	---
G-DINK 300 ie 4T LC euro 3 (SH60)	2914712.W0	9,9k	---	---	---	---	---	---	---	---	---
GRAND DINK 125 -150 4T LC euro 0-1-2	---	---	2911384.Y0	13,6k	---	---	---	---	---	---	---
GRAND DINK 250 4T LC	---	---	2911074.Y0	3,6k	---	---	---	---	---	---	---
K-XCT 125 ie 4T LC euro 3	2912480.W0	4k	2916464.Y0	5,5k	2916465.R0	5,5k	---	---	---	---	---
K-XCT 300 ie 4T LC euro 3 (SK60B)	2914712.W0	9,9k	---	---	---	---	---	---	---	---	---
LIKE 125 4T euro 3 (KA40)	2912480.W0	4k	2916464.Y0	5,5k	2916465.R0	5,5k	---	---	---	---	---
LIKE 200 ie 4T euro 3 (KA40)	2912480.W0	4k	2916464.Y0	5,5k	2916465.R0	5,5k	---	---	---	---	---
MOVIE 125 4T euro 3	2912480.W0	4k	2916464.Y0	5,5k	2916465.R0	5,5k	---	---	---	---	---
NIKITA 200 ie 4T LC euro 3	2913316.W0	10,2k	2916484.Y0	10,1k	2916497.R0	10,1k	---	---	---	---	---
NIKITA 300 ie 4T LC euro 3	2914712.W0	9,9k	---	---	---	---	---	---	---	---	---
PEOPLE - PEOPLE S 125 4T euro 3	2912480.W0	4k	2916464.Y0	5,5k	2916465.R0	5,5k	---	---	---	---	---
PEOPLE 150 4T	2912480.W0	4k	2916464.Y0	5,5k	2916465.R0	5,5k	---	---	---	---	---
PEOPLE - PEOPLE S 250 4T LC euro 2	---	---	2911074.Y0	3,6k	---	---	---	---	---	---	---
PEOPLE GTi 125 ie 4T LC euro 3 (BF25)	2912480.W0	4k	2916464.Y0	5,5k	2916465.R0	5,5k	---	---	---	---	---
PEOPLE GTi 200 ie 4T LC euro 3 (BF40)	2914712.W0	9,9k	---	---	---	---	---	---	---	---	---
PEOPLE GTi 300 ie 4T LC euro 3 (BF60)	2914712.W0	9,9k	---	---	---	---	---	---	---	---	---
PEOPLE One 125 ie 4T euro 3 (KM25)	2912480.W0	4k	2916464.Y0	5,5k	2916465.R0	5,5k	---	---	---	---	---
PEOPLE S 200 4T (BA 40)	2912480.W0	4k	2916464.Y0	5,5k	2916465.R0	5,5k	---	---	---	---	---
PEOPLE S 300 ie 4T LC euro 3 (BB60)	2914712.W0	9,9k	---	---	---	---	---	---	---	---	---
RACING 125 - 150 ie 4T LC euro 3	2912480.W0	4k	2916464.Y0	5,5k	2916465.R0	5,5k	---	---	---	---	---
SUPER 8 125 4T euro 3 (KL25)	2912480.W0	4k	2916464.Y0	5,5k	2916465.R0	5,5k	---	---	---	---	---
SUPER DINK 125 ie 4T LC euro 3 (SK25)	2912480.W0	4k	2916464.Y0	5,5k	2916465.R0	5,5k	---	---	---	---	---
SUPER DINK 200 ie 4T LC euro 3 (SK40)	2913316.W0	10,2k	2916484.Y0	10,1k	2916497.R0	10,1k	---	---	---	---	---
SUPER DINK 300 ie 4T LC euro 3 (SK60)	2913316.W0	10,2k	2916484.Y0	10,1k	2916497.R0	10,1k	---	---	---	---	---
SUPER DINK 300 ie 4T LC euro 3 2012-> (SK60A)	2914712.W0	9,9k	---	---	---	---	---	---	---	---	---
VIVIO 125 - 150 4T	2912480.W0	4k	2916464.Y0	5,5k	2916465.R0	5,5k	---	---	---	---	---
XCITING 250 4T LC euro 2	---	---	2911074.Y0	3,6k	---	---	---	---	---	---	---
XCITING - XCITING R 300 ie 4T LC euro 3	2914712.W0	9,9k	---	---	---	---	---	---	---	---	---
XCITING 400 ie 4T LC euro 3 (SK80)	2916113.W0	8,8k	---	---	---	---	---	---	---	---	---
XCITING 500 4T LC euro 2-3	2913344.W0	11,2k	---	---	---	---	---	---	---	---	---
XCITING R 500 ie 4T LC euro 3 (SB A0)	2913344.W0	11,2k	---	---	---	---	---	---	---	---	---
YAGER GT 300 ie 4T LC euro 3 (SH60)	2914712.W0	9,9k	---	---	---	---	---	---	---	---	---
YUP 250 4T LC (SH 50 D)	---	---	2911074.Y0	3,6k	---	---	---	---	---	---	---
LINHAI MONARCH 125 - 150 4T	---	---	2911266.Y0	5,5k	---	---	---	---	---	---	---
MALAGUTI BLOG 125 - 160 ie 4T LC euro 3	2912480.W0	4k	2916464.Y0	5,5k	2916465.R0	5,5k	---	---	---	---	---
CENTRO 125 - 160 ie 4T LC euro 3	2912480.W0	4k	2916464.Y0	5,5k	2916465.R0	5,5k	---	---	---	---	---
CIAK MASTER 125 - 150 4T	2912480.W0	4k	2916464.Y0	5,5k	2916465.R0	5,5k	---	---	---	---	---
CIAK MASTER 200 4T	2912480.W0	4k	2916464.Y0	5,5k	2916465.R0	5,5k	---	---	---	---	---
F18 WARRIOR 125 - 150 4T LC	---	---	2911384.Y0	13,6k	---	---	---	---	---	---	---
MADISON 125 - 150 4T LC (YAMAHA)	---	---	2912647.Y0	4,5k	---	---	---	---	---	---	---
MADISON 180 4T LC (PIAGGIO)	2911478.W0	6,2k	2916459.Y0	6,8k	2916460.R0	7,5k	---	---	---	---	---
MADISON 200 4T LC (PIAGGIO)	2911478.W0	6,2k	2916459.Y0	6,8k	2916460.R0	7,5k	---	---	---	---	---
MADISON 250 4T LC (YAMAHA)	---	---	29 9975.Y0	7,8k	29 9976.R0	9k	---	---	---	---	---
MADISON 3 125 4T LC (PIAGGIO)	2911478.W0	6,2k	2916459.Y0	6,8k	2916460.R0	7,5k	---	---	---	---	---
MADISON 3 250 4T LC (PIAGGIO)	2911478.W0	6,2k	2916459.Y0	6,8k	2916460.R0	7,5k	---	---	---	---	---
MADISON K 400 4T LC	---	---	2911429.Y0	6k	---	---	---	---	---	---	---
MADISON RS 250 4T LC (PIAGGIO M237M)	2911478.W0	6,2k	2916459.Y0	6,8k	2916460.R0	7,5k	---	---	---	---	---
PassWord CK 250 4T LC	---	---	29 9975.Y0	7,8k	---	---	---	---	---	---	---
PHANTOM MAX 125 4T LC (YAMAHA)	---	---	2912647.Y0	4,5k	---	---	---	---	---	---	---
PHANTOM MAX 200 4T LC (PIAGGIO)	2911478.W0	6,2k	2916459.Y0	6,8k	2916460.R0	7,5k	---	---	---	---	---
PHANTOM MAX 250 4T LC (PIAGGIO M361M)	2911478.W0	6,2k	2916459.Y0	6,8k	2916460.R0	7,5k	---	---	---	---	---
SPIDERMAX GT 500 4T LC (PIAGGIO M341M)	2913003.W0	8,9k	2916507.Y0	7,3k	2916508.R0	7,3k	---	---	---	---	---
MBK CITYLINER 125 ie 4T LC euro 3	---	---	2912647.Y0	4,5k	---	---	---	---	---	---	---
DOODO 125 - 150 4T LC	---	---	2912647.Y0	4,5k	---	---	---	---	---	---	---
FLAME 125 4T	---	---	2912647.Y0	4,5k	---	---	---	---	---	---	---
KILIBRE 300 4T LC (H314E)	---	---	29 9975.Y0	7,8k	---	---	---	---	---	---	---
SKYCRUISER 125 ie 4T LC euro 3	---	---	2912647.Y0	4,5k	---	---	---	---	---	---	---





New

MAXISCOOTER			(K)		(K)		(K)		(K)		(K)
	SKYLINER 125 - 150 4T LC	---		2912647.YO	4,5k	---		---		---	
	SKYLINER 250 4T LC	---		29 9975.YO	7,8k	29 9976.RO	9k	---		---	
	THUNDER 125 - 150 4T LC	---		2912647.YO	4,5k	---		---		---	
	X OVER 125 ie 4T euro 3 (E3G3E)	---		2912647.YO	4,5k	---		---		---	
OVER	THOR 125 4T euro 3 (LJ1P52QMI)	---		2911266.YO	5,5k	---		---		---	
PEUGEOT	ELYSEO 125 - 150 4T LC	---		---		---		---		2911390.BO	6,2k
	GEPOLIS 250 ie 4T LC euro 3	2911478.WO	6,2k	2916459.YO	6,8k	2916460.RO	7,5k	---		---	
	GEPOLIS R/GT 300 ie 4T LC euro 3	2911478.WO	6,2k	2916459.YO	6,8k	2916460.RO	7,5k	---		---	
	GEPOLIS 400 4T LC euro 3	2913003.WO	8,9k	2916507.YO	7,3k	2916508.RO	7,3k	---		---	
	GeoRS 300 ie 4T LC euro 3 (PIAGGIO M28MM)	2911478.WO	6,2k	2916459.YO	6,8k	2916460.RO	7,5k	---		---	
	LXR 125 4T LC euro 3 (MB)	---		2911266.YO	5,5k	---		---		---	
	METROPOLIS 400 ie 4T LC euro 3 (P6A)	2913003.WO	8,9k	2916507.YO	7,3k	2916508.RO	7,3k	---		---	
	SATELIS 250 4T LC euro 3	2911478.WO	6,2k	2916459.YO	6,8k	2916460.RO	7,5k	---		---	
	SATELIS 400 4T LC euro 3 <-2014 (PIAGGIO)	2913003.WO	8,9k	2916507.YO	7,3k	2916508.RO	7,3k	---		---	
	SATELIS 400 4T LC euro 3 2015->	2913003.WO	8,9k	2916507.YO	7,3k	2916508.RO	7,3k	---		---	
	SATELIS 500 4T LC euro 3	2913003.WO	8,9k	2916507.YO	7,3k	2916508.RO	7,3k	---		---	
	SATELIS RS 400 4T LC euro 3 2015->	2913003.WO	8,9k	2916507.YO	7,3k	2916508.RO	7,3k	---		---	
	SV 250 4T LC	2911072.WO	9,9k	2911074.YO	3,6k	---		---		---	
	TWEET 125 4T euro 3	---		2911266.YO	5,5k	---		---		---	
PGO	GMAX 150 4T LC (GY6)	2912480.WO	4k	2916464.YO	5,5k	2916465.RO	5,5k	---		---	
	TIGRA 150 4T LC (GY6)	2912480.WO	4k	2916464.YO	5,5k	2916465.RO	5,5k	---		---	
PIAGGIO	BEVERLY 125 4T LC <-2009	2911478.WO	6,2k	2916459.YO	6,8k	2916460.RO	7,5k	---		---	
	BEVERLY 125 ie 4T LC euro 3 2010-> (QUASAR)	2911478.WO	6,2k	2916459.YO	6,8k	2916460.RO	7,5k	---		---	
	BEVERLY 200 4T LC	2911478.WO	6,2k	2916459.YO	6,8k	2916460.RO	7,5k	---		---	
	BEVERLY 250 4T LC euro 1-2 (M285M)	2911478.WO	6,2k	2916459.YO	6,8k	2916460.RO	7,5k	---		---	
	BEVERLY 250 ie 4T LC euro 3	2911478.WO	6,2k	2916459.YO	6,8k	2916460.RO	7,5k	---		---	
	BEVERLY 300 ie 4T LC euro 3	2911478.WO	6,2k	2916459.YO	6,8k	2916460.RO	7,5k	---		---	
	BEVERLY 400 ie 4T LC euro 3 (M345M)	2913003.WO	8,9k	2916507.YO	7,3k	2916508.RO	7,3k	---		---	
	BEVERLY 500 ie 4T LC euro 2-3	2913003.WO	8,9k	2916507.YO	7,3k	2916508.RO	7,3k	---		---	
	BEVERLY CRUISER 500 ie 4T LC euro 3	2913003.WO	8,9k	2916507.YO	7,3k	2916508.RO	7,3k	---		---	
	BEVERLY S 250 ie 4T LC euro 3	2911478.WO	6,2k	2916459.YO	6,8k	2916460.RO	7,5k	---		---	
	BEVERLY Sport Touring 350 ie 4T LC euro 3 (M693M)	2915315.WO	14,5k	---		---		---		---	
	BEVERLY TOURER 300 ie 4T LC euro 3	2911478.WO	6,2k	2916459.YO	6,8k	2916460.RO	7,5k	---		---	
	BEVERLY TOURER 400 ie 4T LC euro 3 (M345M)	2913003.WO	8,9k	2916507.YO	7,3k	2916508.RO	7,3k	---		---	
	CARNABY 125 4T LC euro 3 (LEADER M28FM)	2911478.WO	6,2k	2916459.YO	6,8k	2916460.RO	7,5k	---		---	
	CARNABY 200 4T LC euro 3 (LEADER M601M)	2911478.WO	6,2k	2916459.YO	6,8k	2916460.RO	7,5k	---		---	
	CARNABY 300 ie 4T LC euro 3 (QUASAR)	2911478.WO	6,2k	2916459.YO	6,8k	2916460.RO	7,5k	---		---	
	FLY 125 - 150 4T euro 2-3 (LEADER M422M)	2911478.WO	6,2k	2916459.YO	6,8k	2916460.RO	7,5k	---		---	
	HEXAGON 125 2T LC	2911478.WO	6,2k	2916459.YO	6,8k	2916460.RO	7,5k	---		---	
		2911084.WO	4,3k	---		---		---		---	
	HEXAGON 150 2T LC	2911478.WO	6,2k	2916459.YO	6,8k	2916460.RO	7,5k	---		---	
		2911084.WO	4,3k	---		---		---		---	
	HEXAGON LX 125 2T LC	2911478.WO	6,2k	2916459.YO	6,8k	2916460.RO	7,5k	---		---	
		2911084.WO	4,3k	---		---		---		---	
	HEXAGON LXT 180 2T LC	2911478.WO	6,2k	2916459.YO	6,8k	2916460.RO	7,5k	---		---	
		2911084.WO	4,3k	---		---		---		---	
	LIBERTY - LIBERTY LE 125 - 150 4T euro 1-2 (LEADER)	2911478.WO	6,2k	2916459.YO	6,8k	2916460.RO	7,5k	---		---	
	LIBERTY 125 - 150 4T euro 3 (LEADER)	2911478.WO	6,2k	2916459.YO	6,8k	2916460.RO	7,5k	---		---	
	LIBERTY - LIBERTY S 200 4T euro 3 (LEADER)	2911478.WO	6,2k	2916459.YO	6,8k	2916460.RO	7,5k	---		---	
	LIBERTY 3V 125 ie 4T euro 3	29 8360.WO	3,3k	---		29 7046.RO	4,7k	---		---	
	LIBERTY 3V 150 ie 4T euro 3 (M738M)	2912480.WO	4k	2916464.YO	5,5k	2916465.RO	5,5k	---		---	
	LIBERTY S 125 4T euro 3 (LEADER M381M)	2911478.WO	6,2k	2916459.YO	6,8k	2916460.RO	7,5k	---		---	
	MP3 125 4T LC euro 3 (LEADER)	2911478.WO	6,2k	2916459.YO	6,8k	2916460.RO	7,5k	---		---	
	MP3 250 ie 4T LC euro 3 (QUASAR M472M)	2911478.WO	6,2k	2916459.YO	6,8k	2916460.RO	7,5k	---		---	
	MP3 300 ie 4T LC euro 3 (QUASAR M634M)	2911478.WO	6,2k	2916459.YO	6,8k	2916460.RO	7,5k	---		---	
	MP3 300 ie 4T LC euro 3 2014-> (M862M)	2911478.WO	6,2k	2916459.YO	6,8k	2916460.RO	7,5k	---		---	
	MP3 400 ie 4T LC euro 3 (MASTER M474M)	2913003.WO	8,9k	2916507.YO	7,3k	2916508.RO	7,3k	---		---	
	MP3 500 ie 4T LC euro 3	2913003.WO	8,9k	2916507.YO	7,3k	2916508.RO	7,3k	---		---	
	MP3 YOURBAN 4V 125 ie 4T LC euro 3 2011->	2911478.WO	6,2k	2916459.YO	6,8k	2916460.RO	7,5k	---		---	
	MP3 YOURBAN 4V 300 ie 4T LC euro 3 2011->	2911478.WO	6,2k	2916459.YO	6,8k	2916460.RO	7,5k	---		---	

New



MAXISCOOTER			(K)		(K)		(K)		(K)		(K)
NEW FLY 3V 125 ie 4T euro 3 2012->	2912480.WO	4k	2916464.YO	5,5k	2916465.RO	5,5k	---	---	---	---	---
SKIPPER 125 2T	2911478.WO	6,2k	2916459.YO	6,8k	2916460.RO	7,5k	---	---	---	---	---
	2911084.WO	4,3k	---	---	---	---	---	---	---	---	---
SKIPPER 150 2T	2911478.WO	6,2k	2916459.YO	6,8k	2916460.RO	7,5k	---	---	---	---	---
	2911084.WO	4,3k	---	---	---	---	---	---	---	---	---
SKIPPER LX 125 2T	2911478.WO	6,2k	2916459.YO	6,8k	2916460.RO	7,5k	---	---	---	---	---
	2911084.WO	4,3k	---	---	---	---	---	---	---	---	---
SKIPPER LXT 150 2T	2911478.WO	6,2k	2916459.YO	6,8k	2916460.RO	7,5k	---	---	---	---	---
	2911084.WO	4,3k	---	---	---	---	---	---	---	---	---
SKIPPER ST 125 - 150 4T (LEADER)	2911478.WO	6,2k	2916459.YO	6,8k	2916460.RO	7,5k	---	---	---	---	---
SUPER HEXAGON GTX 125 4T LC	2911478.WO	6,2k	2916459.YO	6,8k	2916460.RO	7,5k	---	---	---	---	---
SUPER HEXAGON GTX 180 4T LC	2911478.WO	6,2k	2916459.YO	6,8k	2916460.RO	7,5k	---	---	---	---	---
TYPHOON 125 4T euro 3 (LEADER M701M)	2911478.WO	6,2k	2916459.YO	6,8k	2916460.RO	7,5k	---	---	---	---	---
X7 125 4T LC euro 3 (LEADER)	2911478.WO	6,2k	2916459.YO	6,8k	2916460.RO	7,5k	---	---	---	---	---
X7 250 ie 4T LC euro 3 (QUASAR M622M)	2911478.WO	6,2k	2916459.YO	6,8k	2916460.RO	7,5k	---	---	---	---	---
X7 EVO 125 ie 4T LC euro 3 (QUASAR)	2911478.WO	6,2k	2916459.YO	6,8k	2916460.RO	7,5k	---	---	---	---	---
X7 EVO 300 ie 4T LC euro 3 (QUASAR)	2911478.WO	6,2k	2916459.YO	6,8k	2916460.RO	7,5k	---	---	---	---	---
X8 125 4T LC euro 2-3 (LEADER)	2911478.WO	6,2k	2916459.YO	6,8k	2916460.RO	7,5k	---	---	---	---	---
X8 200 4T LC	2911478.WO	6,2k	2916459.YO	6,8k	2916460.RO	7,5k	---	---	---	---	---
X8 250 4T LC euro 2	2911478.WO	6,2k	2916459.YO	6,8k	2916460.RO	7,5k	---	---	---	---	---
X8 250 ie 4T LC euro 3 (QUASAR)	2911478.WO	6,2k	2916459.YO	6,8k	2916460.RO	7,5k	---	---	---	---	---
X8 400 ie 4T LC euro 3 (M521M)	2913003.WO	8,9k	2916507.YO	7,3k	2916508.RO	7,3k	---	---	---	---	---
X9 200 4T LC	2911478.WO	6,2k	2916459.YO	6,8k	2916460.RO	7,5k	---	---	---	---	---
X9 250 4T LC (HONDA)	2911072.WO	9,9k	2911074.YO	3,6k	---	---	---	---	---	---	---
X9 4V 125 4T LC	2911478.WO	6,2k	2916459.YO	6,8k	2916460.RO	7,5k	---	---	---	---	---
X9 4V Evolution 125 4T LC euro 2-3	2911478.WO	6,2k	2916459.YO	6,8k	2916460.RO	7,5k	---	---	---	---	---
X9 AMALFI 180 4T LC	2911478.WO	6,2k	2916459.YO	6,8k	2916460.RO	7,5k	---	---	---	---	---
X9 Evolution 250 4T LC (M237M)	2911478.WO	6,2k	2916459.YO	6,8k	2916460.RO	7,5k	---	---	---	---	---
X9 Evolution - Street 500 4T LC	2913003.WO	8,9k	2916507.YO	7,3k	2916508.RO	7,3k	---	---	---	---	---
X10 125 ie 4T LC euro 3	2911478.WO	6,2k	2916459.YO	6,8k	2916460.RO	7,5k	---	---	---	---	---
X10 350 ie 4T LC euro 3 (M762M)	2915315.WO	14,5k	---	---	---	---	---	---	---	---	---
X10 500 ie 4T LC euro 3	2913003.WO	8,9k	2916507.YO	7,3k	2916508.RO	7,3k	---	---	---	---	---
XEvo 125 4T LC euro 3 (LEADER)	2911478.WO	6,2k	2916459.YO	6,8k	2916460.RO	7,5k	---	---	---	---	---
XEvo 250 ie 4T LC euro 3 (QUASAR)	2911478.WO	6,2k	2916459.YO	6,8k	2916460.RO	7,5k	---	---	---	---	---
XEvo 400 ie 4T LC euro 3 (M521M)	2913003.WO	8,9k	2916507.YO	7,3k	2916508.RO	7,3k	---	---	---	---	---
ZIP 125 4T (LEADER)	2911478.WO	6,2k	2916459.YO	6,8k	2916460.RO	7,5k	---	---	---	---	---
RENAULT FULLTIME 125 4T (LEADER)	2911478.WO	6,2k	2916459.YO	6,8k	2916460.RO	7,5k	---	---	---	---	---
SUZUKI BURGMAN AN - Business 400 4T LC	---	---	2911429.YO	6k	---	---	---	---	---	---	---
BURGMAN AN 400 ie 4T LC <-2007 (K429)	---	---	2911429.YO	6k	---	---	---	---	---	---	---
BURGMAN K 7 125 ie 4T LC euro 3 (F490)	2914203.WO	2,8k	---	---	---	---	---	---	---	---	---
BURGMAN AN K 7 > K 9 400 ie 4T LC	---	---	2911429.YO	6k	---	---	---	---	---	---	---
BURGMAN AN K10 > 400 ie 4T LC	2916114.WO	7,7k	---	---	---	---	---	---	---	---	---
BURGMAN UH 125 - 150 4T LC	2914203.WO	2,8k	---	---	---	---	---	---	---	---	---
BURGMAN UH 200 ie 4T LC euro 3	---	---	2912647.YO	4,5k	---	---	---	---	---	---	---
EPICURO 125 -150 4T LC	2914203.WO	2,8k	---	---	---	---	---	---	---	---	---
SIXTEEN 125 - 150 4T LC euro 3	2914203.WO	2,8k	---	---	---	---	---	---	---	---	---
SYM CITYCOM 300 4T LC euro 3 (LEA 1)	---	---	2911074.YO	3,6k	---	---	---	---	---	---	---
EURO MX 125 4T	---	---	2911266.YO	5,5k	---	---	---	---	---	---	---
FIDDLE 2 125 4T euro 3	2912480.WO	4k	2916464.YO	5,5k	2916465.RO	5,5k	---	---	---	---	---
FIDDLE III W4 125 4T euro 3 (XS1P52QMI-3B)	---	---	2911266.YO	5,5k	---	---	---	---	---	---	---
GTS 125 4T LC euro 3	---	---	2911266.YO	5,5k	---	---	---	---	---	---	---
GTS I 250 ie 4T LC euro 3	---	---	2911074.YO	3,6k	---	---	---	---	---	---	---
GTS Evo I 300 ie 4T LC euro 3 (MK8)	---	---	2911074.YO	3,6k	---	---	---	---	---	---	---
HD Evo I 125 ie 4T LC euro 3	---	---	2911266.YO	5,5k	---	---	---	---	---	---	---
JOYMAX I 250 ie 4T LC euro 3 (HMA-1)	---	---	2911074.YO	3,6k	---	---	---	---	---	---	---
JOYMAX I 300 ie 4T LC euro 3 (MK915096)	---	---	2911074.YO	3,6k	---	---	---	---	---	---	---
JOYMAX Evo I 300 ie 4T LC euro 3 (MK8)	---	---	2911074.YO	3,6k	---	---	---	---	---	---	---
SUPER Duke 150 4T	---	---	2911266.YO	5,5k	---	---	---	---	---	---	---
PHONY S 125 4T euro 3 (XS1P52QMI-4)	---	---	2911266.YO	5,5k	---	---	---	---	---	---	---

MAXISCOOTER			(K)		(K)		(K)		(K)		(K)
TGB	X MOTION 250 4T LC	---		2911074.YO	3,6k	---		---		---	
VESPA	946 3V ABS 125 ie 4T (M801M)	2912480.WO	4k	2916464.YO	5,5k	2916465.RO	5,5k	---		---	
	ET4 125 - 150 4T (LEADER)	2911478.WO	6,2k	2916459.YO	6,8k	2916460.RO	7,5k	---		---	
	Granturismo L - GT 125 4T LC (LEADER)	2911478.WO	6,2k	2916459.YO	6,8k	2916460.RO	7,5k	---		---	
	Granturismo L - GT 200 4T LC (M312M)	2911478.WO	6,2k	2916459.YO	6,8k	2916460.RO	7,5k	---		---	
	GTS 125 4T LC euro 3 (M315M)	2911478.WO	6,2k	2916459.YO	6,8k	2916460.RO	7,5k	---		---	
	GTS 250 ie 4T LC	2911478.WO	6,2k	2916459.YO	6,8k	2916460.RO	7,5k	---		---	
	GTS Super 125 ie 4T LC euro 3	2911478.WO	6,2k	2916459.YO	6,8k	2916460.RO	7,5k	---		---	
	GTS Super 300 ie 4T LC euro 3	2911478.WO	6,2k	2916459.YO	6,8k	2916460.RO	7,5k	---		---	
	GTV 125 4T LC (LEADER)	2911478.WO	6,2k	2916459.YO	6,8k	2916460.RO	7,5k	---		---	
	GTV 250 ie 4T LC	2911478.WO	6,2k	2916459.YO	6,8k	2916460.RO	7,5k	---		---	
	GTV 300 ie 4T LC euro 3 (QUASAR)	2911478.WO	6,2k	2916459.YO	6,8k	2916460.RO	7,5k	---		---	
	LX 125 - 150 4T (LEADER)	2911478.WO	6,2k	2916459.YO	6,8k	2916460.RO	7,5k	---		---	
	LX 125 - 150 ie 4T euro 3 (LEADER)	2911478.WO	6,2k	2916459.YO	6,8k	2916460.RO	7,5k	---		---	
	LX 3V 125 - 150 ie 4T euro 3 2012->	2912480.WO	4k	2916464.YO	5,5k	2916465.RO	5,5k	---		---	
	LXV 125 ie 4T euro 3 (LEADER)	2911478.WO	6,2k	2916459.YO	6,8k	2916460.RO	7,5k	---		---	
	Primavera 3V 125 ie 4T euro 3 2014-> (M811M)	29 8360.WO	3,3k	---			29 7046.RO	4,7k	---		---
	Primavera 3V 150 ie 4T euro 3 2014-> (M812M)	2912480.WO	4k	2916464.YO	5,5k	2916465.RO	5,5k	---		---	
	S 125 - 150 4T euro 3 (LEADER)	2911478.WO	6,2k	2916459.YO	6,8k	2916460.RO	7,5k	---		---	
	S 3V 125 ie 4T euro 3 2012->	2912480.WO	4k	2916464.YO	5,5k	2916465.RO	5,5k	---		---	
	Sprint 3V 125 - 150 ie 4T euro 3 2014->	29 8360.WO	3,3k	---			29 7046.RO	4,7k	---		---
WT MOTORS	ATENE 152 4T LC (1P58MJA)	2912480.WO	4k	2916464.YO	5,5k	2916465.RO	5,5k	---		---	
YAMAHA	BW'S 125 ie 4T euro 3 (E3G3E)	---		2912647.YO	4,5k	---		---		---	
	CYGNUS 125 4T	---		2912647.YO	4,5k	---		---		---	
	CYGNUS X 125 4T	---		2912647.YO	4,5k	---		---		---	
	CYGNUS X 125 ie 4T euro 3	---		2912647.YO	4,5k	---		---		---	
	D'ELIGHT 115 4T euro 3 (E3M5E)	---		---		29 7046.RO	4,7k	---		---	
	MAJESTY 125 - 150 4T LC	---		2912647.YO	4,5k	---		---		---	
	MAJESTY 180 4T LC	---		2912647.YO	4,5k	---		---		---	
	MAJESTY 250 4T LC	---		29 9975.YO	7,8k	29 9976.RO	9k	---		---	
	MAJESTY 400 4T LC <-2008 (H317E)	2914120.WO	10,3k	---		---		---		---	
	MAJESTY 400 4T LC euro 3 2009-> (H322E)	2914120.WO	10,3k	---		---		---		---	
	MAJESTY S 125 ie 4T LC	2915464.WO	9,5k	---		---		---		---	
	MAXSTER 125 - 150 4T LC	---		2912647.YO	4,5k	---		---		---	
	SMax 125 - 160 ie 4T LC	2915464.WO	9,5k	---		---		---		---	
	T MAX (carb.) 500 4T LC 2001->2003	2912772.WO	11,9k	2914024.YO	9,7k	2914023.RO	13,7k	2914401.GO	6,8k	---	
	T MAX 500 ie 4T LC 2004->2011	2912772.WO	11,9k	2914024.YO	9,7k	2914023.RO	13,7k	2914401.GO	6,8k	---	
	T MAX 530 ie 4T LC 2012->	2912772.WO	11,9k	2914024.YO	9,7k	2914023.RO	13,7k	2914401.GO	6,8k	---	
	TEO'S 125 - 150 4T LC	---		2912647.YO	4,5k	---		---		---	
	VERSITY XC 300 4T LC (H314E)	---		29 9975.YO	7,8k	---		---		---	
	X CITY 125 ie 4T LC euro 3 (E3A5E)	---		2912647.YO	4,5k	---		---		---	
	X CITY 250 ie 4T LC euro 3 (G358E)	---		29 9975.YO	7,8k	---		---		---	
	X CITY 250 ie 4T LC euro 3 2014-> (G3B7E)	---		29 9975.YO	7,8k	---		---		---	
	X MAX 125 ie 4T LC euro 3	---		2912647.YO	4,5k	---		---		---	
	X MAX 250 4T LC	---		29 9975.YO	7,8k	---		---		---	
	X MAX 250 ie 4T LC euro 3 2008->	---		29 9975.YO	7,8k	---		---		---	
	X MAX 400 ie 4T LC euro 3 (H330E)	2914120.WO	10,3k	---		---		---		---	
	Xenter 125 - 150 ie 4T LC	2915464.WO	9,5k	---		---		---		---	
	ZUMA 125 ie 4T euro 3	---		2912647.YO	4,5k	---		---		---	
ATV - QUAD											
ACCESS	SPORT 300 4T LC	2914712.WO	9,9k	---		---		---		---	
AEON MOTOR	COBRA S 272 4T LC (V55C)	---		2911074.YO	3,6k	---		---		---	
	COBRA 400 4T LC (V69C)	---		2911074.YO	3,6k	---		---		---	
	CROSSLAND 300 4T LC	2914712.WO	9,9k	---		---		---		---	
AIE	MAGMAX 275 4T LC (FBGM)	---		2911074.YO	3,6k	---		---		---	
KYMCO	KXR SPORT - MXU 250 4T LC	2914712.WO	9,9k	---		---		---		---	
	MAXXER 300 4T LC	2914712.WO	9,9k	---		---		---		---	
PGO	BUG RACER 500 4T LC (PIAGGIO)	2913003.WO	8,9k	2916507.YO	7,3k	2916508.RO	7,3k	---		---	
WT MOTORS	KAYMAN WT 150 4T (1P57QMJ)	---		2911266.YO	5,5k	---		---		---	

New



SPECIAL X BELT

Technical features:
 1 POLYAMIDE FABRIC
 2 CHLOROPRENE RUBBER-COATED FABRIC
 3 CHLOROPRENE BEARING
 4 **POLYESTERE ELEMENT**
 5 COMPOUND OF CHLOROPRENE ELEMENT LOADED WITH FIBERS

Tourist – Sport use



X Special Belt

X Special trapezoidal belts are the best choice to ensure maximum performance and reliability from your scooter.

They are produced with special mixtures to guarantee optimal resistance and drive; their forms have been developed to perfectly fit the surface of the automatic transmission elements.

X Special Belt is not only perfectly compatible with the original belt, but it offers all the advantages of a Malossi high-quality product.

KX BELT

Technical features:
 1 POLYAMIDE FABRIC
 2 CHLOROPRENE RUBBER-COATED FABRIC
 3 CHLOROPRENE BEARING
 4 **KEVLAR® ELEMENT**
 5 COMPOUND OF CHLOROPRENE ELEMENT LOADED WITH FIBERS

Sport – Racing use



X K Belt

Malossi X K Belt is the top of racing transmission belts!

Made with hard-wearing materials combined with Kevlar® inserts, Malossi trapezoidal X K belts provide a very high thermal and abrasion resistance. Worthy exponents of MALOSSSI HYPER RACING product range, they are the result of decades of experience and of search for absolute performance in the racing field.

DuPont™ and Kevlar® are trademarks or registered trademarks of E.I. du Pont de Nemours and Company.

Products to be used exclusively for racing in places specially designed for such activity according to the regulations of the competent sporting authorities. We accept no liability resulting from improper use.

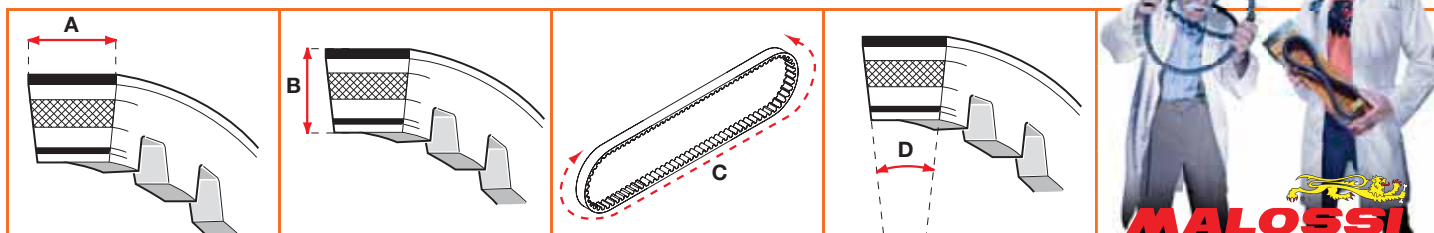

BELTS - Technical specifications in order of width

Width mm (A)	Thickness mm (B)	External size mm (C)	Angle (D)	CODE	Price €	MODEL	APPLICATIONS
10	8	927	36°	61 7224	10.96	X SPECIAL BELT	PIAGGIO 50 2T CIAO - CIAO PX
		940	36°	61 7226	9.93		
13	6,5	974	30°	6116830	27.50	X K BELT	PIAGGIO 50 2T CIAO - CIAO PX
13	6,5	978	34°	61 7227	11.70	X SPECIAL BELT	PIAGGIO 50 2T CIAO - CIAO PX
13	6,5	1089	34°	61 7222	12.60	X SPECIAL BELT	PIAGGIO 50 2T GRILLO
13	6,5	1143	34°	61 7314	17.50	X SPECIAL BELT	PIAGGIO 50 2T BOSS - SI
13	6,5	1056	30°	6117005	29.50	X K BELT	PIAGGIO 50 2T BRAVO - SUPERBRAVO
13	6,5	1134	30°	6117006	31.00	X K BELT	PIAGGIO 50 2T BOSS - SI
13	8	870	38°	61 7219	12.90	X SPECIAL BELT	PEUGEOT 50 2T ADVENGER - HOLLYWOOD - 103 SP [104 - 105] - XP LC - XP
13,4	6,5	1060	34°	61 7223	13.16	X SPECIAL BELT	PIAGGIO 50 2T BRAVO - SUPERBRAVO
14,5	8	819	30°	6112745	15.81	X SPECIAL BELT	MBK 50 2T 51 V / MAGNUM / PASSION / RACING (AV 10) - ROCK
15	8	747	30°	61 7220	12.90	X SPECIAL BELT	PEUGEOT 50 2T 103 RCX - 103 SPX
15	8	793	30°	61 7216	14.80	X SPECIAL BELT	GARELLI 50 2T PONY
							ITALJET 50 2T BAZOOKA - PISTA - REPORTER
							MBK 50 2T ACTIVE - SORRISO <-1995
							YAMAHA 50 2T BELUGA - CT
15	8	853	32°	61 7233	12.90	X SPECIAL BELT	HONDA 50 2T SH <-1995
15,3	8	642	32°	61 7213	13.94	X SPECIAL BELT	HONDA 50 2T VISION - VISION MET IN PEUGEOT 50 2T RAPIDO - ST
15,3	8	652	32°	61 7215	23.50	X K BELT	BSV 50 2T DIO SP - DIO SR
							HONDA 50 2T DIO SP - DIO SR
							HSC 50 2T SC 01
16	8	828	26°	6111152	28.25	X K BELT	CAGIVA 50 2T PROGRESS
		832		6111164	18.68	X SPECIAL BELT	DERBI 50 2T ATLANTIS <-2002 - ATLANTIS LC - HUNTER - PADDOCK - PADDOCK LC - PREDATOR - PREDATOR LC
16	8	1180	32°	61 7214	22.47	X SPECIAL BELT	HONDA 50 2T WALLAROO PEUGEOT 50 2T FOX
16,5	8	670	30°	61 7231	23.22	X K BELT	ITALJET 50 2T TORPEDO - VELOCIFERO
							RIZZATO 50 2T VAMOS
							SUZUKI 50 2T ADDRESS AH - AP - SEPIA - SEPIA ZZ
16,5	8	703	30°	61 7664	18.60	X K BELT	CAGIVA 50 2T CITY
16,5	8	745	30°	6112729	25.23	X K BELT	APRILIA 50 2T AMICO - AREA 51 LC - GULLIVER - GULLIVER LC - RALLY (MINARELLI) - RALLY LC (MINARELLI) - SCARABEO - SR - SR NETSCAPER LC (MINARELLI) - SR RACING LC (MINARELLI) - SR REPLICA LC <-1999 - SR STEALTH LC (MINARELLI) - SR WWW
				6112730	14.36	X SPECIAL BELT	ATALA 50 2T CAROSELLO BENELLI 50 2T 491 GT (MINARELLI) - 491 SPORT LC (MINARELLI) K2 - K2 LC - NAKED - PEPE BETA 50 2T ARK - ARK LC - CHRONO - EIKON LC - QUADRA - TEMPO ITALJET 50 2T DRAGSTER LC - PISTA 2 - SCOOP - YANKEE MALAGUTI 50 2T CENTRO - CIAK - F12-PHANTOM - F12-PHANTOM LC - F12 DIGIT KAT-PHANTOM LC / LC euro 2 - F12 R LC LC euro 2 - F15 FIREFOX LC MBK 50 2T BOOSTER euro 0-1 - BOOSTER euro 2 (A137E) - BOOSTER NAKED euro 2 (A137E) - BOOSTER NG euro 0-1 - BOOSTER NG euro 2 (A137E) - BOOSTER ROCKET euro 0-1 - BOOSTER ROCKET euro 2 (A137E) - BOOSTER SPIRIT euro 0-1 - BOOSTER SPIRIT euro 0-1 - FLIPPER - MACH G - MACH G LC - NITRO LC - OVETTO - STUNT euro 0-1 - STUNT euro 2 YAMAHA 50 2T AEROX LC euro 0-1 - AEROX LC euro 2 - BW'S euro 0-1 - BW'S euro 2 (A137E) - BW'S NG euro 0-1 - BW'S NG euro 2 (A137E) - BW'S Original/Naked euro 2 2010-> (A137E) - JOG R - JOGRR LC euro 2 - NEO'S - SLIDER - SPY - WHY - ZUMA

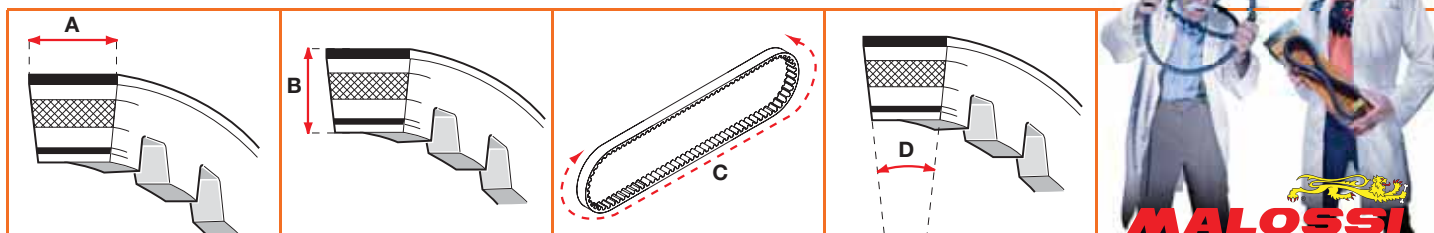

BELTS - Technical specifications in order of width

Width mm (A)	Thickness mm (B)	External size mm (C)	Angle (D)	CODE	Price €	MODEL	APPLICATIONS														
16,5	8	796	28°	6112742	26.33	X K BELT	AEON MOTOR 50 2T COBRA (AT70) APRILIA 50 2T SONIC - SONIC LC DINLI 50 2T HELIX DL603 (06A53) - HELIX DL603 90 2T (06B93) - T.REX DRR 90 2T DRX E-TON 50 2T VIPER RXL - VIPER RXL 90 2T LAVERDA 50 2T QUASAR (AR 03) MALAGUTI 50 2T F10 - YESTERDAY MBK 50 2T BOOSTER X ie 4T LC euro 2 - EVOLIS - FIZZ - FORTE - SORRISO 1996-> - TARGET YAMAHA 50 2T AEROX 4 ie 4T LC euro 2 - AXIS - BREEZE - C3 [XF] ie 4T LC euro 2 (A311E) - CRZ - GIGGLE [XF] ie 4T LC euro 2 (A311E) - JOG - JOG ER - NEO'S ie 4T LC euro 2 (A316E) - VINO - VOX [XF] ie 4T LC euro 2 (A311E) - ZEST - ZUMA FX ie 4T LC														
			30°	6112741	18,61	X SPECIAL BELT															
16,8	9,5	814	30°	61 8780	18.68	X SPECIAL BELT	ATALA 50 2T HACKER - HACKER LC ITALJET 50 2T FORMULA (F.MORINI) - FORMULA LC (F.MORINI) MALAGUTI 50 2T CROSSER CR1														
17	8	735	30°	61 7229	20.24	X K BELT	PIAGGIO 50 2T SFERA - SFERA 75 - ZIP <-1999														
17	8	781	30°	61 9591	25.17	X K BELT	SUZUKI 50 2T KATANA - KATANA LC <-1998														
17	8	802	30°	61 9832	17.04	X SPECIAL BELT	BENELLI 50 2T PEPE LX euro 2 (QJ1E40QMB-4) - QuattronoveX euro 2 CPI 50 2T ARAGON GP - HUSSAR 2003-> - OLIVER 2003-> - POPCORN 2003-> EXPLORER 50 2T CRACKER 2003-> (GE 1E 400 MB) GARELLI 50 2T GSP LC euro 2 (1PE40MB) - TIESSE 50R euro 2 (1E40QMB) - VIP 4T (139 QMA) GILERA 50 2T STORM - TYPHOON HUPPER 50 2T MONTECARLO 30 (1E40QMB) KEEWAY 50 2T F-ACT - GOCCIA (KW1E40QMB-4) - HURRICANE euro 2 (KW1E40QMB) - MATRIX (KW1E40QMB-4) - PIXEL euro 2 (KW1E40QMB) - RY8 (KW1E40QMB-4) MALAGUTI 50 2T F10 WAP euro 2 (QJ*CMA03C*) OVER 50 2T F12 R ARIA euro 2 (QJ*CMA02C*) PIAGGIO 50 2T B3 4T LC (LJ1P38MB) - THOR LC 2013-> (LJ1PE40MB) PIAGGIO 50 2T FREE <-2000 - NRG LC - NRG MC2 LC <-1997 - NTT LC														
							17,5	8	724	30°	61 7665	25.68	X K BELT	GILERA 50 2T EASY MOVING PIAGGIO 50 2T QUARTZ LC - SFERA RESTYLING - ZIP Fast Rider - ZIP SP LC <-2000 VESPA 50 2T ET2 <-1999							
									723		61 9829	20.63	X SPECIAL BELT								
							17,5	8	804	30°	61 7587	28.25	X K BELT	BENELLI 50 2T PEPE LX euro 2 (QJ1E40QMB-4) - QuattronoveX euro 2 CPI 50 2T ARAGON GP - HUSSAR 2003-> - OLIVER 2003-> - POPCORN 2003-> EXPLORER 50 2T CRACKER 2003-> (GE 1E 400 MB) GARELLI 50 2T TIESSE 50R euro 2 (1E40QMB) - VIP 4T (139 QMA) GILERA 50 2T STORM - TYPHOON HUPPER 50 2T MONTECARLO 30 (1E40QMB) KEEWAY 50 2T F-ACT - GOCCIA (KW1E40QMB-4) - HURRICANE euro 2 (KW1E40QMB) - MATRIX (KW1E40QMB-4) - PIXEL euro 2 (KW1E40QMB) - RY8 (KW1E40QMB-4) MALAGUTI 50 2T F10 WAP euro 2 (QJ*CMA03C*) OVER 50 2T F12 R ARIA euro 2 (QJ*CMA02C*) PIAGGIO 50 2T B3 4T LC (LJ1P38MB) - THOR LC 2013-> (LJ1PE40MB) PIAGGIO 50 2T FREE <-2000 - NRG LC - NRG MC2 LC <-1997 - NTT LC							
														17,5	8	815	30°	6111108	27.80	X K BELT	APRILIA 50 2T SONIC - SONIC LC MALAGUTI 50 2T F10 - YESTERDAY MBK 50 2T EVOLIS - FIZZ - FORTE - HOT CHAMP PEUGEOT 50 2T LOOXOR TSDI YAMAHA 50 2T AXIS - BREEZE - JOG ER - JOG - JOG Z - VINO - ZEST

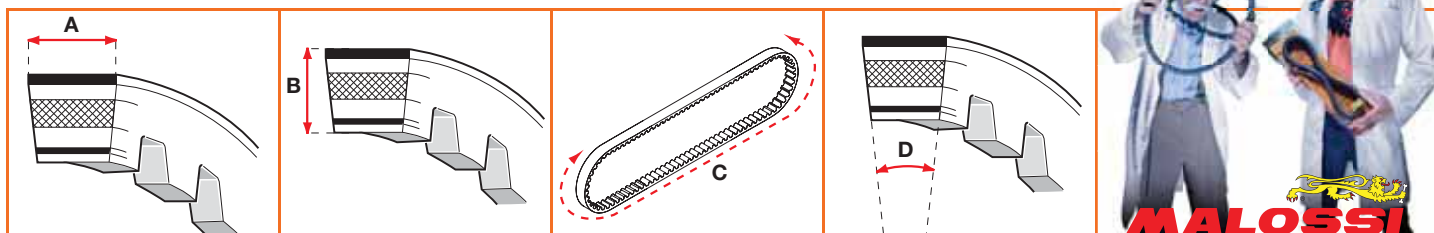

BELTS - Technical specifications in order of width

Width mm (A)	Thickness mm (B)	External size mm (C)	Angle (D)	CODE	Price €	MODEL	APPLICATIONS
17,5	9	675	32°	61 7211	25.68	X K BELT	BSV 50 2T DIO GP - DIO ZX HONDA 50 2T DIO G - DIO ZX HSC 50 2T SC 01 L KYMCO 50 2T CX - DJ X - DJ Y SYM 50 2T DD
17,5	9,5	820	30°	61 8779	31.05	X K BELT	ATALA 50 2T HACKER - HACKER LC ITALJET 50 2T FORMULA (F.MORINI) - FORMULA LC (F.MORINI) MALAGUTI 50 2T CIAK 100 2T - CROSSER CR1 - F12-PHANTOM 100 2T
17,8	10	778	28°	6112959	28.51	X K BELT	APRILIA 100 2T SCARABEO BENELLI 100 2T K2 ITALJET 100 2T MILLENNIUM MBK 100 2T BOOSTER - NITRO - OVETTO YAMAHA 100 2T AEROX - BW'S - NEO'S
18	8	705	32°	61 7221	24.41	X K BELT	HONDA 50 2T BALI - SFX - SHADOW - SXR PEUGEOT 50 2T SV GEO - ZENITH
		703		61 8396	14.68	X SPECIAL BELT	
18	8	769	32°	6112736	27.23	X K BELT	PEUGEOT 50 2T BUXY - BUXY RS - ELYSEO - JET FORCE C-TECH LC - JET FORCE TSDI LC (HL 1) - LOOXOR - LUDIX - LUDIX BLASTER LC (HL 2) - METAL-X - SPEEDAKE - SPEEDFIGHT - SPEEDFIGHT LC - SPEEDFIGHT 2 LC 2004-> SPEEDFIGHT 3 (B1E 40 QMB) - SPEEDFIGHT 3 LC - SPEEDFIGHT 3 4T (XS1P37QMA-2) - SQUAB - TREKKER - TWEET 4T euro 2 - TWEET ² RS 4T euro 2 - VIVACITY - VIVACITY COMPACT (FB2FP) X-FIGHT - X-FIGHT LC - X-FIGHT 2 LC 2004->
				6112735	15.46	X SPECIAL BELT	
18	8	798	30°	6117248	24.00	X SPECIAL BELT	HONDA 50 4T RUCKUS LC - ZOOMER LC
18	8	818	30°	6113191	25.34	X K BELT	APRILIA 50 4T SCARABEO (PIAGGIO C373M) - SCARABEO 100 4T - SCARABEO 4V euro 2 - SPORTCITY ONE (PIAGGIO C377M)
							ITALJET 50 4T TORPEDO
							MALAGUTI 50 4T CENTRO euro 2 (C432M) - CIAK MASTER euro 2
							PIAGGIO 50 4T FREE 100 4T - LIBERTY - LIBERTY 100 4T - LIBERTY 4V euro 2
18	8	835	32°	61 9463	28.02	X K BELT	HONDA 50 2T SH 1996-> - SGX SKY - X8R X - X8R S SYM 200 4T JOYRIDE Evo I ie LC (KB2)
		838		61 9221	18.68	X SPECIAL BELT	
18	9	743	30°	6113501	20.40	X K BELT	GARELLI 50 4T FLEXI' euro 2 (1P139 QMB) - TIESSE FOUR euro 2 (1P39QMB)
							HUPPER 50 4T MONTECARLO 30 (139QMB)
							KYMCO 50 4T AGILITY R10/12 - RS euro 2 (KL10B) - AGILITY R16 50 2T euro 2 (KF10B) - AGILITY R16 - RS euro 2 (KL10B) - DINK euro 2 - LIKE euro 2 (KG10A)
							PEOPLE euro 2 - PEOPLE S euro 2 (BB10) - SUPER 8 euro 2 (KL10) - VITALITY euro 2 (SG10)
							WT MOTORS 50 4T BILBAO (PEDA 139QMB)
18	9,5	680	30°	6113397	22.44	X K BELT	BAOTIAN 50 4T ECO BIKE (139 QMB)
							MALAGUTI 50 4T DVD (139 QMB)
							PEUGEOT 50 4T V-CLIC

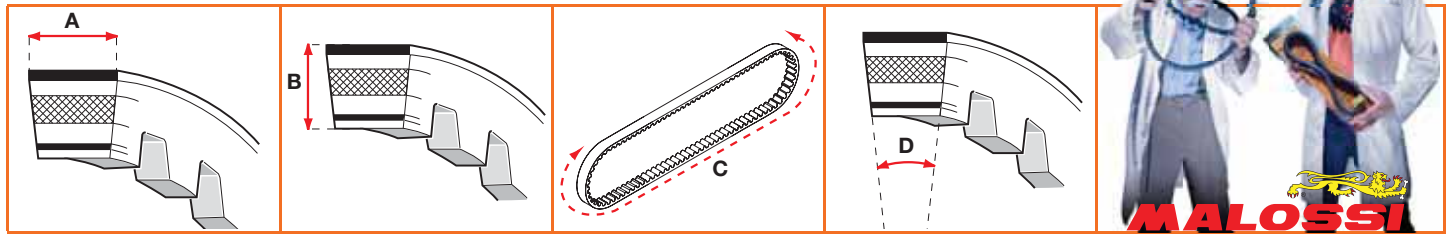

BELTS - Technical specifications in order of width

Width mm (A)	Thickness mm (B)	External size mm (C)	Angle (D)	CODE	Price €	MODEL	APPLICATIONS
18	10,2	782	28°	6115822	44.88	X K BELT	APRILIA 50 2T AMICO - AREA 51 LC - GULLIVER LC - RALLY (MINARELLI) - RALLY LC (MINARELLI) - SCARABEO (MINARELLI) - SR 1994-> - SR NETSCAPER LC (MINARELLI) - SR RACING LC (MINARELLI) - SR REPLICA LC <-1999 - SR STEALTH LC (MINARELLI) - SR WWW BENELLI 50 2T 491 GT (MINARELLI) - 491 SPORT LC (MINARELLI) - K2 - K2 LC - NAKED BETA 50 2T ARK - ARK LC - EIKON LC - QUADRA ITALJET 50 2T DRAGSTER LC MALAGUTI 50 2T F12-PHANTOM - F12-PHANTOM LC - F12 DIGIT KAT-PHANTOM LC / LC euro 2 - F12 R LC LC euro 2 - F15 FIREFOX LC MBK 50 2T BOOSTER euro 0-1 - BOOSTER euro 2 (A137E) - BOOSTER NAKED euro 2 (A137E) - BOOSTER NG euro 0-1 - BOOSTER NG euro 2 (A137E) - BOOSTER ROCKET euro 0-1 - BOOSTER ROCKET euro 2 (A137E) - BOOSTER SPIRIT euro 0-1 - FLIPPER - MACH G - MACH G LC - NITRO LC - OVETTO - STUNT euro 0-1 - STUNT euro 2 YAMAHA 50 2T AEROX LC euro 0-1 - AEROX LC euro 2 - BW'S euro 0-1 - BW'S euro 2 (A137E) - BW'S NG euro 0-1 - BW'S NG euro 2 (A137E) - BW'S Original/Naked euro 2 2010-> (A137E) - JOG R - JOGRR LC euro 2 - NEO'S - SLIDER - SPY - WHY - ZUMA
18,2	8	683	30°	6113503	22.00	X K BELT	KYMC0 50 4T FILLY - SENTO euro 2 KYMC0 50 2T HEROISM - Mxer - SNIPER
18,2	8	734	30°	6111153	28.25	X K BELT	KYMC0 50 2T DINK - DINK LC - PEOPLE - SUPER 9 LC - TOP BOY-COBRA VESPA 125 4T ET4
18,5	8	727	30°	6111246	18.50	X SPECIAL BELT	PIAGGIO 50 2T FLY 4T - ZIP 2000-> - ZIP SP LC 2001-> - ZIP 4T VESPA 50 2T ET2 2000-> - ET4 4T - LX - LX 4T - LX 4V 4T euro 2 - S euro 2 (C381M) - S 4V 4T euro 2 (C386M)
18,5	8	765	30°	6116424	21.00	X K BELT	VESPA 50 4T Primavera 4V euro 2 (C532M)
18,5	8	779	30°	6111294	28.38	X K BELT	APRILIA 50 2T HABANA - MOJITO - SCARABEO DITECH - SR DITECH LC (APRILIA) - SR REPLICA LC 2000-> (APRILIA)
		782		6111295	17.71	X SPECIAL BELT	SUZUKI 50 2T ESTILETE - UF - KATANA 1999-> - KATANA LC 1999-> - ZILLION LC SYM 50 4T SYMPHONY euro 2 (XS1P37QMA-2)
18,5	8	830	30°	61 9535	28.72	X K BELT	APRILIA 50 2T SCARABEO STREET (PIAGGIO) - SPORTCITY ONE STREET euro 2 DERBI 50 2T VARIANT Sport
		834		61 9830	17.34	X SPECIAL BELT	GILERA 50 2T DNA LC ITALJET 50 2T TORPEDO NEW PIAGGIO 50 2T LIBERTY - TYPHOON euro 2 2011-> (C421M)
18,5	8,5	794	30°	6116748	32.00	X SPECIAL BELT	HONDA 110 4T VISION ie (JF31E)
18,7	8	810	30°	6116889	18.50	X SPECIAL BELT	APRILIA 50 2T MOJITO CUSTOM - SCARABEO 4T (PIAGGIO C373M) - SCARABEO 4V 4T euro 2 - SPORTCITY ONE 4T (PIAGGIO C377M) - SR (carb.) LC 2004-> (PIAGGIO) - SR DITECH GP1 LC (PIAGGIO C361M) - SR MOTARD euro 2 - SR R (carb.) LC (PIAGGIO) - SR R FACTORY LC (PIAGGIO C361M) DERBI 50 2T ATLANTIS-BULLET 2003-> - GP1 LC - GP1 OPEN LC - GP1 REVOLUTION LC GILERA 50 2T ICE - RUNNER LC - RUNNER PureJet LC - RUNNER SP LC - STALKER - TYPHOON X ITALJET 50 2T JET SET - TORPEDO 4T MALAGUTI 50 2T CENTRO 4T euro 2 (C432M) - CIAK MASTER 4T euro 2 PIAGGIO 50 2T DIESIS - FLY - FREE 2001-> - LIBERTY 4T - NRG EXTREME - NRG EXTREME LC - NRG MC2 LC 1998-> - NRG MC3 DD LC - NRG MC3 DT - NRG MC3 Purejet LC - NRG Power DD LC - NRG Power DT (C453M) - NRG Power Purejet LC - TYPHOON 2007->2010 VESPA 50 2T Primavera euro 2 (C533M) - Sprint euro 2

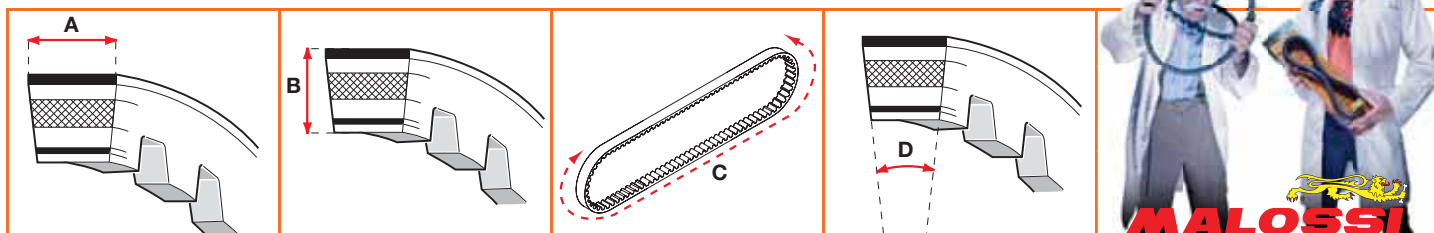

BELTS - Technical specifications in order of width

Width mm (A)	Thickness mm (B)	External size mm (C)	Angle (D)	CODE	Price €	MODEL	APPLICATIONS
18,8	10,6	814	28°	6116215	31.00	X K BELT	APRILIA 125 4T LC LEONARDO - LEONARDO 150 - SCARABEO (ROTAX) - SCARABEO 150 (ROTAX) - SCARABEO 200 (ROTAX) BETA 125 4T LC EIKON - EIKON 150 KYMCO 125 4T LC BET & WIN - BET & WIN 150 - DINK euro 0-1-2 - DINK 150 euro 0-1-2 - DINK 200 (SH 40 A) - DINK DD 200 ie (SJ 40) - GRAND DINK euro 0-1-2 - GRAND DINK 150 euro 0-1-2 MALAGUTI 125 4T LC F18 WARRIOR - F18 WARRIOR 150
19	8	769	30°	6116671	29.00	X K BELT	HONDA 50 ie 4T NSC50R euro 2 (AF72E) VISION (AF72E)
19	9,8	820	30°	6114118	38.25	X K BELT	APRILIA 50 2T MOJITO CUSTOM - SR (carb.) LC 2004-> (PIAGGIO) - SR DITECH GP1 LC (PIAGGIO C361M) - SR MOTARD euro 2 - SR R (carb.) LC (PIAGGIO) - SR R FACTORY LC (PIAGGIO C361M) DERBI 50 2T ATLANTIS - BULLET 2003-> - GP1 LC - GP1 OPEN LC - GP1 REVOLUTION LC GILERA 50 2T ICE - RUNNER LC - RUNNER PureJet LC <-2005 - RUNNER PureJet LC 2006-> - RUNNER SP LC <-2005 RUNNER SP (carb.) 50 2T LC 2006-> (C451M) STALKER - STORM - TYPHOON - TYPHOON X ITALJET 50 2T JET SET PEUGEOT 100 2T ELYSEO - SPEEDFIGHT - TREKKER - VIVACITY / NO KAT PIAGGIO 50 2T DIESIS - FLY - FREE <-2000 - NRG LC - NRG EXTREME - NRG EXTREME LC - NRG MC2 LC <-1997 - NRG MC2 LC 1998-> - NRG MC3 DD LC - NRG MC3 DT - NRG MC3 Purejet LC - NRG Power DD LC - NRG Power DT (C453M) - NRG Power Purejet LC - NTT LC - TYPHOON 2007->2010 VESPA 50 2T Primavera euro 2 (C533M) - Sprint euro 2
19	10	759	30°	6114117	40.67	X K BELT	GILERA 50 2T EASY MOVING PIAGGIO 50 2T QUARTZ LC - SFERA - SFERA RESTYLING - ZIP 2000-> - ZIP Fast Rider - ZIP SP LC -
	10,2	745	28°	6115104	45.41	X K BELT	VESPA 50 2T ET2 - LX - S euro 2 (C381M)
19	10,2	815	28°	6115668	44.88	X K BELT	APRILIA 50 2T MOJITO CUSTOM - SR (carb.) LC 2004-> (PIAGGIO) DERBI 50 2T SR MOTARD euro 2 - SR R (carb.) LC (PIAGGIO) ATLANTIS - BULLET 2003-> - GP1 LC - GP1 OPEN LC - GP1 REVOLUTION LC GILERA 50 2T ICE - RUNNER LC - RUNNER SP LC <-2005 - RUNNER SP (carb.) 50 2T LC 2006-> (C451M) - STALKER - TYPHOON X ITALJET 50 2T JET SET PIAGGIO 50 2T DIESIS - FLY - FREE 2001-> - NRG EXTREME - NRG EXTREME LC - NRG MC2 LC 1998-> - NRG MC3 DD LC - NRG MC3 DT - NRG Power DD LC - NRG Power DT (C453M) - TYPHOON 2007->2010 VESPA 50 2T Primavera euro 2 (C533M) - Sprint euro 2
19,5	9	924	28°	6117253	32.64	X SPECIAL BELT	SYM 125 4T HD Evo I ie LC euro 3
19,9	9,7	785	30°	6116148	31.00	X K BELT	PIAGGIO 125 ie 4T LIBERTY 3V euro 3 - LIBERTY iGet ABS euro 3 (M893M) VESPA 125 ie 4T Primavera 3V euro 3 2014-> (M811M) - Sprint 3V euro 3 2014-> - Sprint 3V 150 euro 3 2014->

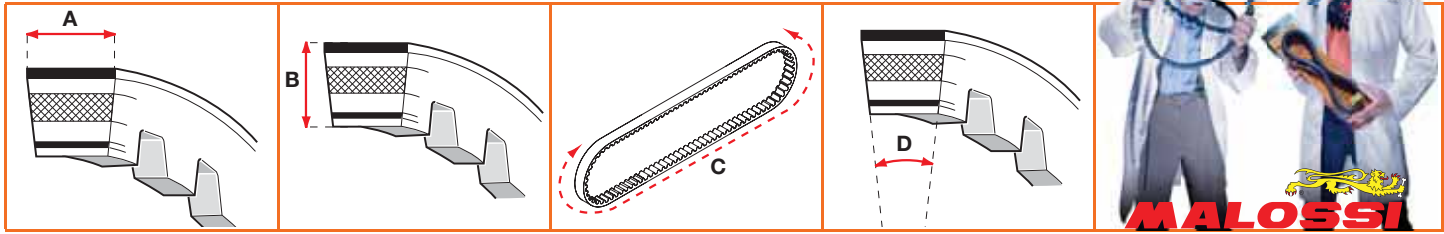

BELTS - Technical specifications in order of width

Width mm (A)	Thickness mm (B)	External size mm (C)	Angle (D)	CODE	Price €	MODEL	APPLICATIONS
20	9,5	799	30°	6113148	26.40	X K BELT	KYMC0 125 4T AGILITY euro 3 (KN25) - AGILITY 150 euro 3 - AGILITY R16 euro 3 (KL25B) - AGILITY R16 150 euro 3 (KL30) - AGILITY R16 i 200 LC euro 3 (KF40) - AGILITY RS euro 3 (KN25SR) - LIKE euro 3 (KA40) - LIKE 200 ie euro 3 (KA40) - MOVIE euro 3 - PEOPLE - PEOPLE S euro 3 - PEOPLE 150 - PEOPLE One ie euro 3 (KM25) - PEOPLE S 200 (BA 40) - SUPER 8 euro 3 (KL25) - VIVIO - VIVIO 150 MALAGUTI 125 4T CIAK MASTER - CIAK MASTER 150 - CIAK MASTER 200
20,7	9,7	884	32°	6115275	35.70	X K BELT	KYMC0 125 ie 4T LC DINK Street euro 3 (SK25) - DOWNTOWN euro 3 (SK25) - K-XCT euro 3 - PEOPLE GTi euro 3 (BF25) - SUPER DINK euro 3 (SK25)
21,5	10,5	830	32°	6112737	34.63	X K BELT	APRILIA 125 2T SR - SR 150 GILERA 125 2T RUNNER FX LC - RUNNER FXR - SP 180 LC TYPHOON X - TYPHOON ITALJET 125 2T DRAGSTER LC - DRAGSTER 180 LC PIAGGIO 125 2T HEXAGON LC - HEXAGON 150 LC HEXAGON LX LC - HEXAGON LXT 180 LC - SKIPPER - SKIPPER 150 - SKIPPER LX - SKIPPER LXT 150
22	9,3	796	28°	6116419	44.00	X K BELT	YAMAHA 125 4T LC CYGNUS X - CYGNUS X ie euro 3
22	9,3	809	28°	6116666	41.00	X K BELT	YAMAHA 125 4T BW'S ie euro 3 (E3G3E) ZUMA ie euro 3
22	9,3	832	28°	6116101	42.50	X K BELT	BENELLI 125 4T LC VELVET - VELVET 150 ITALJET 125 4T LC JUPITER - JUPITER 150 - MILLENNIUM - MILLENNIUM 150 MALAGUTI 125 4T LC PHANTOM MAX (YAMAHA) - MADISON (YAMAHA) - MADISON 150 (YAMAHA) MBK 125 4T LC DOODO - DOODO 150 - SKYLINER - SKYLINER 150 - THUNDER - THUNDER 150 YAMAHA 125 4T LC MAJESTY - MAJESTY 150 - MAJESTY 180 - MAXSTER - MAXSTER 150 - TEO'S - TEO'S 150
22	9,3	918	28°	6113059	59.36	X K BELT	MBK 125 4T LC CITYLINER ie euro 3 - SKYCRUISER ie euro 3 YAMAHA 125 4T LC X CITY ie euro 3 (E3A5E) - X MAX ie euro 3
22	9,7	880	28°	6116667	44.00	X K BELT	YAMAHA 125 4T LC TRICITY ie
22	10	835	30°	6114895	44.00	X K BELT	HONDA 125 4T LC PCX ie euro 3 <-2011 (JF28E) - PCX ie euro 3 2012-> (JF47) - SH mode ie euro 3 (JF51E)
22	10	849	30°	6113502	48.57	X K BELT	SUZUKI 125 4T LC BURGMAN K 7 ie euro 3 (F490)
22	13	824	28°	6115666	46.92	X K BELT	APRILIA 200 4T LC ATLANTIC (PIAGGIO M234M) GILERA 200 4T LC RUNNER ST euro 3 - RUNNER VXR 180 - RUNNER VXR <-2005 - RUNNER VXR 2006-> MALAGUTI 200 4T LC MADISON 180 (PIAGGIO) - MADISON (PIAGGIO) - PHANTOM MAX (PIAGGIO) PIAGGIO 200 4T LC LIBERTY - LIBERTY S 200 4T euro 3 (LEADER) - SUPER HEXAGON GTX 180 - X8 - X9 - X9 AMALFI 180 - VESPA 200 4T LC Granturismo L - GT (M312M)
22	13	945	28°	6116697	67.00	X K BELT	APRILIA 200 4T LC APRILIA SPORTCITY euro 3 (PIAGGIO M288M) PIAGGIO 200 4T LC BEVERLY - CARNABY euro 3 (LEADER M601M) - CARNABY 300 ie euro 3 (QUASAR)
22,2	11	888	30°	61 9956	42.23	X K BELT	SUZUKI 4T LC BURGMAN UH 200 ie euro 3 - BURGMAN AN 250

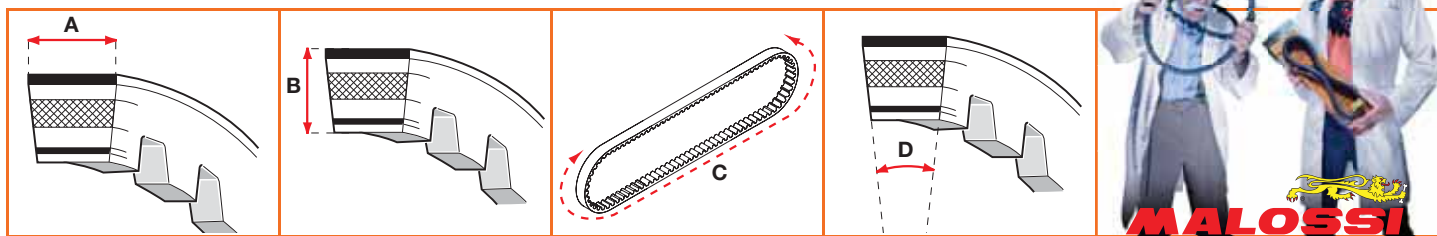

BELTS - Technical specifications in order of width

Width mm (A)	Thickness mm (B)	External size mm (C)	Angle (D)	CODE	Price €	MODEL	APPLICATIONS
22,3	10,5	924	30°	6114127	24.42	X SPECIAL BELT	BENELLI 150 4T LC CAFFÈNERO euro 3 (QJ158MJ) CF MOTO 150 4T LC URBAN R (1P 58 MJ) GARELLI 125 4T LC XO' ie euro 3 (1P52 QMI-2) - XO' 150 ie euro 3 (1P58 QM.J) HONDA 125 4T LC @ - @ 150 - DYLAN - DYLAN 150 - PANTHEON 2T - PANTHEON ie - PANTHEON 150 2T - PANTHEON 150 ie - PS ie euro 3 - PS 150 ie euro 3 - SH - SH Scoopy - SH - SH Scoopy 150 - SH I ie <-2008 - SH I ie euro 3 2009-> (JF14E) - SH I 150 ie <-2008 - SH I 150 ie euro 3 2009-> (KF08E) - S-Wing ie euro 3 - S-Wing 150 ie euro 3 (KF06E) KEEWAY 125 4T LC LOGIK euro 3 (QJ153MI-2) - OUTLOOK 150 (QJ158MJ) MALAGUTI 125 4T LC BLOG ie euro 3 (03) - BLOG 160 ie euro 3 (04) - CENTRO ie euro 3 - CENTRO 160 ie euro 3 (02) SUZUKI 125 4T LC SIXTEEN euro 3 (F499) - SIXTEEN 150 euro 3 (G421) WT MOTORS 152 4T LC ATENE (1P58MJA)
22,5	10	840	30°	61 9584	39.82	X K BELT	HONDA 250 4T LC CN PIAGGIO 250 4T LC HEXAGON
22,5	10	920	30°	6116422	48.57	X K BELT	BENELLI 150 4T LC CAFFÈNERO euro 3 (QJ158MJ) CF MOTO 150 4T LC URBAN R (1P 58 MJ) GARELLI 125 4T LC XO' ie euro 3 (1P52 QMI-2) - XO' 150 ie euro 3 (1P58 QM.J) HONDA 125 4T LC @ - @ 150 - DYLAN - DYLAN 150 - PANTHEON 2T - PANTHEON ie - PANTHEON 150 2T - PANTHEON 150 ie - PS ie euro 3 - PS 150 ie euro 3 - SH - SH Scoopy - SH - SH Scoopy 150 - SH I ie <-2008 - SH I ie euro 3 2009-> (JF14E) - SH I 150 ie <-2008 - SH I 150 ie euro 3 2009-> (KF08E) - S-Wing ie euro 3 - S-Wing 150 ie euro 3 (KF06E) KEEWAY 125 4T LC LOGIK euro 3 (QJ153MI-2) - OUTLOOK 150 (QJ158MJ) MALAGUTI 125 4T LC BLOG ie euro 3 (03) - BLOG 160 ie euro 3 (04) - CENTRO ie euro 3 - CENTRO 160 ie euro 3 (02) SUZUKI 125 4T LC SIXTEEN euro 3 (F499) - SIXTEEN 150 euro 3 (G421) WT MOTORS 152 4T LC ATENE (1P58MJA)

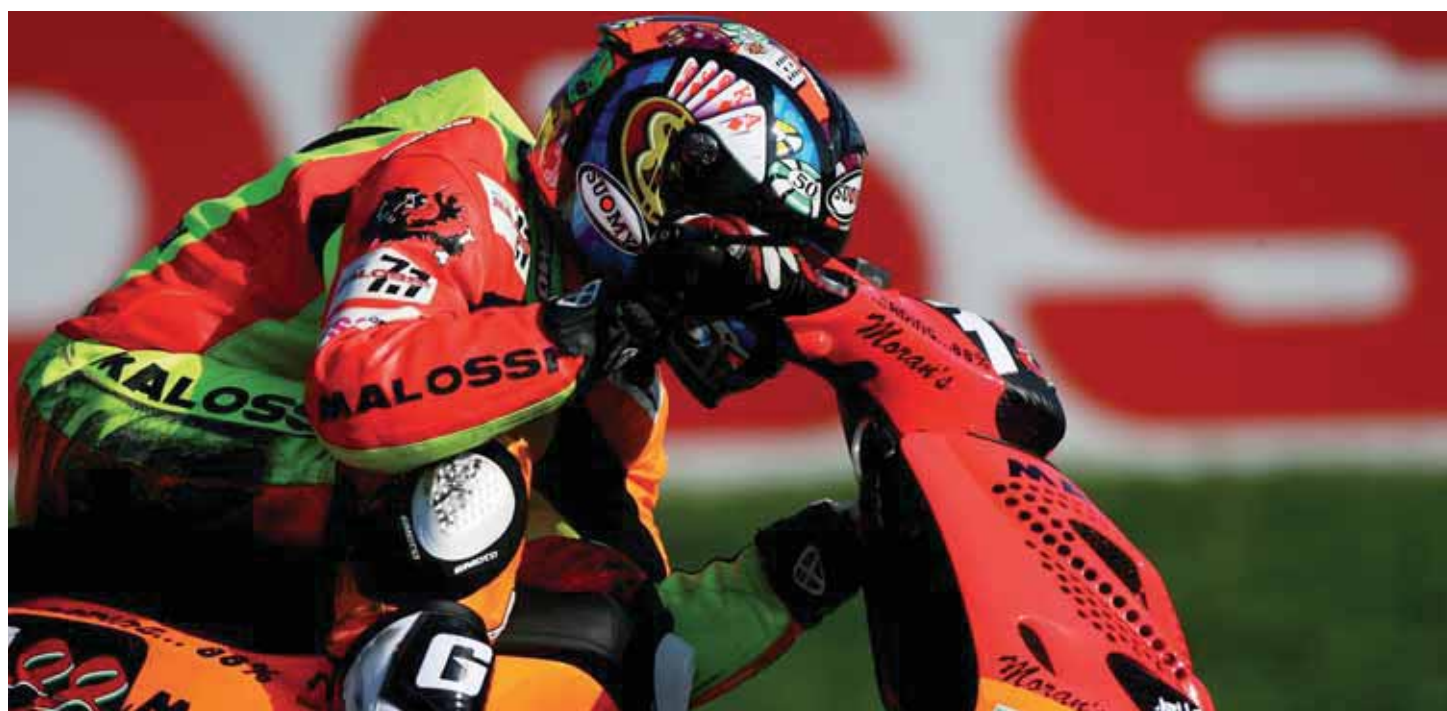

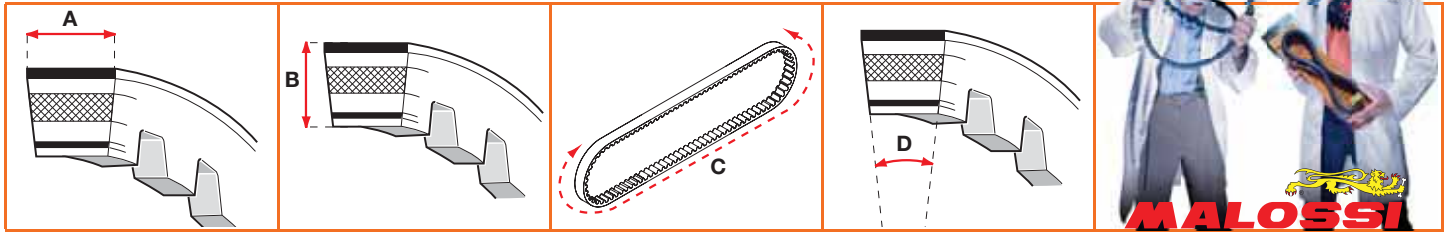

BELTS - Technical specifications in order of width

Width mm (A)	Thickness mm (B)	External size mm (C)	Angle (D)	CODE	Price €	MODEL	APPLICATIONS
22,5	10,5	814	30°	6116117	34.27	X K BELT	APRILIA 125 4T ATLANTIC - Arrecife LC - MOJITO RY (LEADER) - SPORTCITY ONE (LEADER M38AM) - SR MAX ie LC euro 3 - SR MOTARD euro 3 BENELLI 125 4T ADIVA (LEADER) - ADIVA 150 (LEADER) DERBI 125 4T BOULEVARD (LEADER) - BOULEVARD 150 (LEADER) GP1 LC euro 2-3 - VARIANT Sport GILERA 125 4T DNA LC - NEXUS LC euro 3 - NEXUS ie LC euro 3 - RUNNER ST LC euro 3 - RUNNER VX LC <-2005 - RUNNER VX LC 2006-> ITALJET 125 4T JET SET (LEADER) - JET SET 150 (LEADER) TORPEDO (LEADER) - TORPEDO 150 (LEADER) MALAGUTI 125 4T MADISON 3 LC (PIAGGIO) PIAGGIO 125 4T FLY euro 2-3 (LEADER M422M) - FLY 150 euro 2-3 (LEADER M422M) - NEW FLY 3V 125 ie euro 3 2012-> - LIBERTY - LIBERTY LE euro 1-2 (LEADER) - LIBERTY - LIBERTY LE 150 euro 1-2 (LEADER) - LIBERTY euro 3 (LEADER M389M) - LIBERTY 150 euro 3 (LEADER M672M) - LIBERTY 3V 150 ie euro 3 (M738M) - LIBERTY S euro 3 (LEADER M381M) - MP3 LC euro 3 (LEADER) - SKIPPER ST (LEADER) - SKIPPER ST 150 (LEADER) - SUPER HEXAGON GTX LC - TYPHOON euro 3 (LEADER M701M) - X7 LC euro 3 (LEADER) - X7 EVO ie LC euro 3 (QUASAR) - X8 LC euro 2-3 (LEADER) - X9 4V LC - X9 4V Evolution LC euro 2-3 - XEvo LC euro 3 (LEADER) - ZIP (LEADER) RENAULT 125 4T FULLTIME (LEADER) VESPA 125 4T 946 3V ABS ie (M801M) - ET4 (LEADER) - ET4 150 (LEADER) - Granturismo L - GT LC (LEADER) - GTS LC euro 3 (M315M) - GTS Super ie LC euro 3 <-2013 (M455M) - euro 3 2014-> - GTV LC (LEADER) - LX (LEADER) - LX ie euro 3 (LEADER) - LX 150 (LEADER) - LX 150 ie euro 3 (LEADER) - LX 3V ie euro 3 2012 (M687M) - LX 3V 150 ie euro 3 2012 - LXV ie euro 3 (LEADER) - Primavera 3V 150 ie euro 3 2014-> (M812M) - S euro 3 (LEADER M444M) - S 150 euro 3 (LEADER) - S 3V ie euro 3 2012->
22,5	10,5	937	30°	6116118	35.00	X K BELT	APRILIA 125 4T LC SCARABEO (PIAGGIO) - SPORTCITY (PIAGGIO M281M) DERBI 125 4T LC RAMBLA euro 3 (PIAGGIO M287M) PIAGGIO 125 4T LC BEVERLY <-2009 - BEVERLY ie euro 3 2010-> (QUASAR) - CARNABY euro 3 (LEADER M28FM) - MP3 YOURBAN 4V ie euro 3 2011-> - X10 ie euro 3 WT MOTORS 250 4T LC MIAMI (172MM)
22,5	11	1008	30°	6112714	55.71	X K BELT	MALAGUTI 250 4T LC PassWord CK MBK 300 4T LC KILIBRE (H314E) YAMAHA 250 4T LC VERSITY XC 300 (H314E) - X CITY ie euro 3 (G358E) - X MAX - X MAX ie euro 3 2008->

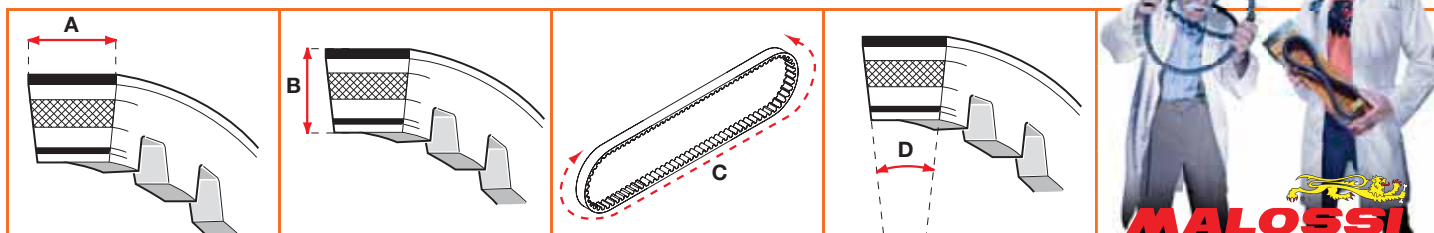

BELTS - Technical specifications in order of width

Width mm (A)	Thickness mm (B)	External size mm (C)	Angle (D)	CODE	Price €	MODEL	APPLICATIONS
22,6	13	834	28°	6113027	59.12	X K BELT	APRILIA 250 4T LC ATLANTIC - Arrecife (PIAGGIO M237M) - SR MAX 300 ie euro 3 DERBI 250 4T LC GP1 euro 2-3 GILERA 250 4T LC NEXUS ie euro 3 - NEXUS 300 ie euro 3 MALAGUTI 250 4T LC MADISON 3 (PIAGGIO) - MADISON RS (PIAGGIO M237M) - PHANTOM MAX (PIAGGIO M361M) PEUGEOT 250 4T LC SATELIS euro 3 PIAGGIO 250 4T LC MP3 ie euro 3 (QUASAR M472M) - MP3 300 ie euro 3 - MP3 YOURBAN 4V 300 ie euro 3 2011-> X7 ie euro 3 (QUASAR M622M) - X7 EVO 300 ie euro 3 (QUASAR) - X8 euro 2 - X8 ie euro 3 (QUASAR) - X9 Evolution (M237M) - XEvo ie euro 3 (QUASAR) VESPA 250 4T LC GTS ie - GTS Super 300 ie euro 3 (QUASAR M454M) - GTV ie - GTV 300 ie euro 3 (QUASAR)
22,6	13	955	28°	6116069	60.00	X K BELT	APRILIA 250 4T LC SCARABEO (PIAGGIO M285M) SCARABEO Light ie 2007-> SCARABEO Special 300 ie euro 3 (PIAGGIO M28RM) SPORTCITY ie euro 3 (PIAGGIO M288M) SPORTCITY CUBE 300 ie 4T LC euro 3 (LEADER M28LM) DERBI ie 4T LC RAMBLA 250 euro 3 - RAMBLA i 300 euro 3 (PIAGGIO) PEUGEOT 300 ie 4T LC GEOPOLIS 250 euro 3 - GEOPOLIS R/GT euro 3 - GeoRS euro 3 (PIAGGIO M28MM) PIAGGIO 250 4T LC BEVERLY euro 1-2 (M285M) - BEVERLY ie euro 3 - BEVERLY S ie euro 3 - BEVERLY 300 ie euro 3 - BEVERLY TOURER 300 ie euro 3
22,7	10,5	931	28°	6115676	32.64	X SPECIAL BELT	HONDA 125 ie 4T LC FORZA ABS (JF60E) - SH i ABS euro 3 2013-> (JF41E) - SH i ABS 150 euro 3 2013-> (KF13E)
23	11,4	871	28°	6116094	40.00	X K BELT	APRILIA 250 4T LC LEONARDO - LEONARDO 300 BENELLI 250 4T LC VELVET ITALJET 250 4T LC JUPITER MALAGUTI 250 4T LC MADISON (YAMAHA) MBK 250 4T LC SKYLINER YAMAHA 250 4T LC MAJESTY
23	14,8	947	28°	6112713	81.79	X K BELT	SUZUKI 400 4T LC BURGMAN AN-Business - BURGMAN AN ie <-2007 (K429)
23,2	10,5	949	30°	6116421	32.00	X K BELT	HONDA 250 4T LC FORESIGHT - FORZA 2001-> - JAZZ 2001-> - REFLEX 2001-> PEUGEOT 250 4T LC SV PIAGGIO 250 4T LC X9 (HONDA)
24	10,2	987	30°	6115276	63.24	X K BELT	KYMCO 200 ie 4T LC NIKITA euro 3 - PEOPLE GTi euro 3 (BF40) - SUPER DINK euro 3 (SK40)
24	10,5	912	30°	6116568	43.86	X K BELT	KYMCO 250 4T LC BET & WIN - GRAND DINK - KXR SPORT - MXU - MAXXER 300 - YUP (SH 50 D)
24	11,4	995	32°	6113028	53.76	X K BELT	KYMCO 250 4T LC PEOPLE - PEOPLE S euro 2 - PEOPLE S 300 ie euro 3 (BB60) - XCITING euro 2 - XCITING - XCITING R 300 ie euro 3
24	15	1041	30°	6113021	87.10	X K BELT	BENELLI 400 4T LC VELVET DUSK MALAGUTI 400 4T LC MADISON K
24,4	10,6	924	30°	6117205	44.80	X K BELT	SYM 250 ie 4T LC JOYMAX I euro 3 (HMA-1)
25	12,9	926	32°	6113104	79.29	X K BELT	HONDA 250 4T LC FORZA X <-2007
25,2	14,7	1004	30°	6115277	76.50	X K BELT	KAWASAKI 300 ie 4T LC J euro 3 (WS60) KYMCO 300 ie 4T LC DINK Street euro 3 (SK60) / euro 3 2012-> (SK60A) - DOWNTOWN euro 3 (SK60) / euro 3 2012-> (SK60A) - DOWNTOWN i ABS 350 euro 3 (SK64) - K-XCT euro 3 (SK60B) - NIKITA euro 3 - PEOPLE GTi euro 3 (BF60) - SUPER DINK euro 3 (SK60) / euro 3 2012-> (SK60A)
25,5	10,5	902	31°	6117244	43.00	X SPECIAL BELT	YAMAHA 125 4T N MAX ie LC euro 3 (E353E)
26	13,6	1093	28°	6115279	72.32	X K BELT	PIAGGIO 350 ie 4T LC BEVERLY Sport Touring euro 3 - X10 euro 3 (M762M)
26	14,8	1008	28°	6113396	94.61	X K BELT	SUZUKI 400 ie 4T LC BURGMAN K 7 - BURGMAN K 8 - BURGMAN K 9 - BURGMAN K10

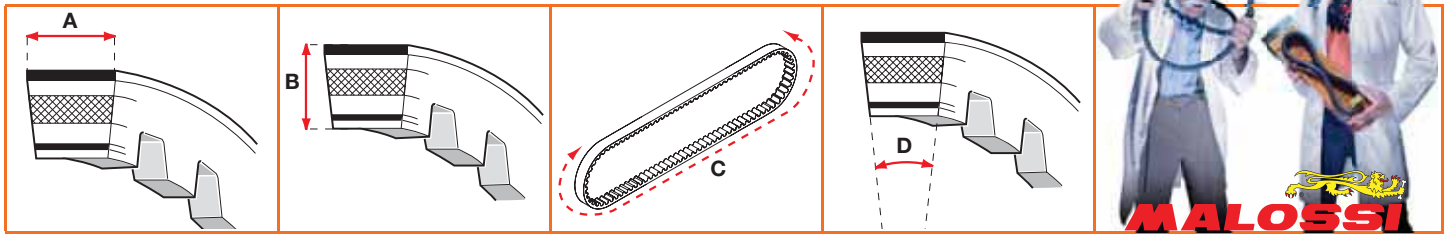

BELTS - Technical specifications in order of width

Width mm (A)	Thickness mm (B)	External size mm (C)	Angle (D)	CODE	Price €	MODEL	APPLICATIONS
26,2	10,5	969	31°	6115278	38.76	X K BELT	YAMAHA 125 ie 4T LC MAJESTY S - Smax - SMax 160 - Xenter - Xenter 150 (G397E)
26,4	13	1026	32°	6113590	97.21	X K BELT	HONDA 300 ie 4T LC FORZA ABS (NF04E) - SH I - SH I Scoopy (NF02E) - SH I euro 4 2015-> (NF05E)
26,5	14,4	1244	30°	6113500	120.51	X K BELT	HONDA 400 4T LC SILVER WING - SW-T euro 3 (NF01E)
26,5	14,4	1262	30°	6115803	79.60	X K BELT	HONDA 600 4T LC SILVER WING
28,7	16	1044	28°	6115125	91.20	X K BELT	APRILIA 400 4T LC ATLANTIC SPRINT - Arrecife (PIAGGIO M348M) - SCARABEO ie 2007-> - Light ie 2007-> - SCARABEO Light 500 ie 2007-> GILERA 500 ie 4T LC FUOCO euro 3 - NEXUS euro 2-3 MALAGUTI 500 4T LC SPIDERMAX GT (PIAGGIO M341M) PEUGEOT 400 4T LC GEOPOLIS euro 3 - SATELIS euro 3 - SATELIS 500 euro 3 PGO 500 4T LC BUG RACER (PIAGGIO) PIAGGIO 400 4T LC BEVERLY ie euro 3 (M345M) - BEVERLY TOURER ie euro 3 (M345M) BEVERLY 500 ie euro 3 - BEVERLY CRUISER 500 ie euro 3 - MP3 ie euro 3 (MASTER M474M) - MP3 500 ie euro 3 - X8 ie euro 3 (M521M) - X9 Evolution-Street 500 - X10 500 ie euro 3 - XEvo ie euro 3 (M521M)
28,9	14,7	1036	28°	6116100	105.00	X K BELT	KYMCO 500 4T LC XCITING euro 2-3 - XCITING R euro 3 (SB A0)
30	14,7	1018	26°	6116079	57.00	X K BELT	KYMCO 400 ie 4T LC XCITING euro 3 (SK80)
30	15	912	26°	6112960	91.62	X K BELT	YAMAHA 400 4T LC MAJESTY <-2008 (H317E)
30,1	14,7	931	28°	6115280	77.15	X K BELT	YAMAHA 400 4T LC MAJESTY euro 3 2009-> (H322E) - X MAX ie euro 3 (H330E)
31,2	16	908	28°	6116011	127.88	X K BELT	YAMAHA 530 ie 4T LC T MAX 2012-> (J409E)
32,2	14,9	892	28°	6114674	105.76	X K BELT	YAMAHA 500 4T LC T MAX (carb.) 2001->2003 - T MAX ie 2004->2011
32,4	16,9	894	28°	6115687	96.90	X K BELT	BMW ie 4T LC C Sport 600 euro 4 - C Sport 650 euro 4 2016-> (652EA) - C GT 650 euro 4
32,7	16,9	960	28°	6115126	118.46	X K BELT	APRILIA 850 ie 4T LC SRV 850 euro 3 (PIAGGIO M554M) GILERA 800 4T LC GP (PIAGGIO M554M)



Bracelet K Belt Malossi

- 4116002.00 € 4,00** Neon Orange
4116002.YO € 4,00 Neon Yellow
4116002.BO € 4,00 Black



Malossi recommends to perform belt maintenance following the instructions given by the vehicle manufacturers.

HIGH RESISTANCE ROLLERS for original variators and Multivar

HTRolls are made of a special compound CPT. The relative weight of each roller is clearly marked on one side. HTRolls are High Tech replacement parts for the original rollers; a complete calibrated set capable of varying your scooter's transmission ratio by perfectly regulating velocity and acceleration.

Function. Due to the rotation of the variator, the roller's weight creates a centrifugal force; the greater the roller weight, the greater the centrifugal force, therefore resulting with a faster gear change and viceversa.

Variator Calibration. To optimise your engine's performance, use rollers that maintain your engine's RPMs at your engine's peak power RPMs. Reducing the roller weights will increase the engine's RPMs and increasing the roller weights will reduce the engine's RPMs.



66 9417.AO gr. 03,2
ATTENTION: When ordering please remember to attach the code letter/number that represents the desired weight to the part number. See example above in RED.

66 9417 € 7,24
Kit 6 HTRoll
Ø 15x12

66 9417.AO	gr. 03,2
66 9417.BO	gr. 03,5
66 9417.CO	gr. 03,7
66 9417.DO	gr. 04,2
66 9417.EO	gr. 04,8
66 9417.FO	gr. 05,4
66 9417.GO	gr. 06
66 9417.HO	gr. 06,5
66 9417.IO	gr. 06,8
66 9417.LO	gr. 07,2
66 9417.MO	gr. 07,8
66 9417.NO	gr. 08,3
66 9417.OO	gr. 08,7
66 9417.PO	gr. 09,2

66 9999 € 8,50
Kit 6 HTRoll
Ø 17x12,3

66 9999.AO	gr. 04
66 9999.BO	gr. 04,5
66 9999.CO	gr. 05
66 9999.DO	gr. 05,5
66 9999.EO	gr. 06
66 9999.FO	gr. 06,5
66 9999.GO	gr. 07
66 9999.HO	gr. 08

66 9456 € 12,00
Kit 6 HTRoll
Ø 19x17

66 9456.AO	gr. 05,4
66 9456.BO	gr. 06,1
66 9456.CO	gr. 06,6
66 9456.DO	gr. 07,4
66 9456.EO	gr. 07,7
66 9456.FO	gr. 08,7
66 9456.GO	gr. 09,3
66 9456.HO	gr. 10
66 9456.IO	gr. 10,7
66 9456.LO	gr. 12
66 9456.MO	gr. 12,5

6611095 € 13,64
Kit 6 HTRoll
Ø 20x17

6611095.BO	gr. 07
6611095.CO	gr. 07,5
6611095.DO	gr. 08
6611095.EO	gr. 08,5
6611095.FO	gr. 09
6611095.GO	gr. 09,5
6611095.HO	gr. 10
6611095.IO	gr. 10,5
6611095.MO	gr. 11,5
6611095.OO	gr. 12,5
6611095.PO	gr. 13
6611095.QO	gr. 13,5
6611095.RO	gr. 14
6611095.SO	gr. 14,5
6611095.TO	gr. 15
6611095.UO	gr. 15,5
6611095.VO	gr. 16

6613561 € 26,00
Kit 8 HTRoll
Ø 25x14,9

6613561.ZO	gr. 10
6613561.VO	gr. 11
6613561.AO	gr. 12
6613561.BO	gr. 13
6613561.CO	gr. 14
6613561.DO	gr. 15
6613561.EO	gr. 16
6613561.GO	gr. 18
6613561.LO	gr. 20

6611367 € 23,75
Kit 8 HTRoll
Ø 26x12,8

6611367.CO	gr. 14
6611367.DO	gr. 15
6611367.EO	gr. 16
6611367.GO	gr. 18
6611367.LO	gr. 21

66 9823 New € 9,98
Kit 6 HTRoll
Ø 16x13

66 9823.AO	gr. 02,7
66 9823.BO	gr. 03
66 9823.CO	gr. 03,3
66 9823.DO	gr. 03,6
66 9823.EO	gr. 03,9
66 9823.FO	gr. 04,1
66 9823.GO	gr. 04,4
66 9823.HO	gr. 04,7
66 9823.IO	gr. 05,1
66 9823.LO	gr. 06
66 9823.MO	gr. 07
66 9823.QO	gr. 07,5
66 9823.NO	gr. 08
66 9823.RO	gr. 08,5
66 9823.OO	gr. 09
66 9823.PO	gr. 10
66 9823.TO	gr. 12
66 9823.SO	gr. 14

6614705 € 16,50
Kit 6 HTRoll
Ø 18x14

6614705.AO	gr. 09
6614705.BO	gr. 10
6614705.DO	gr. 13
6614705.FO	gr. 14
6614705.HO	gr. 15

6611156 € 20,11
Kit 6 HTRoll
Ø 20x12

6611156.AO	gr. 08
6611156.BO	gr. 08,5
6611156.CO	gr. 09
6611156.DO	gr. 09,5
6611156.EO	gr. 10
6611156.FO	gr. 10,5
6611156.GO	gr. 11
6611156.HO	gr. 12
6611156.IO	gr. 13
6611156.LO	gr. 14
6611156.MO	gr. 14,5

6613697 € 18,00
Kit 6 HTRoll
Ø 20,9x17

6613697.CO	gr. 09
6613697.FO	gr. 10
6613697.IO	gr. 11

6615452 € 27,00
Kit 8 HTRoll
Ø 25x15,9

6615452.IO	gr. 10
6615452.HO	gr. 11
6615452.GO	gr. 12
6615452.FO	gr. 13
6615452.EO	gr. 14
6615452.DO	gr. 15
6615452.CO	gr. 16

6611779 € 28,39
 Dismantled rollers
Kit 8 HTRoll
Ø 28x19,9

6611779.EO	gr. 26
------------	--------

6615437 € 28,39
Kit 8 HTRoll
Ø 28,2x19,9

6615437.WO	gr. 17
6615437.YO	gr. 18
6615437.ZO	gr. 19
6615437.BO	gr. 21
6615437.CO	gr. 24
6615437.GO	gr. 28

66 9420 € 10,00
Kit 6 HTRoll
Ø 19x15,5

66 9420.QO	gr. 02,7
66 9420.RO	gr. 02,9
66 9420.SO	gr. 03
66 9420.TO	gr. 03,2
66 9420.UO	gr. 03,3
66 9420.VO	gr. 03,5
66 9420.WO	gr. 03,7
66 9420.ZO	gr. 03,8
66 9420.YO	gr. 04
66 9420.AO	gr. 04,3
66 9420.BO	gr. 04,7
66 9420.CO	gr. 05
66 9420.EO	gr. 05,5
66 9420.FO	gr. 05,7
66 9420.GO	gr. 06,1
66 9420.IO	gr. 06,5
66 9420.MO	gr. 07,2
66 9420.NO	gr. 07,5
66 9420.OO	gr. 08,4
66 9420.PO	gr. 09,3
66 9420.QO	gr. 10
66 9420.JO	gr. 11
66 9420.KO	gr. 12
66 9420.LO	gr. 13

66 9919 € 22,15
Kit 8 HTRoll
Ø 20x12

66 9919.CO	gr. 09
66 9919.DO	gr. 09,5
66 9919.EO	gr. 10
66 9919.FO	gr. 10,5
66 9919.GO	gr. 11
66 9919.HO	gr. 12
66 9919.IO	gr. 13
66 9919.LO	gr. 14
66 9919.MO	gr. 14,5

66 9917 € 19,12
Kit 6 HTRoll
Ø 23x18

66 9917.JO	gr. 11
66 9917.AO	gr. 12
66 9917.BO	gr. 13
66 9917.CO	gr. 14
66 9917.EO	gr. 15
66 9917.GO	gr. 16
66 9917.IO	gr. 17
66 9917.MO	gr. 18
66 9917.OO	gr. 19
66 9917.QO	gr. 20
66 9917.SO	gr. 22
66 9917.UO	gr. 25
66 9917.ZO	gr. 27

6613554 € 26,00
Kit 8 HTRoll
Ø 25x17

6613554.HO	gr. 13
6613554.AO	gr. 14
6613554.BO	gr. 15
6613554.CO	gr. 16

6615657 € 35,00
Kit 8 HTRoll
Ø 29,8x19,8

6615657.DO	gr. 20
6615657.FO	gr. 22
6615657.HO	gr. 24
6615657.LO	gr. 26
6615657.RO	gr. 33

6612040 € 8,07
Kit 6 HTRoll
Ø 16x13

6612040.AO	gr. 04
6612040.DO	gr. 06
6612040.EO	gr. 07
6612040.FO	gr. 08
6612040.GO	gr. 09
6612040.LO	gr. 12

6611534 € 11,00
Kit 6 HTRoll
Ø 20x14,6

6611534.YO	gr. 08,5
6611534.ZO	gr. 09,5
6611534.AO	gr. 10,5
6611534.BO	gr. 11,5
6611534.CO	gr. 12,5
6611534.DO	gr. 13,5
6611534.FO	gr. 14,5
6611534.HO	gr. 15,5
6611534.NO	gr. 17,5

66 9915 € 17,80
Kit 6 HTRoll
Ø 23,8x18

66 9915.AO	gr. 18
66 9915.BO	gr. 19
66 9915.CO	gr. 21
66 9915.DO	gr. 23

6613655 € 27,00
Kit 8 HTRoll
Ø 25x19

6613655.CO	gr. 17
6613655.EO	gr. 18
6613655.HO	gr. 19

6612124 € 15,59
 Dismantled rollers
Kit 6 HTRoll
Ø 25x22,2

6612124.DO	gr. 22
6612124.GO	gr. 30

6613968 € 17,81
Kit 6 HTRoll
Ø 25x22,2

6613968.AO	gr. 20
6613968.BO	gr. 24
6613968.CO	gr. 26
6613968.EO	gr. 28

New

Centrifugal clutch system with clutch bell.

Two products that Malossi produces and sells separately, with great success.

Malossi now offers these two quality products paired, guaranteeing the optimal scooter transmission performance.

Due to the strong demand for these two products, we decided to offer them both in a single package.

This allows Malossi to supply two quality products with a cost savings for the customer.

Further improving a product is Malossi's passion, constantly searching for any aspect to improve hence optimizing operation and increasing reliability and safety. This directly benefits the customer.

Maxi Fly Clutch

Fly Clutch is a reinforced centrifugal clutch designed to easily withstand extreme operation, for example, constant stop and go on steep roads, city traffic, long series of traffic lights, especially with a passenger, and during hot weather when it becomes difficult to control scooter temperature levels.

Fly profits greatly from Malossi's experience, results acquired from research and thousands of tests performed in the field of scooter racing.

Maxi Delta Clutch

Delta Clutch is a clutch developed within the scooter racing circuits and in a short period has become a benchmark product, key to scooter performance.

The simplicity of the system quickly allows spring adjustment with regards to centrifugal force and the possibility of interchanging a spring with different K values. These values are listed in the Malossi catalogue.

Another option this system allows is position adjustment of the small mass which determines the pressure between friction material and clutch bell. In addition, this small mass is interchangeable with other masses of varying weights.

The complete system is patented to protect against shameless attempts to copy and falsify the product.

Delta has attained the recognition of many qualified tuners and the facts are the proof: used by all the racing teams and a vast amount of sport riders, resulting in a continuous increase in sales.

As always, Malossi constantly analyses its products during their operation and Delta is no exemption. It has been optimized by implementing small but important updates, maintaining Delta as a leading edge product.

We are very proud of the fact that Malossi clutches are asbestos free, however, much investment in research was needed in achieving this present level of quality, reliability, and especially selection of friction materials.

We can now affirm, with great certainty, that we possess an exclusive formula for producing a high temperature resistant material that does not alter its coefficient of friction due to prolonged operational stresses.

Maxi Clutch Bell

Technical Specifications

- Clutch Bell forged using Fe P04 deep-drawing steel;
- Carbon steel centre hub made of round stock and TIG welded;
- Anti-vibration band welded using a 3 point 120° pattern;
- 100% dynamically balanced;
- Surface hardened through nitriding.

Wing Clutch Bell

Technical Specifications

- Clutch Bell forged using Fe P04 deep-drawing steel;
- Carbon steel centre hub made of round stock and TIG welded;
- Surface hardened through nitriding;
- Finned reinforcement ring, made of machined carbon steel, black oxide surface finish, press fit;
- 100% dynamically balanced.

New



MALOSSI

Maxi Fly System



Maxi Fly Clutch

Maxi Clutch Bell



for MAXI SCOOTER

System comprises the famous:

- Reinforced clutch for extreme street use (**Maxi Fly Clutch**)
- In addition, steel (P04) clutch bell (**Maxi Clutch Bell**) dynamically balanced.

MAXI FLY SYSTEM		Maxi Fly Clutch			Maxi Clutch Bell		Ø	N.B.
5214724	€ 83,00	5212522	€ 70,37	+	7714325	€ 33,00	125	
5214727	€ 89,00	5212544	€ 70,37	+	7714335	€ 41,00	120	
5216181	€ 175,00	5213296	€ 146,14	+	7715576B	€ 70,00	160	
5216202	€ 149,94	5212813	€ 146,14	+	7715579B	€ 49,00	160	
5216331	€ 165,00	5212819	€ 146,14	+	7715582B	€ 60,00	160	
5217362	€ 165,00	5217041	€ 146,14	+	7717027B	€ 52,00	152	Sport
5217420	€ 175,00	5217041	€ 146,14	+	7715900B	€ 59,00	153	MHR
5217363	€ 110,00	5217088B	€ 70,37	+	7717083B	€ 60,00	130	
5217404	€ 238,00	5213060	€ 146,14	+	7714329	€ 124,20	150	

Maxi Delta System



Maxi Delta Clutch

Maxi Clutch Bell



for MAXI SCOOTER

System comprises the famous:

- Patented adjustable clutch (**Maxi Delta Clutch**)
- In addition, the reinforced, anti-failure clutch bell (**Maxi Clutch Bell**) dynamically balanced, designed for competitive and sport applications.

MAXI DELTA SYSTEM		Maxi Delta Clutch			Maxi Clutch Bell		Ø
5214721	€ 137,70	5211835	€ 128,41	+	7713369	€ 56,50	145
5216070	€ 125,46	5212487	€ 112,59	+	7713376	€ 39,14	125
5216184	€ 136,00	5211467	€ 129,23	+	7715916B	€ 53,04	135
5216569	€ 135,00	5216462	€ 120,42	+	7715647	€ 44,29	134
5216918	€ 136,00	5211821	€ 120,42	+	7715898B	€ 53,04	134
5217405	€ 137,70	5211468	€ 129,23	+	7713368	€ 59,00	135
5217406	€ 125,46	5211888	€ 120,42	+	7713368	€ 59,00	135
New 5217490	€ 137,70	5216462	€ 120,42	+	7717430B New	€ 52,00	134

New**MALOSS**

Applications	clutch	MAXI FLY SYSTEM	clutch BELL	clutch	MAXI DELTA SYSTEM	clutch BELL	(*)	N.B.
SCOOTER								
HONDA VISION 110 ie 4T (JF31E)	5212522	---	---	5212487	5216070	7713376	125	
MAXI SCOOTER								
APRILIA ATLANTIC - Arrecife 125 4T LC	---	---	---	5211821	5216918	7715898B	134	
ATLANTIC - Arrecife 200 4T LC (PIAGGIO M234M)	---	---	---	5211821	5216918	7715898B	134	
ATLANTIC - Arrecife 250 4T LC (PIAGGIO M237M)	---	---	---	5211821	5216918	7715898B	134	
ATLANTIC SPRINT - Arrecife 400 4T LC (PIAGGIO M348M)	5212813	5216202	7715579B	---	---	---	160	
ATLANTIC 500 4T LC	5212813	5216202	7715579B	---	---	---	160	
ATLANTIC SPRINT - Arrecife 500 4T LC (PIAGGIO M273M)	5212813	5216202	7715579B	---	---	---	160	
LEONARDO 125 - 150 4T LC	5212539	---	---	5212492	---	---	134	
LEONARDO 250 4T LC	---	---	---	5211468	5217405	7713368	135	
LEONARDO 300 4T LC	---	---	---	5211835	5214721	7713369	145	
MOJITO RY 125 4T (LEADER)	---	---	---	5211821	5216918	7715898B	134	
SCARABEO 125 4T LC (PIAGGIO)	---	---	---	5211821	5216918	7715898B	134	
SCARABEO 125 - 150 4T LC (ROTAX)	5212539	---	---	5212492	---	---	134	
SCARABEO Light 125 4T LC euro 3 (APRILIA BA03)	---	---	---	5211821	---	---	134	
SCARABEO Light 125 ie 4T LC euro 3 (APRILIA BB01)	---	---	---	5211821	---	---	134	
SCARABEO Light 200 ie 4T LC euro 3 (APRILIA CA03-CB01)	---	---	---	5211821	---	---	134	
SCARABEO 250 4T LC (PIAGGIO M285M)	---	---	---	5211821	5216918	7715898B	134	
SCARABEO Light 250 ie 4T LC 2007->	---	---	---	5211821	5216918	7715898B	134	
SCARABEO Special 300 ie 4T LC euro 3 (PIAGGIO M28RM)	---	---	---	5211821	5216918	7715898B	134	
SCARABEO 400 ie 4T LC 2007->	5212813	5216202	7715579B	---	---	---	160	
SCARABEO Light 400 ie 4T LC 2007->	5212813	5216202	7715579B	---	---	---	160	
SCARABEO 500 4T LC	5212813	5216202	7715579B	---	---	---	160	
SCARABEO Light 500 ie 4T LC 2007->	5212813	5216202	7715579B	---	---	---	160	
SPORTCITY 125 4T LC (PIAGGIO M281M)	---	---	---	5211821	5216918	7715898B	134	
SPORTCITY ONE 125 4T (LEADER M38AM)	---	---	---	5211821	5216918	7715898B	134	
SPORTCITY 200 4T LC euro 3 (PIAGGIO)	---	---	---	5211821	5216918	7715898B	134	
SPORTCITY 250 ie 4T LC euro 3 (PIAGGIO M288M)	---	---	---	5211821	5216918	7715898B	134	
SPORTCITY CUBE 300 ie 4T LC euro 3 (LEADER M28LM)	---	---	---	5211821	5216918	7715898B	134	
SR 125 - 150 2T	5212840	---	---	5211481	---	---	134	
SR MAX 125 ie 4T LC euro 3	---	---	---	5211821	5216918	7715898B	134	
SR MAX 300 ie 4T LC euro 3	---	---	---	5211821	5216918	7715898B	134	
SR MOTARD 125 4T euro 3	---	---	---	5211821	5216918	7715898B	134	
BENELLI ADIVA 125 - 150 4T (LEADER)	---	---	---	5211821	5216918	7715898B	134	
ADIVA AD 250 4T LC euro 2	---	---	---	5211821	5216918	7715898B	134	
CAFFÈNERO 150 4T LC euro 3 (QJ158MJ)	5212522	5214724	7714325	5212487	5216070	7713376	125	
VELVET 150 4T LC	---	---	---	5211888	5217406	7713368	135	
VELVET 250 4T LC	---	---	---	5211468	5217405	7713368	135	
VELVET DUSK 400 4T LC	---	---	7714329	---	---	---	150	
CF MOTO URBAN R 150 4T LC (1P 58 MJ)	5212522	5214724	7714325	5212487	---	---	125	
DERBI BOULEVARD 125 - 150 4T (LEADER)	---	---	---	5211821	5216918	7715898B	134	
BOULEVARD 200 4T (PIAGGIO M387M)	---	---	---	5211821	5216918	7715898B	134	
GP1 125 4T LC euro 2-3	---	---	---	5211821	5216918	7715898B	134	
GP1 250 4T LC euro 2-3	---	---	---	5211821	5216918	7715898B	134	
RAMBLA 125 4T LC euro 3 (PIAGGIO M287M)	---	---	---	5211821	5216918	7715898B	134	
RAMBLA 250 ie 4T LC euro 3	---	---	---	5211821	5216918	7715898B	134	
RAMBLA i 300 ie 4T LC euro 3 (PIAGGIO)	---	---	---	5211821	5216918	7715898B	134	
VARIANT Sport 125 4T	---	---	---	5211821	5216918	7715898B	134	
GARELLI XO' 125 - 150 ie 4T euro 3	5212522	5214724	7714325	5212487	5216070	7713376	125	
GILERA DNA 125 4T LC	---	---	---	5211821	5216918	7715898B	134	
DNA 180 4T LC	---	---	---	5211821	5216918	7715898B	134	
FUOCO 500 ie 4T LC euro 3	5212813	5216202	7715579B	---	---	---	160	
NEXUS 125 4T LC euro 3	---	---	---	5211821	5216918	7715898B	134	
NEXUS 125 ie 4T LC euro 3	---	---	---	5211821	5216918	7715898B	134	
NEXUS 250 ie 4T LC euro 3	---	---	---	5211821	5216918	7715898B	134	
NEXUS 300 ie 4T LC euro 3	---	---	---	5211821	5216918	7715898B	134	
NEXUS 500 ie 4T LC euro 2-3	5212813	5216202	7715579B	---	---	---	160	
RUNNER FX 125 2T LC	5212840	---	---	5211481	---	---	134	
RUNNER FXR - SP 180 2T LC	5212840	---	---	5211481	---	---	134	
RUNNER ST 125 4T LC euro 3	---	---	---	5211821	5216918	7715898B	134	
RUNNER ST 200 4T LC euro 3	---	---	---	5211821	5216918	7715898B	134	
RUNNER VX 125 4T LC	---	---	---	5211821	5216918	7715898B	134	
RUNNER VXR 180 4T LC	---	---	---	5211821	5216918	7715898B	134	
RUNNER VXR 200 4T LC	---	---	---	5211821	5216918	7715898B	134	
TYPHOON 125 2T	5212840	---	---	5211481	---	---	134	
TYPHOON X 125 2T	5212840	---	---	5211481	---	---	134	

(*) : for clutch bell Ø

(N) : ATTENTION * ONLY FOR vehicles CIRCULATING in: INDONESIA - SINGAPORE - THAILAND - VIETNAM

New



MALOSSI

467

52 CLUTCH SYSTEM

Applications	MAXI FLY SYSTEM			MAXI DELTA SYSTEM			(*)	N.B.
	clutch	clutch BELL	clutch BELL	clutch	clutch BELL	clutch BELL		
HONDA @ 125 - 150 4T LC	5212522	5214724	7714325	5212487	5216070	7713376	125	
CN 250 4T LC	---	---	---	5211467	---	---	135	
DYLAN 125 - 150 4T LC	5212522	5214724	7714325	5212487	5216070	7713376	125	
FORESIGHT 250 4T LC	---	---	---	5211467	5216184	7715916B	135	
FORZA ABS 125 ie 4T LC (JF60E)	---	---	---	5217040	---	7715916B	135	
FORZA 250 4T LC 2001->	---	---	---	5211467	5216184	7715916B	135	
FORZA X 250 4T LC	---	---	---	5211467	5216184	7715916B	135	
FORZA ABS 300 ie 4T LC (NF04E)	---	---	---	5211467	5216184	7715916B	135	
HELIX 250 4T LC	---	---	---	5211467	---	---	135	
JAZZ 250 4T LC 2001->	---	---	---	5211467	5216184	7715916B	135	
PANTHEON 125 - 150 2T LC	---	---	---	5211553	---	7715916B	135	
PANTHEON 125 - 150 ie 4T LC	5212522	5214724	7714325	5212487	5216070	7713376	125	
PCX 125 - 150 ie 4T LC euro 3	5212522	5214724	7714325	5212487	5216070	7713376	125	
PS 125 - 150 ie 4T LC euro 3	5212522	5214724	7714325	5212487	5216070	7713376	125	
REFLEX 250 4T LC 2001->	---	---	---	5211467	5216184	7715916B	135	
SH - SH Scoopy 125 - 150 4T LC	5212522	5214724	7714325	5212487	5216070	7713376	125	
SH I 125 - 150 ie 4T LC <-2008	5212522	5214724	7714325	5212487	5216070	7713376	125	
SH I 125 - 150 ie 4T LC euro 3 2009->	5212522	5214724	7714325	5212487	5216070	7713376	125	
SH I ABS 125 - 150 ie 4T LC euro 3 2013->	5212522	5214724	7714325	5212487	5216070	7713376	125	
SH mode 125 ie 4T LC euro 3 (JF51E)	5212522	5214724	7714325	5212487	5216070	7713376	125	
SH I - SH I Scoopy 300 ie 4T LC 2014-> (NF02E)	---	---	---	5211467	5216184	7715916B	135	
SH I 300 ie 4T LC euro 4 2015-> (NF05E)	---	---	---	5211467	5216184	7715916B	135	
SILVER WING 400 4T LC	5212823	---	---	---	---	---	160	
SILVER WING 600 4T LC	5212823	---	---	---	---	---	160	
S-Wing 125 - 150 ie 4T LC euro 3	5212522	5214724	7714325	5212487	5216070	7713376	125	
SW-T 400 4T LC euro 3 (NF01E)	5212823	---	---	---	---	---	160	
SW-T 600 4T LC euro 3 (PF01E)	5212823	---	---	---	---	---	160	
ITALJET DRAGSTER 125 2T LC	5212840	---	---	5211481	---	---	134	
DRAGSTER 180 2T LC	5212840	---	---	5211481	---	---	134	
JET SET 125 - 150 4T (LEADER)	---	---	---	5211821	5216918	7715898B	134	
JUPITER 150 4T LC	---	---	---	5211888	5217406	7713368	135	
JUPITER 250 4T LC	---	---	---	5211468	5217405	7713368	135	
MILLENNIUM 150 4T LC	---	---	---	5211888	5217406	7713368	135	
TORPEDO 125 - 150 4T (LEADER)	---	---	---	5211821	5216918	7715898B	134	
KAWASAKI J ABS 125 ie 4T LC euro 3 (WS25)	5212522	5214724	7714325	5212487	5216070	7713376	125	
J 300 ie 4T LC euro 3 (WS60)	5217041	5217362	7717027B	---	---	---	152	SPORT
J 300 ie 4T LC euro 3 (WS60)	5217041	5217420	7715900B	---	---	---	153	MHR
KEEWAY LOGIK 125 4T LC euro 3 (QJ153MI-2)	5212522	5214724	7714325	5212487	5216070	7713376	125	
OUTLOOK 125 - 150 4T LC	5212522	5214724	7714325	5212487	5216070	7713376	125	
KYMCO AGILITY 125 - 150 4T euro 3	5212522	5214724	7714325	5212487	---	---	125	
AGILITY R16 125 4T euro 3 (KL25B)	5212522	5214724	7714325	5212487	5216070	7713376	125	
AGILITY R16 150 4T euro 3 (KL30)	5212522	5214724	7714325	5212487	---	---	125	
AGILITY RS 125 4T euro 3 (KN25SR)	5212522	5214724	7714325	5212487	5216070	7713376	125	
AGILITY R16 i 200 4T LC euro 3 (KF40-KF40B)	5212522	5214724	7714325	5212487	---	---	125	
BET & WIN 250 4T LC	5217041	5217362	7717027B	---	---	---	152	SPORT
BET & WIN 250 4T LC	5217041	5217420	7715900B	---	---	---	153	MHR
DINK Street 125 ie 4T LC euro 3 (SK25)	5217088B	5217363	7717083B	---	---	---	130	
DINK Street 300 ie 4T LC euro 3 (SK60)	5217041	5217362	7717027B	---	---	---	152	SPORT
DINK Street 300 ie 4T LC euro 3 (SK60)	5217041	5217420	7715900B	---	---	---	153	MHR
DINK Street 300 ie 4T LC euro 3 2012-> (SK60A)	5217041	5217362	7717027B	---	---	---	152	SPORT
DINK Street 300 ie 4T LC euro 3 2012-> (SK60A)	5217041	5217420	7715900B	---	---	---	153	MHR
DOWNTOWN 125 ie 4T LC euro 3 (SK25)	5217088B	5217363	7717083B	---	---	---	130	
DOWNTOWN 300 ie 4T LC euro 3 (SK60)	5217041	5217362	7717027B	---	---	---	152	SPORT
DOWNTOWN 300 ie 4T LC euro 3 (SK60)	5217041	5217420	7715900B	---	---	---	153	MHR
DOWNTOWN 300 ie 4T LC euro 3 2012-> (SK60A)	5217041	5217362	7717027B	---	---	---	152	SPORT
DOWNTOWN 300 ie 4T LC euro 3 2012-> (SK60A)	5217041	5217420	7715900B	---	---	---	153	MHR
DOWNTOWN i ABS 350 ie 4T LC euro 3 (SK64)	5217041	5217362	7717027B	---	---	---	152	SPORT
DOWNTOWN i ABS 350 ie 4T LC euro 3 (SK64)	5217041	5217420	7715900B	---	---	---	153	MHR
G-DINK 125 ie 4T LC euro 3 (SP25)	5217088B	5217363	7717083B	---	---	---	130	
G-DINK 300 ie 4T LC euro 3 (SH60)	---	---	---	5211467	---	---	135	
GRAND DINK 250 4T LC	5217041	5217362	7717027B	---	---	---	152	SPORT
GRAND DINK 250 4T LC	5217041	5217420	7715900B	---	---	---	153	MHR
K-XCT 125 ie 4T LC euro 3	5217088B	5217363	7717083B	---	---	---	130	
K-XCT 300 ie 4T LC euro 3	5217041	5217362	7717027B	---	---	---	152	SPORT
K-XCT 300 ie 4T LC euro 3	5217041	5217420	7715900B	---	---	---	153	MHR
LIKE 125 4T euro 3 (KA40)	5212522	5214724	7714325	5212487	---	---	125	
LIKE 200 ie 4T euro 3 (KA40)	5212522	5214724	7714325	5212487	---	---	125	

(*) : for clutch bell Ø

(N) : ATTENTION * ONLY FOR vehicles CIRCULATING in: INDONESIA - SINGAPORE - THAILAND - VIETNAM

New**MALOSS**

Applications	MAXI FLY SYSTEM			MAXI DELTA SYSTEM			(*)	N.B.
	clutch	clutch BELL	clutch BELL	clutch	clutch BELL	clutch BELL		
MOVIE 125 4T euro 3	5212522	5214724	7714325	5212487	---	---	125	
PEOPLE - PEOPLE S 125 4T euro 3	5212522	5214724	7714325	5212487	---	---	125	
PEOPLE GTi 125 ie 4T LC euro 3 (BF25)	5217088B	5217363	7717083B	---	---	---	130	
PEOPLE One 125 ie 4T euro 3 (KM25)	5212522	5214724	7714325	5212487	---	---	125	
PEOPLE 150 4T	5212522	5214724	7714325	5212487	---	---	125	
PEOPLE S 200 4T (BA 40)	5212522	5214724	7714325	5212487	---	---	125	
PEOPLE - PEOPLE S 250 4T LC euro 2	5217041	5217362	7717027B	---	---	---	152	SPORT
PEOPLE - PEOPLE S 250 4T LC euro 2	5217041	5217420	7715900B	---	---	---	153	MHR
PEOPLE GTi 300 ie 4T LC euro 3 (BF60)	5217041	5217362	7717027B	---	---	---	152	SPORT
PEOPLE GTi 300 ie 4T LC euro 3 (BF60)	5217041	5217420	7715900B	---	---	---	153	MHR
PEOPLE S 300 ie 4T LC euro 3 (BB60)	---	---	7715900B	---	---	---	153	
SUPER 8 125 4T euro 3 (KL25)	5212522	5214724	7714325	5212487	5216070	7713376	125	
SUPER DINK 125 ie 4T LC euro 3 (SK25)	5217088B	5217363	7717083B	---	---	---	130	
SUPER DINK 300 ie 4T LC euro 3 (SK60)	5217041	5217362	7717027B	---	---	---	152	SPORT
SUPER DINK 300 ie 4T LC euro 3 (SK60)	5217041	5217420	7715900B	---	---	---	153	MHR
SUPER DINK 300 ie 4T LC euro 3 2012-> (SK60A)	5217041	5217362	7717027B	---	---	---	152	SPORT
SUPER DINK 300 ie 4T LC euro 3 2012-> (SK60A)	5217041	5217420	7715900B	---	---	---	153	MHR
VIVIO 125 - 150 4T	5212522	5214724	7714325	5212487	---	---	125	
XCITING 250 4T LC euro 2	5217041	5217362	7717027B	---	---	---	152	SPORT
XCITING 250 4T LC euro 2	5217041	5217420	7715900B	---	---	---	153	MHR
XCITING - XCITING R 300 ie 4T LC euro 3	5217041	5217362	7717027B	---	---	---	152	SPORT
XCITING - XCITING R 300 ie 4T LC euro 3	5217041	5217420	7715900B	---	---	---	153	MHR
XCITING 500 4T LC euro 2-3	5213333	---	---	---	---	---	160	
XCITING R 500 ie 4T LC euro 3 (SB A0)	5213333	---	---	---	---	---	160	
YAGER GT 200 ie 4T LC euro 3 (SJ40)	5217088B	5217363	7717083B	---	---	---	130	
YAGER GT 300 ie 4T LC euro 3 (SH60)	---	---	---	5211467	---	---	135	
YUP 250 4T LC (SH 50 D)	5217041	5217362	7717027B	---	---	---	152	SPORT
YUP 250 4T LC (SH 50 D)	5217041	5217420	7715900B	---	---	---	153	MHR
MALAGUTI BLOG 125 ie 4T LC euro 3 (03)	5212522	5214724	7714325	5212487	5216070	7713376	125	
BLOG 160 ie 4T LC euro 3 (04)	5212522	5214724	7714325	5212487	5216070	7713376	125	
CENTRO 125 ie 4T LC euro 3	5212522	5214724	7714325	5212487	---	---	125	
CENTRO 160 ie 4T LC euro 3 (02)	5212522	5214724	7714325	5212487	---	---	125	
CIAK MASTER 125 - 150 4T	5212522	5214724	7714325	5212487	---	---	125	
CIAK MASTER 200 4T	5212522	5214724	7714325	5212487	---	---	125	
MADISON 125 4T LC (YAMAHA)	---	---	7714335	---	---	---	120	
MADISON 3 125 4T LC (PIAGGIO)	---	---	---	5211821	5216918	7715898B	134	
MADISON 150 4T LC (YAMAHA)	---	---	---	5211888	5217406	7713368	135	
MADISON 180 4T LC (PIAGGIO)	---	---	---	5211821	5216918	7715898B	134	
MADISON 200 4T LC (PIAGGIO)	---	---	---	5211821	5216918	7715898B	134	
MADISON 250 4T LC (YAMAHA)	---	---	---	5211468	5217405	7713368	135	
MADISON 3 250 4T LC (PIAGGIO)	---	---	---	5211821	5216918	7715898B	134	
MADISON RS 250 4T LC (PIAGGIO M237M)	---	---	---	5211821	5216918	7715898B	134	
MADISON K 400 4T LC	---	---	7714329	---	---	---	150	
PassWord CK 250 4T LC	---	---	---	5211835	5214721	7713369	145	
PHANTOM MAX 200 4T LC (PIAGGIO)	---	---	---	5211821	5216918	7715898B	134	
PHANTOM MAX 250 4T LC (PIAGGIO M361M)	---	---	---	5211821	5216918	7715898B	134	
SPIDERMAX GT 500 4T LC (PIAGGIO M341M)	5212813	5216202	7715579B	---	---	---	160	
MBK CITYLINER 125 ie 4T LC euro 3	---	---	---	5211888	5217406	7713368	135	
DOODO 125 4T LC	5212544	5214727	7714335	5212450	---	---	120	
DOODO 150 4T LC	---	---	---	5211888	5217406	7713368	135	
EVOLIS 250 ie 4T LC euro 3 2014->	---	---	---	5211835	5214721	7713369	145	
EVOLIS 400 ie 4T LC euro 3	5212819	5216331	7715582B	---	---	---	160	
KILBRE 300 4T LC (H314E)	---	---	---	5211835	5214721	7713369	145	
OCITO 125 ie 4T LC euro 3	5212522	---	---	5212487	---	---	125	
SKYCRUISER 125 ie 4T LC euro 3	---	---	---	5211888	5217406	7713368	135	
SKYLINER 125 4T LC	5212544	5214727	7714335	5212450	---	---	120	
SKYLINER 150 4T LC	---	---	---	5211888	5217406	7713368	135	
SKYLINER 250 4T LC	---	---	---	5211835	5214721	7713369	145	
THUNDER 125 4T LC	5212544	5214727	7714335	5212450	---	---	120	
THUNDER 150 4T LC	---	---	---	5211888	5217406	7713368	135	
X OVER 125 ie 4T euro 3 (E3G3E)	5212544	5214727	7714335	5212450	---	---	120	
OVER THOR 125 4T euro 3 (LJ1P52QMI)	5212522	---	---	5212487	5216070	7713376	125	
PEUGEOT GEOPOLIS 125 ie 4T LC euro 3	---	---	---	5211821	---	---	134	
GEOPOLIS 250 ie 4T LC euro 3	---	---	---	5211821	---	---	134	
GEOPOLIS R/GT 300 ie 4T LC euro 3	---	---	---	5211821	5216918	7715898B	134	
GEOPOLIS 400 4T LC euro 3	5212813	5216202	7715579B	---	---	---	160	
GeoRS 300 ie 4T LC euro 3 (PIAGGIO M28MM)	---	---	---	5211821	5216918	7715898B	134	

(*) : for clutch bell Ø

(N) : ATTENTION * ONLY FOR vehicles CIRCULATING in: INDONESIA - SINGAPORE - THAILAND - VIETNAM

New



MALOSSI

Applications	MAXI FLY SYSTEM			MAXI DELTA SYSTEM			(*)	N.B.
	clutch		clutch BELL	clutch		clutch BELL		
JET FORCE 125 4T LC euro 3	---	---	---	5211821	---	---	134	
LXR 125 4T LC euro 3 (MB)	5212522	---	---	5212487	5216070	7713376	125	
LXR 200 ie 4T LC euro 3	---	---	7714325	---	---	---	125	
METROPOLIS 400 ie 4T LC euro 3 (P6A)	5212813	---	---	---	---	---	160	
SATELIS 125 4T LC euro 3 (FD6)	---	---	---	5211821	---	---	134	
SATELIS compressor 125 4T LC euro 3 (FD6S)	---	---	---	5211835	---	---	145	
SATELIS 250 4T LC euro 3	---	---	---	5211821	---	---	134	
SATELIS 400 4T LC euro 3 <-2014 (PIAGGIO)	5212813	5216202	7715579B	---	---	---	160	
SATELIS 400 4T LC euro 3 2015->	5212813	---	---	---	---	---	160	
SATELIS RS 400 4T LC euro 3 2015->	5212813	---	---	---	---	---	160	
SATELIS 500 4T LC euro 3	5212813	5216202	7715579B	---	---	---	160	
SV 250 4T LC	---	---	---	5211467	5216184	7715916B	135	
TWEET 125 4T euro 3	5212522	---	---	5212487	5216070	7713376	125	
PIAGGIO BEVERLY 125 4T LC <-2009	---	---	---	5211821	5216918	7715898B	134	
BEVERLY 125 ie 4T LC euro 3 2010-> (QUASAR)	---	---	---	5211821	5216918	7715898B	134	
BEVERLY 200 4T LC	---	---	---	5211821	5216918	7715898B	134	
BEVERLY 250 4T LC euro 1-2 (M285M)	---	---	---	5211821	5216918	7715898B	134	
BEVERLY 250 ie 4T LC euro 3	---	---	---	5211821	5216918	7715898B	134	
BEVERLY S 250 ie 4T LC euro 3	---	---	---	5211821	5216918	7715898B	134	
BEVERLY 300 ie 4T LC euro 3	---	---	---	5211821	5216918	7715898B	134	
BEVERLY TOURER 300 ie 4T LC euro 3	---	---	---	5211821	5216918	7715898B	134	
BEVERLY 400 ie 4T LC euro 3 (M345M)	5212813	5216202	7715579B	---	---	---	160	
BEVERLY TOURER 400 ie 4T LC euro 3 (M345M)	5212813	5216202	7715579B	---	---	---	160	
BEVERLY 500 ie 4T LC euro 2-3	5212813	5216202	7715579B	---	---	---	160	
BEVERLY CRUISER 500 ie 4T LC euro 3	5212813	5216202	7715579B	---	---	---	160	
CARNABY 125 4T LC euro 3 (LEADER M28FM)	---	---	---	5211821	5216918	7715898B	134	
CARNABY 200 4T LC euro 3 (LEADER M601M)	---	---	---	5211821	5216918	7715898B	134	
CARNABY 300 ie 4T LC euro 3 (QUASAR)	---	---	---	5211821	5216918	7715898B	134	
FLY 125 4T euro 2-3 (LEADER M422M)	---	---	---	5211821	5216918	7715898B	134	
NEW FLY 3V 125 ie 4T euro 3 2012->	---	---	---	5216462	5216569	7715647	134	
NEW FLY 3V 125 ie 4T euro 3 2012->	5217058B	---	7715648	---	---	---	125	(N)
FLY 150 4T euro 2-3 (LEADER M422M)	---	---	---	5211821	5216918	7715898B	134	
HEXAGON 125 2T LC	5212840	---	---	5211481	---	---	134	
HEXAGON LX 125 2T LC	5212840	---	---	5211481	---	---	134	
SUPER HEXAGON GTX 125 4T LC	---	---	---	5211821	5216918	7715898B	134	
HEXAGON 150 2T LC	5212840	---	---	5211481	---	---	134	
HEXAGON LXT 180 2T LC	5212840	---	---	5211481	---	---	134	
SUPER HEXAGON GTX 180 4T LC	---	---	---	5211821	5216918	7715898B	134	
LIBERTY - LIBERTY LE 125 - 150 4T euro 1-2 (LEADER)	---	---	---	5211821	5216918	7715898B	134	
LIBERTY 125 - 150 4T euro 3 (LEADER)	---	---	---	5211821	5216918	7715898B	134	
LIBERTY S 125 4T euro 3 (LEADER M381M)	---	---	---	5211821	5216918	7715898B	134	
LIBERTY 3V 125 ie 4T euro 3	5217058B	---	7715648	---	---	---	125	
LIBERTY iGet ABS 125 ie 4T euro 3 (M893M)	5217058B	---	7715648	---	---	---	125	
LIBERTY iGet ABS 150 ie 4T euro 3	5217058B	---	7715648	---	---	---	125	
LIBERTY 3V 150 ie 4T euro 3 (M738M)	---	---	---	5216462	5216569	7715647	134	
LIBERTY - LIBERTY S 200 4T euro 3 (LEADER)	---	---	---	5211821	5216918	7715898B	134	
MEDLEY 125 ie 4T LC euro 4 (MA01M)	---	---	---	5216462	5217490	7717430B	134	
MEDLEY 150 ie 4T LC euro 4	---	---	---	5216462	5217490	7717430B	134	
MP3 125 4T LC euro 3 (LEADER)	---	---	---	5211821	5216918	7715898B	134	
MP3 YOURBAN 4V 125 ie 4T LC euro 3 2011->	---	---	---	5211821	5216918	7715898B	134	
MP3 250 ie 4T LC euro 3 (QUASAR M472M)	---	---	---	5211821	5216918	7715898B	134	
MP3 300 ie 4T LC euro 3 (QUASAR M634M)	---	---	---	5211821	5216918	7715898B	134	
MP3 300 ie 4T LC euro 3 2014-> (M862M)	---	---	---	5211821	5216918	7715898B	134	
MP3 YOURBAN 4V 300 ie 4T LC euro 3 2011->	---	---	---	5211821	5216918	7715898B	134	
MP3 400 ie 4T LC euro 3 (MASTER M474M)	5212813	5216202	7715579B	---	---	---	160	
MP3 500 ie 4T LC euro 3	5212813	5216202	7715579B	---	---	---	160	
SKIPPER 125 - 150 2T	5212840	---	---	5211481	---	---	134	
SKIPPER LX 125 2T	5212840	---	---	5211481	---	---	134	
SKIPPER ST 125 - 150 4T (LEADER)	---	---	---	5211821	5216918	7715898B	134	
SKIPPER LXT 150 2T	5212840	---	---	5211481	---	---	134	
TYPHOON 125 4T euro 3 (LEADER M701M)	---	---	---	5211821	5216918	7715898B	134	
X7 125 4T LC euro 3 (LEADER)	---	---	---	5211821	5216918	7715898B	134	
X7 EVO 125 ie 4T LC euro 3 (QUASAR)	---	---	---	5211821	5216918	7715898B	134	
X7 250 ie 4T LC euro 3 (QUASAR M622M)	---	---	---	5211821	5216918	7715898B	134	
X7 EVO 300 ie 4T LC euro 3 (QUASAR)	---	---	---	5211821	5216918	7715898B	134	
X8 125 4T LC euro 2-3 (LEADER)	---	---	---	5211821	5216918	7715898B	134	
X8 200 4T LC	---	---	---	5211821	5216918	7715898B	134	

(*) : for clutch bell Ø

(N) : ATTENTION * ONLY FOR vehicles CIRCULATING in: INDONESIA - SINGAPORE - THAILAND - VIETNAM

New**MALOSSI**

Applications	MAXI FLY SYSTEM			MAXI DELTA			(*)	N.B.
	clutch	clutch BELL	clutch BELL	clutch	clutch BELL	clutch BELL		
X8 250 4T LC euro 2	---	---	---	5211821	5216918	7715898B	134	
X8 250 ie 4T LC euro 3 (QUASAR)	---	---	---	5211821	5216918	7715898B	134	
X8 400 ie 4T LC euro 3 (M521M)	5212813	5216202	7715579B	---	---	---	160	
X9 4V 125 4T LC	---	---	---	5211821	5216918	7715898B	134	
X9 4V Evolution 125 4T LC euro 2-3	---	---	---	5211821	5216918	7715898B	134	
X9 AMALFI 180 4T LC	---	---	---	5211821	5216918	7715898B	134	
X9 200 4T LC	---	---	---	5211821	5216918	7715898B	134	
X9 250 4T LC (HONDA)	---	---	---	5211467	5216184	7715916B	135	
X9 Evolution 250 4T LC (M237M)	---	---	---	5211821	5216918	7715898B	134	
X9 Evolution - Street 500 4T LC	5212813	5216202	7715579B	---	---	---	160	
X10 125 ie 4T LC euro 3	---	---	---	5211821	5216918	7715898B	134	
X10 500 ie 4T LC euro 3	5212813	5216202	7715579B	---	---	---	160	
XEvo 125 4T LC euro 3 (LEADER)	---	---	---	5211821	5216918	7715898B	134	
XEvo 250 ie 4T LC euro 3 (QUASAR)	---	---	---	5211821	5216918	7715898B	134	
XEvo 400 ie 4T LC euro 3 (M521M)	5212813	5216202	7715579B	---	---	---	160	
ZIP 125 4T (LEADER)	---	---	---	5211821	5216918	7715898B	134	
QUADRO 3 350 ie 4T LC euro 3 2016 (T69N)	5217041	5217362	7717027B	---	---	---	152	SPORT
3 350 ie 4T LC euro 3 2016 (T69N)	5217041	5217420	7715900B	---	---	---	153	MHR
RENAULT FULLTIME 125 4T (LEADER)	---	---	---	5211821	5216918	7715898B	134	
SUZUKI BURGMAN AN 250 4T LC	---	---	---	5211887	---	---	130	
BURGMAN AN - Business 400 4T LC	5213060	5217404	7714329	---	---	---	150	
BURGMAN AN 400 ie 4T LC <-2007 (K429)	5213060	5217404	7714329	---	---	---	150	
BURGMAN AN K 7 > 400 ie 4T LC	5213296	5216181	7715576B	---	---	---	160	
SYM CITYCOM 300 4T LC euro 3 (LEA 1)	---	---	---	5211835	---	---	145	
FIDDLE III W4 125 4T euro 3 (XS1P52QMI-3B)	5212522	---	---	5212487	5216070	7713376	125	
GTS I 250 ie 4T LC euro 3	---	---	---	5211835	---	---	145	
GTS Evo I 300 ie 4T LC euro 3 (MK8)	---	---	---	5211835	---	---	145	
HD Evo I 125 ie 4T LC euro 3	5212522	---	---	5212487	5216070	7713376	125	
HD Evo I 200 ie 4T LC euro 3 (HHA-1)	---	---	7714325	---	---	---	125	
JOYMAX I 250 ie 4T LC euro 3 (HMA-1)	---	---	---	5211835	---	---	145	
JOYMAX I 300 ie 4T LC euro 3 (MK915096)	---	---	---	5211835	---	---	145	
JOYMAX Evo I 300 ie 4T LC euro 3 (MK8)	---	---	---	5211835	---	---	145	
JOYRIDE 150 4T LC	---	---	7714325	---	---	---	125	
JOYRIDE Evo I 200 ie 4T LC (KB2)	---	---	7714325	---	---	---	125	
SYMPHONY S 125 4T euro 3 (XS1P52QMI-4)	5212522	---	---	5212487	5216070	7713376	125	
SYMPHONY ST W4 125 4T euro 3 (XS1P52QMI-3B)	5212522	---	---	5212487	5216070	7713376	125	
TGB X MOTION 250 4T LC	---	---	---	5211835	---	---	145	
VESPA 946 3V ABS 125 ie 4T (M801M)	---	---	---	5216462	5216569	7715647	134	
ET4 125 - 150 4T (LEADER)	---	---	---	5211821	5216918	7715898B	134	
Granturismo L - GT 125 4T LC (LEADER)	---	---	---	5211821	5216918	7715898B	134	
Granturismo L - GT 200 4T LC (M312M)	---	---	---	5211821	5216918	7715898B	134	
GTS 125 4T LC euro 3 (M315M)	---	---	---	5211821	5216918	7715898B	134	
GTS Super 125 ie 4T LC euro 3	---	---	---	5211821	5216918	7715898B	134	
GTS 250 ie 4T LC	---	---	---	5211821	5216918	7715898B	134	
GTS Super 300 ie 4T LC euro 3 (QUASAR)	---	---	---	5211821	5216918	7715898B	134	
GTV 125 4T LC (LEADER)	---	---	---	5211821	5216918	7715898B	134	
GTV 250 ie 4T LC	---	---	---	5211821	5216918	7715898B	134	
GTV 300 ie 4T LC euro 3 (QUASAR)	---	---	---	5211821	5216918	7715898B	134	
LX 125 - 150 4T (LEADER)	---	---	---	5211821	5216918	7715898B	134	
LX 125 ie 4T euro 3 (LEADER)	---	---	---	5211821	5216918	7715898B	134	
LX 125 ie 4T euro 3 (LEADER)	5217058B	---	7715648	---	---	---	125	(N)
LX 3V 125 ie 4T euro 3 2012-> (M687M)	---	---	---	5216462	5216569	7715647	134	
LX 3V 125 ie 4T euro 3 2012-> (M687M)	5217058B	---	7715648	---	---	---	125	(N)
LX 150 ie 4T euro 3 (LEADER)	---	---	---	5211821	5216918	7715898B	134	
LX 3V 150 ie 4T euro 3 2012-> (M688M)	---	---	---	5216462	5216569	7715647	134	
LXV 125 ie 4T euro 3 (LEADER)	---	---	---	5211821	5216918	7715898B	134	
LXV 125 ie 4T euro 3 (LEADER)	5217058B	---	7715648	---	---	---	125	(N)
Primavera 3V 125 ie 4T euro 3 2014-> (M811M)	5217058B	---	7715648	---	---	---	125	
Primavera 3V 150 ie 4T euro 3 2014-> (M812M)	---	---	---	5216462	5216569	7715647	134	
S 125 - 150 4T euro 3 (LEADER)	---	---	---	5211821	5216918	7715898B	134	
S 3V 125 ie 4T euro 3 2012->	---	---	---	5216462	5216569	7715647	134	
S 3V 125 ie 4T euro 3 2012->	5217058B	---	7715648	---	---	---	125	(N)
Sprint 3V 125 ie 4T euro 3 2014->	5217058B	---	7715648	---	---	---	125	
Sprint 3V 150 ie 4T euro 3 2014->	---	---	---	---	---	7715647	134	
WT MOTORS ATENE 152 4T LC (1P58MJA)	5212522	5214724	7714325	5212487	---	---	125	
MIAMI 250 4T LC (172MM)	---	---	---	5211467	5216184	7715916B	135	

(*) : for clutch bell Ø

(N) : ATTENTION * ONLY FOR vehicles CIRCULATING in: INDONESIA - SINGAPORE - THAILAND - VIETNAM

New



MALOSSI

471

52 CLUTCH SYSTEM

Applications	MAXI FLY SYSTEM			MAXI DELTA SYSTEM			(*)	N.B.
	clutch	clutch BELL	clutch BELL	clutch	clutch BELL	clutch BELL		
YAMAHA BW'S 125 ie 4T euro 3 (E3G3E)	5212544	5214727	7714335	5212450	---	---	120	
CYGNUS X 125 4T	5212544	5214727	7714335	5212450	---	---	120	
CYGNUS X 125 ie 4T euro 3	5212544	5214727	7714335	5212450	---	---	120	
MAJESTY 125 4T LC	5212544	5214727	7714335	5212450	---	---	120	
MAJESTY 150 4T LC	---	---	---	5211888	5217406	7713368	135	
MAJESTY 180 4T LC	---	---	---	5211888	5217406	7713368	135	
MAJESTY 250 4T LC <-1999	---	---	---	5211468	5217405	7713368	135	
MAJESTY 250 4T LC 2000->	---	---	---	5211835	5214721	7713369	145	
MAJESTY 400 4T LC <-2008 (H317E)	5212819	5216331	7715582B	---	---	---	160	
MAJESTY 400 4T LC euro 3 2009-> (H322E)	5212819	5216331	7715582B	---	---	---	160	
MAXSTER 125 4T LC	5212544	5214727	7714335	5212450	---	---	120	
MAXSTER 150 4T LC	---	---	---	5211888	5217406	7713368	135	
N MAX 125 ie 4T LC euro 3 (E353E)	5212522	---	---	5212487	---	---	125	
N MAX 150 ie 4T LC euro 3	5212522	---	---	5212487	---	---	125	
TEO'S 125 4T LC	5212544	5214727	7714335	5212450	---	---	120	
TEO'S 150 4T LC	---	---	---	5211888	5217406	7713368	135	
VERSITY XC 300 4T LC (H314E)	---	---	---	5211835	5214721	7713369	145	
X CITY 125 ie 4T LC euro 3 (E3A5E)	---	---	---	5211888	5217406	7713368	135	
X CITY 250 ie 4T LC euro 3 (G358E)	---	---	---	5211835	5214721	7713369	145	
X CITY 250 ie 4T LC euro 3 2014-> (G3B7E)	---	---	---	5211835	5214721	7713369	145	
ZUMA 125 ie 4T euro 3	5212544	5214727	7714335	5212450	---	---	120	
X MAX 125 ie 4T LC euro 3	---	---	---	5211888	5217406	7713368	135	
X MAX 250 4T LC	---	---	---	5211835	5214721	7713369	145	
X MAX 250 ie 4T LC euro 3	---	---	---	5211835	5214721	7713369	145	
X MAX 400 ie 4T LC euro 3 (H330E)	5212819	5216331	7715582B	---	---	---	160	
ATV - QUAD								
AIE MAGMAX 275 4T LC (FBGM)	---	---	---	5211835	---	---	145	
PGO BUG RACER 500 4T LC (PIAGGIO)	5212813	5216202	7715579B	---	---	---	160	
WT MOTORS KAYMAN WT 150 4T (P57QMJ)	5212522	---	---	5212487	---	---	125	

5211467	€ 129,23	5212492	€ 104,00	5213333	€ 146,14	5216569	€ 135,00	5217406	€ 125,46	7715579B	€ 49,00
5211468	€ 129,23	5212522	€ 70,37	5214721	€ 137,70	5216918	€ 136,00	5217420	€ 175,00	7715582B	€ 60,00
5211481	€ 120,42	5212539	€ 70,37	5214724	€ 83,00	5217040	€ 112,49	New 5217490	€ 137,70	7715647	€ 44,29
5211553	€ 120,42	5212544	€ 70,37	5214727	€ 89,00	5217041	€ 146,14	7713368	€ 59,00	7715648	€ 38,00
5211821	€ 120,42	5212813	€ 146,14	5216070	€ 125,46	5217058B	€ 70,37	7713369	€ 56,50	7715898B	€ 53,04
5211835	€ 128,41	5212819	€ 146,14	5216181	€ 175,00	5217088B	€ 70,37	7713376	€ 39,14	7715900B	€ 59,00
5211887	€ 129,23	5212823	€ 146,14	5216184	€ 136,00	5217362	€ 165,00	7714325	€ 33,00	7715916B	€ 53,04
5211888	€ 120,42	5212840	€ 81,20	5216202	€ 149,94	5217363	€ 110,00	7714329	€ 124,20	7717027B	€ 52,00
5212450	€ 112,59	5213060	€ 146,14	5216331	€ 165,00	5217404	€ 238,00	7714335	€ 41,00	7717083B	€ 60,00
5212487	€ 112,59	5213296	€ 146,14	5216462	€ 120,42	5217405	€ 137,70	7715576B	€ 70,00	New 7717430B	€ 52,00

(*) : for clutch bell Ø

(N) : ATTENTION * ONLY FOR vehicles CIRCULATING in: INDONESIA - SINGAPORE - THAILAND - VIETNAM



CODE	PRICE	INTERNAL Ø mm	EXTERNAL Ø mm	WIDHT mm
6613484B	€ 12,50	10	13	14,3
66 3974B	€ 6,89	10	13	14,5
6616783B	€ 9,26	10	14	13
66 3973B	€ 9,48	12	15	15
6612961B	€ 9,95	12	15	16,6
66 4151B	€ 8,36	12	15	17,5
66 8102B	€ 10,45	12	16	16
6611785B	€ 9,95	12	17	16
66 3276B	€ 8,86	13	16	14
6615509B	€ 15,50	13	17	17,7
66 7169B	€ 9,00	15	18	14
66 5839B	€ 12,00	16	21	10
66 8898B	€ 10,06	16	20	20
66 6004B	€ 18,50	16	22	23
66 8897B	€ 20,50	20	26	15

2 RADIAL BALL BEARINGS for crankshaft

Rigid radial ball bearings with oversized spherical rollers and increased operating load, developed for racing endothermic engines with higher power than 30 Kw and speed up to 18.000/20.000 RPM. In co-operation with Malossi Engineering R&D department, SKF optimized a new kind of special bearings for two and four stroke scooters and motorcycles competing in the Malossi Trophy series. Technicians and field specialists welcomed with enthusiasm this further technical progress, which guarantees higher reliability and performance increase.

Technical Specifications

- Material: high quality 100Cr6 steel alloy
- Polyamide spherical roller cages: light, noiseless, with lowest damping factor
- High precision: C3 H – C4 H tolerances
- Art. 6614105EA – Ø 20x52x12 special roller bearing for tuned scooters based on Piaggio 50 cc., with carbonitrided inner ring, polyamide cage and special outer ring, further modified by Malossi in order to improve lubrication.



CODE	PRICE	INTERNAL Ø mm	EXTERNAL Ø mm	INTERNAL RING HEIGHT mm	EXTERNAL RING HEIGHT mm	CAGE MATERIALS	BALLS Ø	RADIAL INTERNAL CLEARANCE	NOTE
6614423E	€ 33,66	17	47	14	14	Polyamide	9.525	C3	-
6611566E	€ 19,00	20	47	14	14	Polyamide	9.525	C3H	-
6615137E	€ 19,00	20	47	14	14	Polyamide	9.525	C4H	-
6614105EA	€ 82,00	20	52	12	10.8	Polyamide	7.938	C3M	MHR (*)
6614105E	€ 43,00	20	52	12	12	Polyamide	7.938	C3M	-

(*) : with A NARROWER EXTERNAL RING for a BETTER OIL FLOW.

Technical specifications according to size

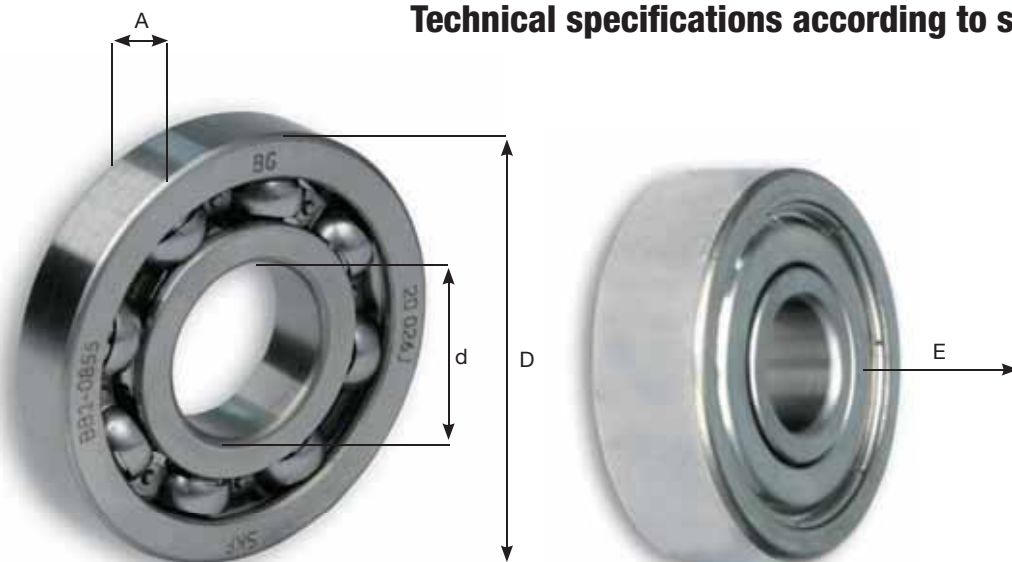

New

SIZE		TYPE	Ø BALL	CLEARANCE	SHIELDED	CAGE	CODE	NOTE	PRICE
d	D								
7	19	6	BALLS	3	STD	(2RSH)	STEEL	66 6758B	S € 7,04
8	24	8	BALLS	3,968	STD	(2Z)	STEEL	6614373B	S € 19,00
10	30	9	BALLS	4,762	STD	-	POLYAMIDE	6615713B	S € 8,00
12	24	6	BALLS	3,175	STD	(2RS1)	STEEL	66 8835B	S € 9,00
15	32	8	BALLS	4,762	STD	-	STEEL	6614144B	S € 12,00
15	32	9	BALLS	4,762	STD	(Z)	STEEL	6611856B	S € 8,50
15	32	9	BALLS	4,762	STD	-	STEEL	6611735B	S € 6,30
15	32	9	BALLS	4,762	STD	(2RS1)	POLYAMIDE	66 9447B	S € 8,50
15	35	11	BALLS	6	STD	-	STEEL	66 4678B	S € 8,93
16	22	12	ROLLER	2	STD	-	STEEL	6615717B	S € 11,00
17	35	10	BALLS	4,762	STD	(Z)	POLYAMIDE	6611518B	S € 7,16
17	40	12	BALLS	6,747	C4	-	POLYAMIDE	6616266B	S € 14,30
17	47	14	BALLS	9,525	C3	-	POLYAMIDE	6614423B	S € 17,00
20	42	12	BALLS	6,35	C3	-	POLYAMIDE	6614630B	S € 8,50
20	42	12	BALLS	6,35	STD	-	STEEL	6611855B	S € 8,00
20	47	12,7	BALLS	7,938	C4	-	POLYAMIDE	6616334E	C - (J) € 48,00
20	47	14	BALLS	9,525	C3H	-	POLYAMIDE	6611566B	S € 9,60
20	47	14	BALLS	9,525	C4H	-	POLYAMIDE	6615137E	C € 19,00
20	47	14	BALLS	9,525	C3	(2RSH)	POLYAMIDE	6616102B	S € 13,00
20	47	14	BALLS	7,938	C4	-	POLYAMIDE	6616065B	S - (X) € 14,00
20	47	14	ROLLER	7,5	C3	-	POLYAMIDE	6615711B	S € 46,00
20	52	12	BALLS	7,938	C3M	-	POLYAMIDE	6614105E	C € 43,00
20	52	10-12	BALLS	7,938	C3M	-	POLYAMIDE	6614105EA	C - (K) € 82,00
24	32	16	ROLLER	2,5	STD	-	POLYAMIDE	6614581B	S € 19,50
25	38	15	ROLLER	2,5	STD	-	POLYAMIDE	6615445B	S € 21,30
25	47	8	BALLS	5	STD	-	STEEL	6615714B	S € 12,70
25	47	12	BALLS	6,747	STD	-	STEEL	6611519B	S € 7,72
25	52	15	ROLLER	9	C3	-	POLYAMIDE	6615990B	S € 28,00
25	62	12	BALLS	10,319	C4	-	STEEL	6615463B	S € 33,00
25	62	12	BALLS	10,319	C4	-	STEEL	6615384B	S - (W) € 40,00

(X) = Carbonitrided inner ring.

(W) = Carbonitrided inner ring and oversize balls.

(K) = Carbonitrided inner ring, oversize balls and special reduced outer ring.

(J) = Carbonitrided inner ring and special reduced outer ring.

S = Single.

C = Pair.

(Z) = Metal shield on one side of the bearing.

(2Z) = Metal shield on both sides of the bearing.

(2RS1) = Rubber seal (nbr) with a sheet steel reinforcement on both sides of the bearing.

(2RSH) = Rubber seal (nbr) with a sheet steel reinforcement on both sides of the bearing (like 2RS1 but it has a different way of fitting the seal into the bearing)

New**MALOSSI**

Special high-precision bearings

High-speed bearings with increased load capacity, designed and tested for endothermic racing engines.

Special high-speed precision bearings, reinforced for increased load and heavy applications, with oversize balls, carbonitrided inner rings, steel and polyamide cages. The co-operation of Malossi technicians with the company SKF allowed to obtain an important technical result for the fine-tuning of high-quality racing engines.

Above all, we would like to point out bearing art. **6614105EA**, since it features - besides the carbonitrided ring - reinforced load capacity, polyamide cage and reduced outer ring tolerance. This last modification was made by Malossi technicians to achieve a better lubrication of the ball guides. In order to check the suggested application, please see the below chart, based on the results of severe tests performed by Malossi technicians both tracks. The column of technical specifications bears an abbreviation which indicates the main technical features of each bearing.



CRANKSHAFT BEARINGS

	SIZE	TYPE	Ø BALL	CLEARANCE	CAGE	CODE	PRICE
--	------	------	--------	-----------	------	------	-------

MINARELLI AM 3 - 4 - 5 - 6 MOTO

1 BEARING	17x47x14	BALLS	9,525	C3	POLYAM.	6614423B	€ 17,00
2 BEARINGS	17x47x14	BALLS	9,525	C3	POLYAM.	6614423E	€ 33,66

DERBI 50 MOTO

1 BEARING	20x47x14	BALLS	9,525	C3H	POLYAM.	6611566B	€ 9,60
2 BEARINGS	20x47x14	BALLS	9,525	C3H	POLYAM.	6611566E	€ 19,00
2 BEARINGS	20x47x14	BALLS	9,525	C4H	POLYAM.	6615137E	€ 19,00
1 BEARING	20x47x14	X BALLS	7,938	C4	POLYAM.	6616065B	€ 14,00
2 BEARINGS	20x47x14	X BALLS	7,938	C4	POLYAM.	6616065E	€ 27,72

MINARELLI - YAMAHA 50 SCOOTER

1 BEARING	20x47x14	X BALLS	7,938	C4	POLYAM.	6616065B	€ 14,00
2 BEARINGS	20x47x14	X BALLS	7,938	C4	POLYAM.	6616065E	€ 27,72
2 BEARINGS	20x47x14	BALLS	9,525	C4H	POLYAM.	6615137E	€ 19,00
1 BEARING	20x47x14	BALLS	9,525	C3H	POLYAM.	6611566B	€ 9,60
2 BEARINGS	20x47x14	BALLS	9,525	C3H	POLYAM.	6611566E	€ 19,00

PIAGGIO 50 SCOOTER AUTOMATIC

2 BEARINGS	20x52x10-12	K BALLS	7,938	C3M	POLYAM.	6614105EA	€ 82,00
2 BEARINGS	20x52x12	BALLS	7,938	C3M	POLYAM.	6614105E	€ New 43,00

PIAGGIO - CIAO - BRAVO - SI - BOXER 50

1 BEARING	15X35X11	BALLS	6	STD	STEEL	66 4678B	€ 8,93
2 BEARINGS	15X35X11	BALLS	6	STD	STEEL	66 4678E	€ 17,68
1 BEARING	15X35X11	X BALLS	6	C3	STEEL	6616872B	€ 11,00
2 BEARINGS	15X35X11	X BALLS	6	C3	STEEL	6616872E	€ 21,78

X = Carbonitrided inner ring.

K = Carbonitrided inner ring, oversize balls and special reduced outer ring.



CRANKSHAFT BEARINGS



SIZE	TYPE	Ø BALL	CLEARANCE	CAGE	CODE	PRICE
------	------	--------	-----------	------	------	-------

PK 50 - PK HP 50 - PK XL 50 / SPECIAL 50 - PIAGGIO APE 50							
1 BEARING <i>Flywheel</i> SIDE	20x47x14	BALLS	9,525	C3H	POLYAM.	6611566B	€ 9,60
1 BEARING <i>Clutch</i> SIDE	17x47x14	BALLS	9,525	C3	POLYAM.	6614423B	€ 17,00
BEARING SET						6615669	€ 24,00



ET3 Primavera / PK . 125 (1 st serie)							
1 BEARING <i>Flywheel</i> SIDE	20x47x14	ROLLER	7,5	C3	POLYAM.	6615711B	€ 46,00
1 BEARING <i>Clutch</i> SIDE	17x47x14	BALLS	9,525	C3	POLYAM.	6614423B	€ 17,00
BEARING SET						6615712	€ 57,00



ETS / PK XL . 125							
1 BEARING <i>Flywheel</i> SIDE	25x38x15	ROLLER	-	STD	POLYAM.	6615445B	€ 21,30
1 BEARING <i>Clutch</i> SIDE	17x47x14	BALLS	9,525	C3	POLYAM.	6614423B	€ 17,00
BEARING SET						6615670	€ 33,00



COSA 125 > 200 / PX 80 > 200 - LML Star 125-150							
1 BEARING <i>Flywheel</i> SIDE	25x38x15	ROLLER	-	STD	POLYAM.	6615445B	€ 21,30
1 BEARING <i>Clutch</i> SIDE	25x62x12	BALLS	10,319	C4	STEEL	6615463B	€ 33,00
BEARING SET	SPORT					6615466	€ 50,00
1 BEARING <i>Flywheel</i> SIDE	25x38x15	ROLLER	-	STD	POLYAM.	6615445B	€ 21,30
1 BEARING <i>Clutch</i> SIDE	25x62x12 W	BALLS	10,319	C4	STEEL	6615384B	€ 40,00
BEARING SET	MHR					6615467	€ 56,00



T5 125							
1 BEARING <i>Flywheel</i> SIDE	25x52x15	ROLLER	9	C3	POLYAM.	6615990B	€ 28,00
1 BEARING <i>Clutch</i> SIDE	25x62x12	BALLS	10,319	C4	STEEL	6615463B	€ 33,00
BEARING SET	SPORT					6616003	€ 51,50
1 BEARING <i>Flywheel</i> SIDE	25x52x15	ROLLER	9	C3	POLYAM.	6615990B	€ 28,00
1 BEARING <i>Clutch</i> SIDE	25x62x12 W	BALLS	10,319	C4	STELL	6615384B	€ 40,00
BEARING SET	MHR					6616004	€ 57,50



GEAR SHAFT BEARINGS

SIZE	TYPE	Ø BALL	CLEARANCE	CAGE	CODE	PRICE
------	------	--------	-----------	------	------	-------

ET3 Primavera 125 / ETS 125 / PK 50 - 125 / SPECIAL 50							
1 BEARING	25x47x8	BALLS	5	STD	STEEL	6615714B	€ 12,70
1 BEARING <i>gearbox output</i>	10x30x9	BALLS	4,762	STD	POLYAM.	6615713B	€ 8,00
1 ROLLER SLEEVE <i>Flywheel</i> SIDE	16x22x12	ROLLER	3	STD	STEEL	6615717B	€ 11,00



W = Carbonitrided inner ring and oversize balls.

New

MALOSSI

OIL-SEAL

FKM plus PTFE



Responding to the requests of our exacting customers, Malossi proudly offers a new product line of engine oil seals for scooters, filling a void in the market.

Oil seals with special characteristics, high quality for racing, with low rotational friction and high durability. FKM plus PTFE oil seals boast the highest quality materials and advanced material technology ensuring product quality which is, as always, the driving force and pride behind Malossi.









In presenting this new product to our esteemed enthusiasts, Malossi, in the hope of achieving its desired goal, would like to thank its customer's loyalty to the brand.

Technical Characteristics

- 1)** Oil seal's body primarily constructed of a special mix of synthetic rubber and fluoropolymer elastomers (FKM).
- 2)** Support structure consists of a carbon steel armature, encapsulated with FKM.
- 3)** Internal seal design consists of an auxiliary dust lip and primary sealing lip made of PTFE, a material with a low coefficient of friction and high wear resistance.
- 4)** Stainless steel internal spring, designed to maintain constant pressure on the rotating shaft.

New



	mm	OIL-SEAL SET FKM / PTFE			
		for OVERHAUL	for CRANKSHAFT		
SCOOTER - QUAD 50 2T MINARELLI / YAMAHA					
for OVERHAUL		6615754			€ 24,00
gears cover	Ø 17x28x5	6614878B			€ 8,00
wheel axis	Ø 22x32x6	6615301B			€ 8,90
for CRANKSHAFT		6615257	6615257		€ 15,00
crankshaft (flywheel side)	Ø 20x30/34x6		6614876B		€ 8,00
crankshaft (gearbox side)	Ø 20x42/43x8/9		6614877B		€ 8,50
SCOOTER 50 2T PIAGGIO autom. - VESPA ET2 - LX - S					
for OVERHAUL		6615749			€ 24,00
gears cover	Ø 17x28x5	6614878B			€ 8,00
wheel axis	Ø 30x47x6	6615306B			€ 9,90
for CRANKSHAFT		6615256	6615256		€ 14,00
crankshaft (flywheel side)	Ø 18x28x7		6614879B		€ 8,00
crankshaft (gearbox side)	Ø 19x30x7		6614880B		€ 8,00
MOTO 50 DERBI / PIAGGIO					
for OVERHAUL		6615753			€ 20,00
gearbox output	Ø 17x35x7	6615297B			€ 8,90
for CRANKSHAFT		6615300E	6615300E		€ 14,00
crankshaft (flywheel side)	Ø 20x35x7		6615300B		€ 8,90
crankshaft (gearbox side)	Ø 20x35x7		6615300B		€ 8,90
MINARELLI / YAMAHA					
for OVERHAUL		6615757			€ 20,00
gearbox output	Ø 20x35x7	6615300B			€ 8,90
for CRANKSHAFT		6615756	6615756		€ 15,00
crankshaft (flywheel side)	Ø 17x35x8		6615298B		€ 8,90
crankshaft (gearbox side)	Ø 24x35x6		6615303B		€ 8,90
VESPA [gears] COSA - PX - T5 - LML Star					
for OVERHAUL		6615957			€ 23,50
gearbox output	Ø 30x47x6	6615306B			€ 9,90
for CRANKSHAFT		6615752	6615752		€ 16,00
crankshaft (flywheel side)	Ø 24x35x6		6615303B		€ 8,90
crankshaft (gearbox side)	Ø 31x62x5,8		6615307B		€ 9,90
ET3 125 - PK / SPECIAL (1ª serie) 50 cc					
for OVERHAUL		6615751			€ 23,00
wheel axis	Ø 27x37x7	6615305B			€ 9,90
for CRANKSHAFT		6615750	6615750		€ 15,00
crankshaft (flywheel side)	Ø 19x32x7		6615299B		€ 8,90
crankshaft (gearbox side)	Ø 22,7x47x7		6615302B		€ 9,90
ETS - PK XL 125 cc					
for OVERHAUL		6615949			€ 23,00
gearbox output	Ø 27x37x7	6615305B			€ 9,90
for CRANKSHAFT		6615948	6615948		€ 15,50
crankshaft (flywheel side)	Ø 24x35x6		6615303B		€ 8,90
crankshaft (gearbox side)	Ø 22,7x47x7		6615302B		€ 9,90
MOTORCYCLES 50 PIAGGIO CIAO - BRAVO - SI					
crankshaft (flywheel side)	Ø 15x24x5		6615296B		€ 8,90



MALOSSİ

SECONDARY GEARS HTQ

Transmission gears made of special steel with straight teeth and recalculated ratio. They completely eliminate all the axial pressures, thereby reducing stress on the bearings. They are constructed using high-precision machine, casehardened, tempered and ground to provide silent running and long life.



SECOND ROLLER GEAR for Piaggio and Gilera engines

Straight-shaved-toothed gears. Defeating friction to reduce energy consumption! With the new SECOND ROLLER GEARS, Malossi engineers aimed at reducing to a minimum the losses due to friction in the gearbox allowing the engine to transmit the most horsepower available to the rear wheel. The innovative aspect of this design lies in the addition of two roller bearings in the gearbox located at the end of the crankcase, supporting a special straight-toothed secondary shaft. This installation converts the sliding friction system due to the rotation of the shaft causing direct steel-aluminium contact (see original system) into a rolling friction system revolving around steel rollers. The advantage of this system also lies in its ease of installation: simply insert the two roller bearings, included in the Malossi SECOND ROLLER GEAR package, into their original housing.



Table of applications Piaggio and Gilera

ATTENTION : We would like to inform you that, since early 1998, Piaggio has modified the keying of the secondary drive gears in its scooters. As even Piaggio itself is not able to give any accurate and exact information on when the new gears will start to be fitted as standard on the various types of scooters, and on the engine reference numbers, currently the only possibility is to check visually the gears after disassembly. To make the task of replacing the ratio on these scooters easier, we have filled two tables: the one below organized by vehicle and the one in the following page organized by 1st SERIES, when existing, and the 2nd SERIES.

		Teeth	SECONDARY GEARS			SECOND ROLLER GEAR	
			SPLINED Ø 18	SPLINED Ø 17	PRESSED Ø 17	SPLINED Ø 18	PRESSED Ø 17
SCOOTER - MAXI SCOOTER							
ITALJET	DRAGSTER 1252t LC	z 15/41	-	67 9614	6711079	-	-
GILERA	ICE 50 2t LC	z 13/48	-	-	67 9966	-	67 9967
	RUNNER - RUNNER SP 50 2t LC	z 13/48	-	67 8938	67 9966	-	67 9967
	RUNNER 125 2t LC FX	z 15/41	-	67 9614	6711079	-	-
	RUNNER 180 2t LC FXR	z 14/43	-	-	67 9925	-	-
	STALKER 50 2t	z 13/48	-	67 8938	67 9966	-	67 9967
	STORM 50 2t	z 13/48	-	67 8938	-	67 8714	-
	TYPHOON 50 2t	z 13/48	-	67 8938	-	67 8714	-
	TYPHOON X 50 2t	z 13/48	-	-	67 9966	-	67 9967
	TYPHOON 125 2t	z 15/41	-	67 8657	-	-	-
	TYPHOON X 125 2t	z 15/41	-	-	6711079	-	-
PIAGGIO	FREE 50 2t	z 14/47	67 8717	67 8939	67 9968	-	67 9969
	HEXAGON 125- 150 2t LC	z 15/41	-	67 8657	-	-	-
	HEXAGON 125 2t LC LX	z 15/41	-	67 9614	6711079	-	-
	HEXAGON 180 2t LC LXT	z 14/43	-	-	67 9925	-	-
	LIBERTY 50 2t	z 15/55	-	-	6711135	-	-
	NRG 50 2t LC	z 13/48	-	67 8938	-	67 8714	-
	NRG 50 2t EXTREME	z 13/48	-	-	67 9966	-	67 9967
	NRG 50 2t LC EXTREME	z 13/48	-	-	67 9966	-	67 9967
	NRG 50 2t LC MC2	z 13/48	-	67 8938	67 9966	67 8714	67 9967
	NTT 50 2t LC	z 13/48	-	67 8938	-	67 8714	-
	QUARTZ 50 2t LC	z 14/47	67 8717	-	-	-	-
	SFERA 50 2t	z 14/47	67 8717	-	-	-	-
	SFERA 50 2t RESTYLING	z 13/48	-	67 8938	67 9966	-	67 9967
	SKIPPER 125 2t LX	z 15/41	-	67 9614	6711079	-	-
	SKIPPER 150 2t LXT	z 15/41	-	67 9614	6711079	-	-
	ZIP 50 2t	z 14/47	67 8717	-	-	-	67 9969
	ZIP 50 2t LC SP	z 14/47	-	67 8939	67 9968	-	67 9969
VESPA	ET2 50 2t <-1999	z 14/47	-	67 8939	67 9968	-	67 9969
	ET4 125 4t	z 14/47	-	67 8939	67 9968	-	-

67 8657 € 64,92

67 8938 € 60,41

67 9925 € 71,36

67 9968 € 61,65

6711135 € 58,86

67 8714 € 63,98

67 8939 € 60,41

67 9966 € 65

67 9969 € 71,36

6714774 € 67,32

67 8717 € 59,22

67 9614 € 68,58

67 9967 € 71,36

6711079 € 71,36

6714775 € 67,32



1st SERIES - Supposed assembly date <--1997

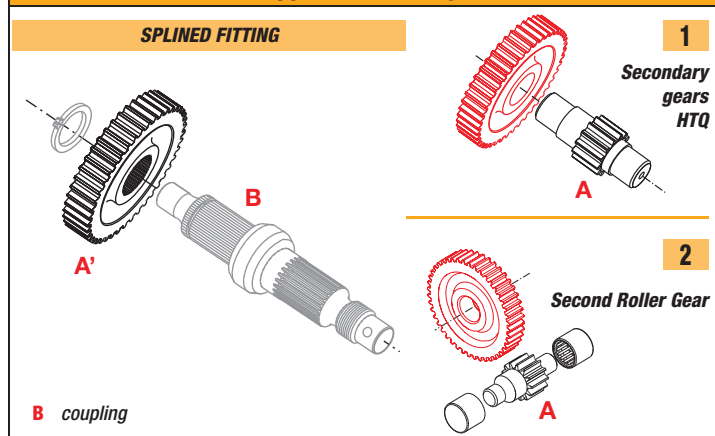

	A/A'	Art.	B Ø	Applications
SCOOTER - MAXI SCOOTER				
1	z 13/48	67 8938	17	GILERA RUNNER 50 2t LC, RUNNER SP 50 2t LC, STALKER 50 2t, STORM 50 2t, TYPHOON 50 2t PIAGGIO NRG 50 2t LC, NRG MC2 50 2t LC, NTT 50 2t LC, SFERA RESTYLING 50 2t
1	z 14/47	67 8939	17	PIAGGIO FREE 50 2t, ZIP SP 50 2t LC
		67 8717	18	VESPA ET2 50 2t <-1999, ET4 125 4t PIAGGIO FREE 50 2t, QUARTZ 50 2t LC, SFERA 50 2t, ZIP 50 2t <-1995
1	z 15/41	67 8657	17	GILERA TYPHOON 125 2t
		67 9614	17	PIAGGIO HEXAGON 125- 150 2t LC GILERA RUNNER FX 125 2t LC ITALJET DRAGSTER 125 2t LC PIAGGIO HEXAGON LX 125 2t LC, SKIPPER LX 125 2t, SKIPPER LXT 150 2t
2	z 13/48	67 8714	18	SCOOTER GILERA STORM 50 2t, TYPHOON 50 2t PIAGGIO NRG 50 2t LC, NRG MC2 50 2t LC, NTT 50 2t LC

2nd SERIES - Supposed assembly date 1998-->

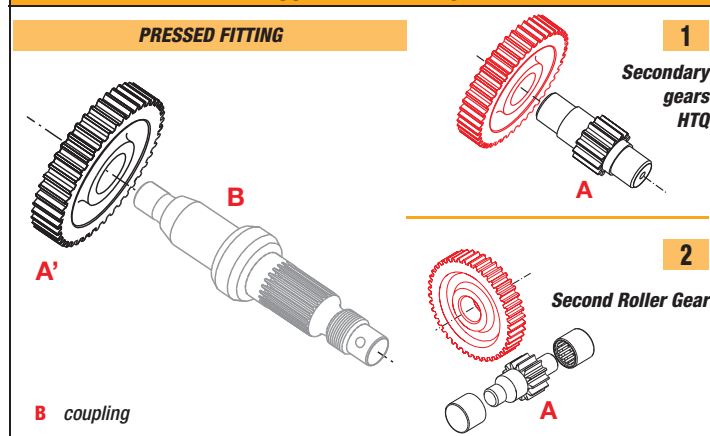

	A/A'	Art.	B Ø	Applications
SCOOTER - MAXI SCOOTER				
1	z 13/48	67 9966	17	GILERA ICE 50, RUNNER 50 2t LC, RUNNER SP 50 2t LC, STALKER 50 2t, TYPHOON X 50 2t PIAGGIO NRG EXTREME 50 2t, NRG EXTREME 50 2t LC, NRG MC2 50 2t LC, SFERA RESTYLING 50 2t
1	z 14/43	67 9925	17	GILERA RUNNER FXR 180 2t LC
1	z 14/47	67 9968	17	PIAGGIO HEXAGON LXT 180 2t LC PIAGGIO FREE 50 2t, ZIP SP 50 2t LC
1	z 15/41	6711079	17	VESPA ET2 50 2t <-1999, ET4 125 4t GILERA RUNNER FX 125 2t LC, TYPHOON X 125 2t
				ITALJET DRAGSTER 125 2t LC
1	z 15/55	6711135	17	PIAGGIO HEXAGON LX 125 2t LC, SKIPPER LX 125 2t, SKIPPER LXT 150 2t PIAGGIO LIBERTY 50 2t
SCOOTER - MAXI SCOOTER				
2	z 13/48	67 9967	17	GILERA ICE 50 2t, RUNNER 50 2t LC, RUNNER SP 50 2t LC, STALKER 50 2t, TYPHOON X 50 2t
2	z 14/47	67 9969	17	PIAGGIO NRG EXTREME 50 2t, NRG EXTREME 50 2t LC, NRG MC2 50 2t LC, SFERA RESTYLING 50 2t PIAGGIO FREE 50 2t, ZIP 50 2t, ZIP SP 50 2t LC VESPA ET2 50 2t <-1999

Table of applications Minarelli - Yamaha engines

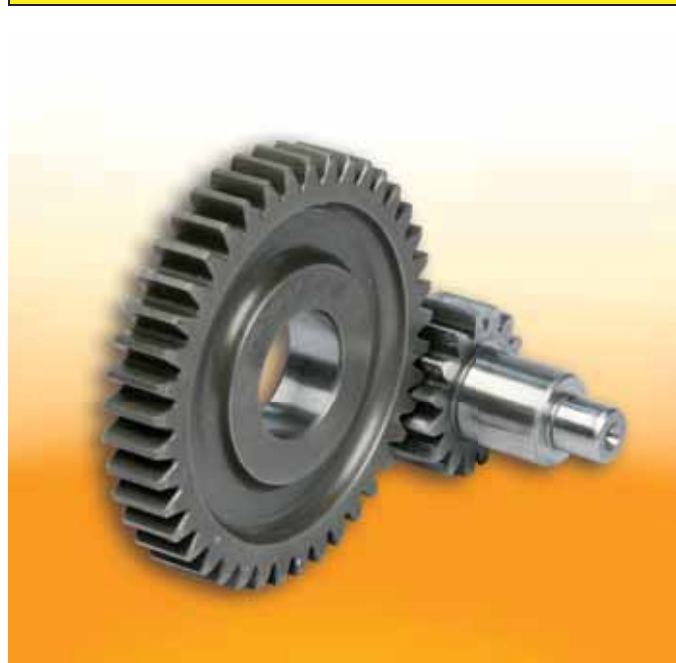







	z 15/42	z 14/43
APRILIA	6714774	6714775
AREA 51 50 2T LC	6714774	6714775
SR 50 2T 1994->	6714774	6714775
SR NETSCAPER 50 2T LC (MINARELLI)	6714774	6714775
SR RACING 50 2T LC (MINARELLI)	6714774	6714775
SR REPLICA 50 2T LC	6714774	6714775
SR STEALTH 50 2T LC (MINARELLI)	6714774	6714775
SR WWW 50 2T	6714774	6714775
BENELLI	6714774	6714775
491 SPORT 50 2T LC (MINARELLI)	6714774	6714775
MALAGUTI	6714774	6714775
F12-PHANTOM 50 2T / 50 2T LC	6714774	6714775
F12 DIGIT KAT-PHANTOM 50 2T LC / 50 2T LC euro 2	6714774	6714775
F12 R LC 50 2T LC euro 2	6714774	6714775
F15 FIREFOX 50 2T LC	6714774	6714775
MBK	6714774	6714775
NITRO 50 2T LC	6714774	6714775
OVETTO 50 2T	6714774	6714775
YAMAHA	6714774	6714775
AEROX 50 2T LC euro 0-1-2	6714774	6714775
JOG R 50 2T	6714774	6714775
JOGRR 50 2T LC euro 2	6714774	6714775
NEO'S 50 2T	6714774	6714775

New**RED
FILTER****E18 Malossi air filter**

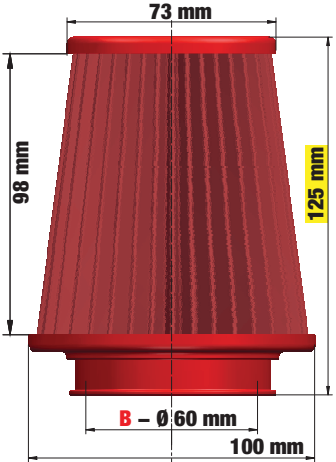
With the introduction of the sport air filters **E18**, Malossi has widened its range of products with a new range of **highly performing and resistant** air filter.

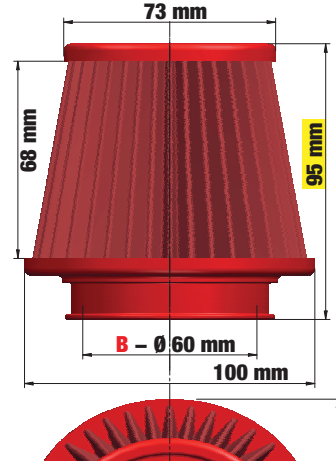
The E18 filters are champions as for versatility: as a matter of fact, although they are specifically designed for four-stroke engines, they are incredibly efficient even if applied to two-stroke engines. They are available in two different sizes (95 and 125), they may be adapted to any type of vehicle, owing to the **oval tapered structure**, able to facilitate their correct positioning and to the various types of connections available, **snap-fit or threaded**.

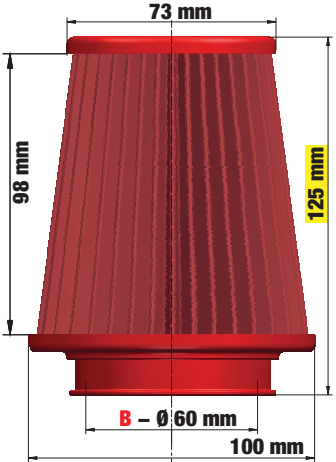
Implemented with **cotton weaves, featuring long greased multilayer fibres**, these filters have a perfect structure to keep any impurity out of the engine. Externally and internally, the fibres are protected by an aluminium mesh, which acts as a **flame break**, assuring maximum safety and, at the same time, the perfect direct air flow.

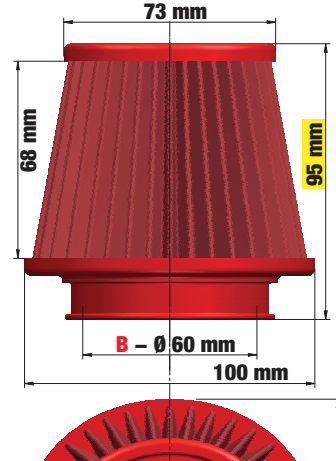
Code	Ø Inlet mm	Carburettor	Conical and elliptical centred shape
	B		Clamp fixing
 <p>0417255 € 50,00</p>	60	Dellorto: <ul style="list-style-type: none"> • Threaded PHBG 15-21 • Threaded PHBL 20-26 • With Dellorto connectors, art. B10323-B09814 supplied with the kit. 	
 <p>0417233 € 55,00</p>	42/50 ÷ 60	<ul style="list-style-type: none"> • Threaded and not Dellorto PHBH • Mikuni, Keihin carburettors and different applications With the addition of the original Dellorto connector: <ul style="list-style-type: none"> • B10323 for Dellorto PHBL 20-26 (N) • B09814 for Dellorto PHBG 15-21 (N) • B10001 for Dellorto PHBG 26-30 (N) (N) (Not supplied with the kit)	
 <p>0417254 € 48,00</p>	60	Dellorto: <ul style="list-style-type: none"> • Threaded PHBG 15-21 • Threaded PHBL 20-26 • With Dellorto connectors, art. B10323-B09814 supplied with the kit. 	
 <p>0417232 € 52,00</p>	42/50 ÷ 60	<ul style="list-style-type: none"> • Threaded and not Dellorto PHBH • Mikuni, Keihin carburettors and different applications With the addition of the original Dellorto connector: <ul style="list-style-type: none"> • B10323 for Dellorto PHBL 20-26 (N) • B09814 for Dellorto PHBG 15-21 (N) • B10001 for Dellorto PHBG 26-30 (N) (N) (Not supplied with the kit)	

New

**RED
FILTER**

481

E19 Malossi air filter for Yamaha T-Max



0417225
€ 98,89

YAMAHA T MAX 530 ie 4T LC 2012->2014 (J409E)
T MAX 530 ie 4T LC 2015-> (J409E)



**ONLY for vehicles WITH Malossi
THROTTLE BODY 1616722**

Original, **extremely performing and simple to install**, the new E19 Malossi air filter, dedicated to the Yamaha T-Max, changes the rules of the game and further widens the already rich range of products, designed for the suction of the Japanese V-twin model.

E 19 is implemented externally in open-cell polyurethane and internally, it is reinforced with a metal mesh armour. The filtering element is **15 mm thick**, it is self-extinguishing and offers a great accumulation capacity, owing to the density of **60 holes per inch**, whereas its internal mesh accurately keeps the shape and the size of the same filter.

The suction horns are incorporated by means of a **satin-finished aluminium support**, fastened on the sleeves of the same horns. This particular structure allows a **suction spacing of 180°**, assuring the engine a remarkable fresh air supply. The support is provided with the connections for the temperature sensor, for the vents of the oil vapours and for the air duct of the idling speed mode.

The installation and the maintenance of E19 are a real breath of "fresh air": the whole structure of this filter, as a matter of fact, is fastened with **only two screws and it can be disassembled even when the fairing is assembled**. The filtering element becomes bright red, and the Malossi logo stands out in yellow colour and it leans on a compact polyurethane base structure, red as well, as if it were the beating heart of your T-Max.



New**RS24**
MALOSSI
racing suspensions®

Shock absorber RS24

It is a regenerable oleo gear with bi-lamination piston and baffle plate compensation.

New

Front shock absorber RS24

4617076 € 213,00

VESPA GTS Super 125 ie 4T LC euro 3 2014->
GTS Super 300 ie 4T LC euro 3 2014-> (QUASAR M454M)
 Primavera 3V 125 ie 4T euro 3 2014-> (M811M)
 Primavera 3V 150 ie 4T euro 3 2014-> (M812M)
 Primavera 50 2T euro 2 (C533M)
 Primavera 4V 50 4T euro 2 (C532M)
 Sprint 3V 125 ie 4T euro 3 2014->
 Sprint 3V 150 ie 4T euro 3 2014->
 Sprint 50 2T euro 2
 Sprint 4V 50 4T euro 2

New

Rear shock absorber RS24

4617065 € 248,70

VESPA Primavera 3V 125 ie 4T euro 3 2014-> (M811M)
 Primavera 3V 150 ie 4T euro 3 2014-> (M812M)
 Sprint 3V 125 ie 4T euro 3 2014->
 Sprint 3V 150 ie 4T euro 3 2014->

- ø 36-mm piston with two independent lamellar packs, one in extension and one in compression; lamellar system made of harmonic steel with leaf spring configuration;
- LUBRIFLON-PTFE B70 piston runner guide (bronze-loaded modified compound);
- Sliding on GUIDA DU guide bushing (a composite material obtained by sintering a layer of spheroidal bronze on a mild steel strap properly treated, followed by impregnation and coating with a mixture of PTFE + PB);
- Polyester resin SEALTHANE grade 9345 scraper ring;
- 38NCD4 alloy steel shock absorber rod ø 14 mm, hardened and tempered with hard chrome deposit thickness 25/30 microns (superficial hardness of the untreated shaft HRC 55/60).

New

SHOCK ABSORBERS

RS24

MALOSS
racing suspensions®

483

This range of shock absorbers was born thanks to our firm's desire to offer their customers a range of products of superior class, capable of granting great riding comfort coupled with matchless driving safety.

The technical characteristics of these special shock absorbers demonstrate they are the most technically advanced on the market today:

- **RS 3** Oil-gas shock absorber with adjustable spring preload.
- **RS 24** Oil-gas shock absorber with adjustable spring preload and rebound damping.
- **RS 24/10** Oil-gas shock absorber with adjustable spring preload, compression and rebound damping, with an external compensating reservoir with hose connection that allows an increase of internal fluids.
- **RS 24/10-R** Oil-gas shock absorber with variable setting and extension/compression adjusting, compensated for a pressurized nitrogen chamber.

46 SHOCK ABSORBERS



Code	Inter-axis mm
46 7905 (P)	267
46 7906 (P)	300
46 7908 (P)	283
46 8610 (P)	New 280
4613054 (P)	307
4614616 (A)	195



Code	Inter-axis mm
46 7588 (P)	267
46 7589 (P)	300
46 7591 (P)	245
46 7900 (A)	205
46 8308 (P)	294
46 8607 (P)	360
46 8611 (P)	290
46 9031 (C)	(P) 294 + (A) 205
4611641 (P)	410
4612962 (P)	290
4613055 (P)	307
4613598 (P)	316
4614137 (A)	232
4614615 (A)	257
4614618 (P)	336
4615127 (P)	New 343
4617065 (P)	360
4617076 (A)	275



Code	Inter-axis mm
46 8298 (A)	181
4613081 (P)	315
4614223 (P)	330

Optional

2911228B
FRONT spring k = 1,6
Current Malossi spring : k = 1,4

29 9213B
REAR spring k = 1,8
Current Malossi spring : k = 1,6

Code	Inter-axis mm
4612949 (P)	285
4614245 (P)	270



Code	Inter-axis mm
4614236 (A)	180
4614237 (P)	290
4614479 (C)	(P) 290 + (A) 180

Optional

2914755B
FRONT spring k = 1,4
Current Malossi spring : k = 1,6

2914753B
REAR spring k = 1,6
Current Malossi spring : k = 1,8

DVD RS24/10 and RS24/10-R shock absorber assembly

4215100 PAL version
4215131 NTSC version

(P) rear

(A) front

(C) pair

New**Table of applications****RS24**
MALOSSI
racing suspensions®

(A) = front / (P) = rear / (C) = pair Applications	RS 3		RS 24		RS 24/10			RS 24/10-R		
	(A)	(P)	(A)	(P)	(C)	(A)	(P)	(A)	(P)	(C)
APRILIA AMICO 50 2T	---	46 7905	---	46 7588	---	---	---	---	---	---
GULLIVER 50 2T / 50 2T LC	---	46 7906	---	46 7589	---	---	---	---	---	---
RALLY 50 2T / 50 2T LC (MINARELLI)	---	46 7906	---	46 7589	---	---	4614223	---	---	---
RS 50 2T LC euro 2 2006-> (DERBI D50B1)	---	---	---	---	---	---	4612949	---	---	---
RX - SX 50 2T LC 2007-> (DERBI D50B0)	---	---	---	4612962	---	---	---	---	---	---
SCARABEO 50 2T (MINARELLI) - SCARABEO 100 2T - SONIC 50 2T / 50 2T LC	---	46 7906	---	46 7589	---	---	---	---	---	---
SR 50 2T - SR NETSCAPER 50 2T LC (MINARELLI)	---	46 7906	---	46 7589	---	---	4614223	---	---	---
SR (carb.) 50 2T LC 2004-> (PIAGGIO) - SR DITECH GP1 50 2T LC (PIAGGIO C361M)	---	4613054	---	4613055	---	---	4614223	---	---	---
SR MOTARD 50 2T euro 2	---	46 7908	---	46 8308	---	---	---	---	---	---
SR R (carb.) 50 2T LC (PIAGGIO) - SR R FACTORY 50 2T LC (PIAGGIO C361M)	---	4613054	---	4613055	---	---	4614223	---	---	---
SR RACING / SR STEALTH 50 2T LC (MINARELLI) - SR REPLICA 50 2T LC <-1999 - SR WWW 50 2T	---	46 7906	---	46 7589	---	---	4614223	---	---	---
ATALA CAROSELLO 50 2T	---	---	---	46 7591	---	---	---	---	---	---
HACKER 50 2T / 50 2T LC	---	---	---	46 7588	---	---	---	---	---	---
BENELLI 491 GT / 491 SPORT 50 2T LC (MINARELLI) - K2 50 2T / 50 2T LC - NAKED 50 2T	---	46 8610	---	46 8611	---	---	---	---	---	---
PEPE 50 2T	---	---	---	46 7591	---	---	---	---	---	---
QuattronoveX 50 2T euro 2	---	46 8610	---	46 8611	---	---	---	---	---	---
BETA ARK 50 2T / 50 2T LC - EIKON 50 2T LC	---	46 7906	---	46 7589	---	---	---	---	---	---
CHRONO 50 2T - TEMPO 50 2T	---	---	---	46 7591	---	---	---	---	---	---
BSV AX 50 - GZ 50	---	---	---	46 7591	---	---	---	---	---	---
DIO GP 50	---	46 7905	---	46 7588	---	---	---	---	---	---
DIO SP 50 - DIO SR 50 - DIO ZX 50 <-1993	---	46 7905	---	46 7588	---	---	---	---	---	---
CAGIVA CITY 50 2T	---	46 7906	---	46 7589	---	---	---	---	---	---
CPI ARAGON GP 50 2T - HUSSAR 50 2T - OLIVER 50 2T - POPCORN 50 2T	---	46 8610	---	46 8611	---	---	---	---	---	---
DERBI GPR NUDE 50 2T LC <-2005 (EBS050) / 2006-> (D50B0) -	---	---	---	---	---	---	4612949	---	---	---
GPR RACING 50 2T LC 2004->2005 (EBS050) / 2006-> (D50B0)	---	---	---	---	---	---	4612949	---	---	---
SENDA 50 2T LC (EBS050 - EBS050) - Senda EVO SM 50 2T LC (D50B0) -	---	---	---	4612962	---	---	---	---	---	---
Senda X-RACE R / X-RACE SM 50 2T LC (D50B0) - Senda X-TREME R / X-TREME SM 50 2T LC (D50B0)	---	---	---	4612962	---	---	---	---	---	---
EXPLORER CRACKER 50 2T 2003-> (GE 1E 400 MB)	---	46 8610	---	46 8611	---	---	---	---	---	---
FANTIC BIG WHEEL 50 2T	---	---	---	46 7591	---	---	---	---	---	---
GARELLI FLEXI' 50 4T euro 2 (1P139 QMB)	---	46 7905	---	46 7588	---	---	---	---	---	---
GSP 50 2T LC euro 2 (1PE40MB) - TIESSE 50R 50 2T euro 2 (1E40QMB)	---	46 8610	---	46 8611	---	---	---	---	---	---
PONY 50 2T - SR 50 2T	---	---	---	46 7591	---	---	---	---	---	---
GILERA DNA 50 2T LC	---	---	---	4611641	---	---	---	---	---	---
RCR - SMT 50 2T LC (DERBI D50B0)	---	---	---	4612962	---	---	---	---	---	---
EASY MOVING 50 2T - RUNNER 50 2T LC	---	46 7908	---	46 8308	---	---	---	---	4614237	---
RUNNER FX 125 2T LC - RUNNER FXR - SP 180 2T LC	---	---	---	46 8308	---	---	---	---	4614237	---
RUNNER PureJet 50 2T LC - RUNNER SP 50 2T LC - STORM 50 2T	---	46 7908	---	46 8308	---	---	---	---	4614237	---
STALKER 50 2T - TYPHOON 50 2T - TYPHOON X 50 2T	---	46 7908	---	46 8308	---	---	---	---	---	---
TYPHOON 125 2T - TYPHOON X 125 2T	---	---	---	46 8308	---	---	---	---	---	---
HONDA DIO G 50 2T - DIO SP 50 2T - DIO SR 50 2T - DIO ZX 50 2T <-1993 - SFX 50 2T	---	46 7905	---	46 7588	---	---	---	---	---	---
LEAD 50 2T	---	46 7905	---	---	---	---	---	---	---	---
SGX SKY 50 2T	---	46 8610	---	46 8611	---	---	---	---	---	---
SHADOW 50 2T	---	46 7906	---	46 7589	---	---	---	---	---	---
SXR 50 2T - VISION 50 2T - VISION MET IN 50 2T	---	46 7905	---	46 7588	---	---	---	---	---	---
HSC SC 01 50 - SC 01 L 50	---	46 7905	---	46 7588	---	---	---	---	---	---
HUPPER MONTECARLO 30 50 2T (1E40QMB)	---	46 8610	---	---	---	---	---	---	---	---
MONTECARLO 30 50 2T (1E40QMB)	---	---	---	46 8611	---	---	---	---	---	---
MONTECARLO 30 50 4T (139QMB)	---	46 7906	---	46 7589	---	---	---	---	---	---
ITALJET BAZOOKA 50 2T - PISTA 2 50 2T - REPORTER 50 - YANKEE 50 2T	---	---	---	46 7591	---	---	---	---	---	---
FORMULA 50 2T / 50 2T LC (F.MORINI) - TORPEDO 50 2T - VELOCIFERO 50 2T	---	46 7905	---	46 7588	---	---	---	---	---	---
KEEWAY F-ACT 50 2T - HURRICANE 50 2T euro 2 (KW1E40QMB) - MATRIX 50 2T (KW1E40QMB-4)	---	46 7905	---	46 7588	---	---	---	---	---	---
GOCCIA 50 2T (KW1E40QMB-4)	---	46 7906	---	46 7589	---	---	---	---	---	---
PIXEL 50 2T euro 2 (KW1E40QMB)	---	---	---	46 7591	---	---	---	---	---	---
RY8 50 2T (KW1E40QMB-4)	---	46 8610	---	46 8611	---	---	---	---	---	---
KYMCO DJ X 50 2T	---	46 7905	---	46 7588	---	---	---	---	---	---
DJ Y 50 2T	---	46 7905	---	---	---	---	---	---	---	---
TOP BOY - COBRA 50 2T	---	46 7906	---	46 7589	---	---	---	---	---	---
LEM FLASH 50 - GHIBLI 50 - TORNADO 50	---	---	---	46 7591	---	---	---	---	---	---
LML STAR 125 - 150 2T	---	---	4614615	---	---	---	---	---	---	---
STAR Deluxe 125 - 150 4T (E25)	---	---	4614615	4615127	---	---	---	---	---	---
MALAGUTI CENTRO 50 2T - F10 50 2T - F10 WAP 50 2T euro 2 (QJ*CMA03C*)	---	---	---	46 7591	---	---	---	---	---	---
F12-PHANTOM 50 2T / 50 2T LC - F12 DIGIT KAT-PHANTOM 50 2T LC / 50 2T LC euro 2 -	---	46 7905	---	46 7588	---	---	---	---	---	---
F12 R LC 50 2T LC euro 2 -	---	46 7905	---	46 7588	---	---	---	---	---	---
YESTERDAY 50 2T	---	---	---	46 7591	---	---	---	---	---	---
MBK ACTIVE 50 - BOOSTER / BOOSTER NG / BOOSTER ROCKET /BOOSTER SPIRIT 50 2T euro 0-1	---	---	---	46 7591	---	---	---	---	---	---
BOOSTER / BOOSTER NAKED / BOOSTER NG / BOOSTER ROCKET 50 2T euro 2 (A137E)	---	46 7905	---	46 7588	---	---	---	---	---	---
BOOSTER 100 2T	---	46 8610	---	46 8611	---	---	---	---	---	---
EVOLIS 50 2T - FIZZ 50 2T - FORTE 50 2T - HOT CHAMP 50 2T - SORRISO 50 2T - TARGET 50 2T	---	---	---	46 7591	---	---	---	---	---	---
NITRO 50 2T LC	---	46 8610	---	46 8611	---	---	4613081	---	---	---
OVETTO 50 2T	---	46 8610	---	46 8611	---	---	---	---	---	---

Products to be used exclusively for racing in places specially designed for such activity according to the regulations of the competent sporting authorities. We accept no liability resulting from improper use.

ALSO for MHR

New

Table of applications

RS24

MALOSSI

racing suspensions®

485

46 SHOCK ABSORBERS

Applications	RS 3		RS 24		RS 24/10			RS 24/10-R		
	(A)	(P)	(A)	(P)	(C)	(A)	(P)	(A)	(P)	(C)
STUNT 50 2T euro 2	---	46 7905	---	46 7588	---	---	---	---	---	---
MOTRON SYNCRO 50 - THUNDER'S 50	---	46 7906	---	46 7589	---	---	---	---	---	---
OVER B3 50 4T LC (LJ1P38MB)	---	46 7905	---	46 7588	---	---	---	---	---	---
PEUGEOT BUXY 50 2T - BUXY RS 50 2T	---	46 8610	---	46 8611	---	---	---	---	---	---
LOOXOR TSDI 50 2T - SV GEO 50 2T	---	46 7906	---	46 7589	---	---	---	---	---	---
METAL-X 50 2T - X-FIGHT 50 2T LC	---	46 7905	---	46 7588	---	---	---	---	---	---
SC L METROPOLIS 50 2T	---	46 7905	---	---	---	---	---	---	---	---
SPEEDAKE 50 2T - SQUAB 50 2T - TREKKER 50 2T - VIVACITY COMPACT 50 2T (FB2FP)	---	46 8610	---	46 8611	---	---	---	---	---	---
SPEEDFIGHT 3 50 2T (B1E 40 QMB)	---	---	---	46 8611	---	---	---	---	---	---
ZENITH 50 2T	---	---	---	46 7589	---	---	---	---	---	---
PGO BIG MAX 50	---	46 7905	---	46 7588	---	---	---	---	---	---
PIAGGIO FREE 50 2T - LIBERTY 50 2T	---	46 7908	---	46 8308	---	---	---	---	4614237	---
HEXAGON 125 - 150 2T LC - HEXAGON LX 125 2T LC - HEXAGON LXT 180 2T LC	---	---	---	46 8607	---	---	---	---	---	---
LIBERTY 125 4T euro 0-1 <-1999 - NRG Power DD 50 2T LC - NRG Power Purejet 50 2T LC	---	46 7908	---	46 8308	---	---	---	---	---	---
NRG 50 2T LC - NRG EXTREME 50 2T / 50 2T LC - NRG MC2 50 2T LC -	---	46 7908	---	46 8308	---	---	---	---	---	---
NRG MC3 DD 50 2T LC - NRG MC3 DT 50 2T - NRG Power DT 50 2T (C453M) - NTT 50 2T LC	---	46 7908	---	46 8308	---	---	---	---	---	---
QUARTZ 50 2T LC	---	46 7908	46 7900	46 8308	46 9031	46 8298	---	4614236	4614237	4614479
SFERA 50 2T - SFERA RESTYLING 50 2T	---	46 7908	46 7900	46 8308	46 9031	---	---	---	4614237	---
SFERA 75 2T	---	46 7908	46 7900	46 8308	46 9031	---	---	---	---	---
SKIPPER 125 - 150 2T	---	---	46 7900	46 8308	46 9031	---	---	---	---	---
SKIPPER LX 125 2T - SKIPPER LXT 150 2T	---	---	---	46 8308	---	---	---	---	---	---
TYPHOON 50 2T 2007->2010 - ZIP 50 4T	---	46 7908	---	46 8308	---	---	---	---	---	---
ZIP 125 4T (LEADER)	---	---	46 7900	---	---	---	---	---	---	---
ZIP 50 2T <-1999 - ZIP Fast Rider 50 2T	---	46 7908	---	46 8308	---	---	---	---	4614237	---
ZIP 50 2T 2000->	---	46 7908	---	46 8308	---	---	---	---	4614237	---
ZIP SP 50 2T LC	---	46 7908	46 7900	46 8308	46 9031	46 8298	---	4614236	4614237	4614479
RIZZATO VAMOS 50	---	46 7905	---	46 7588	---	---	---	---	---	---
SUZUKI ADDRESS AH 50 2T - AP 50 2T - SEPIA 50 2T - SEPIA ZZ 50 2T	---	46 7905	---	46 7588	---	---	---	---	---	---
STREET MAGIC 50 2T	---	---	---	---	---	---	4614223	---	---	---
VESPA 946 3V ABS 125 ie 4T (M801M)	---	---	4614137	---	---	---	---	---	---	---
ET2 50 2T	---	46 7908	46 7900	46 8308	46 9031	---	---	---	4614237	---
ET3 Primavera 125 2T	4614616	---	---	4614618	---	---	---	---	---	---
ET4 50 4T	---	46 7908	---	46 8308	---	---	---	---	---	---
ET4 125 4T - LX 4V 50 4T euro 2	---	46 7908	46 7900	46 8308	46 9031	---	---	---	---	---
ET4 125 - 150 4T (LEADER)	---	---	46 7900	---	---	---	---	---	---	---
Granturismo L - GT 125 4T LC (LEADER) - Granturismo L - GT 200 4T LC (M312M) -	---	---	4614137	---	---	---	---	---	---	---
GTS 125 4T LC euro 3 (M315M) - GTS 250 ie 4T LC - GTS Super 125 ie 4T LC euro 3 <-2013 (M455M)	---	---	4614137	---	---	---	---	---	---	---
GTS Super 125 ie 4T LC euro 3 2014-> - GTS Super 300 ie 4T LC euro 3 2014-> (QUASAR M454M)	---	---	4617076	---	---	---	---	---	---	---
GTS Super 300 ie 4T LC euro 3 <-2013 (QUASAR M454M) -	---	---	4614137	---	---	---	---	---	---	---
GTV 125 4T LC (LEADER) - GTV 250 ie 4T LC - GTV 300 ie 4T LC euro 3 (QUASAR)	---	---	4614137	---	---	---	---	---	---	---
LX 125 - 150 4T (LEADER) - LX 125 - 150 ie 4T euro 3 (LEADER) -	---	---	46 7900	---	---	---	---	---	---	---
LX 3V 125 - 150 ie 4T euro 3 2012-> - LXV 125 ie 4T euro 3 (LEADER)	---	---	46 7900	---	---	---	---	---	---	---
Primavera 3V 125 - 150 ie 4T euro 3 2014-> - Sprint 3V 125 - 150 ie 4T euro 3 2014->	---	---	4617076	4617065	---	---	---	---	---	---
Primavera 50 2T euro 2 (C533M) - Primavera 4V 50 4T euro 2 (C532M)	---	---	4617076	---	---	---	---	---	---	---
PX 80 2T - PX 125 - 150 2T euro 0-1 - PX E 200 2T	---	---	4614615	4614618	---	---	---	---	---	---
PX 125 - 150 2T euro 2 (VLX2M) - PX 125 - 150 2T euro 3	---	---	4614615	4615127	---	---	---	---	---	---
S 50 2T euro 2 (C381M)	---	46 7908	46 7900	46 8308	46 9031	46 8298	---	---	4614237	---
S 125 - 150 4T euro 3 (LEADER) - S 3V 125 ie 4T euro 3 2012->	---	---	46 7900	---	---	---	---	---	---	---
S 4V 50 4T euro 2 (C386M)	---	46 7908	46 7900	46 8308	46 9031	---	---	---	---	---
SPECIAL 50	4614616	---	---	4614618	---	---	---	---	---	---
Sprint 50 2T euro 2 - Sprint 4V 50 4T euro 2	---	---	4617076	---	---	---	---	---	---	---
WT MOTORS BILBAO 50 4T (PEDA 139QMB)	---	46 7906	---	46 7589	---	---	---	---	---	---
YAMAHA AEROX 50 2T LC euro 0-1-2	---	46 8610	---	46 8611	---	---	4613081	---	---	---
AXIS 50 2T - BELUGA 50 - BREEZE 50 2T - BW'S / BW'S NG 50 2T euro 0-1	---	---	---	46 7591	---	---	---	---	---	---
BW'S / BW'S NG 50 2T euro 2 (A137E) - BW'S Original/Naked 50 2T euro 2 2010-> (A137E)	---	46 7905	---	46 7588	---	---	---	---	---	---
CRZ 50 2T - CT 50 2T - JOG 50 2T - JOG ER 50 2T - JOG Z 50 2T	---	---	---	46 7591	---	---	---	---	---	---
JOG R 50 2T - NEO'S 50 2T	---	46 8610	---	46 8611	---	---	---	---	---	---
MT- 125 ie 4T LC (E3J4E) - YZF-R 125 ie 4T LC euro 3	---	---	---	---	---	---	4614245	---	---	---
NEO'S 4 50 ie 4T LC euro 2 (A316E)	---	46 7905	---	---	---	---	---	---	---	---
SPY 50 2T - ZEST 50 2T - ZUMA 50 2T	---	---	---	46 7591	---	---	---	---	---	---
T MAX (carb.) 500 4T LC 2001->2003 - T MAX 500 ie 4T LC 2004->2011 - T MAX 530 ie 4T LC 2012->	---	---	---	4613598	---	---	---	---	---	---

ALSO for MHR

46 7588	€	255,97	46 8308	€	248,50	4613054	€	159,64	New	4614245	€	417,18
46 7589	€	221,96	46 8607	€	141,36	4613055	€	217,60		4614479	€	814,98
46 7591	€	230,79	46 8610	€	141,25	4613081	€	524,44		4614615	€	178,50
46 7900	€	222,63	46 8611	€	219,76	4613598	€	830,00		4614618	€	230,52
46 7905	€	140,92	46 9031	€	456,47	4614137	€	178,50		4615127	€	248,70
46 7906	€	140,92	4611641	€	263,94	4614223	€	430,00		4617065	€	248,70
46 7908	€	140,92	4612949	€	508,80	4614236	€	428,49		4617076	€	213,00
46 8298	€	357,00	4612962	€	258,64	4614237	€	428,82				



Malossi is pleased to announce two new gear-box covers for scooters and Piaggio 50 cc engines, designed for racing and for a sport upgrade of standard production scooters.

Malossi, after revisiting the gear box assembly, has reduced friction drastically by replacing the original cover with two new gravity cast covers, assembled with special bearings.

These new covers, machined with high precision machines, have increased strength and reduced weight and able to withstand very high workloads, typical in racing.

Perfectly interchangeable with the original covers and complete with all necessary bearings and seal, the Roller Crankcase helps reduce friction by 4% for the MHR version P/N 2514521 and 6% for the MHR TEAM version P/N 2514603. These covers require using Malossi Secondary Roller Gears:

- **P/N 2514521 : MHR** Version to be used with Malossi Secondary Gear or original.
- **P/N 2514603 : MHR TEAM** Version to be used with Malossi Second Roller Gear.

2514521 MHR € 95,00

2514603 MHR TEAM € 95,00

for Piaggio engines



Technical Characteristics and Components

- One (1) reinforced gear-box cover, gravity-fed permanent mould casted with aluminium-silicon alloy, heat treated.
- Increased secondary shaft bores for two bearings - Two (2) special needle roller bearings - One (1) ball bearing with increased load capacity - One (1) oil seal.

Roller Crankcase for Minarelli-Yamaha engines!

New look for our MHR Roller Crankcase, made for Minarelli-Yamaha!

This restyling results in the following innovations:

- Military Green Anodized protective coating
- Milled Malossi MHR Logo
- Machined MHR Lion
- Installed bearing and oil seal for primary shaft

Technical description

Gear-box cover for scooters and Minarelli Yamaha 50 cc engines, designed for racing and for a sport upgrade of standard production scooters. Malossi, after revisiting the gear box assembly, has reduced friction drastically by replacing the original cover with the gravity cast cover, assembled with special bearings. This cover, machined with high precision machines, has increased strength and reduced weight and able to withstand very high workloads, typical in racing. Perfectly interchangeable with the original cover and complete with all necessary bearings and seal, the Roller Crankcase helps reduce friction by 4%.

Technical Characteristics and Components

- Reinforced gear-box cover, gravity-fed permanent mould casted with aluminium-silicon alloy, heat treated.
- Increased secondary shaft bores for two bearings - Two (2) special needle roller bearings - One (1) ball bearing with increased load capacity - One (1) oil seal.

Note: version to be used with Malossi Secondary Gear or original.



2515482 € 95,00



Pinwheel Shaft

MALOSSİ

New rear wheel axle, completing the set of primary and secondary gears!

This rear wheel axle is a result of Malossi's twenty years of experience in gear designing and production for road and racing scooters.

The rear wheel axle was designed and manufactured to be assembled into the original gear box without any modifications.

The Malossi engineers have worked to reduce the rotating masses, hollow the wheel axle and increase rigidity and strength of the axle.

Ideal match: MHR gear box cover, exaggerated performance!

Technical Specifications

- Material: special tri-alloy steel made to our specifications, hardened and tempered.
- Manufactured with high-precision CNC machines.
- Individually inspected to ensure the correct functional clearance.
- Entirely ground finished.

Pinwheel Shaft (Coupl. Ø 27)

6714530 € 66,30

for Piaggio engines

Pinwheel Shaft (Coupl. Ø 22,1)

6714748 € 60,18

for Minarelli - Yamaha engines



Table of applications



	Cover crankcase MHR	Cover crankcase MHR TEAM	Pinwheel Shaft	Cover crankcase MHR	Cover crankcase MHR TEAM	Pinwheel Shaft
APRILIA						
AREA 51 50 2T LC	2515482	---	6714748	2515482	---	6714748
MOJITO CUSTOM 50 2T	2514521	2514603	6714530	2515482	---	6714748
RALLY 50 2T / 50 2T LC (MINARELLI)	2515482	---	6714748	2515482	---	6714748
SCARABEO STREET 50 2T (PIAGGIO)	2514521	2514603	6714530			
SCARABEO 50 4T (PIAGGIO C373M)	2514521	2514603	6714530			
SCARABEO 4V 50 4T euro 2	2514521	2514603	6714530			
SPORTCITY ONE STREET 50 2T euro 2	2514521	2514603	6714530			
SPORTCITY ONE 50 4T (PIAGGIO C377M)	2514521	2514603	6714530			
SR 50 2T	2515482	---	6714748			
SR (carb.) 50 2T LC 2004 (PIAGGIO)	2514521	2514603	6714530			
SR DITECH GP1 50 2T LC (PIAGGIO C361M)	2514521	2514603	6714530			
SR NETSCAPER 50 2T LC (MINARELLI)	2515482	---	6714748			
SR R (carb.) 50 2T LC (PIAGGIO)	2514521	2514603	6714530			
SR R FACTORY 50 2T LC (PIAGGIO C361M)	2514521	2514603	6714530			
SR RACING 50 2T LC (MINARELLI)	2515482	---	6714748			
SR REPLICA 50 2T LC	2515482	---	6714748			
SR STEALTH 50 2T LC (MINARELLI)	2515482	---	6714748			
SR WWW 50 2T	2515482	---	6714748			
BENELLI						
491 GT 50 2T (MINARELLI)	2515482	---	6714748			
491 SPORT 50 2T LC (MINARELLI)	2515482	---	6714748			
K2 50 2T / 50 2T LC	2515482	---	6714748			
NAKED 50 2T	2515482	---	6714748			
BETA						
ARK 50 2T / 50 2T LC	2515482	---	6714748			
EIKON 50 2T LC	2515482	---	6714748			
QUADRA 50 2T	2515482	---	6714748			
DERBI						
ATLANTIS - BULLET .50 2T 2003->	2514521	2514603	6714530			
GP1 50 2T LC	2514521	2514603	6714530			
GP1 OPEN 50 2T LC	2514521	2514603	6714530			
GP1 REVOLUTION 50 2T LC	2514521	2514603	6714530			
GILERA						
DNA 50 2T LC	2514521	2514603	6714530			
ICE 50 2T	2514521	2514603	6714530			
RUNNER 50 2T LC	2514521	2514603	6714530			
RUNNER PureJet 50 2T LC	2514521	2514603	6714530			
RUNNER SP 50 2T LC <-2005	2514521	2514603	6714530			
RUNNER SP (carb.) 50 2T LC 2006-> (C451M)	2514521	2514603	6714530			
STALKER 50 2T	2514521	2514603	6714530			
TYPHOON X 50 2T	2514521	2514603	6714530			
ITALJET						
JET SET 50 2T	2514521	2514603	6714530			
TORPEDO NEW 50 2T	2514521	2514603	6714530			
MALAGUTI						
CENTRO 50 4T euro 2 (C432M)	2514521	2514603	6714530			
CIAK MASTER 50 4T euro 2	2514521	2514603	6714530			
F12-PHANTOM 50 2T / 50 2T LC	2515482	---	6714748			
F12 DIGIT KAT-PHANTOM 50 2T LC / 50 2T LC euro 2				2515482	---	6714748
F12 R LC 50 2T LC euro 2				2515482	---	6714748
F15 FIREFOX 50 2T LC				2515482	---	6714748
MBK						
BOOSTER 50 2T euro 0-1 / euro 2 (A137E)				2515482	---	6714748
BOOSTER NG / ROCKET / SPIRIT 50 2T euro 0-1				2515482	---	6714748
BOOSTER NG / NAKED / ROCKET 50 2T euro 2 (A137E)				2515482	---	6714748
MACH G 50 2T / 50 2T LC				2515482	---	6714748
NITRO 50 2T LC				2515482	---	6714748
OVETTO 50 2T				2515482	---	6714748
STUNT 50 2T euro 0-1-2				2515482	---	6714748
PIAGGIO						
DIESIS 50 2T	2514521	2514603	6714530			
FLY 50 2T - 4T	2514521	2514603	6714530			
FREE 50 2T 2001->	2514521	2514603	6714530			
LIBERTY 50 2T - 4T	2514521	2514603	6714530			
LIBERTY 4V 50 4T euro 2	2514521	2514603	6714530			
NRG EXTREME 50 2T / 50 2T LC	2514521	2514603	6714530			
NRG MC2 50 2T LC 1998->	2514521	2514603	6714530			
NRG MC3 DD 50 2T LC	2514521	2514603	6714530			
NRG MC3 DT 50 2T	2514521	2514603	6714530			
NRG MC3 Purejet 50 2T LC	2514521	2514603	6714530			
NRG Power DD 50 2T LC	2514521	2514603	6714530			
NRG Power DT 50 2T (C453M)	2514521	2514603	6714530			
NRG Power Purejet 50 2T LC	2514521	2514603	6714530			
TYPHOON 50 2T 2007->2010	2514521	2514603	6714530			
TYPHOON 50 2T euro 2 2011	2514521	2514603	6714530			
ZIP 50 2T 2000	2514521	2514603	6714530			
ZIP SP 50 2T LC 2001->	2514521	2514603	6714530			
ZIP 50 4T	2514521	2514603	6714530			
VESPA						
ET2 50 2T 2000	2514521	2514603	6714530			
ET4 50 4T	2514521	2514603	6714530			
LX 50 2T - 4T	2514521	2514603	6714530			
S 50 2T euro 2 (C381M)	2514521	2514603	6714530			
S 4V 50 4T euro 2 (C386M)	2514521	2514603	6714530			
YAMAHA						
AEROX 50 2T LC euro 0-1-2	2515482	---	6714748			
BW'S - BW'S NG .50 2T euro 0-1	2515482	---	6714748			
BW'S - BW'S NG .50 2T euro 2 (A137E)	2515482	---	6714748			
BW'S Original/Naked 50 2T euro 2 2010 (A137E)	2515482	---	6714748			
JOG R 50 2T	2515482	---	6714748			
JOGRR 50 2T LC euro 2	2515482	---	6714748			
NEO'S 50 2T	2515482	---	6714748			
SLIDER 50 2T	2515482	---	6714748			

New

Malossi is pleased to offer their customers its new final transmission gear assembly...

THIRD SUPPORT

6714733 € 125,16

**MBK NITRO 50 2T LC
YAMAHA AEROX 50 2T LC euro 0-1-2**



Malossi, always attentive to rider's observations and requests, has focused on Minarelli-Yamaha, considering the CVT system has shown some deficiencies.

At high RPMs, the driven pulley generates strong vibrations and oscillations to the primary gear shaft. To remedy this problem, an additional bearing, inserted into the original crankcase cover is used creating a third support for a redesigned longer gear shaft. This modification prevents the gear shaft from flexing thus allowing the CVT system to operate correctly.

Two simple modifications are required to install this support bearing in the original crankcase cover (See assembly instructions).

Technical Characteristics

- H.t.q. gears z 14/42 designed with straight teeth reducing to a minimum, losses due to friction, and stresses in the supports.
- Optimized gear ratios.
- Extended primary gear shaft.
- Polished steel alloy bearing support.
- Sealed bearing.

Note: to be assembled only with original crankcase cover.

Code	Spare parts
0614865E	2 O-RING Ø 5,50x1,50 mm
1914732B	NUT M 10x1x05,7 mm for CLUTCH BELL
2014875B	RADIAL ROL. BEARING/BOLTS KIT for PRIMARY GEARS (THIRD SUPPORT)
6614373B	RADIAL ROLLER BEARING Ø 08x24x08 mm
6714370	PRIMARY GEARS (THIRD SUPPORT) z 14/42



Power Transmission MHR

Malossi Super T Max quickens its steps.

Mhr Power Transmission, art. 6714757, is a Malossi project:

HTQ Z 26/40 pinion and ring gear pair with lengthened gear ratio,

Malossi Morse lightened, narrower, frictionless racing chain.

This system completely replaces the original primary gears (25-tooth pinion and 41-tooth ring gear) with a 26-tooth drive pinion and a 40-tooth driven ring gear, thus providing a 7% longer ratio.

Besides providing this longer ratio, these gears are narrower, as to fit the new Malossi Morse racing chain, which is frictionless and without friction springs, thus lighter, more sliding and with higher resistance and long life compared to the original one, since "you can't break what is missing".

Malossi is glad and proud to offer its customers a further masterpiece of modern technology.



6714757 € 265,00

Technical details

HTQ Z 26/40 pinion and ring gear pair

- 1) Toothed ring gear pair with narrower walls, consisting of one 26-tooth drive pinion and one 40-tooth driven ring gear, made in Cr Ni Mo 5 alloy steel, tempered and case-hardened, manufactured basing on Malossi design with high precision machine tools.
- 2) Tooth profile designed for maximum resistance and minimum noise.
- 3) Tooth contact surfaces provided with maximum finish to ensure very long life and operating reliability.
- 4) High-standard inspections on each component, from raw materials to the finished product, ready for sale.

Malossi Morse Racing chain

Narrower chain, designed to eliminate the lateral friction of the original chain.



NB: we recommend not to modify Malossi Morse racing chain, art. 6114474B, in order to fit the original or other manufacturers' pinion and ring gear pair. Malossi does not assume any responsibility, thus won't recognize any warranty in case of damage.

Power Transmission SPORT

z 26/40 for ORIGINAL CHAIN

6714418 € 148,00

With Malossi it's now possible to lengthen the gear keeping the original chain! Very new gear sets which lengthen the pitch of about 7%; they must not be confused with Power Transmission MHR system art. 6714757. This Sport version must be used only with the original chain since Malossi racing chain is narrower and it doesn't accept original or similar ring gears.



New



The lifeblood of your engine

For the correct operation of an engine and of all its parts, nothing is more important than the perfect lubrication. This is the reason why Malossi, producer of special ultra-high performance components, has over time, introduced a line of lubricants specially developed to enhance the technical characteristics of its products.

Searching for lubricants available on the market perfect to enhance the technical characteristics of its engines and of its automatic transmissions, Malossi had quickly recognised the need to formulate a complete line of lubricants specifically for its products, above all for two-stroke engines where the engine oil plays an active role even in the combustion phase.

So 7.1. came into being, a Malossi Group brand, a full range of lubricants developed to complement and keep pace with the technical evolution of the two and four stroke and engines.

The 7.1 lubricant formulas are unique and the trademark is a true icon in the competition world. All of the range was developed to guarantee durability and performance for racing engines or those of street bikes and scooters, under all types of conditions.

Continually evolving, 7.1. is the boost to your performance, the defence shield for your mechanics, it is simply the lifeblood of your engine.

New



491

76 LUBRICANTS

RACING FILTER OIL FULL SYNT

7617078 [12] Bottles of 0,25 L

€ 62,01

AIR FILTER TREATMENT SYNTHETIC LUBRICANT

Surface treatment of high technology, developed to increase the efficiency of the air filters. Biodegradable over 90%.

It contains additives with high polarity that confer superior adhesiveness, preventing the passage of sand, dust and water without altering the air passage. Developed to provide protection to the engine even under the most severe operating conditions. It reduces the risk of breakage and contributes to longer engine life.

Free of chlorinated solvents, does not damage the material from which the filter.

APPLICATION:

Use a regular degreaser / cleaner removable with water, for normal cleaning of the filter. Rinse with water and dry.

Soak in the synthetic lubricant for air filters treatment, remove any excess and let dry, allowing the formation of a lubricating film before reinstalling the filter and start the engine.



New

7.1
 MOTOROIL®

Engine oil for **SCOOTER 4T**

4T OIL SPORT ENGINE

Specifications : **API SG, SH, SJ - JASO MB**

[6] Bottles of 1 L

New synthetic lubricant, specific for the use in modern scooter and motorcycle 4 stroke engines with high performance. It offers an excellent thermal stability and stay-in-grade within a vast range of temperatures, with higher anti-rust and anti-wear features. Compatible with catalytic exhaust systems prolonging the life of the catalytic exhaust, higher gas mileage, and a reduction in emissions. A Multi-Grade oil that allows optimum engine performance and easier starts in every season.



7612446S € 77,04
 (SAE 5W-40)



7614053 € 64,03
 (SAE 10W-30)



7612445S € 63,73
 (SAE 10W-40)



7613475 € 64,21
 (SAE 15W-50)

4T OIL RACING FULL SYNT

Specifications : **API SG, SH, SJ - JASO MB**

[6] Bottles of 1 L

Full Synthetic Ester 4-Stroke Engine Oil for competition Scooters and Motorcycles. The product offers excellent stay-in-grade performance over a wide temperature range with outstanding anticorrosion and anti-wear characteristics.

- Superior stay-in-grade performance ensures full protection throughout the service life of the oil.
- Catalytic converter compatible, prolongs catalyst life thus maintaining environmentally acceptable emission tolerances.
- Low volatility reduces emissions, extends exhaust system life and ensures low oil consumption.
- Viscosity characteristics ensure fuel efficient operation and easy starting in both summer & winter conditions.
- Excellent anti-wear and anti-corrosion properties reduce friction thus promoting performance retention and long engine life.



7613473 € 80,01
 (SAE 5W-40)



7614123 € 65,51
 (SAE 10W-50)

New

Engine oil for **MOTO 4T**



493

76 LUBRICANTS

4T OIL SPORT ENGINE (SAE 10W-40)

7615797 [6] Bottles of 1 L € 63,32

Specifications : API SG, SH, SJ - JASO MA2

Synthetic oil based lubricant for 4-stroke ENGINES of street bikes. The grade required and recommended by all the manufacturers of street bikes. This formulation, based on synthetic oils, ensures maximum reliability in any environmental condition. Ensures an excellent level of protection against wear of lubricated components and superior engine cleanliness with extended life. Suitable for gearboxes and transmissions where the manufacturer suggests the use of SAE 10W-40 engine oil. Reduces fuel consumption and emissions, and provides maximum corrosion protection even in periods of intermittent use. Compatible with catalytic converters. This product can be used in wet clutch systems.



4T OIL RACING FULL SYNT (SAE 5W-40)

7615800 [6] Bottles of 1 L € 76,74

Specifications : API SG, SH, SJ - JASO MA, MA2

100% synthetic ester lubricant for high-performance 4-stroke ENGINES, mainly for motorcycle racing. The reduced internal friction, thanks to its low viscosity, allows the engine to unleash more power. The service life and protection of the lubricated components are ensured by the high stability of the lubricant film at all operating temperatures. The high cleaning power ensures superior engine cleaning, and maintains performance. Compatible with catalytic converters. Low volatility and reduced fuel consumption and emissions. This product can be used in wet clutch systems.

New

Engine oil for **SCOOTER 2T**

**76 8231S**

2T OIL SPORT ENGINE (SAE 20W-30)

Specifications : **API TC - JASO FC****[6] Bottles of 1 L****€ 72,05**

It is a special semi-synthetic lubricating oil of high quality tested for both liquid and air cooled racing engines, with or without mixer. It is suitable for any 2-strokes engines and it offers very high performances. 7.1 is a lubricating oil composed of ash-free additives and it is able to guarantee the maximum cleanness of the involved components, absence of deposits, substantial reduction of smokes.

**7616711****New**

2T OIL TOP RACING FULL SYNT (SAE 40)

Specifications : **API TC - JASO FC - JSO L-EGD****[6] Bottles of 1 L****€ 156,46**

Developed exclusively for racing 2-stroke engines, 7.1 TOP RACING is formulated using synthetic esters that ensure exceptional anti-wear properties, reducing internal friction and guaranteeing consistent performance over time. 7.1 TOP RACING ensures superior load-resistance and cleanliness characteristics for racing engines, requirements necessary for the full development of power even with very rich oil-gasoline (oil-petrol) blends. 7.1 TOP RACING is particularly resistant to sticking piston rings and the formation of residues on spark plugs, to help the engine to develop maximum power for the whole duration of the race. The product forms a tough film between the cylinder, piston and piston ring, prolonging the life of the engine. It can be mixed with any type of gasoline (petrol), in every season of the year, without any problem of mixing and stability of the mixture.

**76 8230S**

2T OIL RACING FULL SYNT (SAE 20W-30)

Specifications : **API TC - JASO FC****[6] Bottles of 1 L****€ 104,84**

Thanks to the experience Malossi gained in races, an innovative product for 2-stroke engines with high performance was born. 7.1 is a completely synthetic lubricating oil obtained with a high quality synthetic base and carefully selected additives to guarantee the highest performance without neglecting the protection of the environment. It has been designed for racing vehicles with or without separate mixer.

7.1 guarantees:

- High engine efficiency
- Reduction of the wear of the involved components and thereby a longer life of the vehicle.
- Minimum formation of incrustations and deposits in the combustion chamber and at the exhaust.
- It avoids piston rings to be stuck together and therefore it guarantees the perfect tightness of the compression for long.
- Substantial reductions of exhaust smokes.



New



495

76 LUBRICANTS

OIL DRUMS MALOSSI 7.1

New synthetic lubricant, specific for the use in modern scooter and motorcycle 4 stroke engines with high performance. It offers an excellent thermal stability and stay-in-grade within a vast range of temperatures, with higher anti-rust and anti-wear features. Compatible with catalytic exhaust systems prolonging the life of the catalytic exhaust, higher gas mileage, and a reduction in emissions. A Multi-Grade oil that allows optimum engine performance and easier starts in every season.



7615400 Drum 58 L	€ 661,20	4T OIL SPORT ENGINE	(SAE 5W-40)
7614072 Drum 200 L	€ 2.242,75	4T OIL SPORT ENGINE	(SAE 5W-40)
7615399 Drum 58 L	€ 501,82	4T OIL SPORT ENGINE	(SAE 10W-40)
7614071 Drum 200 L	€ 1.782,32	4T OIL SPORT ENGINE	(SAE 10W-40)
7614074 Drum 200 L	€ 1.872,49	4T OIL SPORT ENGINE	(SAE 15W-50)
7614073 Drum 200 L	€ 2.277,33	4T OIL RACING FULL SYNT	(SAE 5W-40)

7613465

SPORT BRAKE FLUID (DOT 4)

[12] Bottles of 0,25 L € 51,08

BRAKE FLUID.

Brake fluid fully synthetic for scooters and motorcycles, with additives specially designed to protect both all the components of brake system and the rubber parts. This fluid grants extraordinary braking performances both at low and high speed.



7613467

RACING BRAKE FLUID FULL SYNT (DOT4+)

[12] Bottles of 0,25 L € 67,00

BRAKE FLUID.

Brake fluid fully synthetic for scooters and motorcycles, with additives specially designed to protect both all the components of brake system and the rubber parts. This fluid grants extraordinary braking performances both at low and high speed.



New



7.1
MOTOR OIL®

7614336

VESPA GEAR OIL (SAE 80W-90)

[12] Bottles of 0,25 L

€ 51,08

VESPA GEAR OIL

Advanced formula oil expressly formulated *for all Vespa gear* cases and transmissions, from the most recent to the very first models!

It contains E.P. additives which protect transmission parts even under severe shock load conditions and give outstanding long life wear resistance.

By reducing viscous drag and friction, the product ensures smooth and slick gear changes, reducing wear and transmission power losses.

The unique thermally stable construction of these lubricants maintains higher protection in all climates.

This product has been tested on all models of Vespa wet clutches.

It grants higher performances and it prevents the overheating of the gear parts in such a better way compared to the traditional mineral oils.



Typical Properties			
Properties	U.M.	Values	Standard
SAE Viscosity Grade – Gear Oil		80W	
SAE Viscosity Grade – Motor Oil		10W-30	
Viscosity			
a 40°C	mm ² /s	62.0	ASTM D 445
a 100°C	mm ² /s	9.2	ASTM D 445
Viscosity Index		127	ASTM D 2270
Pour Point	°C	-30	ASTM D 97

7613471

RACING GEAR OIL FULL SYNT (SAE 75W-90)

[12] Bottles of 0,25 L

€ 56,07

GEAR OIL

Synthetic gear lubricant for racing scooters and bikes. It has high natural viscosity index and excellent shear strength, as well as higher load resistance. The synthetic materials used for this formulation have an oxidation stability up to 3 times higher than that of traditional mineral oils, prolonging the effective life of the lubricant, even if subjected to extreme working conditions. Beside this, the lower friction value leads to reduced pitting and wear of the gear teeth. Its excellent E.P. features and its low viscosity help in protecting the gearbox components.



7613469

SPORT GEAR OIL (SAE 80W-90)

[12] Bottles of 0,25 L

€ 51,08

GEAR OIL

Advanced specification gear and transmission oil. It contains E.P. additives which protect transmission parts even under severe shock load conditions and give outstanding long life wear resistance. By reducing viscous drag and friction, the product ensures smooth and slick gear changes, reducing wear and transmission power losses. The unique thermally stable construction of these lubricants maintains higher protection in all climates. This product can be used in wet clutch systems. It grants higher performances and it prevents the overheating of the gear parts in such a better way compared to the traditional mineral oils.



New



MRG grease

7611882S

[6] Tubes of 40 gr € 31,77

High resistance grease with a mineral base and a special formulation with molybdenum sulphide additive. MRG has been studied for scooter variators and torque drivers. It provides extended life of rollers and of all mechanical parts.

- for all the ORIGINAL and MALOSSI TORQUE DRIVER (mobile driven split pulley)
- for VARIATORS that require lubricating grease, as indicated in the Fitting Instructions

NOTE. must only be used with variators that require grease.



MHR grease

Semi-synthetic high performance grease with a lithium complex soap thickener.

7615375S [6] Tubes of 40 gr € 46,80

The new MALOSSI 7.1 MHR GREASE, recommended for use in extreme conditions or with operating temperatures up to 160° C.

Description

MALOSSI 7.1 MHR GREASE is recommended for the lubrication of scooter variators and rear pulley assemblies, operating under severe load and temperature conditions; specifically it guarantees perfect lubrication between the hub and half pulley bushing resulting in extended maintenance intervals. MALOSSI 7.1 MHR GREASE is a high performance grease which combines mineral and synthetic oils, lithium complex soap thickener and anti-corrosion, anti-rust, anti-wear, and E.P. additives.

The chemical composition of this grease produces superior anti-corrosion and thermal/mechanical stress resistant properties, even at extreme operating conditions.

Specifications and Approvals

Meets or exceeds the following industry specifications:

- ISO 6743-9 L-XCCEB 2/1
- DIN 51502 KP 2/1 P -30

Features and Benefits

- Excellent protection against rust and corrosion and resistance to water wash out.
- Elevated dropping point.
- Excellent pumpability.
- Extended lubrication intervals translating into reduced operational costs.
- Compelling anti-corrosive characteristics of lubricated parts.



Typical Properties

Properties	U. M.	Values	Standard
NLGI Grade		2	DIN 51818
Texture		Smooth, Buttery	Visual
Colour		Light brown	Visual
Penetration-worked	mm/10	280 / 310	DIN ISO 2137
Dropping Point	°C	> 250	IP 396 / 93
Steel corrosion protection (EMCOR Test /3% NaCl)	Grado	0 - 0 2 - 2	DIN 51802
Copper corrosion protection, 24 hrs @140°C	Grado	< 2	DIN 51811
Oil separation, one week @ 40°C	%	1 - 3	DIN 51817
Water resistance @ 90°C	Nivel	1 - 90	DIN 51807 - 1
Operational temperature range	°C	-0,188	DIN 51825
Oxidation Stability	bar	< 0,5	DIN 51808
Base oil type		Mineral Oil / PAO	
Base oil viscosity , mm2/s	40°C	2800	DIN 51562 - 1
	100°C	22	



SCREENS

An aggressive line of aerodynamic and protective screens perfectly interchangeable with the originals, made with a superior acrylic PMMA material, smoke colour.

Computer Aided Designed utilising precise dimensions to maximise rider visibility in a race tuck position, a serious race enhancement for your scooter.

4513099 (W425 x H450 x THK3 mm) € 61,50

APRILIA

SR MAX 125 ie 4T LC euro 3

SR MAX 300 ie 4T LC euro 3

GILERA

NEXUS 125 – 125 ie 4T LC euro 3

NEXUS 250 – 300 ie 4T LC euro 3

NEXUS 500 ie 4T LC euro 2-3



4514399 (W395 x H420 x THK3 mm) € 64,50

GILERA

GP 800 4t LC (PIAGGIO M554M)



4515571B (W410 x H400 x THK3 mm) € 65,00

BMW

C Sport 600 ie 4T LC euro 4 <-2015

C Sport 650 ie 4T LC euro 4 2016-> (652EA)

Dark smoke



4515607B (W410 x H400 x THK3 mm) € 59,45

BMW

C Sport 600 ie 4T LC euro 4 <-2015

C Sport 650 ie 4T LC euro 4 2016-> (652EA)

Clear



**4517067** (W370 x H370 x THK3 mm) € 63,00**HONDA**

FORZA ABS 125 ie 4T LC (JF60E)

**4515621B** (W432 x H445 x THK3 mm) € 64,50**HONDA**INTEGRA 700 ie 4T LC
INTEGRA 750 ie 4T LC**4514611** (W480 x H360 x THK3 mm) € 56,00**HONDA**

SH I 125 – 150 ie 4T LC <–2008

**4514608** (W475 x H355 x THK3 mm) € 56,00**HONDA**

SH I 125 (JF14E) – 150 (KF08E) ie 4T LC euro 3 2009–>

**4516053** (W478 x H367 x THK3 mm) € 72,00**HONDA**

SH I ABS 125 – 150 ie 4T LC euro 3 2013–>

**4516499** (W480 x H340 x THK3 mm) € 75,00**HONDA**

SH mode 125 ie 4T LC euro 3 (JF51E)

**4514607** (W466 x H357 x THK3 mm) € 65,00**HONDA**

SH I – SH I Scoopy 300 ie 4T LC (NF02E) <–2010

**4515124** (W498 x H350 x THK3 mm) € 66,00**HONDA**

SH I – SH I Scoopy 300 ie 4T LC 2011–>2014

**4517070** (W480 x H345 x THK3 mm) € 66,00**HONDA**

SH I 300 ie 4T LC euro 4 2015–> (NF05E)





MALOSSİ

4516055 (W380 x H230 x THK3 mm) € 73,80

PIAGGIO

BEVERLY 300 ie 4T LC euro 3 2010-> (M692M)
BEVERLY Sport Touring 350 ie 4T LC euro 3



4517366 (W450 x H340 x THK3 mm) € 66,00

PIAGGIO

LIBERTY iGet 50 ie 4T euro 3 (C541M)
LIBERTY iGet ABS 125 ie 4T euro 3 (M893M)
LIBERTY iGet ABS 150 ie 4T euro 3



4517448 (W540 x H370 THK3 mm) € 73,80

PIAGGIO

MEDLEY 125 ie 4T LC euro 4
MEDLEY 150 ie 4T LC euro 4



4515655B (W535 x H570 x THK3 mm) € 72,00

PIAGGIO

X10 125 - 350 - 500 ie 4T LC euro 3



4516330B (W520 x H460 x THK3 mm) € 61,00

KAWASAKI

J ABS 125 ie 4T LC euro 3 (WS25)
J 300 ie 4T LC euro 3 (WS60)





4515116 (W485 x H472 x THK3 mm) € 65,00

KYMCO

DINK Street 125 – 200 – 300 / 300 2012-> ie 4T LC euro 3
DOWNTOWN 125 – 200 – 300 / 300 2012-> ie 4T LC euro 3
NIKITA 200 – 300 ie 4T LC euro 3
SUPER DINK 125 – 200 – 300 / 300 2012-> ie 4T LC euro 3



4517073 (W430 x H515 x THK3 mm) € 63,00

KYMCO

DOWNTOWN i ABS 350 ie 4T LC euro 3 (SK64)



4516574 (W440 x H380 x THK3 mm) € 70,00

KYMCO

XCITING 400 ie 4T LC euro 3 (SK80)



4516052 (W445 x H530 x THK3 mm) € 70,80

KYMCO

K-XCT 300 ie 4T LC euro 3 (SK60B)



4517457 € 73,80

KYMCO

X-Town CBS 125 ie 4T euro 4
X-Town ABS 300 ie 4T euro 4

New





MALOSI

4516502 (W360 x H410 x THK3 mm) € 79,00

YAMAHA
MAJESTY S 125 ie 4T LC



4514760 (W460 x H688 x THK3 mm) € 63,00

YAMAHA
T MAX 500 ie 4T LC 2008->2011

SPORT



4514012 (W460 x H574 x THK3 mm) € 63,00

YAMAHA
T MAX 500 ie 4T LC 2008->2011

MHR



4515359 (W445 x H430 x THK3 mm) € 65,00

YAMAHA
T MAX 530 ie 4T LC 2012-> (J409E)

SPORT



4516328 (W460 x H280 x THK3 mm) € 67,00

YAMAHA
T MAX 530 ie 4T LC 2012-> (J409E)

MHR



4515361 (W465 x H505 x THK3 mm) € 63,00

YAMAHA
T MAX 500 4t LC (carb.) 2001->2003
T MAX 500 ie 4T LC 2004>2007

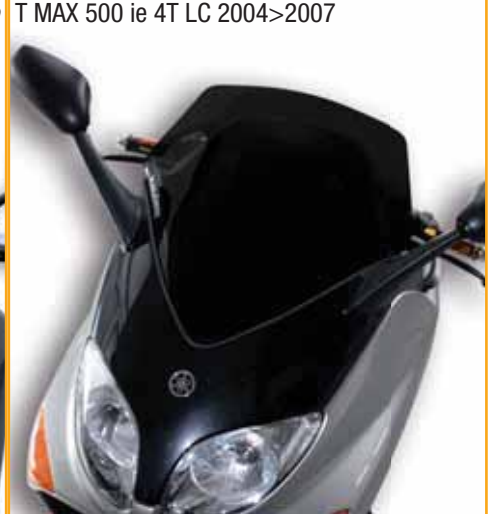

4514400 (W380 x H290 x THK3 mm) € 52,00

YAMAHA
X MAX 125 ie 4T LC euro 3 <- 2008
X MAX 250 - 250 ie euro 3 2008->2009 4T LC



4514604 (W380 x H250 x THK3 mm) € 52,00

YAMAHA
X MAX 125 ie 4T LC euro 3 2009 -> 2013
X MAX 250 ie 4T LC euro 3 2010 -> 2013



4516051B (W370 x H350 x THK3 mm) € 64,50

MBK
EVOLIS 250 ie 4T LC 2014 ->
EVOLIS 400 ie 4T LC
YAMAHA
X MAX 125 ie 4T LC euro 3 2014->
X MAX 250 ie 4T LC euro 3 2014->
X MAX 400 ie 4T LC euro 3 (H330E)





SCREENS



4515118 (W500 x H330 x THK3 mm) € 67,00

VESPA

Granturismo L – GT 125 4T LC (LEADER)
GTS 125 4T LC euro 3 (M315M)
GTS Super 125 ie 4T LC euro 3
Granturismo L – GT 200 4T LC (M312M)
GTS 250 ie 4T LC
GTS Super 300 ie 4T LC euro 3 (QUASAR M454M)



4515120 (W507 x H440 x THK3 mm) € 64,00

LML

STAR 125 – 150 2T
STAR Delux 125 – 150 4T (E25)

VESPA

PX 80 2T
PX 125 – 150 2T euro 0–1–2–3
PX 200 E 2T

Dark smoke



4515122 (W335 x H227 x THK3 mm) € 59,00

LML

STAR 125 – 150 2T
STAR Delux 125 – 150 4T (E25)

VESPA

PX 80 2T
PX 125 – 150 2T euro 0–1–2–3
PX 200 E 2T

Clear



4516054 (W530 x H420 x THK3 mm) € 73,80

VESPA

LX 50 2T – 4T
LX 125 – 150 4T (LEADER)
LX 125 – 150 ie 4T euro 3 (LEADER)
LX 3V 125 – 150 ie 4T euro 3 2012-->



4516332 (W510 x H420 x THK3 mm) € 75,00

VESPA

Primavera 50 2T euro 2 (C533M)
Primavera 4V 50 4T euro 2
Primavera 3V 125 ie 4T euro 3 2014-->
Primavera 3V 150 ie 4T euro 3 2014-->



4516342 (W540 x H400 x THK3 mm) € 75,00

VESPA

Sprint 50 2T euro 2
Sprint 4V 50 4T euro 2
Sprint 3V 125 – 150 ie 4T euro 3 2014-->





An important factor in selecting spark plugs, is heat range. This determines how quickly heat is conducted away from the spark plug's firing tip. Spark plugs operating at excessively high temperatures or at excessively low temperatures can create problems. The former does not allow the spark plug to cool sufficiently resulting in pre-ignition and the latter generates carbon deposit on the electrode. Denso operates between 400 and 900 degrees C, an ideal range that allows the spark plug to self-clean between combustion cycles.

This series offers:

- 1) Stronger sparks at lower voltages
- 2) Better firing performance and improved acceleration



Code	Price	Description
6314455.S0	€ 25,44	DENSO W34 ES-ZU
6312594	€ 14,07	DENSO U31 ET-R
6314454.I0	€ 28,82	DENSO IRIIDIUM IW F 24
6314454.L0	€ 26,50	DENSO IRIIDIUM IW F 27
6314455.I0	€ 25,44	DENSO IRIIDIUM IW 24
6314455.L0	€ 27,85	DENSO IRIIDIUM IW 27
6314455.P0	€ 25,44	DENSO IRIIDIUM IW 31
6314455.S0	€ 25,44	DENSO IRIIDIUM IW 34

ATTENTION:

A complete description of the spark plug desired is needed when ordering.

(*) Es.

6314454.L0 IW F 27

63 7409.S0 W34 ES-ZU

Es.

W.. FS-ZU

U.. ET-R

IW ..

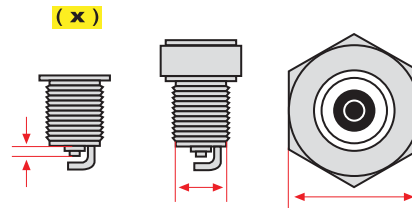

Letter	Electrode Type (x)	Thread Ø mm	Hex Size mm
W	platinum	14	20,6
U	platinum	10	16
I	iridium	8	13

Es.

W34 ES-ZU

IW F 27



Temperature designation

Hot	← → Cold			
(*) 24	27	31	34	
.I0		.L0		
		.P0		
			.S0	

Es.

W.. FS-ZU

W.. FP-T

U.. ET-R

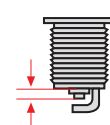

Letter	Electrode Shape (Type)
S	Standard
P	Projected electrode
T	Double ground electrodes

Es.

W.. ES-ZU

W.. FS-ZU

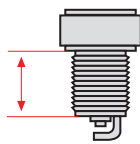

Letter	Thread length mm
E	20,0
F	12,7

Es.

U.. ET-R



Letter	Construcción interior
(none)	Without resistor
R	With resistor

MALOSSI OFF-ROAD HELMET

Technical features

- Polycarbonate outer shell
- EPS dual-density inner shell
- Upper ventilation and chin rest
- Internal air circulation
- Micrometric buckle for the chinstrap closing
- Fully removable and washable ergonomic liner in hypoallergenic fabric
- Anti-noise netting



4115976.B € 148,63
BLACK BRIGHT

**MALOSSI**

MALOSSI FULL-FACE HELMET

Technical features

- Fiberglass outer shell stratified with Multi Axial system
- EPS dual-density inner shell
- Upper and rear ventilation
- Internal air circulation
- Double D-ring chinstrap
- Anti-scratch visor with quick release system
- Fully removable and washable ergonomic liner in hypoallergenic fabric
- Anti-noise netting
- Elastic nose shield
- Homologated according to European Law CE 22-05



4114696.W € 143,50
WHITE BRIGHT



4114696 € 143,50
BLACK MATT

VISORS FOR MALOSSI FULL-FACE HELMET

4114735.NO CLEAR VISORS
€ 20,20



4114735.LO LASER VISORS
€ 36,00



4114735.FO SMOKE VISORS
€ 30,00



MALOSSI JET HELMET

Technical features

- Polycarbonate outer shell
- EPS dual-density inner shell
- Micrometric buckle for the chinstrap closing
- Anti-scratch visor with quick release system
- Fully removable and washable ergonomic liner in hypoallergenic fabric
- Homologated according to European Law CE 22 05



4115640.W € 81,00
WHITE BRIGHT



4115640.B € 81,00
BLACK BRIGHT

VISORS FOR MALOSSI JET HELMET

4116682BF SMOKE AVIATORE VISOR
€ 17,00



4116683BN CLEAR LONG VISOR
€ 20,00



Following sizes available:

4115640.B2 tg. XS

ATTENTION: When ordering, please remember to attach the codenumber that represents the desired size to the part number. See example above in RED.

OFF-ROAD		FULL-FACE		JET		Size	Head circumference (cm)
BLACK BRIGHT	BLACK MATT	WHITE BRIGHT	BLACK BRIGHT	WHITE BRIGHT			
4115976.B2	4114696.20	4114696.W2	4115640.B2	4115640.W2	XS	53/54	
4115976.B3	4114696.30	4114696.W3	4115640.B3	4115640.W3	S	55/56	
4115976.B4	4114696.40	4114696.W4	4115640.B4	4115640.W4	M	57/58	
4115976.B5	4114696.50	4114696.W5	4115640.B5	4115640.W5	L	59/60	
4115976.B6	4114696.60	4114696.W6	4115640.B6	4115640.W6	XL	61/62	

MALOSSİ GRIPS

suitable for all vehicles

The importance of grip is well known since the mists of time. Man has always strived to create safer and more effective grips on tools and weapons, without neglecting to personalise them, sometimes embellished with precious materials. At last today, your motorcycle too can have something special: Malossi took care of it!

A firm grip is never missing, palm and fingers grasp the grip to convey riding commands, sometimes gently, sometimes with great force, according to your temperament or to your mood, and the engine, producing a sound that is music to the ears of every rider that lives for the ride, responds to your input for performance and carries you into the wind.

Malossi grips have no competition when concerning your motorcycle ride: they are safe, anatomically comfortable, indestructible, and stylish too, because the care for aesthetics has never been of secondary importance to us!



Malossi GRIPS PAIR

Without side fastening

6914059.RO € 20,60

red



With side fastening

6914060.RO € 20,60

red



Without side fastening

6914059.YO € 20,60

yellow



With side fastening

6914060.YO € 20,60

yellow



Technical Characteristics :

- dual compound, dual hardness, dual colour;
- micro-pyramid pattern provides firm safe grip;
- chassis in semi-rigid torque-limited elastomer;
- top-quality material, special anti-allergy material;
- resistant to atmospheric agents, UV rays, ozone;
- anatomical shape and structure;
- two grooves for steel wire give extra security;
- length 125 mm, standard 22/24 mm diameter .

GRIPS PAIR with Malossi TRIBAL logo

Without side fastening

6914574.WO € 24,00

white



With side fastening

6914575.WO € 24,00

white



Without side fastening

6914574.BO € 24,00

black



With side fastening

6914575.BO € 24,00

black



Technical Characteristics :

- Top quality material
- Resistant to atmospheric conditions, UV rays, Ozone
- Inner flange reinforced for hand support and to eliminate vibrations
- UP is marked at the ends of the grip to designate the correct orientation upon installation
- Anatomically designed for comfort and strength

UNIVERS



MALOSSI

Malossi S.p.a. Via Roma, 118/I
40012 Calderara di Reno (Bologna) Italy
Tel. +39 051 6460011 - Fax +39 051 6460033
www.malossi.com